

SALSCO, INC.

LEADER BY DESIGN

OWNER'S MANUAL
PARTS MANUAL
SERVICE MANUAL



SALSCO, INC.
TURF EQUIPMENT DIVISION
105 SCHOOL HOUSE ROAD
CHESHIRE, CONN. 06410 USA

* NOTE: PLEASE READ "CAUTIONS" IN THIS MANUAL

4 - 1 - 91
0705001-A
0705000

STATEMENT OF FACT

YOU HAVE JUST PURCHASED THE HIGHEST QUALITY, MOST IDEAL CURBING MACHINE ON THE MARKET TODAY. THIS UNIT HAS THE ABILITY TO MEET EXACT STANDARDS AND PERFORM FOR YEARS WITH MINIMUM DOWN TIME. HOWEVER, IT CANNOT READ NOR WILL IT UNDERSTAND THIS MANUAL NO MATTER HOW LONG YOU LEAVE IT ON TOP OF THE MACHINE. IT IS YOUR RESPONSIBILITY TO READ AND UNDERSTAND IT. IT IS ALSO YOUR RESPONSIBILITY TO BE CERTAIN THIS INFORMATION IS PASSED ALONG TO ANYONE WHO IS EXPECTED TO OPERATE THIS EQUIPMENT. SHOULD YOU CHOOSE NOT TO READ, UNDERSTAND AND PASS ALONG THE INFORMATION PROVIDED YOU, PLEASE EXPECT EQUIPMENT FAILURE AND POSSIBLE INJURIES TO PERSONS AROUND THIS EQUIPMENT.

FOR THE SAFETY OF THE OPERATOR, IT IS IMPERATIVE THAT THIS MANUAL IS CAREFULLY READ AND UNDERSTOOD.

HAVING READ THIS MANUAL, IT IS YOUR RESPONSIBILITY TO BE SURE THAT ALL NEW OPERATORS READ AND UNDERSTAND THIS MANUAL ESPECIALLY THE CAUTIONS ON PAGE 7.

AS A MANUFACTURER OF EQUIPMENT WE HAVE A RESPONSIBILITY TO DESIGN A SAFE PIECE OF EQUIPMENT. HOWEVER, ONLY YOU CAN PREVENT ACCIDENTS!!

READ AND UNDERSTAND MANUAL BEFORE OPERATING

DESCRIPTION

E-Z HAND CURBER

Weighing only 112-lbs., the E-Z HAND CURBER, is easily transported from job to job. Simple to set up and operate, E-Z HAND CURBER installs straight and curved curbing, having a 36" turning radius. No pushing or pulling is required ... the machine is propelled by raising and pressing down on the pump handle. Because of its compact size (48" x 23"), E-Z HAND CURBER is able to work in tight areas larger machines cannot. Ideal for curbing driveways, parking lots, and around planted areas; as well as a host of patching jobs resulting from snow plow damage and road repair.

READ AND UNDERSTAND MANUAL BEFORE OPERATING

DESCRIPTION

E-Z POWERED CURBER

Weighing only 172 lbs., this compact little machine like the Hand Curber, is easily transported from job to job. It is also simple to set up and operate. Powered Curber installs straight and curved curbing. The machine is propelled by a 5 H.P. Briggs and Stratton engine which compacts material into the mold. Once the mold is filled the machine moves ahead. Because of its compact size (48" x 23"), Powered Curber can work in tight areas. Ideal for curbing driveways, parking lots, and around planted areas; as well as a host of patching jobs resulting from snow plow and general damage. Powered Curber is easy to operate using concrete or asphalt.

READ AND UNDERSTAND MANUAL BEFORE OPERATING

MANUFACTURED BY:

SALSCO, INC.
CONSTRUCTION DIVISION
105 SCHOOL HOUSE ROAD
CHESHIRE, CT 06410
(203) 271-1682
FAX: (203) 271-2596

THIS MANUAL COVERS MODELS: E-Z HAND CURBER 5001
E-Z POWERED CURBER 5002

This company reserves the right to discontinue, add improvements to, or change the design of any model or product at any time without obligation to improve existing machines, either by changing the design or adding new parts.

It has been and will continue to be the policy of SALSCO to update existing machines at its own discretion. Whenever possible, new designs will be made in such a way, that they can be "Retro Fit" if so desired.

Record in the space provided below the model and serial number of this unit. Please retain these numbers for future reference.

No parts orders will be accepted without model numbers or part numbers. All part numbers are listed in this manual.

SERIAL NUMBER

MODEL NUMBER & NAME

NOTE: Be sure to complete your warranty card. This will insure immediate processing of any warranty claims.

READ AND UNDERSTAND THIS MANUAL BEFORE STARTING MACHINE

OPERATING INSTRUCTIONS

E-Z HAND CURBER

E-Z POWERED CURBER

A. ASPHALT USE

1. Be sure to oil with diesel oil all parts of machine that will come in contact with asphalt.
2. On Powered unit be sure you've installed the black push arms for use on asphalt.
3. Adjust rear tires so mold is dragging on ground.
4. On Hand unit short strokes work best. Don't let slide open more than 2".
5. Put asphalt in either machine and fill mold. Let unit sit for a couple of minutes. This will warm machine.
6. Now it's a simple matter of adding asphalt to hopper as machine needs it. It is best not to fill hopper.

TIPS:

- * Short easy strokes will give a better compacted, longer lasting curb on Hand unit.
- * Oil well! This will make clean up a breeze.
- * When done clean and oil unit.

READ AND UNDERSTAND THIS MANUAL BEFORE STARTING MACHINE

OPERATING INSTRUCTIONS

FOR E-Z HAND CURBER

E-Z POWERED CURBER

B. CONCRETE USE

1. Oil unit with curb form oil. Oil all parts of unit that will come in contact with concrete.
2. HAND MACHINE. Short easy strokes work best.
3. POWERED UNIT. Be sure to use yellow arms.
4. Mixing of concrete is critical. It must be dry, a 0" to 2" slump is advisable. Adjust mixture as needed.
5. Do not fill hopper. Add mixture by the shovel full as needed.
6. If mixture used is at desired slump, when you're finished, the only work needed would be to broom finished curb.

TIPS:

- * If you need 24" or so of footing; first dig trench, pour concrete level to ground surface. Then cut a key into top of footing with a 2 X 4. After this dries, go in with the Powered Curber and lay your curb.
- * Be sure to clean machine well after each use.

SAFETY IS A PRIME CONCERN AT SALSCO AND THE SAFETY DECALS ON YOUR MACHINE ARE A HIGHLY VISIBLE AND CONSTANT REMINDER TO ALL OPERATORS. REPLACEMENT SAFETY DECALS MAY BE OBTAINED BY CALLING TOLL FREE 1-800-8SALSCO.

READ AND UNDERSTAND THIS MANUAL BEFORE STARTING MACHINE

MAINTENANCE AND SERVICE

- 1) Oil machine with diesel oil for asphalt application or with curb form oil for concrete, before and after using machine.
- 2) Follow manufacturer's specifications on engine maintenance and service.
- 3) Keep chains adjusted. Check weekly.

CAUTIONS

- 1) NEVER LEAVE MACHINE UNATTENDED WHILE MOTOR IS RUNNING.
- 2) NEVER PUT HANDS IN HOPPER.
- 3) NEVER REACH UNDER CHAIN GUARDS.

READ AND UNDERSTAND MANUAL BEFORE OPERATING

3/91

SALSCO, INC.

LEADER BY DESIGN

105 SCHOOL HOUSE ROAD
 CHESHIRE, CONNECTICUT 06410
 PHONE 203-271-1682
 FAX 203-271-2596
 1-800-8-SALSCO

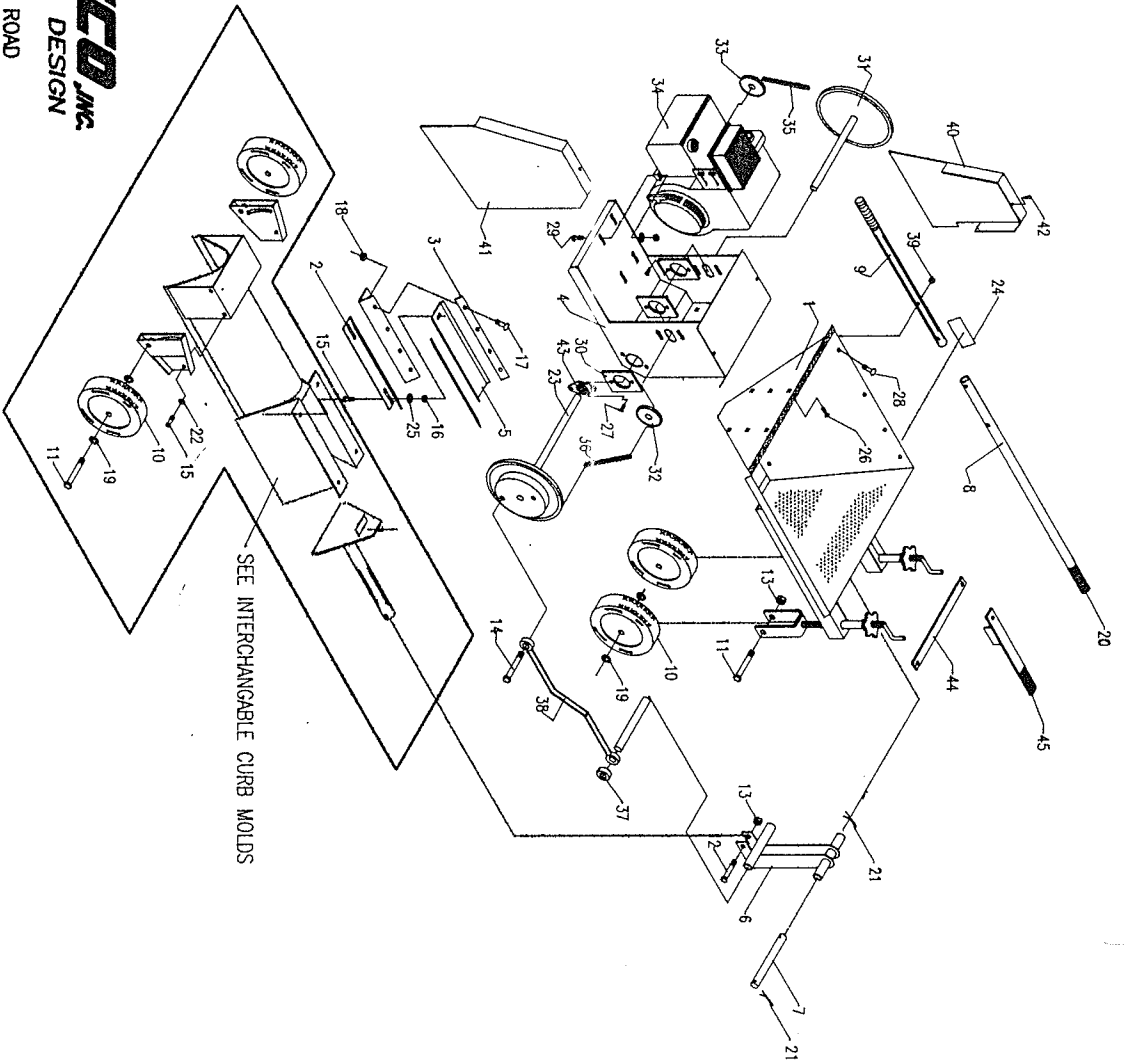

SEE INTERCHANGABLE CURB MOLDS

ITEM	PART NO.	PART DESCRIPTION	QTY
1	0226002	HOPPER	1
2	0506005	BRACKET	2
3	0541010	SPACER PLATE	2
4	026075	ENGINE BRACKET	1
5	0541011	HOPPER DOOR	1
6	0206076	HOPPER DOOR	1
7	0443002	PIVOT BRACKET	1
8	0423017	PIVOT BRKT MTING ROD	1
9	0423018	HANDLE FRONT	1
10	0354001	HANDLE BACK	1
11	0346412	WHEEL	2
12	0346408	HEX SCREW 1/2 X 3 1/2	2
13	0338104	HEX SCREW 1/2 X 2 1/2	2
14	0337011	LOCK NUT 1/2-13	3
15	0346203	7/16 HEX-GRSSE X 1 3/4	1
16	0338102	HEX SCREW 3/8 X 1	8
17	0346028	LOCK NUT 3/8-16	8
18	0338109	CARRIAGE BOLT 1/4 X 3/4	8
19	0353104	LOCK NUT 1/4-20	4
20	0332001	WASHER 1/2	4
21	0340003	HANDLE GRP	3
22	0353003	COILER PIN	2
23	0248016	LOCKWASHER	2
24	0314006	ARM DRIVE SHAFT	1
25	0355102	DECAL MODEL/SERIAL NO.	1
26	0346127	FLAT WASHER 3/8	4
27	0346126	CBOLT 5/16 X 3/4	6
28	0346131	CBOLT 5/16 X 1/2	8
29	0346103	HEX BOLT 5/16 X 1 1/2	4
30	0441305	SHAFT PLATE	4
31	0248017	SPINDLE ASM	1
32	0351002	3" SPINDLE	1
33	0351003	2 1/4" SPINDLE	1
34	0337011	5 HP BRGSS ENGINE	1
35	0309001	ENGINE CHAIN	1
36	0309002	ARM CHAIN	1
37	0311006	COLLAR	2
38	0433013	LEVER (ASPHALT) BLACK	2
39	0433014	LEVER (CONCRETE) YELLOW	2
40	0338101	LOCK NUT 5/16	22
41	0421014	RIGHT GUARD	1
42	0346003	LEFT GUARD	1
43	0303005	HEX BOLT 1/4 X 1/2	6
44	0406079	BEARING 3/4	4
45	0423019	STEERING BRACKET	4
		STEERING HANDLE	1

ASSEMBLY NO. 0005003 SUBASSEMBLY NO. 0226003 DWG NAME POWER CURBER CATALOG DWG NO. 0705003

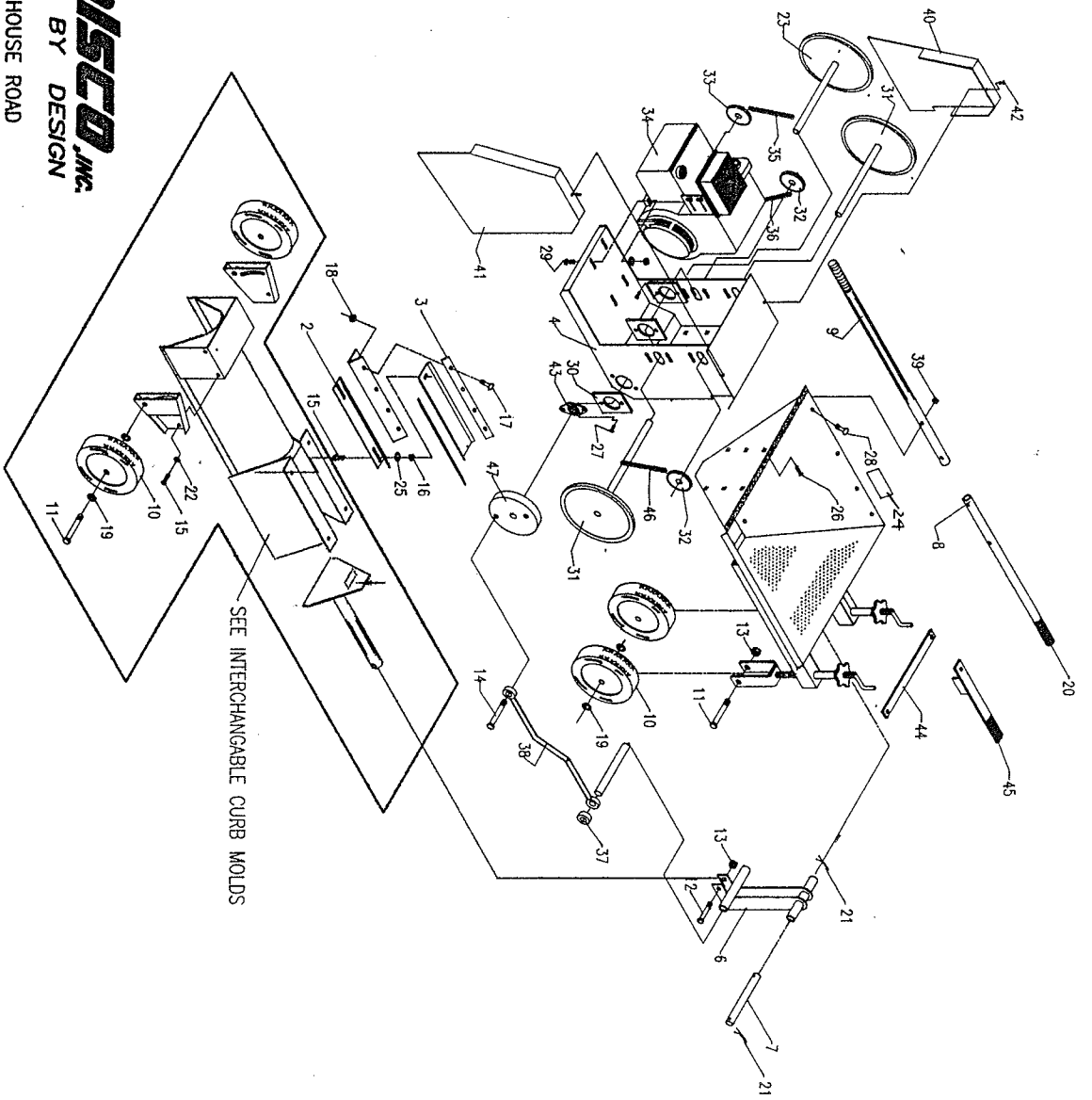

ITEM	PART NO.	PART DESCRIPTION	QTY
1	0226002	HOPPER	1
2	0506005	BRACKET	2
3	0541010	SPACER PLATE	2
4	0206074	ENGINE BRACKET	2
5	0541011	HOPPER DOOR	1
6	0206076	PIVOT BRACKET	1
7	0445002	PIVOT BRKT LIFTING ROD	1
8	0423017	HANDLE FRONT	1
9	0423018	HANDLE BACK	1
10	0354001	WHEEL	2
11	0346412	HEX SCREW 1/2 X 3 1/2	2
12	0346408	HEX SCREW 1/2 X 2 1/2	1
13	0338101	LOCK NUT 1/2-13	3
14	0337011	7/16 HEX-GRIBSE X 1 5/4	1
15	0346203	HEX SCREW 3/8 X 1	8
16	0338102	LOCK NUT 3/8-16	8
17	0346028	CARRIAGE BOLT 1/4 X 3/4	8
18	0336100	LOCK NUT 1/4-20	4
19	0353104	WASHER 1/2	4
20	0332001	HANDLE GRIP	3
21	0340003	COTTER PIN	2
22	0353003	LOCKWASHER	4
23	0248016	ARM DRIVE SHAFT	1
24	0314006	DECAL MODEL/SERIAL NO.	1
25	0353102	FLAT WASHER 3/8	4
26	0346122	C/BOLT 9/16 X 3/4	6
27	0346126	C/BOLT 5/16 X 1/2	12
28	0346131	C/BOLT 5/16 X 1 1/2	8
29	0346103	HEX BOLT 5/16 X 1 1/2	4
30	0441305	SHAFT PLATE	6
31	0248017	SPINDLE ASM	2
32	0351002	3" SPINDLE	2
33	0351003	2 1/4" SPINDLE	2
34	0337011	5 HP BRIGGS ENGINE	1
35	0309003	ENGINE CHAIN	1
36	0309005	ARM CHAIN	1
37	0311006	COLLAR	2
38	0433013	LEVER (ASPHALT) BLACK	2
39	0433014	LEVER (CONCRETE) YELLOW	2
40	0421016	LOCK NUT 5/16	26
41	0421017	RIGHT GUARD	1
42	0346003	LEFT GUARD	1
43	0303003	HEX BOLT 1/4 X 1/2	6
44	0406079	BEARING 3/6	6
45	0423019	STEERING BRACKET	1
46	0309004	STEERING HANDLE	1
47	0429003	SPROCKET CHAIN HUB	1

ASSEMBLY NO. 0005002 SUBASSEMBLY NO. 0226002 DWG NAME POWER CURBER CATALOG DWG NO. 0705002

SALSICO, INC.
LEADER BY DESIGN
 105 SCHOOL HOUSE ROAD
 CHESHIRE, CONNECTICUT 06410
 PHONE 203-271-1682
 FAX 203-271-2596
 1-800-8-SALSICO

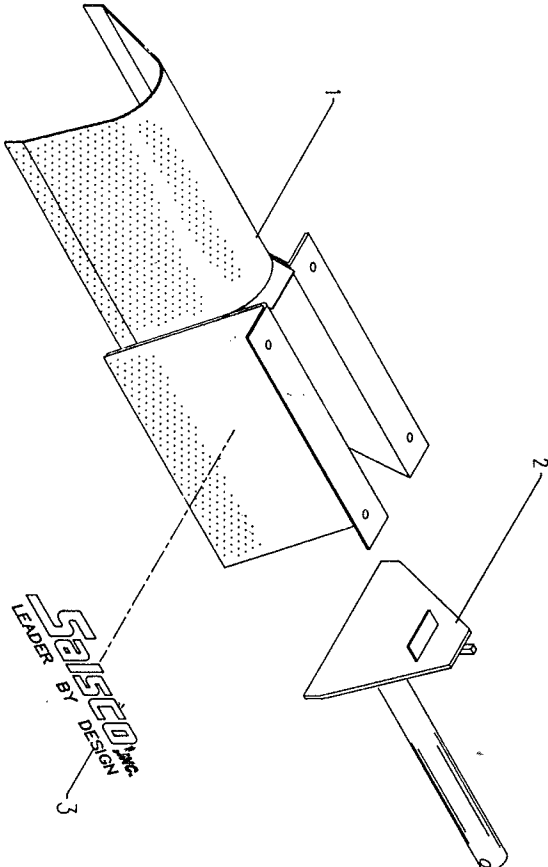
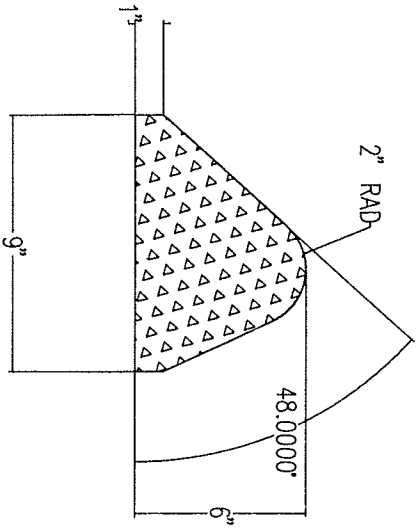

ITEM	PART NO.	PART DESCRIPTION	QTY
1	0228001	HOUSING	1
2	0241013	PUSH PLATE	1
3	0314012	DECAL	2
4	0236030	OPTIONAL TROWEL	1

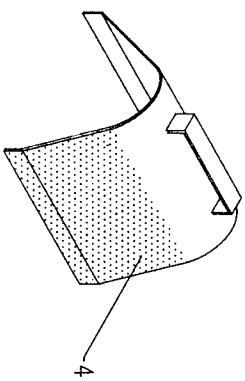

SALSCO, INC.
LEADER BY DESIGN

105 SCHOOL HOUSE ROAD
CHESHIRE, CONNECTICUT 06410
PHONE 203-271-1682
FAX 203-271-2596
1-800-8-SALSCO

ASSEMBLY NO. 0005001 SUBASSEMBLY NO. 0136020 DWG NAME OPTIONAL HOUSING/PUSH PLATE KIT CATALOG DWG NO. 0736020

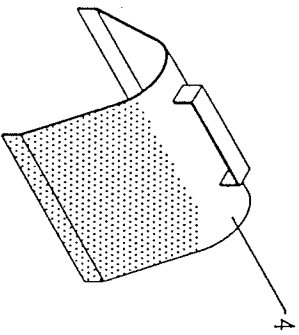
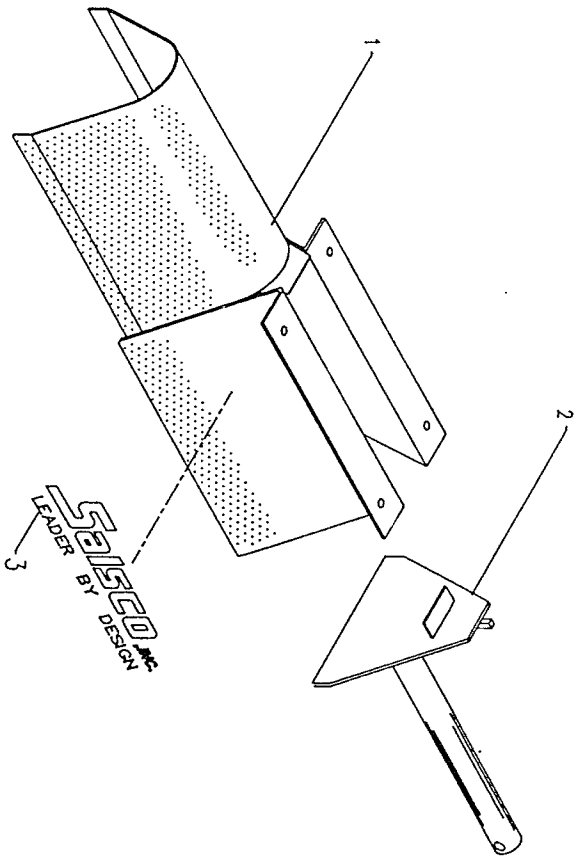
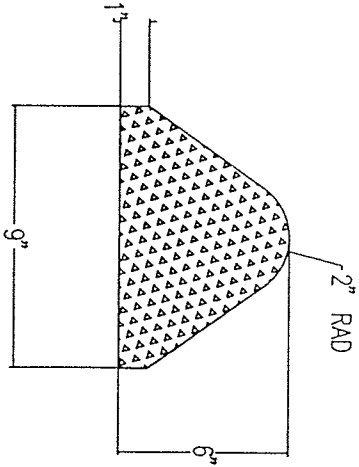

ITEM	PART NO.	PART DESCRIPTION	QTY
1	0228002	HOUSING	1
2	0241019	PUSH PLATE	1
3	0314012	DECAL	2
4	0238028	OPTIONAL TROWEL	1

Salsco INC.
LEADER BY DESIGN

105 SCHOOL HOUSE ROAD
CHESHIRE, CONNECTICUT 06410
PHONE 203-271-1682
FAX 203-271-2596
1-800-8-SALSCO

ASSEMBLY NO. 0005001 SUBASSEMBLY NO. 0136021 DWG NAME OPTIONAL HOUSING/PUSH PLATE KIT CATALOG DWG NO. 0736021

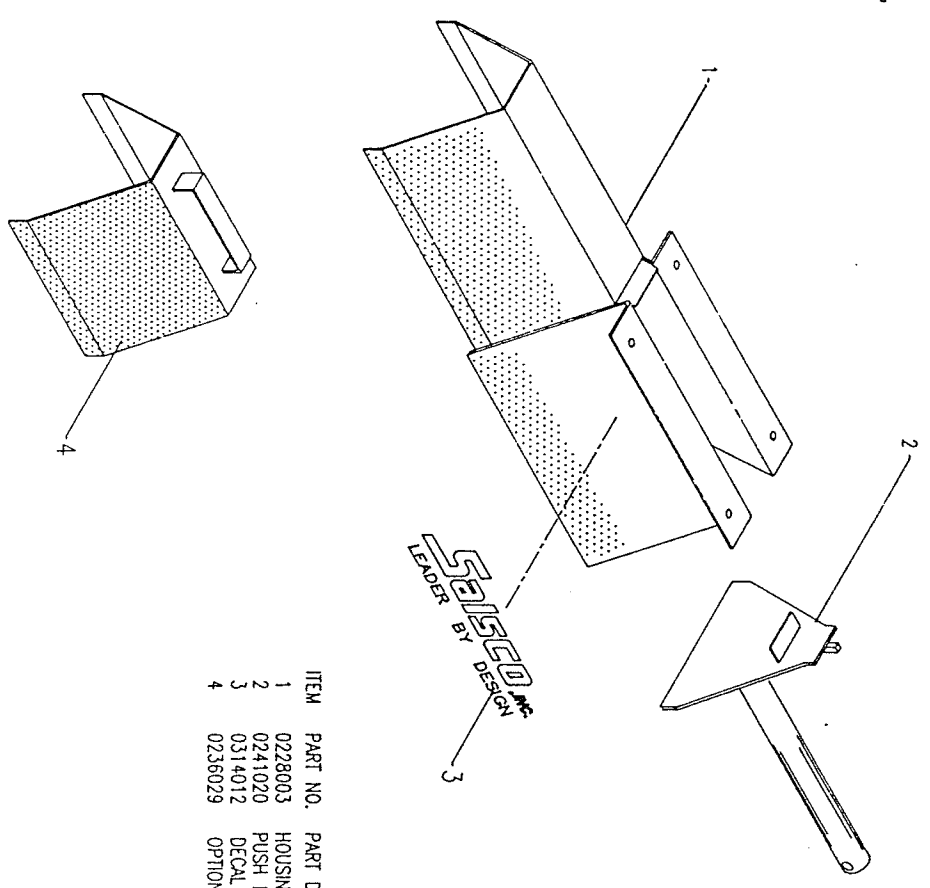
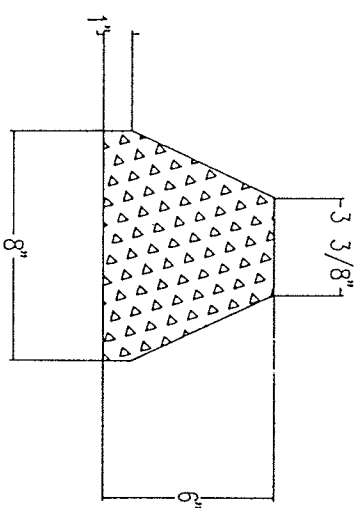

ITEM	PART NO.	PART DESCRIPTION	QTY
1	0228003	HOUSING	1
2	0241020	PUSH PLATE	1
3	0314012	DECAL	2
4	0236029	OPTIONAL TROWEL	1

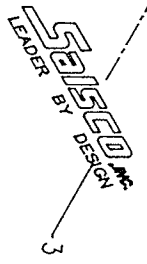

SALSICO, INC.
LEADER BY DESIGN

105 SCHOOL HOUSE ROAD
CHESHIRE, CONNECTICUT 06410
PHONE 203-271-1682
FAX 203-271-2596
1-800-8-SALSICO

ASSEMBLY NO. 0005001 SUBASSEMBLY NO. 0136022 DWG NAME OPTIONAL HOUSING/PUSH PLATE KIT CATALOG DWG NO. 0736022

- 1) REMOVE THE FOLLOWING ITEMS FROM THE BASE OF THE HOPPER
- 2) TAKE ITEM (5) SPACER HOUSING AND BOLT TO THE BASE OF THE HOPPER
- 3) TAKE ALL ITEMS FROM STEP 1) AND INSTALL TO THE BASE OF ITEM (5) SPACER HOUSING.

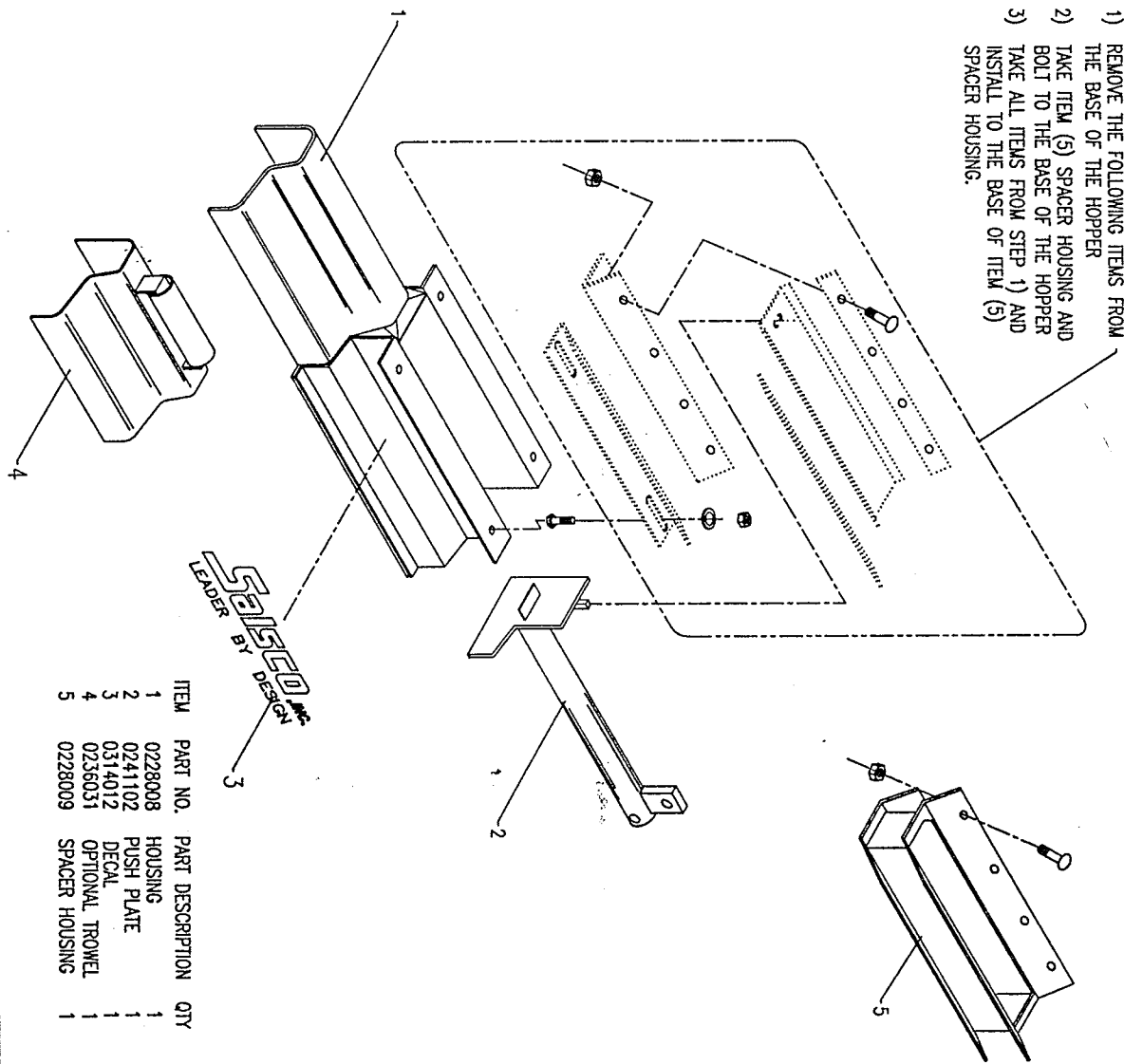
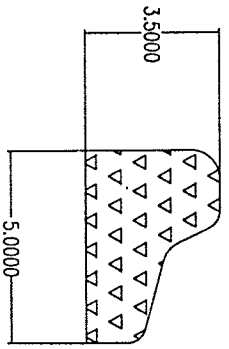

ITEM	PART NO.	PART DESCRIPTION	QTY
1	0228008	HOUSING	1
2	0241102	PUSH PLATE	1
3	0314012	DECAL	1
4	0236031	OPTIONAL TROWEL	1
5	0228009	SPACER HOUSING	1

SAISCO INC.
 LEADER BY DESIGN
 105 SCHOOL HOUSE ROAD
 CHESHIRE, CONNECTICUT 06410
 PHONE 203-271-1682
 FAX 203-271-2596
 1-800-8-SALSCO

ASSEMBLY NO. 0005001 SUBASSEMBLY NO. 0136034 DWG NAME OPTIONAL HOUSING/PUSH PLATE KIT CATALOG DWG NO. 0738034

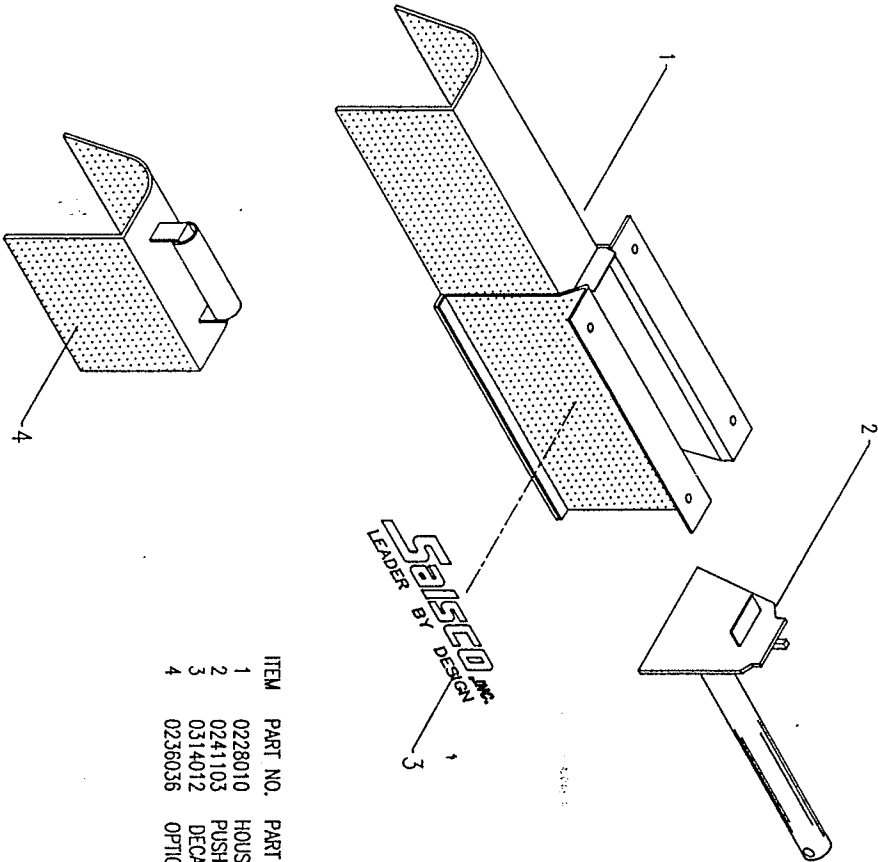
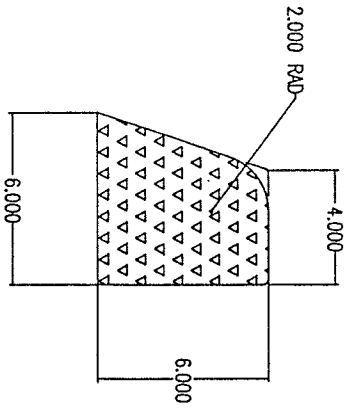

ITEM	PART NO.	PART DESCRIPTION	QTY
1	0228010	HOUSING	1
2	0241103	PUSH PLATE	1
3	0314012	DECAL	1
4	0236036	OPTIONAL TROWEL	1

Saisco, Inc.
LEADER BY DESIGN

105 SCHOOL HOUSE ROAD
CHESHIRE, CONNECTICUT 06410
PHONE 203-271-1682
FAX 203-271-2596
1-800-8-SALSCO

ASSEMBLY NO. 0005001

SUBASSEMBLY NO. 0136035

DWG NAME OPTIONAL HOUSING/PUSH PLATE KIT

CATALOG DWG NO. 0736035

Salsco, INC.

LEADER BY DESIGN

105 SCHOOL HOUSE ROAD • CHESHIRE • CONNECTICUT 06410
FAX (203) 271-2596 • 1-800-8-SALSCO • (203) 271-1682

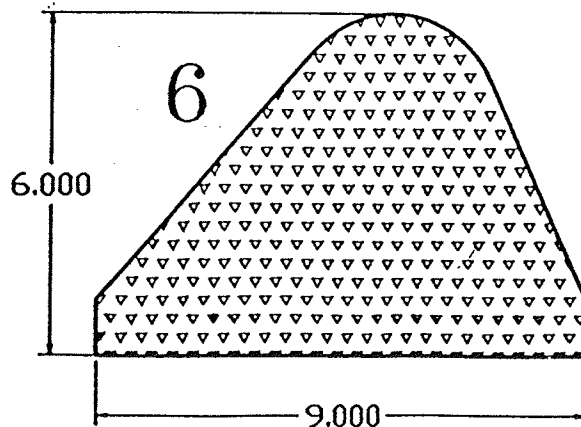
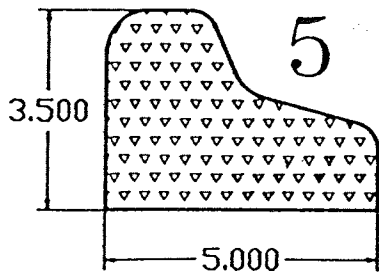
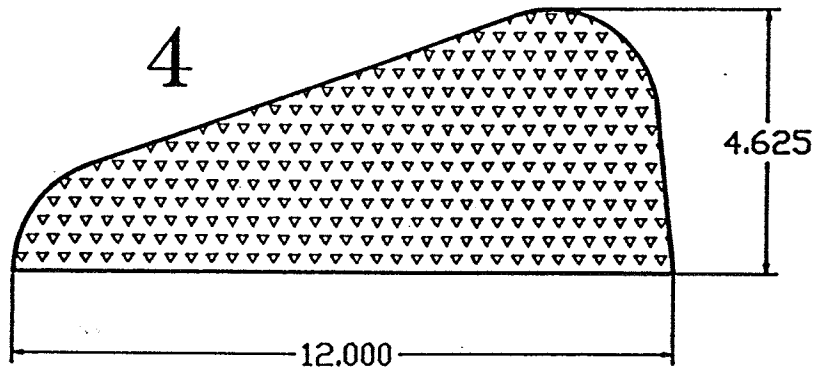
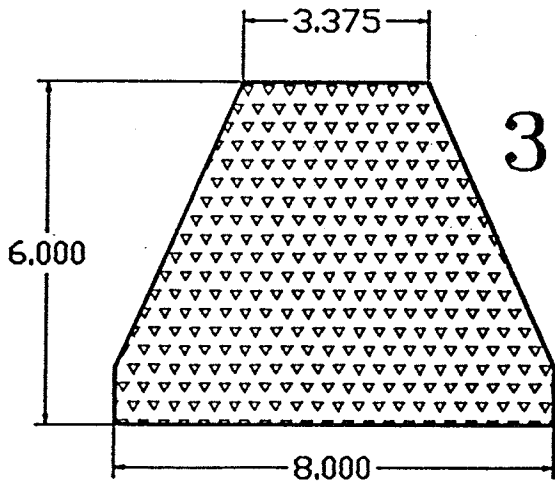
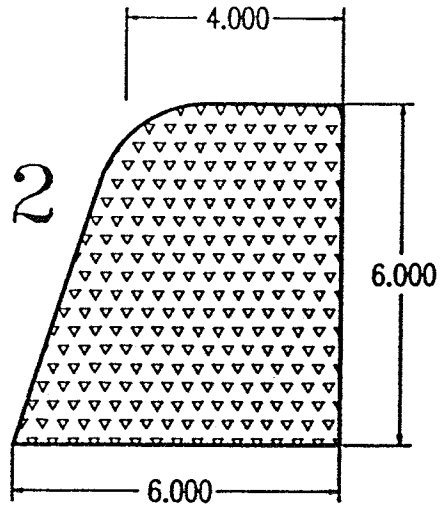
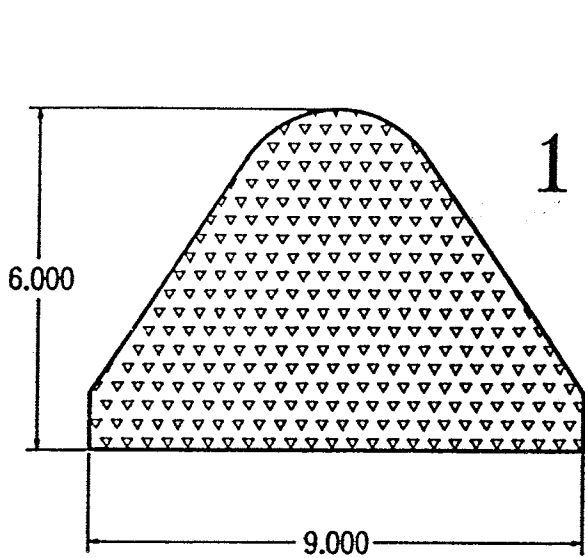

WARRANTY POLICY

Your Salsco Commercial or Turf Equipment product is a commercial type product and is normally manufactured and sold for commercial or industrial use. Salsco will, for the original purchaser, for one (1) year from the date of purchase (90 days if used for rental purposes) repair, replace, free of charge, any part or parts found to be defective in material, workmanship or both. Any transportation charges to be borne by the purchaser.

If, during the Warranty Period, the product does not function properly due to defect, simply contact Salsco and follow the warranty procedures on page 12.

SALSCO, INC.
105 School House Road
Cheshire, CT 06410
(203) 271-1682
Fax: (203) 271-2596
1-800-8SALSCO

This warranty does not include incidental or consequential damages and is exclusive of any implied warranties.

This warranty does not include normal maintenance parts, including, but not limited to tires, molds, etc.

This warranty does not include parts or components which are covered under the original manufacturers warranty, including, but not limited to tires.

READ AND UNDERSTAND THIS MANUAL BEFORE OPERATING

SALSCO'S WARRANTY PROCEDURE

In order for Salsco to process your warranty claims (see copy on page-13) in a timely manner you must follow the simple procedures listed below:

1) MACHINE OR PART FAILURE

- a) Call our service department for easy instruction on how to correct or repair the problem. Preventive maintenance will also be suggested.
- b) Fill in all information requested on warranty claim form (date of purchase, company name, address, etc.).
- c) List all parts used. Make sure part numbers are correct. You can obtain these from your manual. Any parts that you believe to be defective or any parts that break should be retained for possible inspection until after the warranty has been paid or part has been replaced.

Please make note that Salsco is not responsible for the warranty or failure of engines or hydraulic pumps. Please call the manufacturer directly.

If you have any questions, please do not hesitate to call us. Our toll free number is 1-800-8SALSCO.

READ AND UNDERSTAND THIS MANUAL BEFORE OPERATING

