

Quality of Workmanship
Innovative Design
Built to Last!

Salsco, INC.
LEADER BY DESIGN



**MADE IN
THE U.S.A.**

Model HP2E Electric Roller Operators and Parts Manual



MANUFACTURER OF OUTDOOR POWER EQUIPMENT

Products for Turf & Lawn care, Rental, Construction, Tree Care, Wood Processing, Nursery & Farm Industries

3-1/2" - 18" Capacity, Gas, Diesel, & PTO Wood/Brush Chippers - Slab Chippers
Gas, Electric & Tow Behind Rollers - Tranz-Former Roller - CRV Core Recovery Vehicle
Mini-Paver - Mini-Track Paver - Cobra Curbers - Scorpion Router - Concrete Paver
Chipper Shredder Vacuums - Tailgate & Truck loader Vacuums

Salsco, INC.
LEADER BY DESIGN

9 cu. yds. - 50 cu. yds. Per Hour, Electric, PTO & Diesel-
Powered Shaving Mills 105 Schoolhouse Road Cheshire, CT
06410 U.S.A. 800-872-5726 (Toll Free), 203-271-1682, 203-271-2596
(Fax) www.salsco.com, sales@salsco.com

TABLE OF CONTENTS

MODEL HP2E ELECTRIC ROLLER - 0009118

COVER & TABLE OF CONTENTS.....	Pages 1 – 2
STATEMENT OF FACT	Page 3
SPECIFICATIONS & FEATURES	Page 4
SAFETY & OPERATING INSTRUCTIONS	Pages 6-12
-BATTERY CHARGING	
SCREEN MONITOR DISPLAY.....	Page 13
BATTERY CHARGING PROCEDURE.....	Pages 14-16
BATTERY CHARGING DISPLAY.....	Page 17
FAULT CODES.....	Pages 18-23
HOW TO CHANGE BETWEEN TRAINING AND PRO MODES.....	Page 24
PARTS DIAGRAMS	Pages 25 – 52

SALSCO, INC.

105 Schoolhouse Road
Cheshire, CT 06410 USA
800-872-5726, 203-271-1682
203-271-2596 (Fax)

STATEMENT OF FACT

You have just purchased the highest quality, most dependable Electric Roller on the market today. This unit meets exact standards and performs for years with minimum downtime. **HOWEVER**, it cannot read, nor will it understand this manual no matter how long you leave it on top of the machine.

It is your responsibility to read and understand this manual; it is also your responsibility to be certain this information is passed along to anyone who is expected to operate this equipment. Should you choose not to read, understand, and pass along the information provided to you, please expect equipment failure and possible injuries to people around this equipment.

For the safety of the operator, it is imperative that this manual is carefully read and understood.

Once you have read this manual, it is your responsibility to be sure that all new operators read and understand this manual, especially all cautions stated.

As a manufacturer of equipment, we have a responsibility to design a safe piece of equipment. **NOTE:** The important safeguards and instructions in this manual are not meant to cover all possible conditions and situations that may occur. It must be understood that common sense, caution, and care are factors which cannot be built into any product. These factors must be supplied by the person(s) caring for and operating this equipment.

**ROLLER MUST BE CHARGED UPON RECEIPT,
PRIOR TO DELIVERING TO CUSTOMER.**

**BATTERY WILL BE CHARGED APPROXIMATELY
40-50% AT THE FACTORY.**

**BATTERY MUST BE CHARGED USING ONLY THE
FACTORY SUPPLIED POWER CORD ON A
DEDICATED 20 AMP SERVICE.**

**BATTERY MUST BE CHARGED AT LEAST EVERY
3 MONTHS WHEN IN STORAGE.
ONLY YOU CAN PREVENT ACCIDENTS!**

READ AND UNDERSTAND THIS MANUAL BEFORE STARTING THE MACHINE

1. WARRANTY:	Read warranty policy for details.
2. BATTERY:	One (1) 48V/200AH Lithium Battery in steel case for safety.
3. MOTORS:	Two (2) 2 Drive motors. One (1) Steering motor.
4. CONTROLLER:	Four (4) Controllers. Three (3) Drive. One (1) Steering.
5. SMART SCREEN PANEL:	Standard See page 11
6. PEDAL ADJUSTMENT:	Manual Pedal Height Adjustment
7. LED LIGHT KIT:	Standard
8. CROSS CONTAMINATION PREVENTION KIT:	Standard
9. SEAT:	Arm rest seat with forward/reverse slide adjustment. Standard
10. STEERING SYSTEM:	All two (2) roll housings articulate and oscillate at different degrees, which allows travel without bruising. When steering the controllers change RPM at the rolls which eliminate any damage to the turf while turning.
11. STEERING WHEEL:	14" diameter, automotive type. Tactile Feedback Device (TFD®) steering unit delivers high-fidelity tactile feedback and maximum control to the operator.
12. MAIN FRAME:	2-1/2" x 2-1/2" x 1/8" square steel tube. Fully gusseted with continuous welds.
13. DRIVE ROLLS:	Two (2) oscillating steel rolls, driven for positive traction. Two (2) - 10-3/4" diameter x 36" long. All rolls machined to within two thousandths of an inch concentricity.
14. TRACTION DRIVE:	Traction drive is accomplished by having all three rolls drive and float independently which allows for 100% roll to ground contact.
15. CLIMBING TRACTION:	Up to 40°
16. BRAKES:	Regenerative braking with parking brake included.
17. ROLLING SWATH:	36"
18. SPEED:	Variable, 0 - 7 MPH. Travel speed can set for new operators.
19. GROUND PRESSURE:	4.2 P.S.I. without water, 5.6 P.S.I. with water added to the rolls.
20. TILT TRANSPORT TRAILER:	Full 1/4" thick traction mat on both the trailer box and ramp. Magnetic locking system with safety hitch. Axle: Spindle type, with hub assemblies. Tire/Wheel assemblies: Two (2) 18.5 x 8.5-8, 6 ply. Hitch: Reversible and height adjustable. No ramps easy on easy off. Save time and your back.
21. GUARDS/DECALS:	All moving parts guarded. Full set of safety decals.
22. PAINT:	Roller: Orange, Trailer: Black. Polyester powder coat paint provides excellent outdoor weatherability and offers protection against ultraviolet discoloration. All parts painted separately.
23. ROLLER OPTIONS:	Top Dressing Brush Kit.
24. ROLLER DIMENSIONS:	Length: 56" Width: 70" Height: 60" Weight: 1360 lbs. (Approximately)
25. TRAILER DIMENSIONS:	Length: 132" Width: 68" Height: 50" Weight: 720 lbs.

SAFETY INSTRUCTIONS

1. This is a Roller not an ATV stay off steep inclines.
2. **NEVER** park on a green for any reason.
3. **NEVER** travel hills sideways. **ALWAYS** approach hills straight on.

OPERATING INSTRUCTIONS

START WITH CHARGING THE HP2E

Pick a dedicated charging area for this machine. Note: The HP2E should only be charged using the Salsco supplied charging cord. Do not use other extension cords. The unit should only be plugged into a dedicated 20-amp circuit. Note: If the building has an EMS (Energy Management System) charging may be interrupted.

Press the battery button In and quickly release. Be sure the button stays pushed in. Turn the key to the off position.

Plug the Salsco power cord into the HP2E.

Look into the window on the side of the battery charger. (See page 16)

-Blue light indicates the charger is working.

-Green pulsing light indicates unit is charging. The speed of pulsing light slows down as the battery becomes more charged. Light remains solid when the battery is fully charged.

-Flashing Yellow Triangle light indicates there is a problem with charging. If there is a charger failure. You will see a fault code on the digital display. See fault code sheet (pages 17-20) to see what the problem is. Identify and clear the code.

BE SURE THE MACHINE IS FULLY CHARGED BEFORE USING

1. Before you start, walk around the machine, and look for any damage or loose bolts or anything that might have happened to the machine.
2. Be sure to unplug the Salsco supplied wall cord. Roll it up, put it in a safe place. This is the only cord that should be used to charge this machine.
3. Be sure the trailer magnet is on, and the safety latch is in place.
4. First time operators should tow the machine to a practice green.
5. Loading and unloading the machine is much easier on flat level ground. This is not a must however it does make the task much easier.

Note: Holding machine on incline

- You cannot sit on an incline by holding the pedal and not moving. This will cause the controller to time out and go to neutral. This is a control feature to protect the electric motors.

Tilt trailer adjustment

ADJUSTING THE CUSHION VALVE

- With the machine on the trailer and the MAG on and the safety plate is flipped over the holding bolt so the machine is locked on the trailer.
- Rotate the cushion valve clockwise to close it finger tight.
- Then rotate counterclockwise 5 turns
- This is only a starting position
- Operator mount on the roller
- Turn the key on, keep your feet off the pedals
- Have a second person
 - Flip the safety plate up
 - Release the MAG
- Now press the pedal easy so the roller will begin to move off the trailer slowly.
- The cushion valve will control the speed which the trailer will tilt.
- Drive the roller off the trailer.
- The trailer should stay in the tilted position
- Now drive the roller on the trailer
- The trailer should not slam, the second person can adjust the cushion valve
- Turning the valve counterclockwise will allow the trailer to tilt faster , turning the cushion valve clockwise will slow the tilting.
- Once the valve is set you "**MUST**" tighten the set screw on the cushion valve.
- Keep in mind changing the weight of the operator may cause the need to readjust the cushion.

6. Before getting on the roller flip the safety latch and release the magnet by pressing the button at the end of the handle. Pivoting the handle will release the magnet.
7. Climb on the roller. Keep your feet off the pedals and turn the key to the ON position. Once the screen lights up you have power. You can now adjust the height of the pedals using the toggle switch on the dash to raise/lower the pedal platform. *The seat can also be adjusted by releasing the lever under the front of the seat.
8. Be sure the parking brake is released.
9. You are now ready to roll.
10. Keep in mind the pedals are to be operated by placing your feet in such a way that your toe (the front of your shoe) will control how you activate the pedal.

Only one pedal should be depressed at a time.

Note: The further you push the pedal, the faster the machine will travel.

Note: Be sure not to put your feet under the pedal platform when adjusting the pedals.

11. Touch the pedal on the side of the direction that you want to travel very easily, and the machine will begin to move.
12. As you drive off the trailer it will tilt and allow you to drive off.
13. You can now roll the green.
Note: When rolling to the left steer with your right hand. When rolling to the right use your left hand. This tip will make it much easier for you to operate the machine.
14. Familiarize yourself with the coast braking of the machine. When you remove your foot from the pedal the machine will slow down and stop. This takes a distance before you can change direction. The machine is designed to prevent the possibility of slipping, avoiding burning out on the turf.

Note: The hand brake is for parking only. It's not an emergency brake.

Another tip is to approach inclines straight on. When traveling hills, go straight up or down. Keep in mind this is a roller not an all-terrain vehicle.

15. Once you have become familiar with the operation of the roller it is time to load it back on the trailer. Maneuver the roller so the single roll will go onto the trailer first. Give yourself room when approaching the trailer. On the single roll there is a chrome nut on the roll housing. Line the chrome nut up with the

- yellow strip on the trailer and drive the roller onto the trailer. As you travel up the ramp the trailer will tilt into a horizontal traveling position. Secure the parking brake lever and turn the machine off with the key.
16. Climb off the roller. Pivot the magnet lever up, depress the button in the handle and raise full lock position. You will see the magnet attach itself to the roller. Flip the safety latch over the pin. You are now ready to travel to the next green.
 17. When you are finished for the day clean the machine before putting it away. Lightly wash or blow the debris off. **Do not use a high-pressure washer.**
 18. You can leave the battery on. It does not need to be turned off until the machine is being put into storage.

Note: Battery must be charged when battery gauge shows a 25% charge.

Note: When in storage the battery must be charged every 2-3 months.

Note: Supplemental section addressing Telematics will be sent soon.

SERVICE SECTION

1. **Grease bearings once a week. Be sure to wipe off excessive grease.**
2. **Check drive chains. You should have 1/4" of slack.**
3. **Make sure that the machine is clean.**
4. **Make sure that all bolts have not become loose.**
5. **Use air or lightweight water pressure to clean rolls off.**

Do Not use high-pressure water.

SERVICE SECTION

PLEASE SAVE THIS INFORMATION FOR LATER BATTERY MANAGEMENT AND CHARGING SYSTEM 48V LITHIUM

Attached is the process for extracting charger history & uploading new charging algorithms, as needed, into Delta-Q IC Series 650, 900 and 1200 Series. Below is the link to a YouTube video for clarification.

<https://www.youtube.com/watch?v=xLTmwAY6K6g>

Here is the downloadable Delta-Q "Simple IDAT software" hyperlink. This allows the ability to receive history and identify faults and codes to the battery and charging system along with additional information:

<https://support.delta-q.com/hc/en-us/articles/360015883272-Download-Simple-IC-Data-Analysis-Tool-v2-0>

Please familiarize yourself with the information in the links provided as it pertains to the battery management and charging systems used on Salsco Electric Rollers. Our customers are counting on Salsco and our Dealers to resolve failures in the field, it is important to be prepared and informed on how to navigate concerns that may arise. We are here to support you with the tools needed to gain knowledge on these systems and assist with troubleshooting. Please ASK QUESTIONS!

Important Notes on USB Drives to Ensure Successful Algorithm Upload:

- The USB Drive needs to be formatted as FAT32 filesystem in order to work. Please note that "exFAT" filesystem is not compatible with the charger USB Host Port. (USB sticks that are 32GB and larger will be formatted as exFAT on Windows by default. You can format 32GB and larger USB drives as FAT32 through Windows Commands.
- It's preferable to use brand name USB drives. They are built to industry standards which should prevent any issues while programming.

FIELD DIAGNOSTICS:

Items needed:

- USB thumb Drive (Read Delta-Q requirements for the Thumb Drive)
- Email address- must be readily accessible, that can send the extracted file from the charger and submit to Salsco Representative for review. (The information provides additional details.)
- Safety awareness! **DANGER** - Electrical Hazard- Do NOT touch Terminals with metal! **USE INSULATED TOOLS ONLY!**

What Tech Must Accomplish:

1. Identify the failure the customer is experiencing.
2. Identify voltage via the display with the charger disconnected - record measured voltage and Battery Life remaining.
3. Reset the battery by pressing the on/off button on the side of the battery. An audible click from the relay will indicate successful reset. Identify the battery voltage at terminals and record. (Note: switch access through hole in battery enclosure.)
4. Continue on the Delta-Q IC Series 900/1200 charger and follow the Delta-Q process for data extraction.
 - a. Use the first link provided (YouTube video) and the attached "IC Series Charge Tracking Download" for how to properly extract data.
5. Plug the charger in and wait until **all lights are on** and **identify if the charger is charging**, allow battery to charge for 5 minutes.
 - a. Use multimeter after 5 minutes of "On-charge" and identify the battery voltage while on charge - record it.
6. Identify if an "Energy Management System" is present and being utilized at the facility.
 - a. Identify the hours in which the E.M.S. is active and the hours the unit is being charged.
 - b. Be sure to charge outside of the E.M.S.
7. Submit all of your findings to a Salsco Representative.





***** BATTERY SHOULD BE CHARGED AFTER EACH USE OR WHEN 20% REMAINING , WHICHEVER OCCURS FIRST! *****

***** BATTERY MUST BE CHARGED USING THE SALSCO PROVIDED AC CORD ON A DEDICATED 20 AMP CIRCUIT *****



IC SERIES CHARGE TRACKING DOWNLOAD

HOW TO:

COLLECT INFORMATION FROM THE CHARGER

-  **STEP 1**
Prepare a USB data drive
-  **STEP 2**
Ensure the USB does not contain any previous files from Delta-Q Technologies or your OEM. These must be deleted off the USB before downloading information from the charger.
-  **STEP 3**
 - a. **OFFBOARD CHARGER**
If possible, unplug the DC connections first. Insert the AC cord to power up the charger and wait for start-up sequence to complete and only the blue LED light is lit.
 - b. **ONBOARD CHARGER**
With DC connection only, press the wrench button to verify charger is on.
-  **STEP 4**
Insert the blank USB drive into the charger.
-  **STEP 5**
The triangle USB indicator LED light will flash green to let you know the charger is working.



-  **STEP 6**
Once the USB indicator LED stops flashing and remains a solid green, the download is complete and the USB can be removed. This may take up to 2 minutes to complete.
-  **STEP 7**
If the DC connection were removed, the cables can now be reconnected and the process is complete.

HOW TO:

READ THE CHARGER DATA

To read the data, you will require the Simple IDAT software. The software can be [downloaded from our website on the Software and Accessories page](#). Run the installer and follow the instructions on the screen. Instructions to load the data onto the program are as follows:



-  **STEP 1**
Open the Simple IDAT software from your desktop.



-  **STEP 2**
Insert the USB drive into your laptop.

-  **STEP 3**
In the upper left corner of the window, press the "IMPORT USB DATA" button.



-  **STEP 4**
Select the USB drive you inserted and the program will download all the charger data by its serial number recorded on the drive. The information will automatically populate into the Simple IDAT table.
-  **STEP 5**
Additional information on the table can be found in the Simple IDAT user guide, which can be downloaded from Delta-Q's website

For more information, visit the resources page on www.delta-q.com.

IC SERIES SOFTWARE AND ALGORITHMS UPDATE

HOW TO:

UPDATE THE SOFTWARE OR LOAD AN ALGORITHM ON AN IC SERIES CHARGER

STEP 1
Obtain a CHARGER zip file from your OEM support team or distributor.

STEP 2
Right click and extract the CHARGER.zip file

STEP 3
Drag the 'CHARGER' folder from the .zip directly onto the USB drive.

STEP 4
Check that the USB drive has the following folders:

- a. <drive letter>:/CHARGER
- b. It should contain the subfolders
<drive letter>:/CHARGER/FILES
<drive letter>:/CHARGER/FILTERS

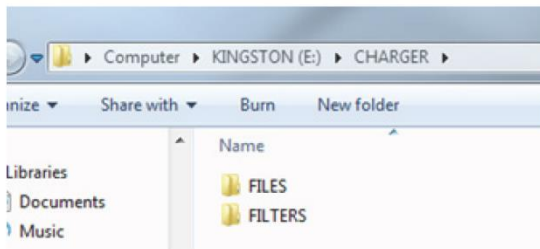

STEP 5
Apply AC power to the charger (ideally with the DC power connections removed) and wait for start-up sequence to complete and only the blue LED is lit.

NOTE: If DC power cannot be removed, the charger will start a charge cycle once the AC power is applied. Ensure usual safety procedures for charging are followed. The update process can still be followed but a full AC/DC power cycle may be required for it to fully take effect.

STEP 6
Insert the USB drive containing the software update from Delta-Q Technologies.



STEP 6
The USB drive will automatically download the update on its own. This is noted by the flashing green triangle and the display cycling 'U-S-b'.



NOTE:

Midway through the update, the charger may completely reset. This is not a cause for alarm. All LEDs will go out and the flashing green triangle light will begin approximately 5-7 seconds after the reset.

STEP 7
Once the green triangle LED is solid, the update is complete and the USB drive can be removed. This could take up to 5 minutes.

STEP 8
Confirm the default profile is set to the desired profile by pressing the wrench button. The display will indicate a ``P`` followed by a three-digit number.

- a. For example: P-0-1-1 for algorithm #11.

Salsco

HP3E Screen Monitor Display



**Note when the Brake is engaged
Screen will display message
Operator Not Present**

BATTERY CHARGING PROCEDURE

Power Cord Port



#1 Plug Power Cord into Port

Only use the Salsco provided Power Cord

Plug machine into a dedicated 20 amp circuit

#2 Turn Battery On

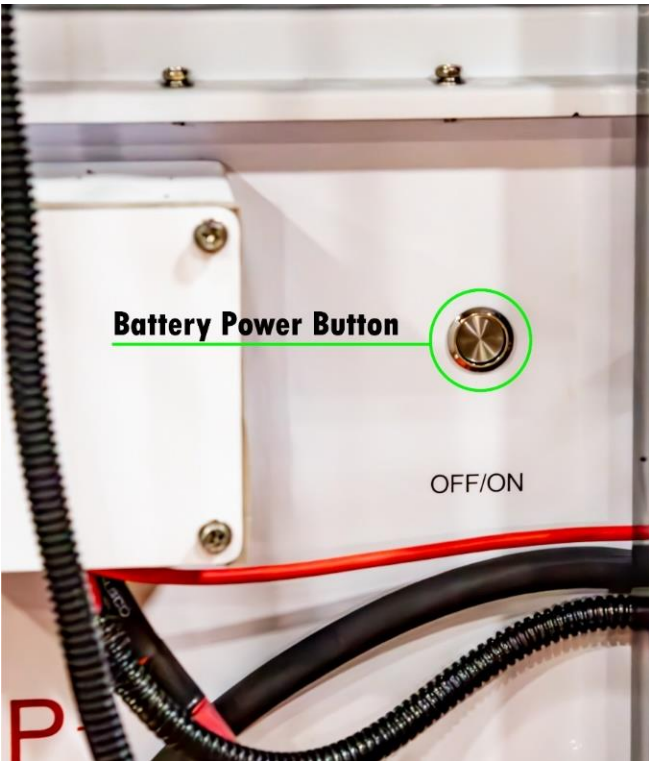
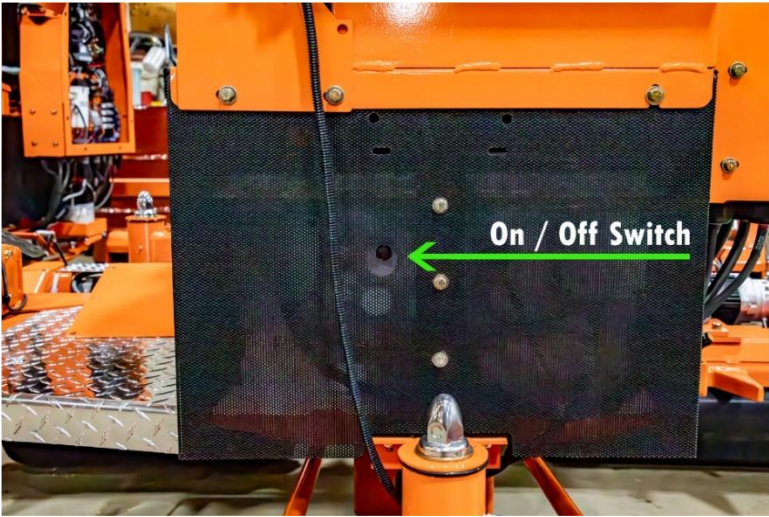
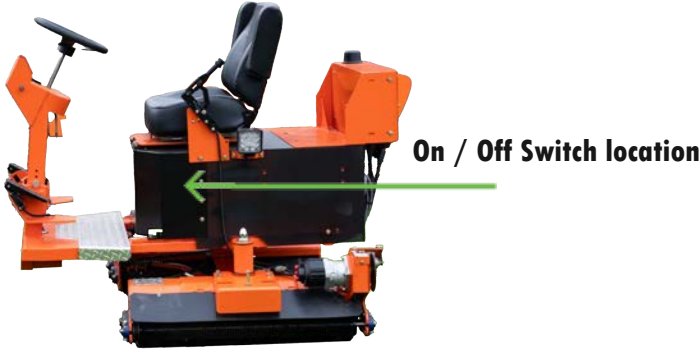

#3 Turn Key Off



Battery Charger



Yellow Lightning Bolt indicates the battery is going to start charging.

Digital Number Displays Error Code. See pages 15-18 for Fault Code meaning.

Flashing Yellow Arrow indicates there is a problem with charging.

Blue light comes on when cord is plugged in.

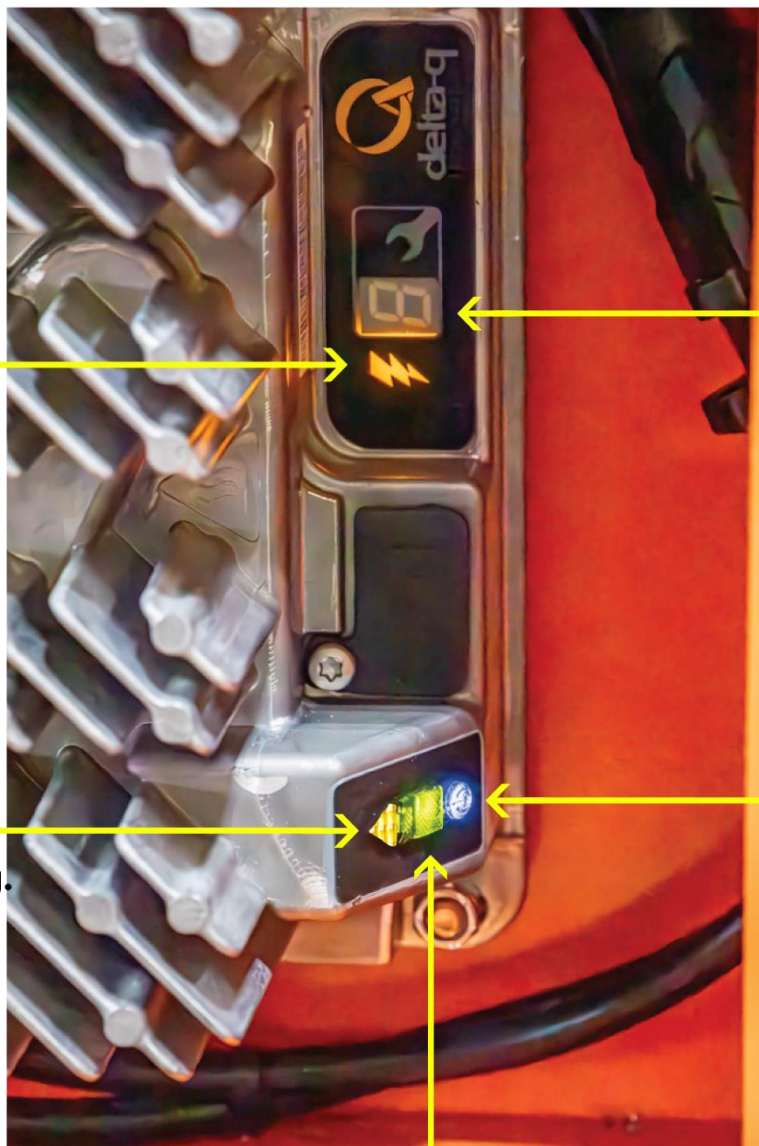

Green light pulses when charging. Pulsing speeds up as the battery charges. Light stays on when fully charged.

This document lists fault (F____) and error (E____) codes on these chargers. Most of these will be reported over CAN and logged. Not all will be displayed on chargers with a user interface. If a unit is not functioning and nothing is indicated or logged, check and cycle both AC and DC. If this condition persists, replace the charger.

Type	Code	Description	Troubleshooting and/or Recommended Actions
Alarm	E001	High Battery Voltage Error	Battery Voltage is too high to start charge. Check the battery voltage and cable connections. Check battery size and condition. This error will automatically clear once the condition has been corrected.
Alarm	E002	Low Battery Voltage Error	Battery Voltage is too low to start charge. Check the battery voltage and cable connections. Check battery size and condition. This error will automatically clear once the condition has been corrected.
Alarm	E003	Charge Timeout	Charge Timeout caused by battery pack not reaching required voltage within safe time limit. <u>Possible causes:</u> Charger output reduced due to high temperatures or low AC voltage. Poor battery health. Very deeply discharged battery. Poorly connected battery. Extra loads. Battery too large for algorithm selected. <u>Possible solutions:</u> Improve cooling air flow. Check for low AC voltage. Replace battery pack. Check DC connections. This error will automatically clear once the charger is reset by cycling DC.
Alarm	E004	Battery Defective	Battery could not be trickle charged up to the minimum voltage. Check for shorted or damaged cells. Check battery pack voltage matches charger voltage. Replace battery pack. Check DC connections. This error will automatically clear once the charger is reset by cycling DC.
Alarm	E005	Algorithm Specific Alarm	Contact Support for details if this alarm occurs.
Alarm	E006	Battery Temperature Sensor Short Circuit	Check temperature sensor wiring for short to ground then restart the charge.
Alarm	E007	Charge Amp-Hour Limit Exceeded	Safety limit exceeded. Possible causes: Poor battery health. Very deeply discharged battery. Poorly connected battery. High parasitic loads on battery while charging. Possible solutions: Replace battery pack. Check DC connections. Disconnect parasitic loads. This error will automatically clear once the charger is reset by cycling DC.
Alarm	E008	Battery Temperature Out of Range	Possible battery temperature sensor error. Check temperature sensor and connections. Reset charger. This error will automatically clear once the condition has been corrected.
Alarm	E009	Battery Temperature Changing Too Quickly	Check loose/corrosion on output cable or bad configuration if the battery temperature sensor is used for charge control.
Alarm	E010	Charger Output Short Circuit	Charger DC terminals in contact with each other while charging. Check for short circuit in charging and battery cables.
Alarm	E011	Charger Disabled By External Command	Charger has been disabled by an external controller over the CANbus network. This error is logged in the data log and the charger sends out a CAN message. It is not displayed.
Alarm	E012	Charger Output Reverse Polarity	Battery is connected incorrectly. Check the battery connections. This error will automatically clear once the condition has been corrected.
Alarm	E013	Charger Output Current Not Accepted	Battery voltage is detected but the charger is unable to output current. This is normally caused by an electrical device connected between the charger and the battery which passes through voltage but not current. Poor connections can also cause this. Ensure the charger is properly connected to approved equipment. This error will automatically clear once the charger is reset by cycling DC or AC.
Alarm	E014	Configuration Error - Charger Cannot Support Number of Battery Cells	The charger will need to be reflashed to the correct settings.
Alarm	E015	Configuration Error - Algorithm Does Not Support Target Voltage Scaling	The charger will need to be reflashed to the correct settings.

This document lists fault (F_) and error (E_) codes on these chargers. Most of these will be reported over CAN and logged. Not all will be displayed on chargers with a user interface. If a unit is not functioning and nothing is indicated or logged, check and cycle both AC and DC. If this condition persists, replace the charger.

Type	Code	Description	Troubleshooting and/or Recommended Actions
Alarm	E016	Charger Programming Failure - General	Retry by removing and re-inserting the USB drive. Ensure correct files are being used. Ensure the USB Flash Drive is properly formatted (FAT recommended) and retry. Try a different USB drive. If error persists, contact Support.
Alarm	E017	USB Operation Failure	This could be caused by a faulty USB drive or connections. If it persists, try a different USB drive.
Alarm	E018	Charger Programming Failure - Corruption	Retry by removing and re-inserting the USB drive. Ensure correct files are being used. Ensure the USB Flash Drive is properly formatted (FAT recommended) and retry. Try a different USB drive. If error persists, contact Support.
Alarm	E019	Charger Programming Failure - Incorrect Software	The charger hardware does not support the software version being programmed. Existing software is left running. Contact Support.
Alarm	E020	No Active Algorithm Selected	Select a charge profile using the button or reflash the charger.
Alarm	E021	High Battery Voltage Error While Charging	Battery Voltage is too high as detected by the algorithm. Check the battery voltage and cable connections. This error will automatically clear once the condition has been corrected.
Alarm	E022	Low Battery Voltage Error While Charging	Battery Voltage is too low as detected by the algorithm. Check the battery voltage and cable connections. This error will automatically clear once the condition has been corrected.
Alarm	E023	AC Voltage High	AC voltage is too high. Connect charger to an AC source that provides stable AC between 85 - 270 VAC / 45-65 Hz. This error will automatically clear once the condition has been corrected.
Alarm	E024	Charger Initialization Failure	The charger has failed to turn on properly. Disconnect AC and battery for 30 seconds before retrying. If Error persists, contact Support.
Alarm	E025	AC Voltage Unstable and Low	AC source is unstable. Could be caused by undersized generator and/or severely undersized/long AC cables. Connect charger to an AC source that is stable and between 85 - 270 VAC / 45-65 Hz. This error will automatically clear once the condition has been corrected.
Alarm	E026	USB Script Failure	Retry by removing and re-inserting the USB drive. Ensure correct files are being used. Ensure the USB Flash Drive is properly formatted (FAT recommended) and retry. Try a different USB drive. If error persists, contact Support.
Alarm	E027	USB Over Current Fault	USB hardware overcurrent protection has been tripped. Remove and reinsert USB device. If the condition persists then try a different, brand-name USB device.
Alarm	E028	Incompatible Algorithm	The selected charging profile is incompatible with the charger software. Update charger software or select a different charging profile.
Alarm	E029	CAN Bus Physical Layer Error	CAN bus network error. Check the physical CAN connector, wiring, and other CAN modules for correct functioning. Check termination is around 60 ohms.
Alarm	E030	Battery Reporting Error	Charger has received an error from the battery module or it is in a pre-operational state.
Alarm	E031	Internal Charger Power Supply Error	Internal supply rail error detected. Remove AC and battery for minimum 30 seconds and retry charger. If the problem persists contact Support.
Alarm	E032	Missing CAN Messages	CAN heartbeats or PDOs were received and then timed out. Check other CAN devices for function.
Alarm	E033	Configuration Error - Target Voltage Too High	The charger configuration is asking for more voltage than the charger can deliver. Charger reflash is required to correct this issue.
Alarm	E034	Configuration Error - Battery Capacity Not Supported	Charger is configured to with capacity scaling but algorithm selected does not support this feature. Select a scalable algorithm or reflash the charger.

This document lists fault (F_) and error (E_) codes on these chargers. Most of these will be reported over CAN and logged. Not all will be displayed on chargers with a user interface. If a unit is not functioning and nothing is indicated or logged, check and cycle both AC and DC. If this condition persists, replace the charger.

Type	Code	Description	Troubleshooting and/or Recommended Actions
Alarm	E035	Configuration Error - Target Voltage Too Low	The charger configuration is asking for voltage below 20% of the charger nominal. Charger reflash is required to correct this issue.
Alarm	E036	Battery Temperature Open Circuit	Check if sensor is connected correctly. Install a temperature sensor. Change to an algorithm that does not require a temperature sensor.
Alarm	E037	Charger Programming Failure - CAN	Re-try CANOpen download or re-program using the USB
Alarm	E038	Cooling Fan Error	Inspect fan to make sure the power wires are connected and the fan blades are not obstructed by debris.
Alarm	E039	Button Stuck Down	Inspect for objects on or near the button or damage to the button. If alarm persists, replace charger.
Alarm	E040	Cooling Fan Voltage Too Low	Ensure that the the fan is not stuck or drawing excess current, and that the correct fan part is installed.
Alarm	E041	Software Error - General	Software internal configuration error, ensure configuration settings are correct and reflash charger
Alarm	E042	Configuration Error - CAN	Software internal configuration error, ensure configuration settings are correct and reflash charger
Alarm	E043	CANopen PDO CRC Mismatch	Power cycle all CAN nodes and charger. Error will clear once sequence counter updates. Reflash charger if this persists. CAN only - not shown on display
Alarm	E044	CANopen PDO Sequence Count Not Changing	Power cycle all CAN nodes and charger. Error will clear once sequence counter updates. Reflash charger if this persists. CAN only - not shown on display
Alarm	E045	Charger Output Open Circuit	Charger did not see enough battery voltage. Connect the battery in order to start charging. This alarm is only displayed if configured.
Alarm	E046	CAN - Invalid PDO Length	Power cycle all CAN nodes and charger. Error will clear once sequence counter updates. Reflash charger if this persists.
Alarm	E047	Reserved	For internal use
Alarm	E048	Stackable Charging - Multiple Masters	Check the wiring harness to ensure only one charger has pins populated to be parallel charging master.
Alarm	E049	Stackable Charging - More Secondary Chargers Than Expected	Make sure the right number of chargers are on the bus for this fixed configuration. Reset chargers to check if this alarm persists.
Alarm	E051	Stackable Charging - No Master	Master device may be disconnected or powered down. Check wiring harness. Check configuration of devices. Reflash Master charger
Alarm	E063	Stackable Charging - Incompatible Secondary Charger(s)	Query the master to identify which secondary has the bad configuration or interface version.
Alarm	E050	Stackable Charging - Single Charger Detected Stackable Messages	Check the configuration of all chargers that are sharing this bus.
Alarm	E052	Stackable Charging - Fewer Secondary Chargers Than Expected	Secondary chargers may be disconnected or powered down. Check the wiring and power to the secondary chargers. The alarm will automatically clear when the missing chargers come back online.
Alarm	E054	Stackable Charging - Secondary Charger Reverse Polarity	Check the DC connections of all chargers and the battery.
Alarm	E055	Stackable Charging - Secondary Charger DC Voltage Mismatch	Either they are disconnected from each other or there is an excessive series resistance which may result in cable overheating. Check DC output wiring of the entire stack. The problem might be due to loose or corroded connections in the cabling.

This document lists fault (F_ __) and error (E_ __) codes on these chargers. Most of these will be reported over CAN and logged. Not all will be displayed on chargers with a user interface. If a unit is not functioning and nothing is indicated or logged, check and cycle both AC and DC. If this condition persists, replace the charger.

Type	Code	Description	Troubleshooting and/or Recommended Actions
Alarm	E053	Stackable Charging - Communications Lost With Secondary Charger(s)	Check wiring harness and power to secondary chargers. Check to see if Secondary Chargers are issuing faults of their own.
Alarm	E057	Reserved	Customer specific implementation
Alarm	E058	Reserved	Customer specific implementation
Alarm	E059	J1939 Address Conflict	Investigate and disconnect non-compliant device from the bus. Alternatively change the charger's configuration to exclude the conflicted address from its allowed range of addresses.
Alarm	E060	CAN Communications Never Received	Charger is waiting for this message to start. Check CAN cabling. Ensure nodes configured to send expected messages
Alarm	E061	CAN Battery Current Report Mismatch	The charger compares the Battery written current with its output current. Check that the right current is being sent to the charger. Check if the output cable has a parallel branch.
Alarm	E062	CAN Battery Voltage Report Mismatch	The charger compares the Battery written voltage with its output voltage. Check that the correct voltage is being sent to the charger. Check that the output cable resistance matches the charger setting. Check for other sources of voltage drop.
Alarm	E056	Stackable Charging - Secondary Charger Fault or Alarm	Check for alarms and faults reported by the secondary chargers.
Alarm	E064	J1939 Address - Charger Failed to Claim	The most likely cause of this problem is that two or more chargers, configured for the same fixed address, have been connected to the same bus in error. Alternatively there could be a configuration issue and the addresses available to the charger are already being used by other customer devices on the bus.
Alarm	E065	J1939 Address - Other Device Failed to Claim	Read SPN 611 from the charger(s) that has raised this alarm. This will contain the 64-bit J1939 "Name" of the device that could not claim its address (see J1939-81 Network Management, Feb 2016, Section 4.2.1). If this device is another Delta-Q charger (manufacturer code 800, function Id 141) and this is a stackable charging system then possible causes include: i) Incorrectly configured chargers ii) Address conflicts exist between the charger and other devices on the bus iii) Master/Secondary wiring fault. The alarm will be cleared on charger reset - but may immediately trigger if the address
Alarm	E066	Battery Voltage Higher Than Configured Maximum	Check if the charger is connected to the right battery, or the maximum voltage configured is too low.
Alarm	E067	CAN Physical Layer Error - Before Messages Received	CANbus network error. Check the physical CAN connector, electrical bus conditions and other CAN modules for correct functioning. For example check termination resistance is approximately 60ohms.
Alarm	E068	Missing CAN Messages While Not Charging	Monitored messages (Heartbeat, PGN, PDO) lost while charger output off. Check the networked CANbus device(s) for correct function and messages.
Alarm	E069	Accessory Power Output Overcurrent	Accessory Power Output (APO) has too much load, please check circuits attached to Accessory Power Output (APO) for shorts or other circuit faults.
Alarm	E087	Charger Error Monitor Triggered	Internal error has been flagged due to not generating the regular "watchdog" message. Check for low AC voltage or other abnormal conditions. If this error re appears, replace the charger.

This document lists fault (F_ __) and error (E_ __) codes on these chargers. Most of these will be reported over CAN and logged. Not all will be displayed on chargers with a user interface. If a unit is not functioning and nothing is indicated or logged, check and cycle both AC and DC. If this condition persists, replace the charger.

Type	Code	Description	Troubleshooting and/or Recommended Actions
Alarm	E088	Charger Error Monitor Not Started	Internal error has been flagged due to loss of communications internally within the charger. Check for abnormal conditions. If this error re-appears, replace the charger.
Alarm	E089	Aux DC Output Error	Lost a condition to operate the Aux DC Output. Check: Aux battery voltage between 9.7-14.5V, Traction battery voltage in range (see Design Guide). Could also be internal hardware failure causing Aux DC Output to be off when commanded on by software or key switch.
Alarm	E090	EVSE Failed To Provide AC	Charger is communication with EVSE but it is not providing AC. Check EVSE is connected to AC power. Check cables and connections. Check EVSE hardware or try another EVSE.
Alarm	E091	EVSE Failed To Turn Off AC	Charger is communicating with EVSE but it is not turning off AC. Check EVSE contactor for welding. Check cables and connections. If persists, try another EVSE.
Alarm	E092	Charger Reflash Error	Check the configuration file is appropriate for this charger model. Check use of the correct version of programming tool or protocol.
Alarm	E093	Aux DC Output Short Circuit	Check for wiring errors. Check for faulty or shorted battery cells. Check for too much load on Aux Output.
Alarm	E094	AC Input Voltage High Spikes	Monitor for stable AC voltage. Frequent spikes above 280VAC may damage the charger input.
Alarm	E095	Safe Disconnect Alarm	Safe disconnect pin not connected but the primary contact pin connected. Ensure correct style of connector is used and the pins are installed correctly.
Alarm	E096	Charger Operating Voltage Too Low	Raise charger output voltage above 21.0VDC to reduce thermal stress to internal components.

Type	Code	Description	Troubleshooting and/or Recommended Actions
Fault	F001	DC-DC Circuit Excessive Leakage	Internal charger fault. Remove AC and battery for minimum 30 seconds and retry charger. If it fails again, do not continue to use the charger - replace the unit.
Fault	F002	PFC Circuit Excessive Leakage	Internal charger fault. Remove AC and battery for minimum 30 seconds and retry charger. If it fails again, do not continue to use the charger - replace the unit.
Fault	F003	PFC Circuit Boost Failure	Internal charger fault. Remove AC and battery for minimum 30 seconds and retry charger. If it fails again, do not continue to use the charger - replace the unit.
Fault	F004	Battery Current Sense Circuit Failure	Internal charger fault. Remove AC and battery for minimum 30 seconds and retry charger. If it fails again, do not continue to use the charger - replace the unit.
Fault	F005	DC Relay Circuit - Rationality	Internal charger fault. Remove AC and battery for minimum 30 seconds and retry charger. If it fails again, do not continue to use the charger - replace the unit.
Fault	F006	Battery Current Sense Circuit Rationality	Internal charger fault. Remove AC and battery for minimum 30 seconds and retry charger. If it fails again, do not continue to use the charger - replace the unit.
Fault	F007	DC-DC Circuit Failure	Internal charger fault. Remove AC and battery for minimum 30 seconds and retry charger. If it fails again, do not continue to use the charger - replace the unit.
Fault	F008	Not Used	
Fault	F009	Internal Software Exception	Internal charger fault. Remove AC and battery for minimum 30 seconds and retry charger. If it fails again, do not continue to use the charger - replace the unit.
Fault	F010	Fault on Connected Charger	Stackable and VCIM systems: Check connected chargers individually for faults.

This document lists fault (F_...) and error (E_...) codes on these chargers. Most of these will be reported over CAN and logged. Not all will be displayed on chargers with a user interface. If a unit is not functioning and nothing is indicated or logged, check and cycle both AC and DC. If this condition persists, replace the charger.

Type	Code	Description	Troubleshooting and/or Recommended Actions
Fault	F016	Internal Aux Relay Circuit Fault	Internal charger fault. Remove AC and battery for minimum 30 seconds and retry charger. If it fails again, do not continue to use the charger - replace the unit.
Fault	F017	Control Pilot Voltage Range Issue	Check EVSE for proper operation. Check control pilot wire for damage. Possible internal hardware fault. If persists, replace the unit.
Fault	F018	Aux Output Fuse Circuit Failure	Internal charger fault. Remove AC and battery for minimum 30 seconds and retry charger. If it fails again, do not continue to use the charger - replace the unit.
Fault	F019	Aux Output Voltage too High	Check AUX DC connected to correct voltage battery (12V or 24V). Possible internal hardware fault. If persists, replace the unit.
Fault	F020	Internal Aux DCDC Short Circuit	Internal charger fault. Remove AC and battery for minimum 30 seconds and retry charger. If it fails again, do not continue to use the charger - replace the unit.
Fault	F021	Internal Temperature Sensor Fault	Internal charger fault. Remove AC and battery for minimum 30 MINUTES and retry charger. If it fails again, do not continue to use the charger - replace the unit.
Fault	F022	Internal Aux DCDC Circuit Failure	Internal charger fault. Remove AC and battery for minimum 30 seconds and retry charger. If it fails again, do not continue to use the charger - replace the unit.
Fault	F023	PFC Circuit Performance Issue Detected	Internal charger fault. Remove AC and battery for minimum 30 seconds and retry charger. If it fails again, do not continue to use the charger - replace the unit.
Fault	F024	Internal Aux DCDC Failed to Turn On	Internal charger fault. Remove AC and battery for minimum 30 seconds and retry charger. If it fails again, do not continue to use the charger - replace the unit.
Fault	F025	Internal Hardware Clock Fault	Internal charger fault. Remove AC and battery for minimum 30 seconds and retry charger. If it fails again, do not continue to use the charger - replace the unit.



HOW TO CHANGE BETWEEN TRAINING AND PRO MODE

Note: We recommend the training mode for new operators. This mode limits the speed to 4 mph. Once comfortable with the machine switch to Pro mode. Pro Mode will increase the top speed up to 7 mph.

1. Turn the battery on.
2. Turn the key on.
3. On the screen press the Login button (1st button on the left side).
4. The first section "Super" is for the Superintendent. The passcode for the Super is 78737. "Salsco" is for our use. "Service" is for the technicians use. Each category will have its own passcode. Each category will have different levels of access.
5. Once you have chosen "Super", toggle to the number right of the name. This is where you enter your passcode (78737).
6. Enter passcode one number at a time using the scroll and toggle buttons.
7. Repeat the process until the number is complete.
8. Once complete hit the Enter button.
9. On the speedometer screen hit the Next button twice.
10. Choose between Training or Pro modes.
11. Once you go back to the home screen, the information is set.
12. Turn the key off.
13. Turn the battery off.



REVISIONS	
ISSUE DATE	DESCRIPTION OF CHANGE / EFFECTIVE DATE OF CHANGE
11/11/24	FIRST ISSUANCE OF PARTS MANUAL
	XXXXXXXX

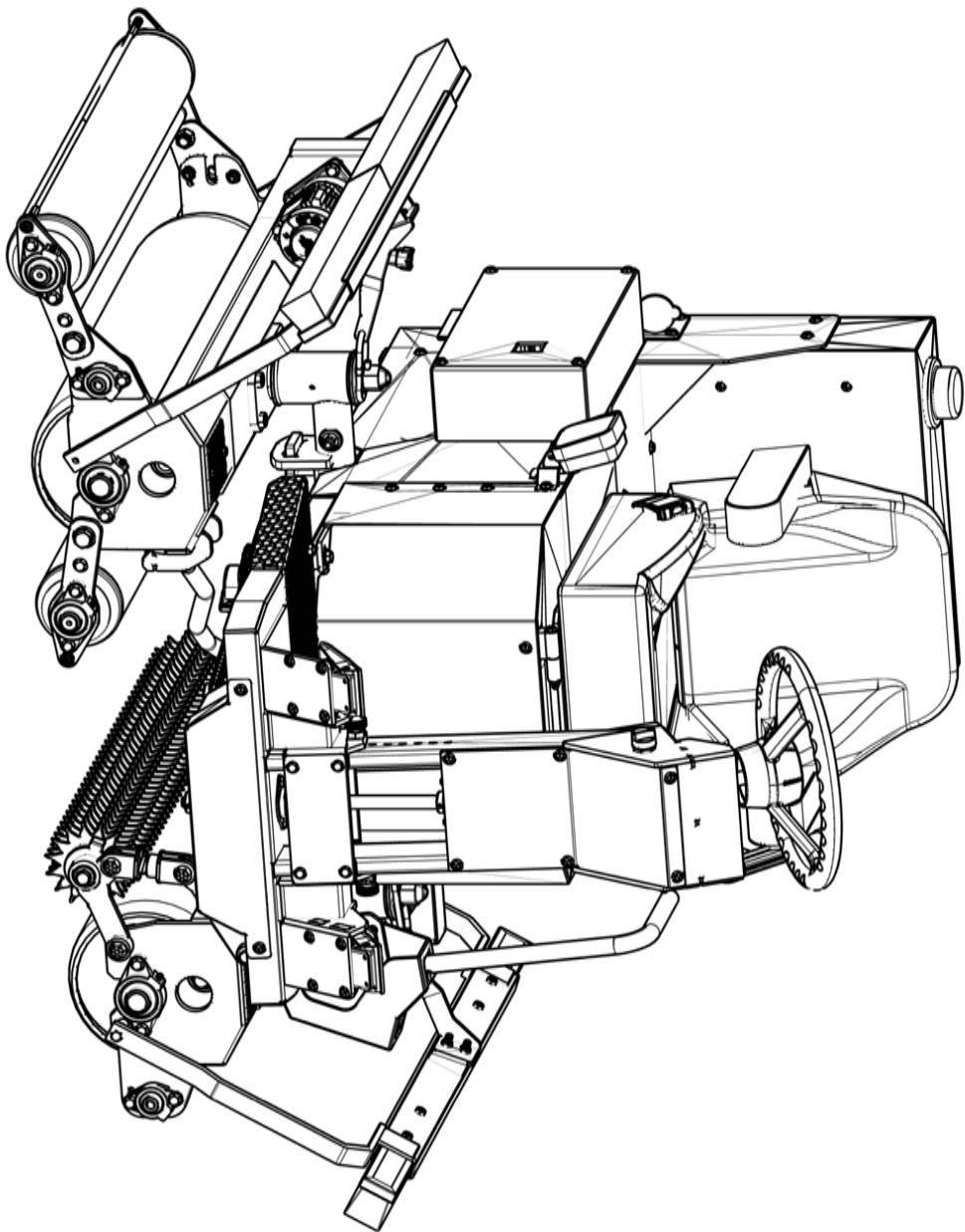

UNIT SHOWN WITH OPTIONAL EQUIPMENT

0009118- ELECTRIC GREENROLLER- MODEL #HP2E

DWG. #01

ITEM	DESCRIPTION	PART NO.	QTY
1	BOX, BATTERY CHARGER	0280097	1
2	BATTERY CHARGER	0315499	1
3	D.O.M. TUBE- Ø1/2" O.D. x 1/8" WALL x 5/8" LG.	RAW MATL	4
4	VOLTAGE REGULATOR/REDUCER- 48V TO 12V	0315500	1
5	FUSE, AIC/ATO AUTOMOTIVE BLADE TYPE, 10A 32 V (NAPA)	782-1108	1
6	AC POBRT PLUG	0315478	1
7	DOOR, BATTERY CHARGER BOX ACCESS	0460129	1
8	AC CHARGER CORD (NOT SHOWN)	0315476	1
9	DC CHARGER CORD (NOT SHOWN)	0315477	1

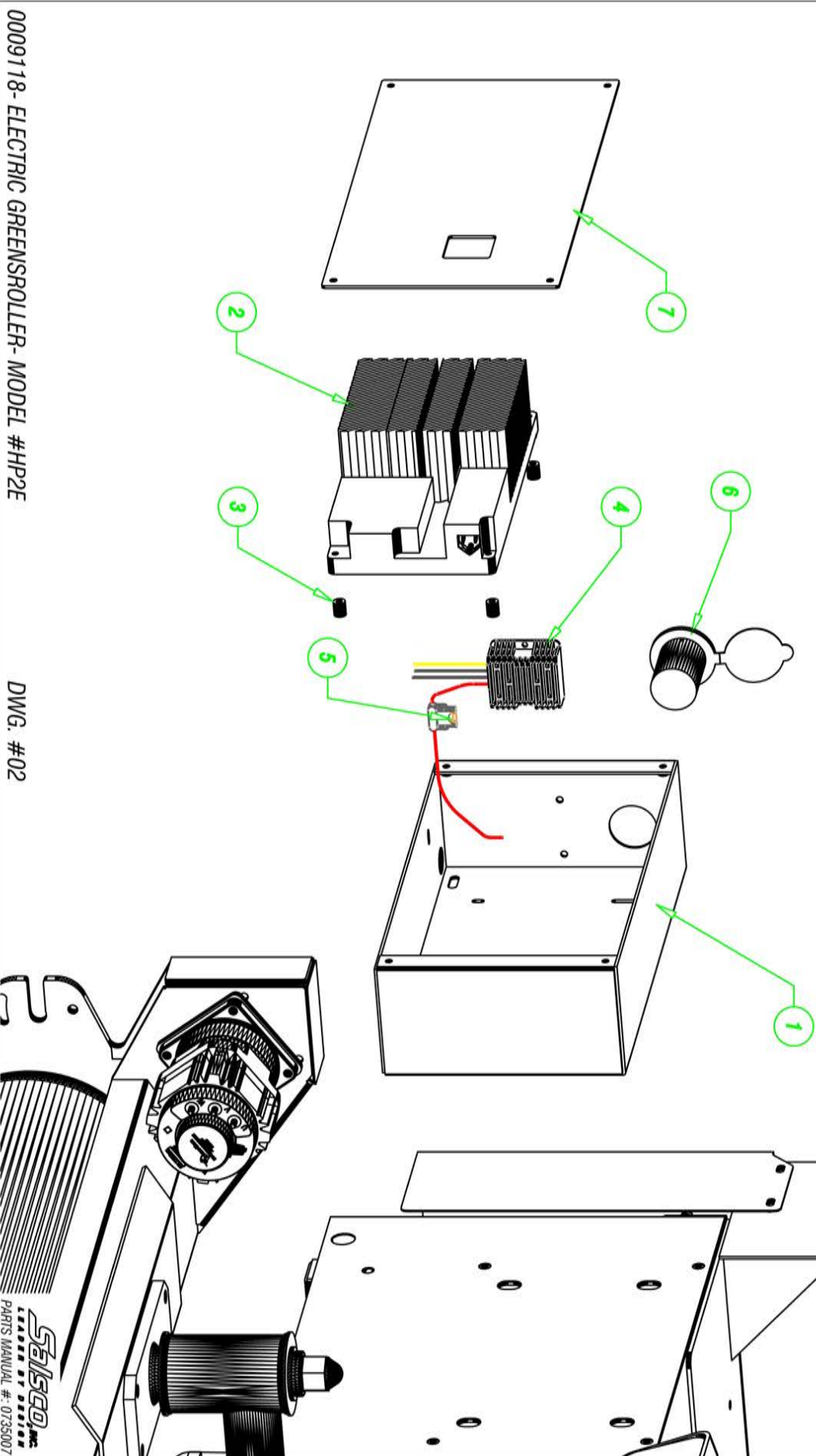

REVISIONS		
ISSUE DATE:	DESCRIPTION OF CHANGE/EFFECTIVE DATE OF CHANGE:	XXXXXX
11/11/24	FIRST ISSUANCE OF PARTS MANUAL	

0009118- ELECTRIC GREENROLLER- MODEL #HP2E

DWG. #02

Salsgard
PARTS MANUAL # 0135007

ITEM	DESCRIPTION	PART NO.	QTY
1	BRACKET, EMERGENCY BRAKE LEVER MOUNTING	0488329	1
2	LEVER, EMERGENCY BRAKE	0333004	1
3	D.O.M. TUBE-Ø1/2" O.D. x .065" WALL x 7/8" LG.	RAW MATL	3
4	SWITCH, SNAP ACTION	0315072	1
5	PLATE, SEAT MOUNTING	0292247	1
6	SEAT, ARM REST	0347013	1
7	SWITCH, SEAT SAFETY	0315389	1
8	CABLE, EMERGENCY BRAKE	0408053	1

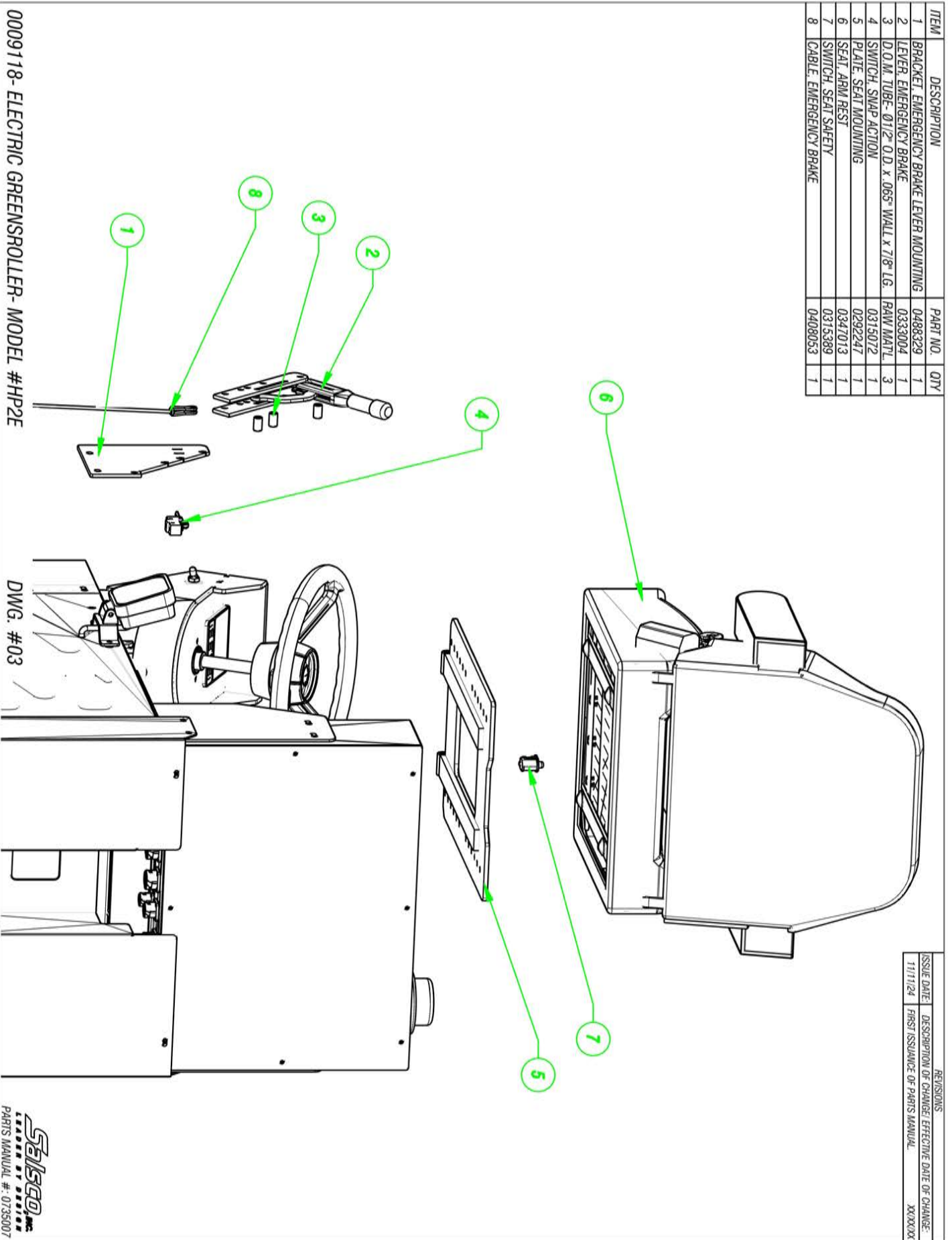

REVISIONS	
ISSUE DATE:	DESCRIPTION OF CHANGE / EFFECTIVE DATE OF CHANGE:
11/11/24	FIRST ISSUANCE OF PARTS MANUAL XXXXXX

ITEM	DESCRIPTION	PART NO.	QTY
1	MOUNT ELECTRICAL CONTROL BOX	0291246	1
2	BOX ELECTRICAL CONTROL	0280098	1
3	PANEL ELECTRICAL COMPONENT MOUNTING	0489469	1
4	D.O.M. TUBE- 05/8" O.D. X .120" WALL X 3/4" LG.	RAW.MATL.	5
5	COVER ELECTRICAL CONTROL BOX	0471558	1
6	GUARD ELECTRICAL CONTROL BOX WIRING	0421808	1
7	BRACKET SQUARE L.E.D. LIGHT MOUNTING	0488153	2
8	FLOOD LIGHT L.E.D. RECTANGULAR	0315413	2

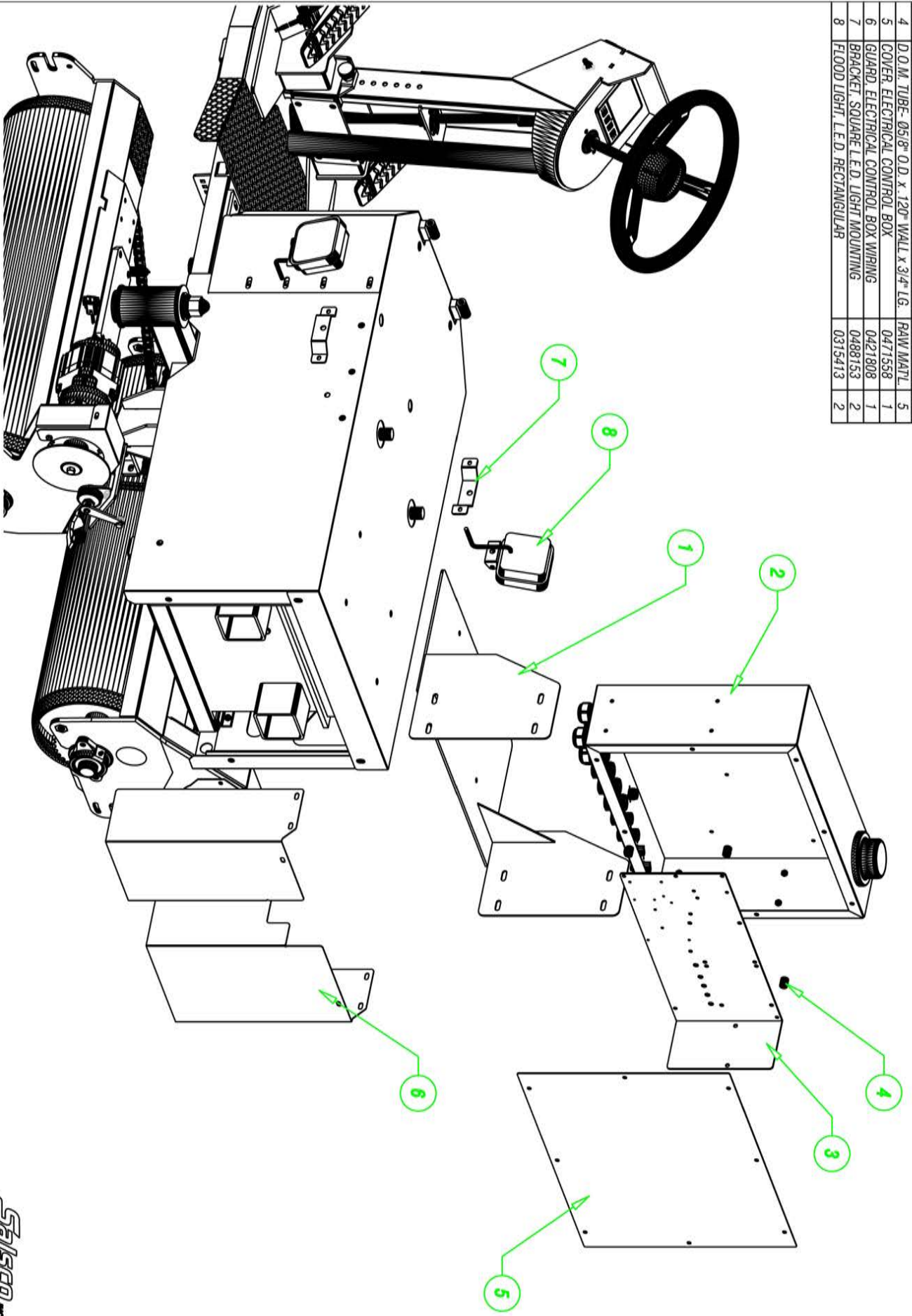

REVISIONS			
ISSUE DATE	DESCRIPTION OF CHANGE	EFFECTIVE DATE OF CHANGE	
11/11/24	FIRST ISSUANCE OF PARTS MANUAL		XXXXXX

0009118- ELECTRIC GREENSROLLER- MODEL #HP2E

DWG. #04

ITEM	DESCRIPTION	PART NO.	QTY
1	BOX, ELECTRICAL CONTROL	0280098	1
2	PANEL, ELECTRICAL COMPONENT MOUNTING	0489469	1
3	TELEMATICS DIAL ANTENNA	0315510	1
4	ELECTRIC MOTOR CONTROLLER w/ PROGRAMMING	0315502	2
5	SPACER- D.O.M. TUBE- .0518" O.D. x .120" WALL x 3/4" LG.	RAW MATL	5
6	POWER DISTRIBUTION MODULE	0315603	2
7	FUSE, MINIFUSE- 60A- 58VDC RATED	0315515	1
8	BUS BAR- 150A COMMON, 300V AC- 48V DC MAX. VOLTAGE	0315546	1
9	RELAY CONTACTOR- 1 FORM X- SPST- NO DIM- 500A- 48VDC	0315513	1
10	CORD GRIP- BLACK PLASTIC- NPT THREADS- FOR .51"-.79" CORD O.D.	0315527	4
11	FUSE HOLDER ADAPTER- LEFT FOR FKH ATO FUSE	0315518	1
12	FUSE HOLDER- 80V- 1 CIRCUIT BLADE- CHASSIS MOUNT	0315516	2
13	FUSE, AUTOMOTIVE- BLADE TYPE- FKS ATO- 5A SLOW-BLOW	0315519	1
14	FUSE, AUTOMOTIVE- BLADE TYPE- FKS ATO- 3A SLOW-BLOW	0315545	1
15	FUSE HOLDER ADAPTER- RIGHT FOR FKH ATO FUSE	0315517	1
16	RELAY, GENERAL PURPOSE CONTACT- 40A- 48VDC	0315539	1
17	DC/ DC CONVERTER SUB-ASSY- 48V TO 12 V REGULATOR (ALSO INCLUDES WIRE EXTENSIONS 0415637, 0415638, 0415639 & 0415640)	0315623	1
18	FUSE, ATO/ ATO AUTOMOTIVE BLADE TYPE, 10A 32 V (MAP4)	782-1108	1

ITEM	DESCRIPTION	PART NO.	QTY
19	CAN BUS SPLITTER- J1939 6-PLACE SPLITTER w/ GOLD PINS	0315521	1
20	TELEMATICS GATEWAY- AIRT- SOFTWARE LOADED	0315509	1
21	MOUNTING CLIP- STAINLESS STEEL- 11mm HOLE	0315529	5
22	HOUSING FOR MALE TERMINALS- BUS BAR- TO- WIRE 12-POSITION	0315533	1
23	PUG, (MALE CONNECTOR)- 12-POSITION, CABLE MOUNT	0315534	1
24	RECEPTACLE (FEMALE CONNECTOR)- 4-POSITION, CABLE MOUNT	0315536	2
25	PUG, (MALE CONNECTOR)- 4-POSITION, CABLE MOUNT	0315537	2
26	HOUSING FOR MALE TERMINALS- BUS BAR- TO- WIRE 6-POSITION	0315530	2
27	PUG, (MALE CONNECTOR)- 6-POSITION, CABLE MOUNT	0315537	2

ISSUE DATE	DESCRIPTION OF CHANGE/ EFFECTIVE DATE OF CHANGE	REVISIONS
11/11/24	FIRST ISSUANCE OF PARTS MANUAL	XXXXXX

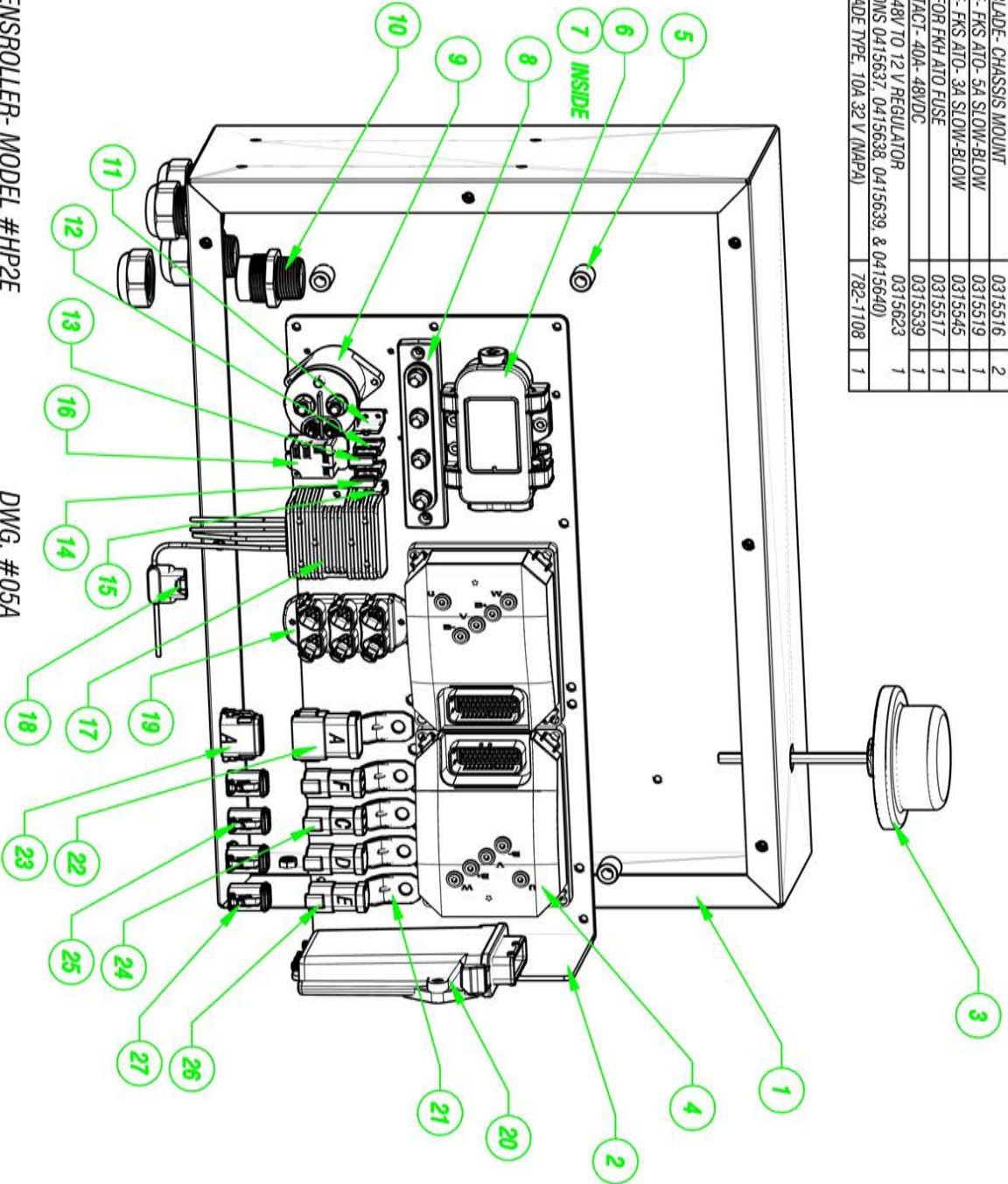

0009118- ELECTRIC GREENROLLER- MODEL #HP2E

DWG. #05A



DESCRIPTION
 WIRE CONNECTIONS FOR TELEMATICS DUAL ANTENNA

REVISIONS
 ISSUE DATE: 11/11/24
 DESCRIPTION OF CHANGE: FIRST ISSUANCE OF PARTS MANUAL
 EFFECTIVE DATE OF CHANGE: XX/XX/XX

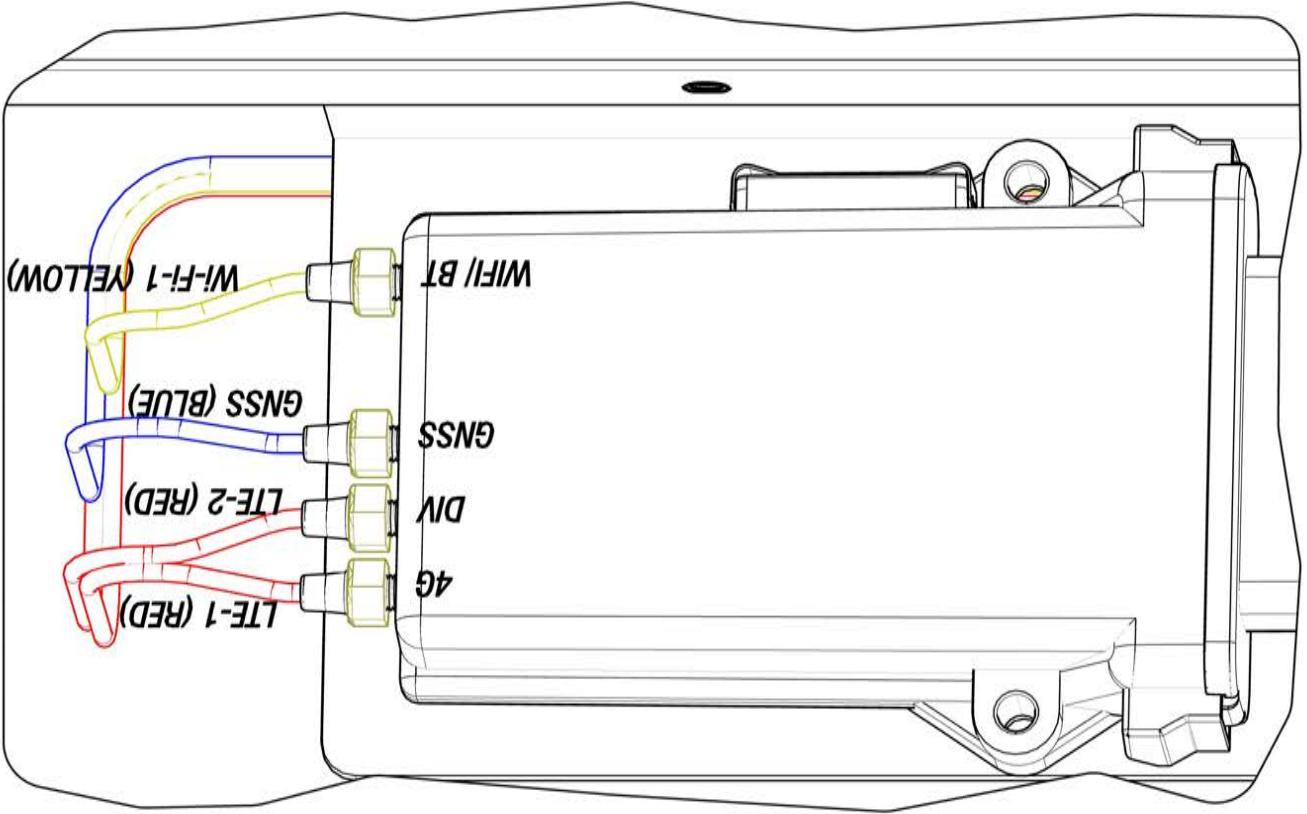
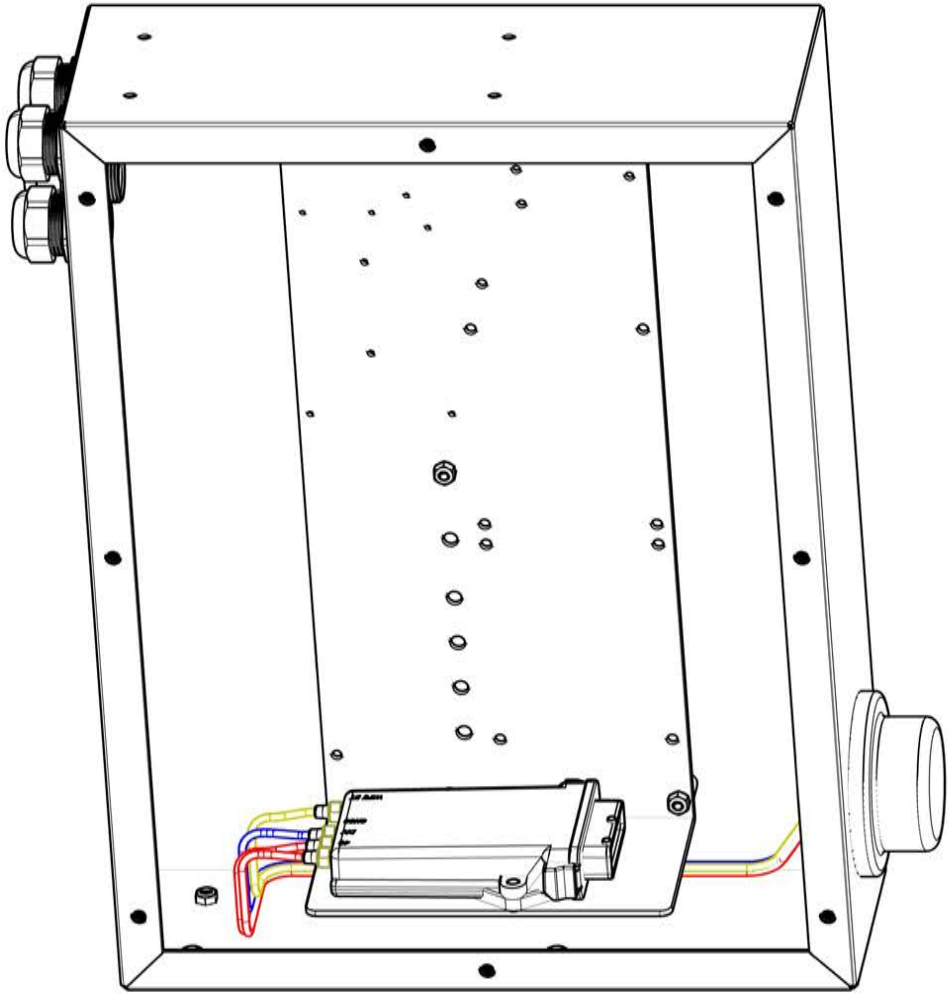

0009118- ELECTRIC GREENROLLER- MODEL #HP2E

DWG. #05B



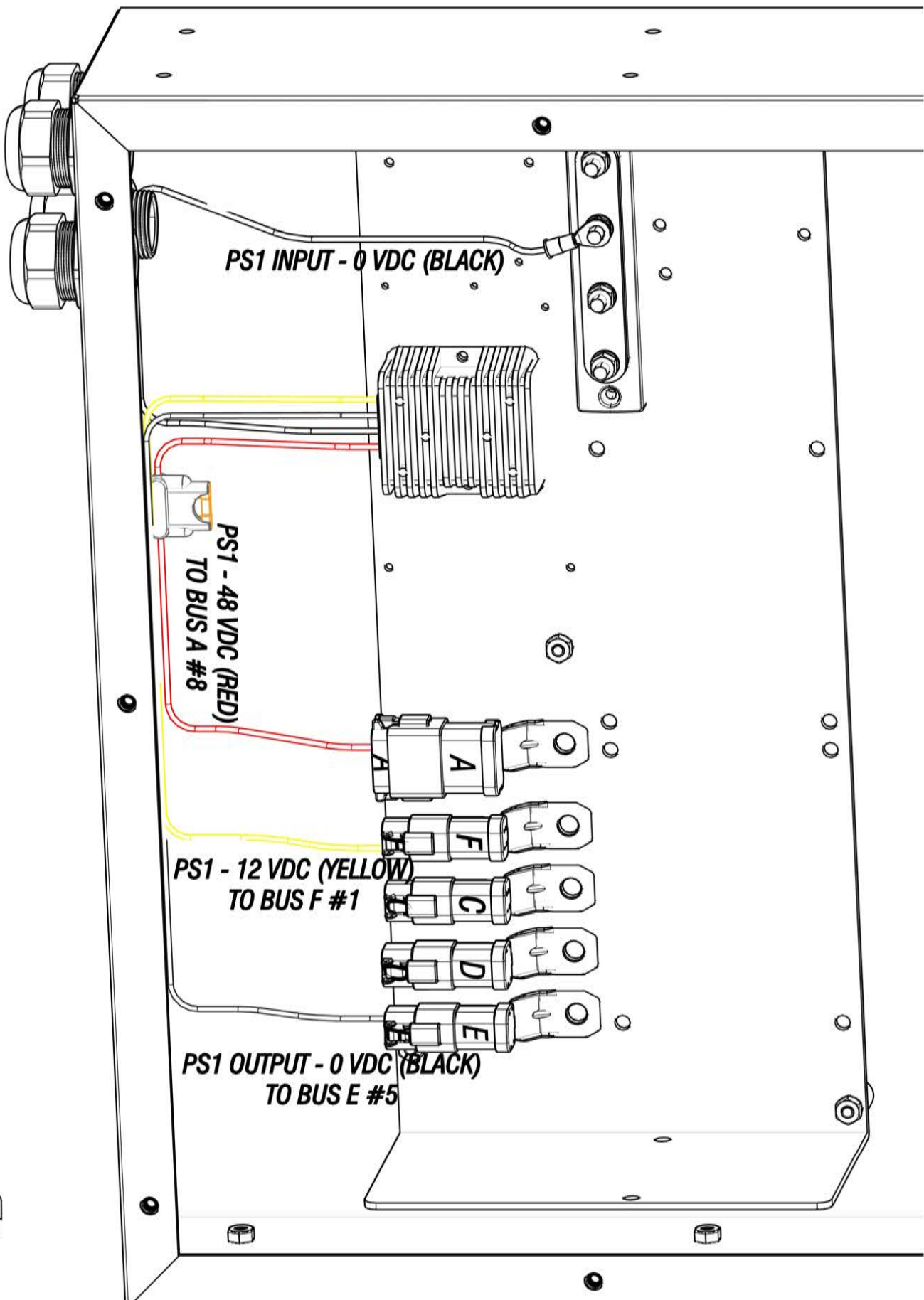

0009118- ELECTRIC GREENROLLER- MODEL #HP2E

DWG. #05C

ITEM	DESCRIPTION	PART NO.	QTY	ISSUE DATE	DESCRIPTION OF CHANGE EFFECTIVE DATE OF CHANGE
1	WIRE- 18GA. RED- 7' LG. SMALL FEMALE SPADE ONE END (CR2 RELAY TOP LEFT TO FUSE #2 (3 AMP))	0415631	1	11/17/24	FIRST ISSUANCE OF PARTS MANUAL XXXXX
2	WIRE- 18GA. BLACK- 8 1/2' LG. SMALL FEMALE SPADE ONE END TO 1/4" RING TERMINAL (CR2 RELAY TOP RIGHT TO BUS BAR (GROUND))	0415633	1		
3	WIRE- 18GA. RED- 23 1/2' LG. LARGE FEMALE SPADE ONE END TO FEMALE PIN (CR2 RELAY COM. TERMINAL (MIDDLE LEFT) TO BUS F SOCKET #3)	0415634	1		
4	WIRE- 18GA. BLACK- 28 1/2' LG. LARGE FEMALE SPADE ONE END TO FEMALE PIN (CR2 RELAY NORMALLY OPEN TERMINAL (BOTTOM LEFT) TO BUS D SOCKET #1)	0415635	1		

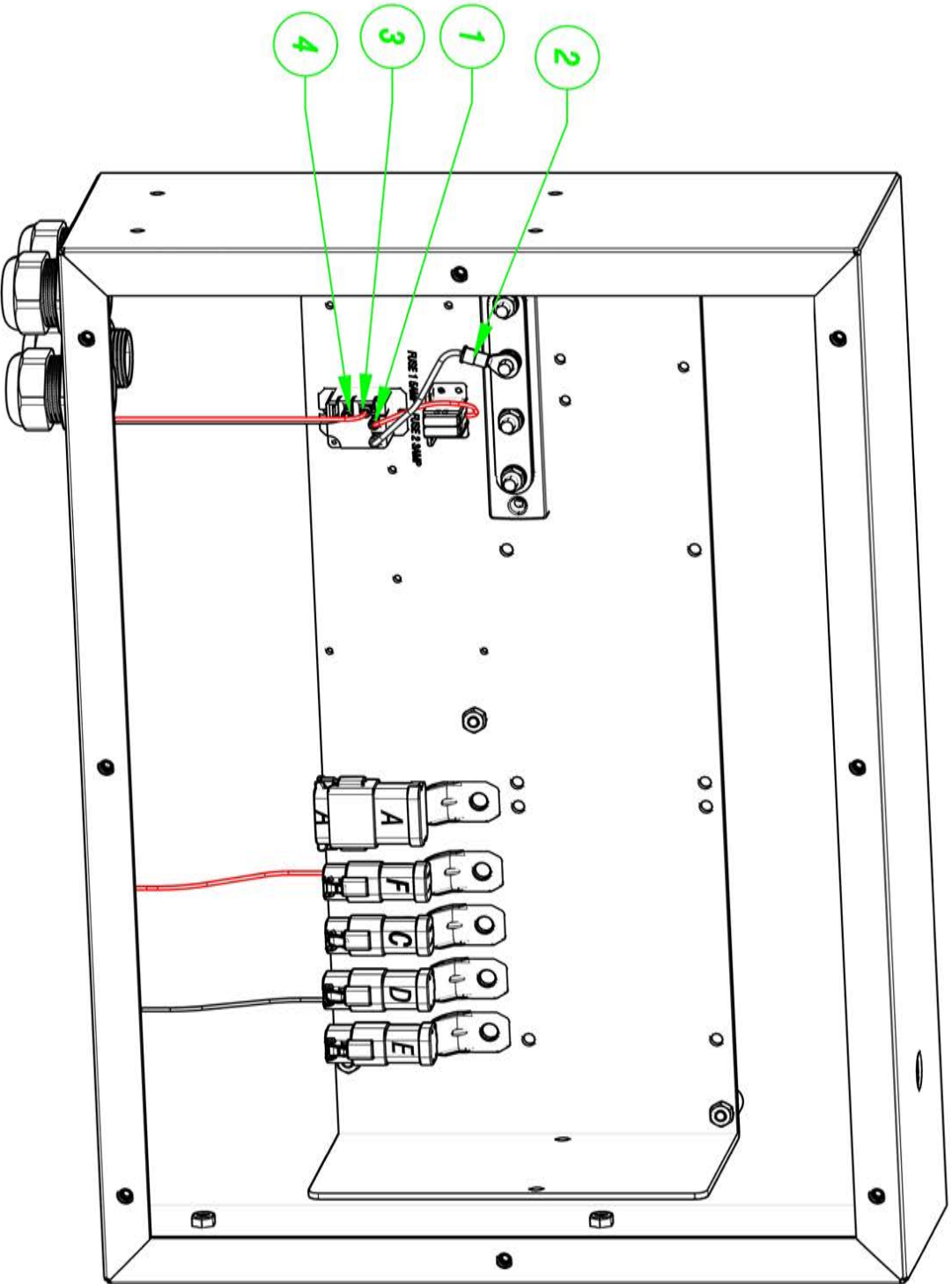

0009118- ELECTRIC GREENROLLER- MODEL #HP2E

DWG. #05D

DESCRIPTION
WIRE CONNECTIONS FOR CR2 RELAY

SELBGO
LEADER BY DESIGN
PARTS MANUAL #. 0735007

ITEM	DESCRIPTION	PART NO.	QTY	DESCRIPTION	REVISIONS
1	WIRE HARNESS, TELEMATICS DATA MODULE (TDM1) ASSY - #HA68121-5320	0315615	1	WIRE CONNECTIONS FOR TELEMATICS DATA MODULE	ISSUE DATE: 11/1/24 DESCRIPTION OF CHANGE: EFFECTIVE DATE OF CHANGE: XXXXXX FIRST ISSUANCE OF PARTS MANUAL: XXXXXX

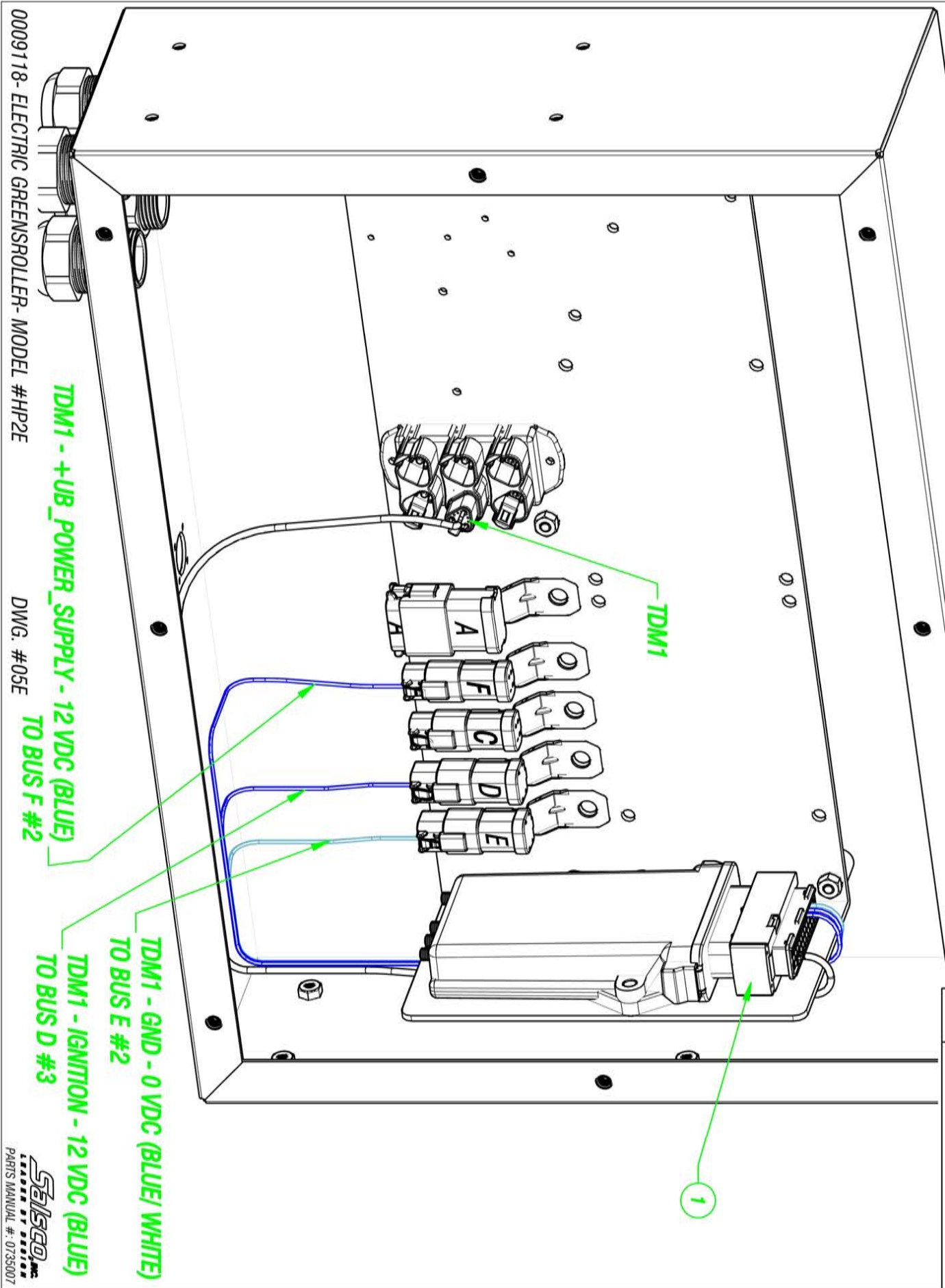

0009118- ELECTRIC GREENROLLER- MODEL #HP2E

DWG. #05E



ITEM	DESCRIPTION	PART NO.	QTY
1	WIRE- 18GA. RED- 9 1/2" LG., 5/16" RING TERMINAL ONE END (ORT SOLENOID BATTERY POSITIVE TO FUSE #1 (5 AMP))	0415629	1
2	WIRE- 18GA. BLUE- 20 1/2" LG., FEMALE PIN ONE END (FUSE #1 (5 AMP) TO BUS A SOCKET #1)	0415630	1
3	WIRE- 18GA. BLUE- 28 1/2" LG., FEMALE PIN ONE END (FUSE #2 (3 AMP) TO BUS C SOCKET #2)	0415632	1

REVISIONS	
ISSUE DATE	DESCRIPTION OF CHANGE/ EFFECTIVE DATE OF CHANGE
11/1/24	FIRST ISSUANCE OF PARTS MANUAL X00000

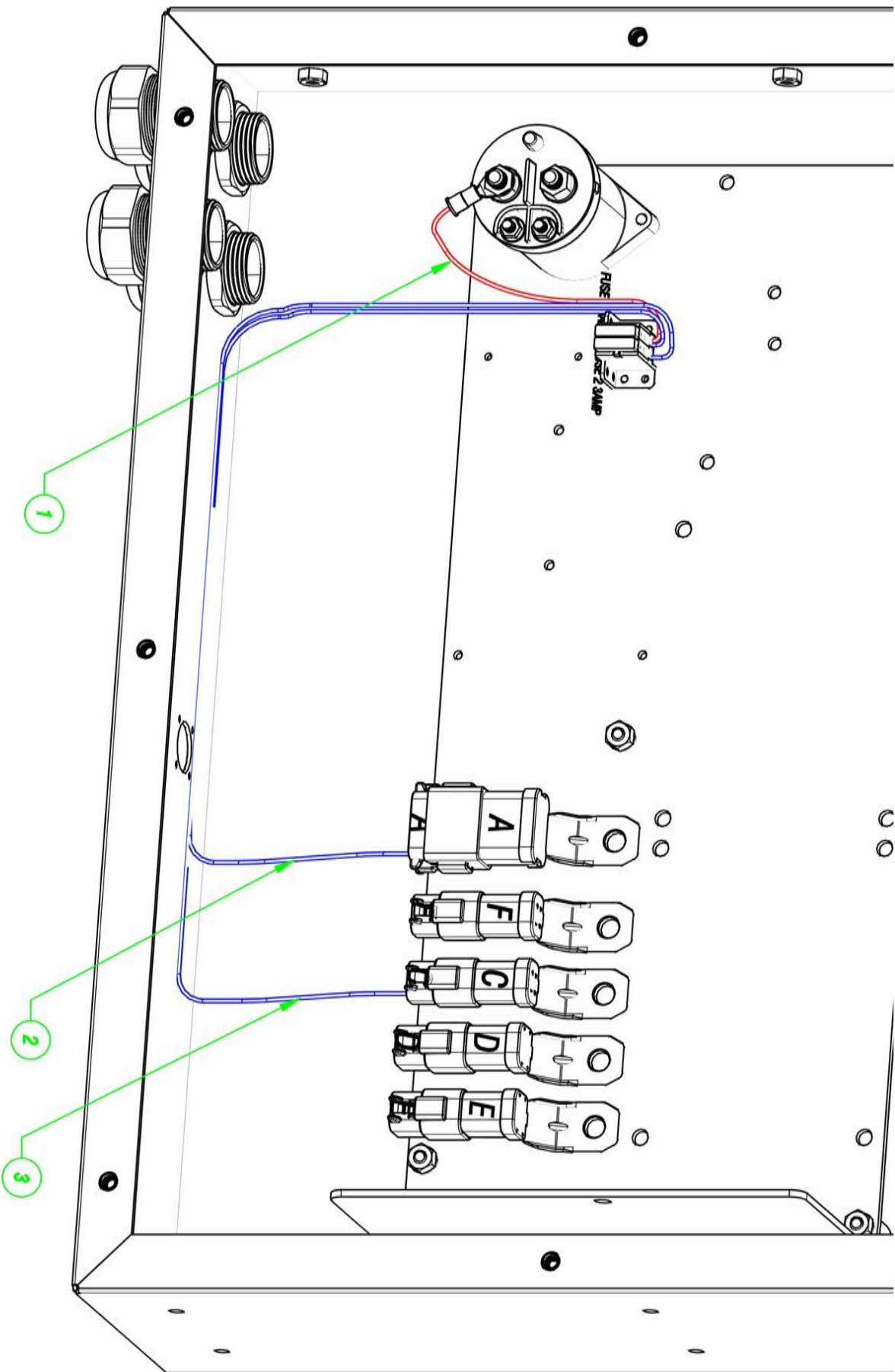

0009118- ELECTRIC GREENROLLER- MODEL #HP2E

DWG. #05F

DESCRIPTION
WIRE CONNECTIONS FOR FUSES #1 & 2

Salsgo
LEADER OF DESIGN
PARTS MANUAL #: 0739007

ITEM	DESCRIPTION	PART NO.	QTY
1	CABLE ASSY - BATTERY POSITIVE - #HA68121-5315	0315612	1
2	CABLE ASSY - BATTERY POWER ASSY - #HA68121-524	0315618	1

REVISIONS	
ISSUE DATE:	DESCRIPTION OF CHANGE EFFECTIVE DATE OF CHANGE:
11/11/24	FIRST ISSUANCE OF PARTS MANUAL XX000X

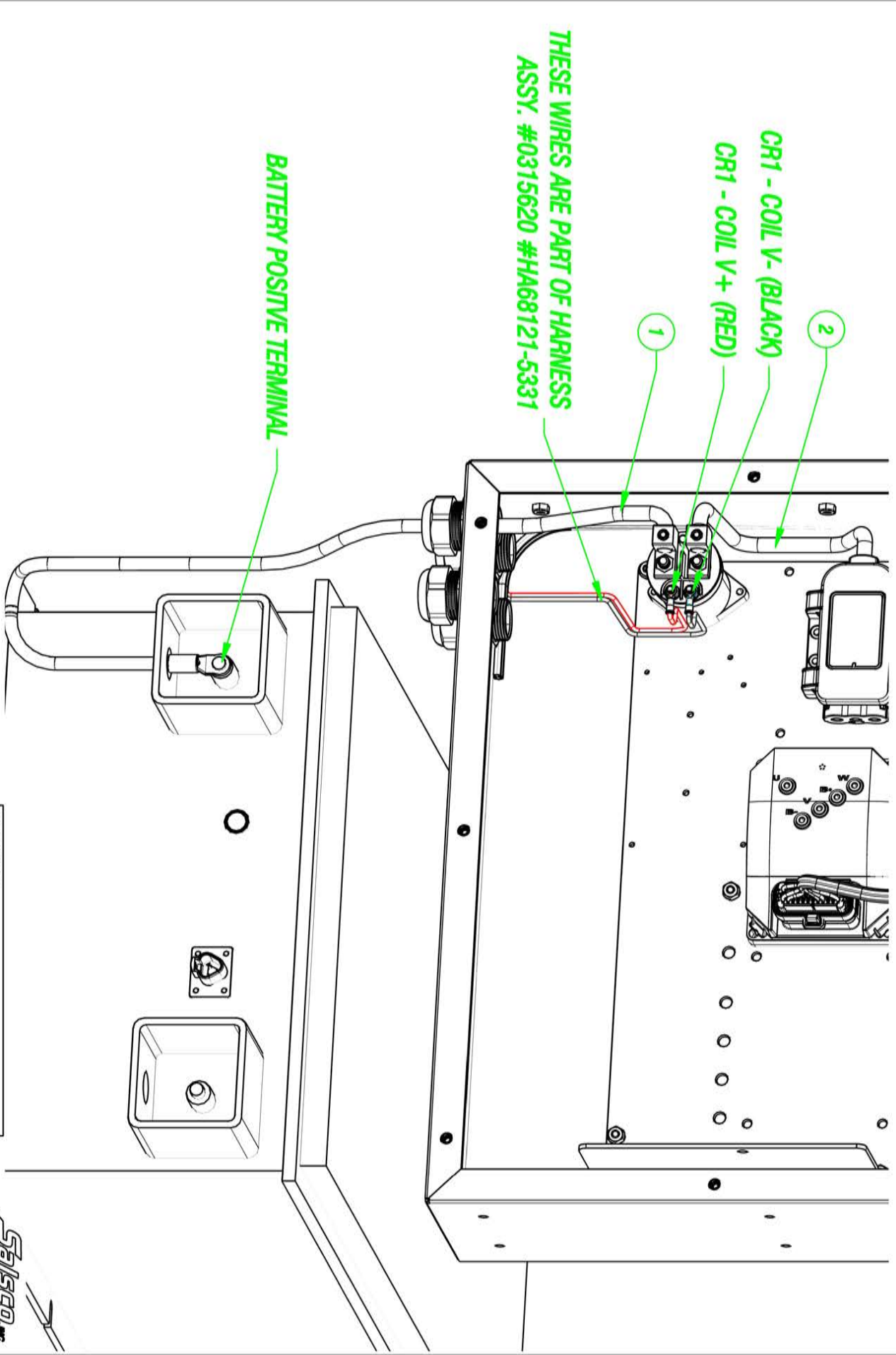

THESE WIRES ARE PART OF HARNESS ASSY. #0315620 #HA68121-5331

CR1 - COIL V- (BLACK)
CR1 - COIL V+ (RED)

BATTERY POSITIVE TERMINAL

0009118- ELECTRIC GREENROLLER- MODEL #HP2E

DWG. #05G

DESCRIPTION
WIRE CONNECTIONS FOR CRT SOLENOID.

Salisco
CREATED BY DESIGN
PARTS MANUAL # - 0735007

ITEM	DESCRIPTION	PART NO.	QTY
1	CABLE ASSY- BATTERY NEGATIVE- #HA68121-5317	0415614	1
2	WIRE- 10GA. RED- 5.3/4" LG. 1/4" RING TERMINAL BOTH ENDS	0415625	1
3	WIRE- 10GA. RED- 23 1/2" LG. 1/4" RING TERMINAL BOTH ENDS	0415626	1
4	WIRE- 10GA. BLACK- 6" LG. 1/4" RING TERMINAL BOTH ENDS	0415627	1
5	WIRE- 10GA. BLACK- 23" LG. 1/4" RING TERMINAL BOTH ENDS	0415628	1

DESCRIPTION
WIRE CONNECTIONS FOR MOTOR CONTROLLER POWER & GROUND

REVISIONS
ISSUE DATE: 11/11/24 DESCRIPTION OF CHANGE/ EFFECTIVE DATE OF CHANGE: XXXXXX
FRST ISSUANCE OF PARTS MANUAL

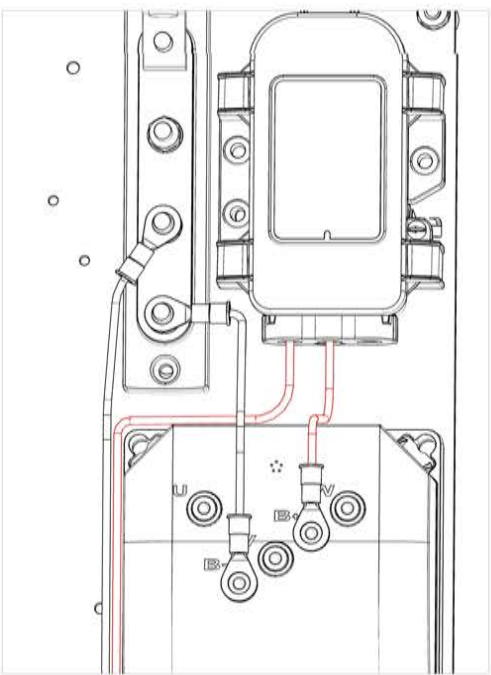

RED WIRES- ATTACH TO TERMINAL B+ ON MOTOR CONTROLLERS
BLACK WIRES- ATTACH TO TERMINAL B- ON MOTOR CONTROLLERS

0009118- ELECTRIC GREENROLLER- MODEL #HP2E

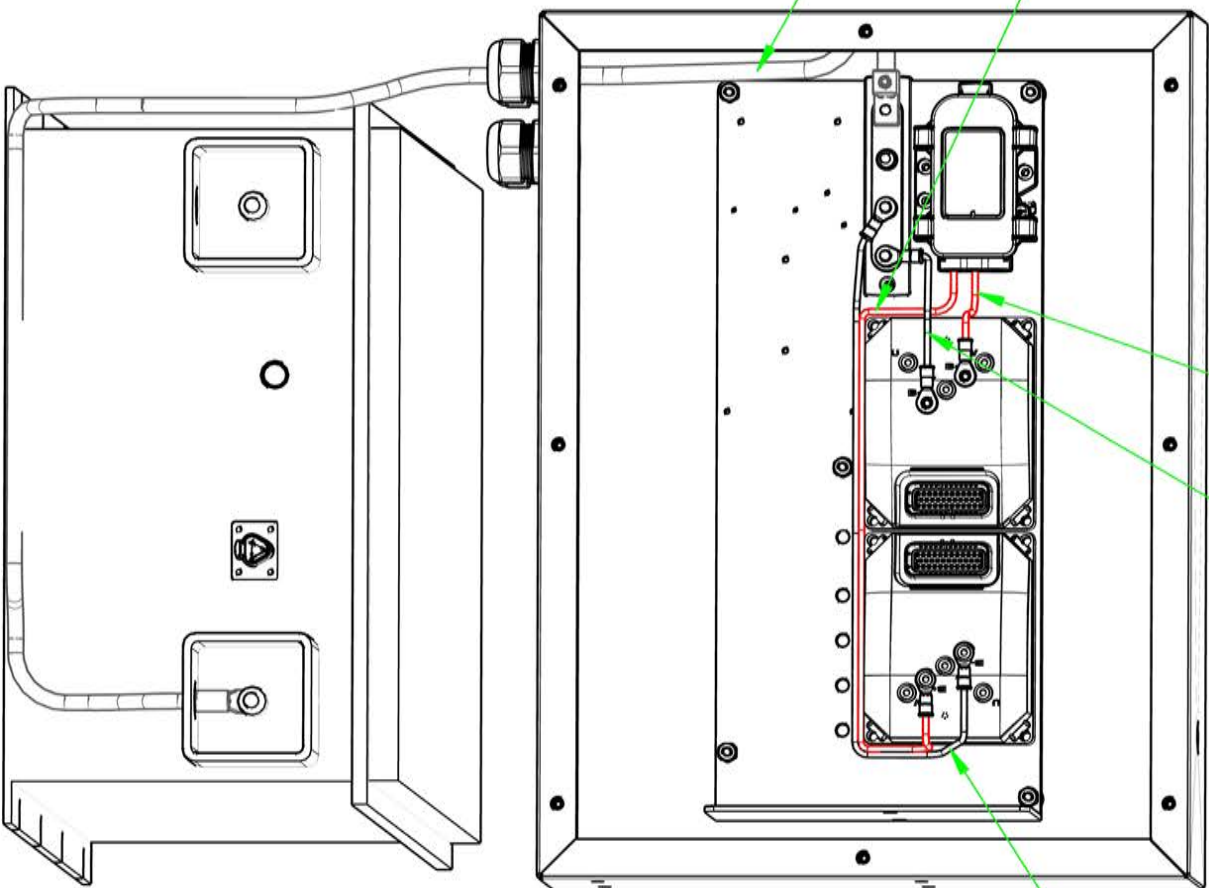

DWG. #05H

ITEM	DESCRIPTION	PART NO.	QTY
1	CABLE, LEFT (M1) DRIVE MOTOR POWER CABLE ASSY- #HA68121-5311	0315610	1
2	CABLE, RIGHT (M2) DRIVE MOTOR POWER CABLE ASSY- #HA68121-5312	0315611	1

DESCRIPTION
WIRE CONNECTIONS FOR MOTOR POWER CABLES.

REVISIONS	ISSUE DATE	DESCRIPTION OF CHANGE/ EFFECTIVE DATE OF CHANGE
	11/11/24	FIRST ISSUANCE OF PARTS MANUAL XXXXXXX

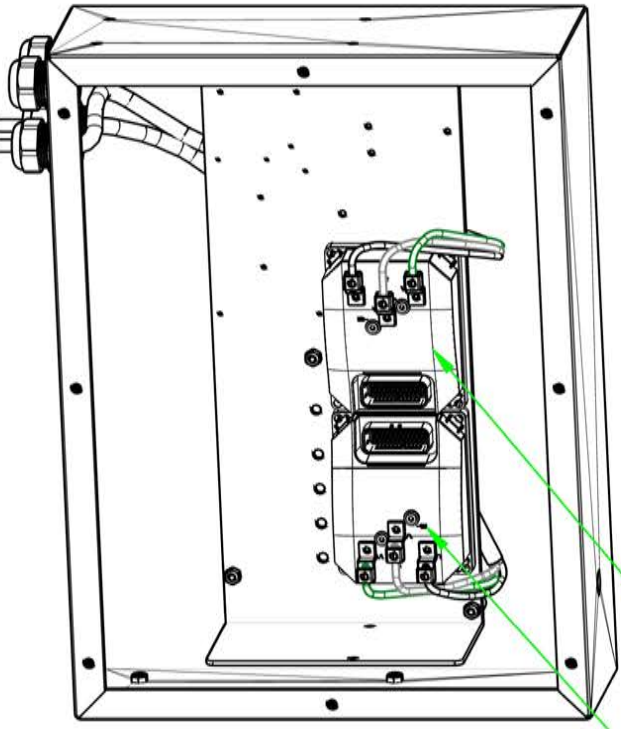
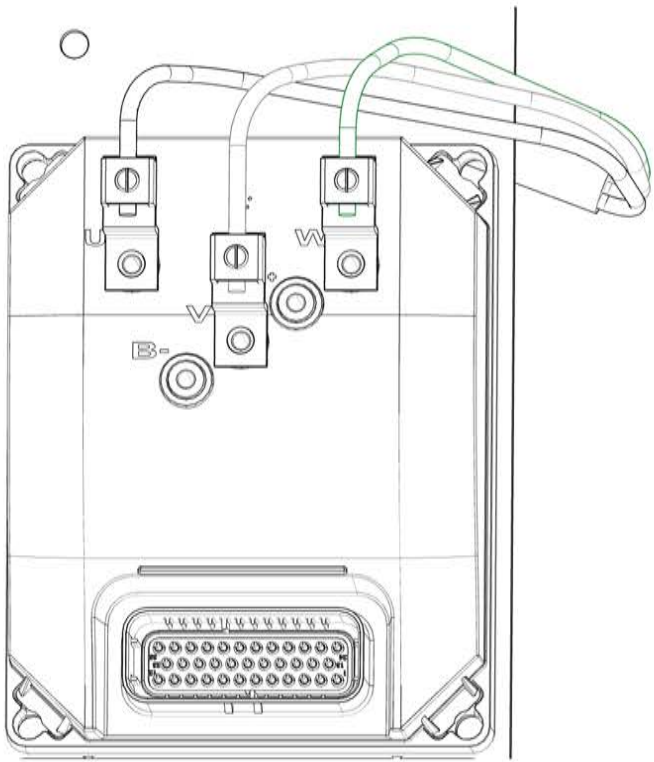

**LEFT (M1) DRIVE
MOTOR CONTROLLER**

**RIGHT (M2) DRIVE
MOTOR CONTROLLER**

BLACK WIRES- ATTACH TO TERMINAL U ON MOTOR & CONTROLLER
 WHITE WIRES- ATTACH TO TERMINAL V ON MOTOR & CONTROLLER
 GREEN WIRES- ATTACH TO TERMINAL W ON MOTOR & CONTROLLER

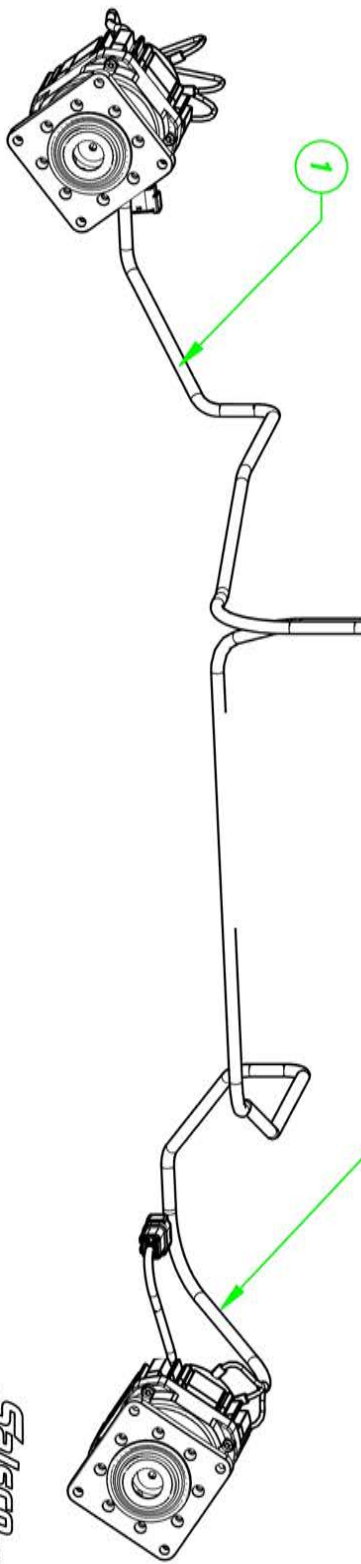

0009118- ELECTRIC GREENROLLER- MODEL #HP2E

DWG. #05J



ITEM	DESCRIPTION	PART NO.	QTY
1	WIRE HARNESS, MC1 (LEFT DRIVE MOTOR CONTROLLER) ASSY. - #HA68121-5331	0315620	1
2	CABLE ASSY, FP1 LEFT FOOT PEDAL - #HA68121-5306	0315607	1
3	GASKET, CLOSED CELL SPONGE - BLACK - FOR 9-PIN RECEPTACLE CONNECTOR	0315540	1
4	GASKET, CLOSED CELL SPONGE - BLACK - FOR 5-PIN RECEPTACLE CONNECTOR	0315542	1

DESCRIPTION
WIRE CONNECTIONS FOR LEFT MOTOR CONTROLLER HARNESS.

ISSUE DATE	DESCRIPTION OF CHANGE	EFFECTIVE DATE OF CHANGE
11/11/24	FIRST ISSUANCE OF PARTS MANUAL	XXXXXX

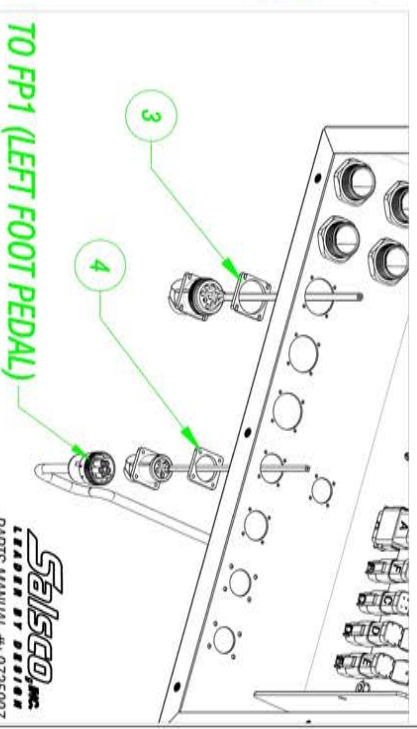
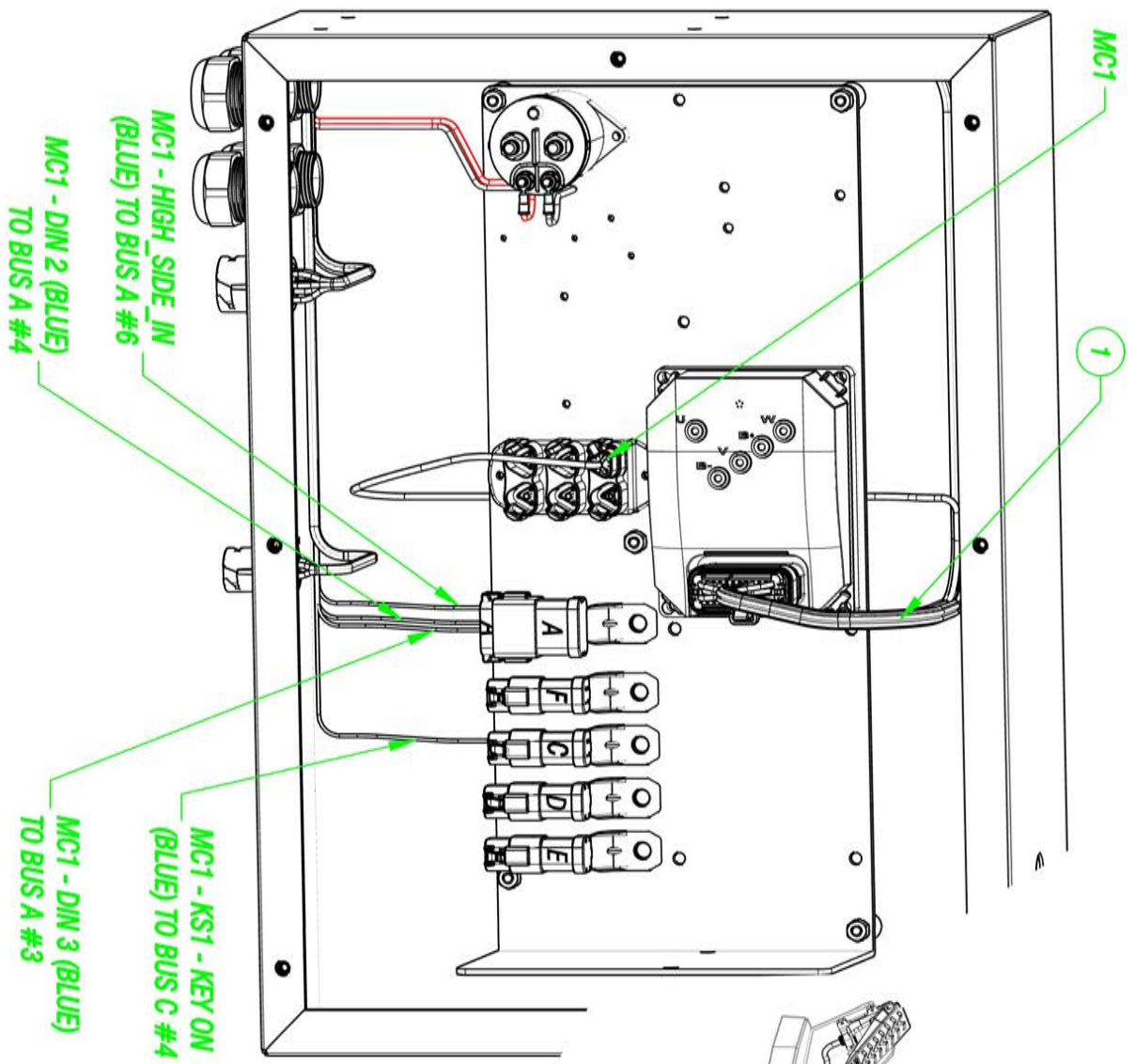
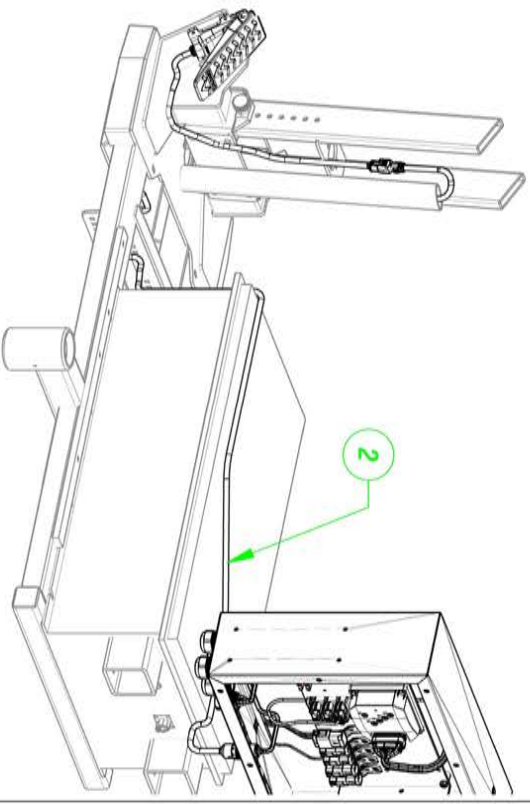

0009118- ELECTRIC GREENROLLER- MODEL #HP2E

DWG. #05K

ST/SGO
 LEADER BY DESIGN
 PARTS MANUAL #: 0735007

ITEM	DESCRIPTION	PART NO.	QTY
1	WIRE HARNESS, MC2 (RIGHT DRIVE MOTOR CONTROLLER) ASSY. - #HA68121-5332	0315621	1
2	CABLE ASSY, FP2 LEFT FOOT PEDAL - #HA68121-5308	0315609	1
3	GASKET, CLOSED CELL SPONGE - BLACK - FOR 9-PIN RECEPTACLE CONNECTOR	0315540	1
4	GASKET, CLOSED CELL SPONGE - BLACK - FOR 5-PIN RECEPTACLE CONNECTOR	0315542	1

DESCRIPTION	ISSUE DATE	DESCRIPTION OF CHANGE / EFFECTIVE DATE OF CHANGE
WIRE CONNECTIONS FOR RIGHT MOTOR CONTROLLER HARNESS.	1/11/24	FIRST ISSUANCE OF PARTS MANUAL XX/XXXX

REVISIONS

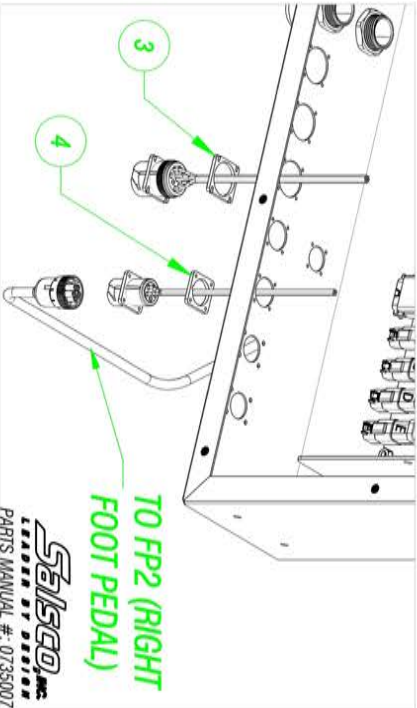
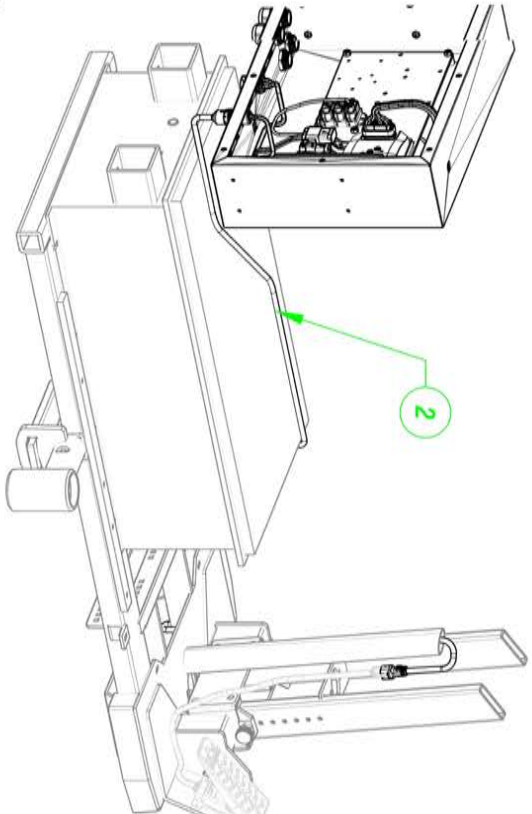
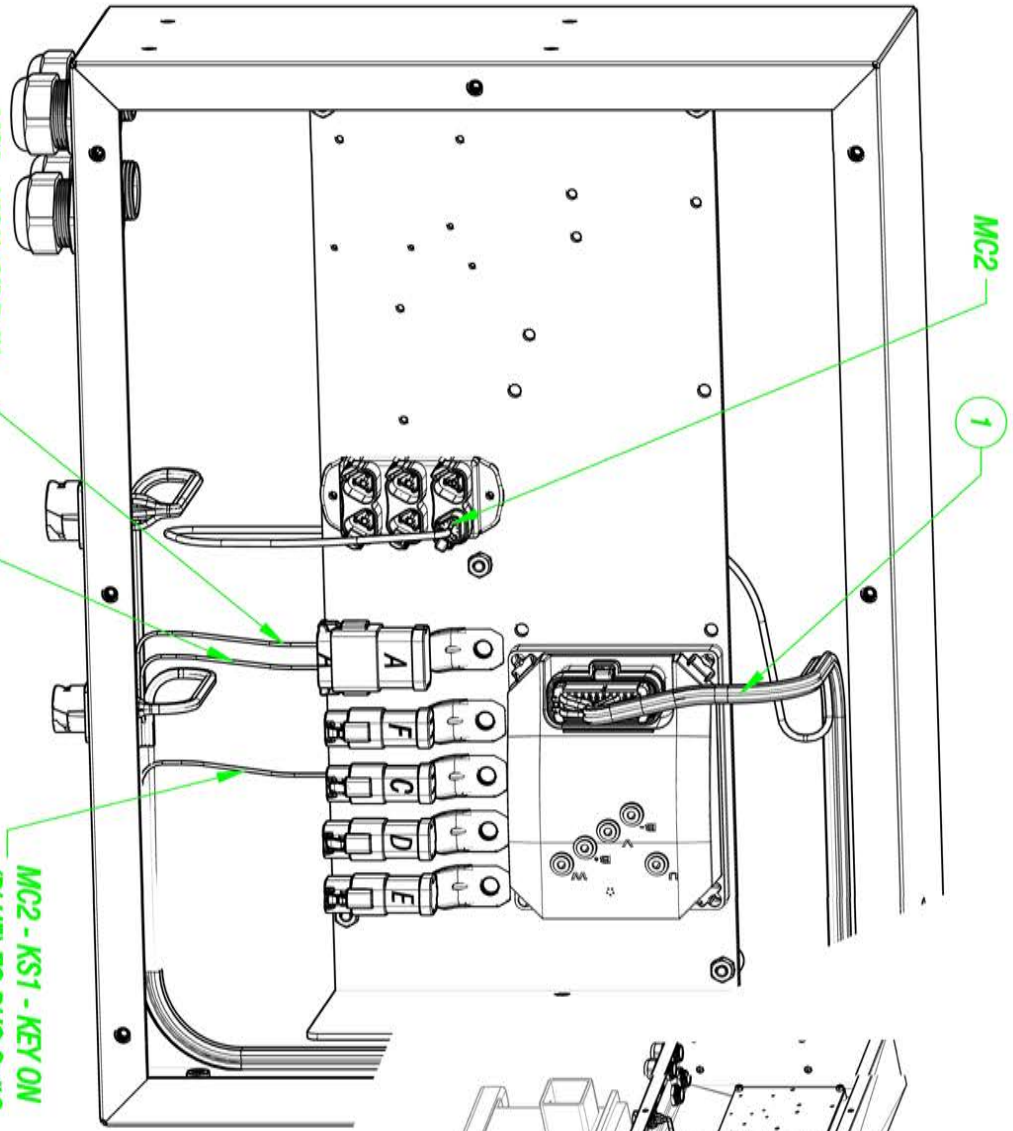

0009118- ELECTRIC GREENROLLER- MODEL #HP2E

DWG. #05L



ITEM	DESCRIPTION	PART NO.	QTY
1	WIRE HARNESS, BATTERY COMMUNICATION ASSY - #HA69121-5323 (INCLUDES GASKET)	0315617	1
2	WIRE HARNESS, LAPTOP COMMUNICATION ASSY - #HA69121-5336 (INCLUDES GASKET)	0315622	1
3	CABLE ASSY, BATTERY COMMUNICATION ASSY - #HA69121-5316	0315613	1

DESCRIPTION
WIRE CONNECTIONS FOR BATTERY & LAPTOP COMMUNICATION

REVISIONS	
ISSUE DATE	DESCRIPTION OF CHANGE EFFECTIVE DATE OF CHANGE
11/11/24	FIRST ISSUANCE OF PARIS MANUAL
	XXXXXXXX

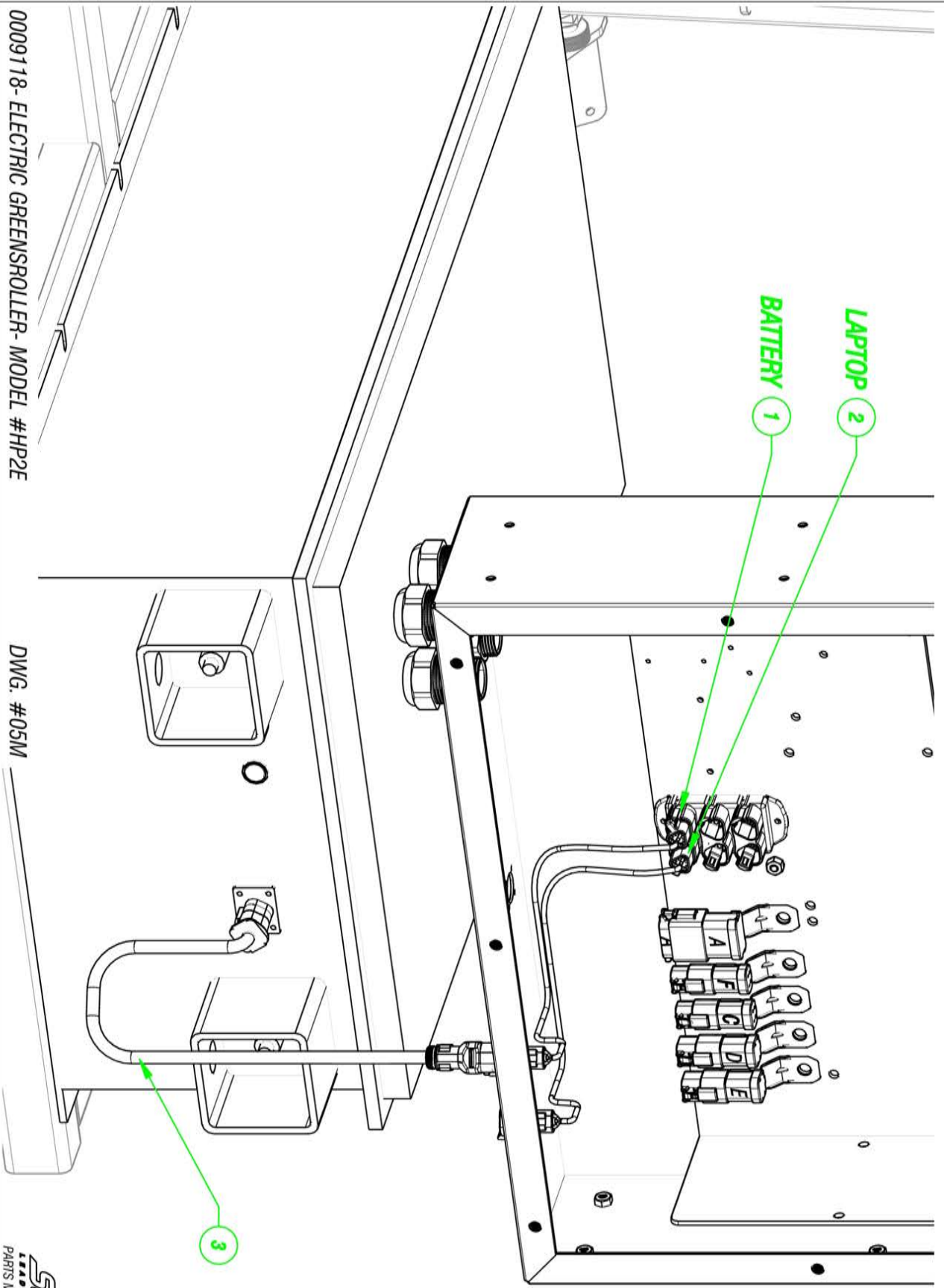

0009118- ELECTRIC GREENROLLER- MODEL #HP2E

DWG. #05M



ITEM	DESCRIPTION	PART NO.	QTY
1	WIRE HARNESS, CONTROL (HMI- DISPLAY) ASSY. - #HA68121-5321	0315616	1
2	CABLE ASSY, OPERATOR- #HA68121-5302	0315605	1
3	WIRE HARNESS, OPERATOR ASSY.- #HA68121-5301	0315604	1
4	GASKET, CLOSED CELL SPONGE- BLACK- FOR 9-PIN RECEPTACLE CONNECTOR	0315540	1

DESCRIPTION	ISSUE DATE	DESCRIPTION OF CHANGE/ EFFECTIVE DATE OF CHANGE	REVISIONS
WIRE CONNECTIONS FOR OPERATOR CONTROLLER HARNESSSES	11/11/24	FIRST ISSUANCE OF PARTS MANUAL	XXXXXX

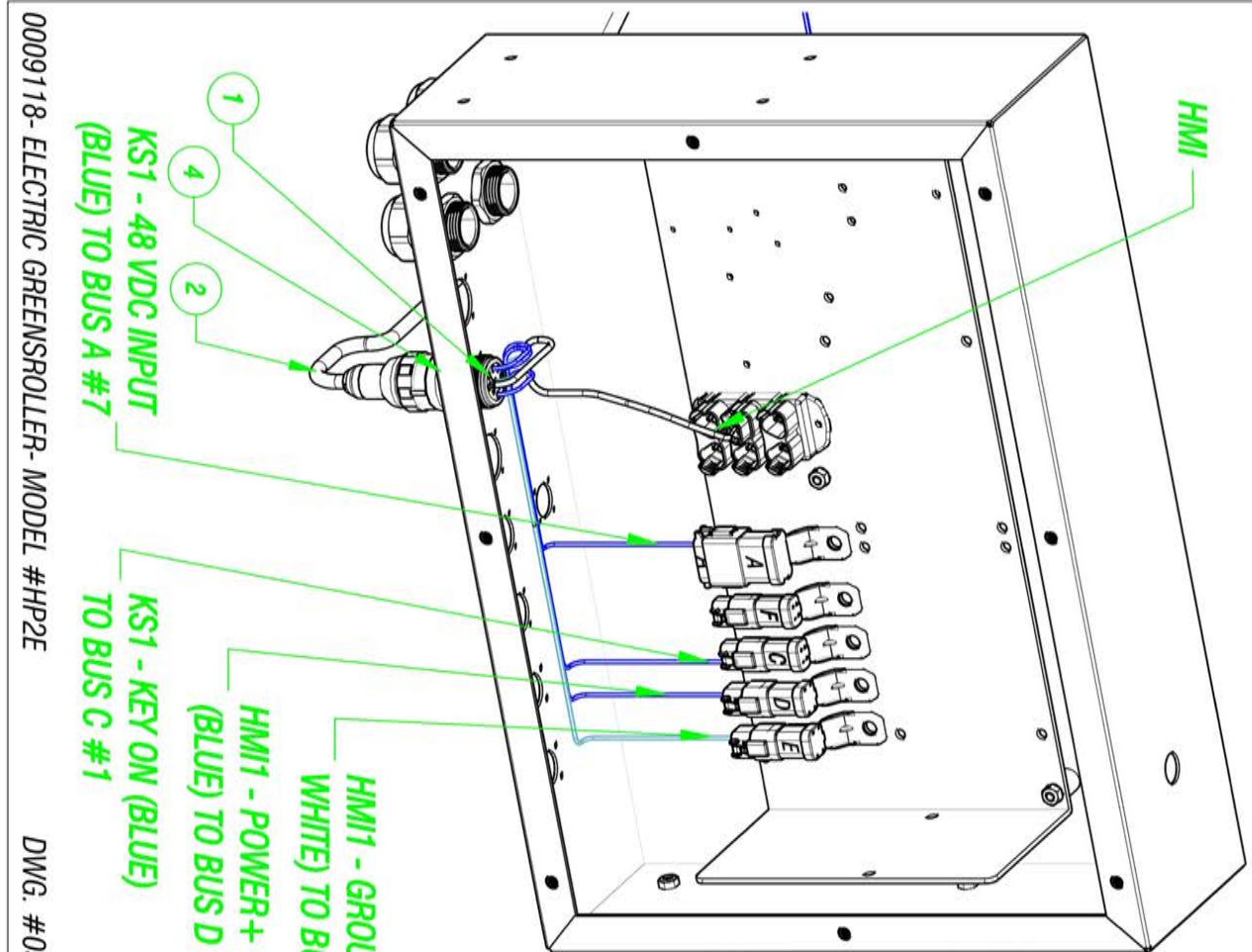

HMI

1
4
2

**KS1 - 48 VDC INPUT
(BLUE) TO BUS A #7**

**KS1 - KEY ON (BLUE)
TO BUS C #1**

**HMI1 - GROUND- (BLUE/
WHITE) TO BUS E #6**

**HMI1 - POWER+ 12 VDC
(BLUE) TO BUS D #6**

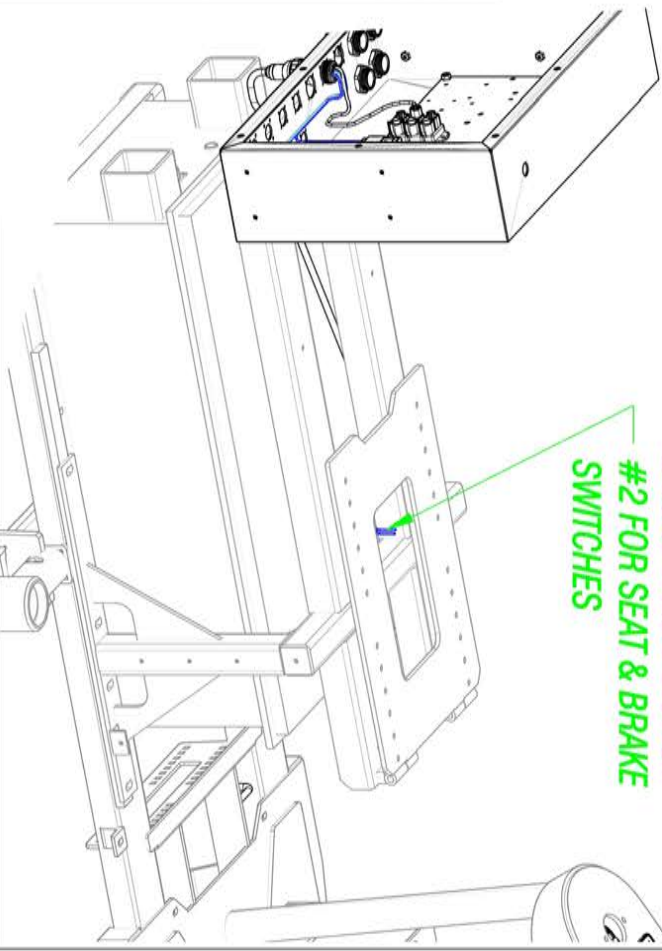

**LOOSE WIRES ON ITEM
#2 FOR SEAT & BRAKE
SWITCHES**

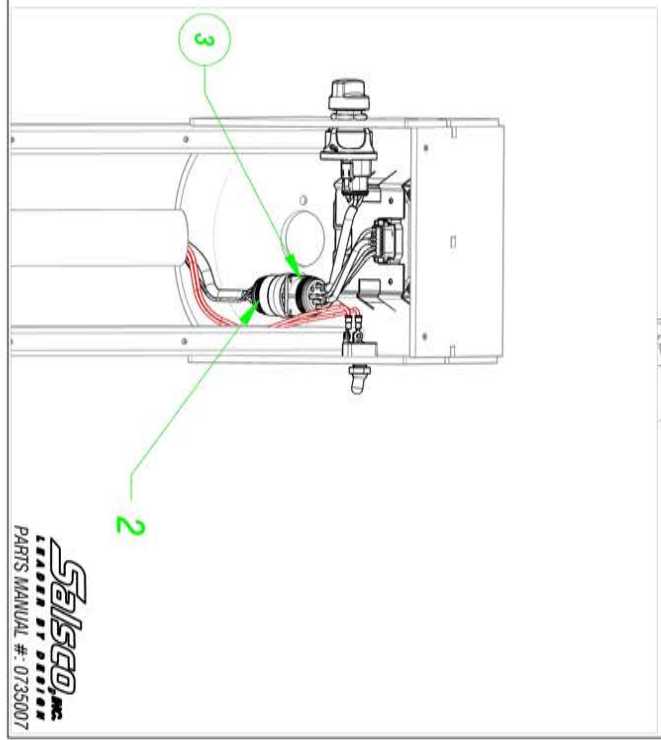

3
2

0009118- ELECTRIC GREENSROLLER- MODEL #HP2E

DWG. #05N



ITEM	DESCRIPTION	PART NO.	QTY
1	WIRE HARNESS, EXTERNAL POWER ASSY. - #HA68121-5325	0315619	1
2	WIRE - 18GA. BLACK - 28" LG. - 1/4" RING TERMINAL TO FEMALE PIN (BUS E SOCKET #1 TO BUS BAR)	0315636	1

REVISIONS	
ISSUE DATE:	DESCRIPTION OF CHANGE/EFFECTIVE DATE OF CHANGE:
11/11/24	FIRST ISSUANCE OF PARTS MANUAL XX/XX/XX

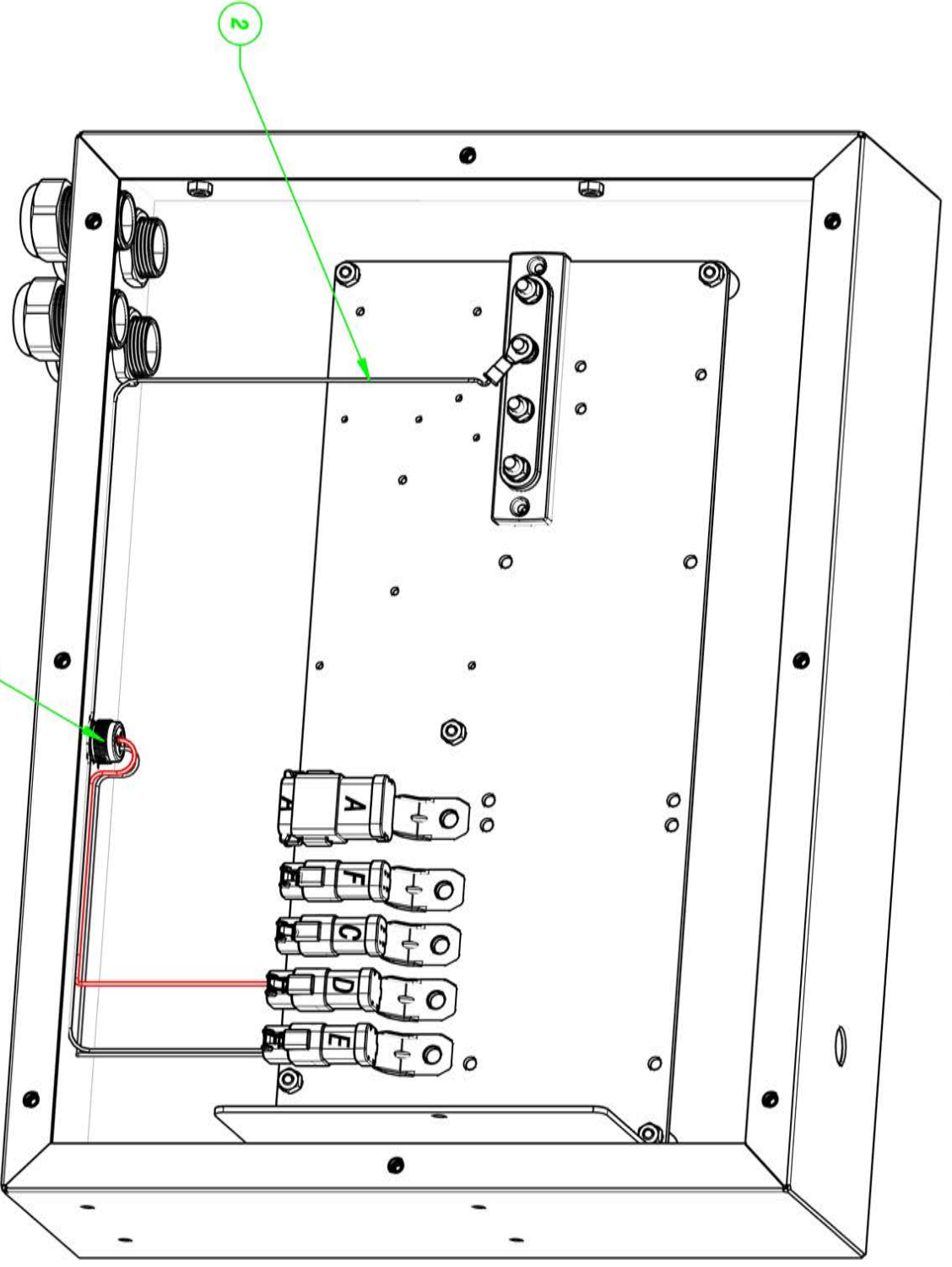

0009118- ELECTRIC GREENROLLER- MODEL #HP2E

DWG. #05P

DESCRIPTION
WIRE CONNECTIONS FOR EXTERNAL POWER HARNESS & GROUND WIRE.



DESCRIPTION
WIRE CONNECTIONS FOR L.E.D. LIGHTS & SWITCH

REVISIONS
ISSUE DATE: 11/11/24
DESCRIPTION OF CHANGE/EFFECTIVE DATE OF CHANGE: FIRST ISSUANCE OF PARTS MANUAL
XXXXXX

RED WIRES TO BE SPliced TOGETHER, FED INTO CHARGER BOX, THEN JOIN RED FUSED WIRE ON VOLTAGE REGULATOR

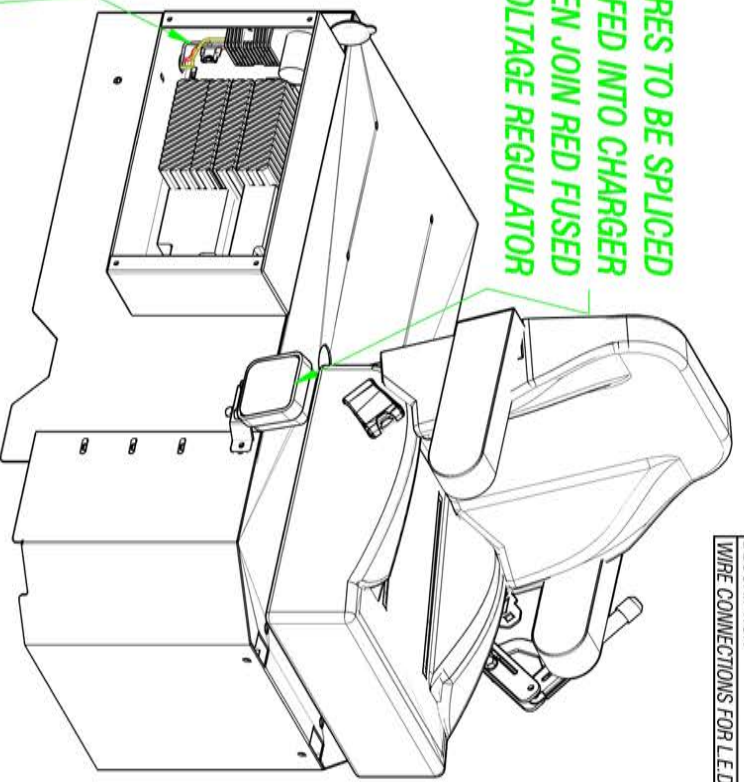

BLACK WIRES TO BE SPliced TOGETHER, SPliced w/ BLACK L.E.D. WIRES, THEN CONNECTED TO NEGATIVE TERMINAL ON BATTERY

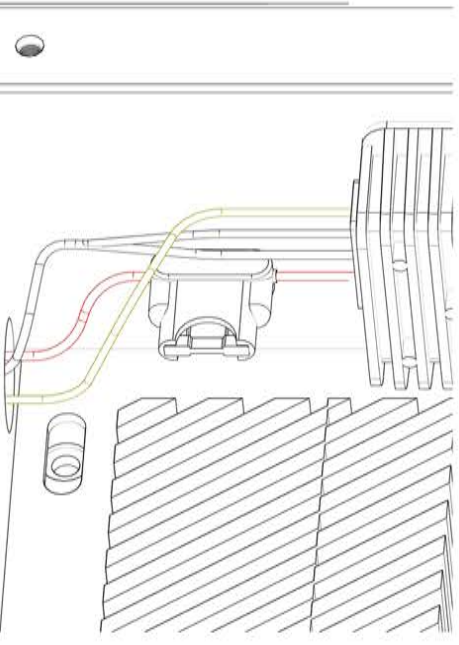

TO YELLOW WIRE ON VOLTAGE REGULATOR

THIS WIRE TO BE SPliced TO RED L.E.D. WIRES, THEN TO RED FUSED WIRE ON VOLTAGE REGULATOR

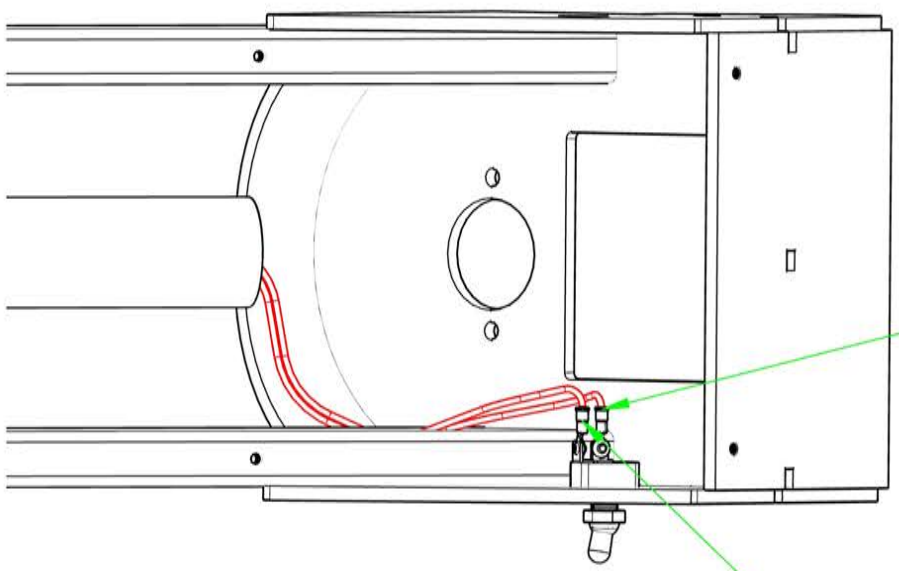

0009118- ELECTRIC GREENROLLER- MODEL #HP2E

DWG. #05Q



ITEM	DESCRIPTION	PART NO.	QTY
1	PANEL, BATTERY ENCLOSURE - TOP	0489455	1
2	PANEL, BATTERY ENCLOSURE - FRONT	0489456	1
3	PANEL, BATTERY ENCLOSURE - LEFT	0489458	1
4	PANEL, BATTERY ENCLOSURE - RIGHT	0489459	1

REVISIONS	
ISSUE DATE:	DESCRIPTION OF CHANGE/ EFFECTIVE DATE OF CHANGE:
11/11/24	FIRST ISSUANCE OF PARTS MANUAL. XXXXXX

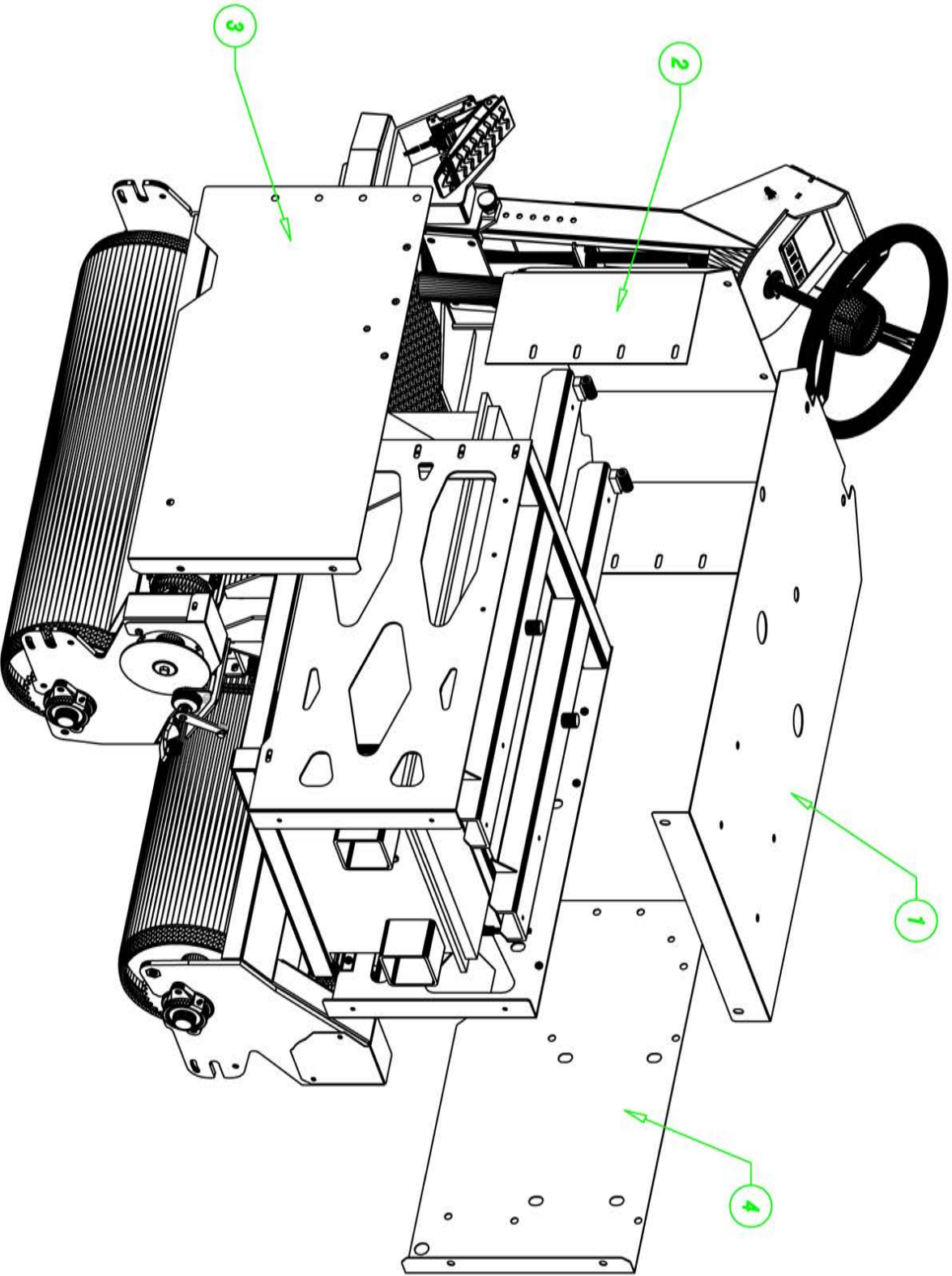

0009118- ELECTRIC GREENSROLLER- MODEL #HP2E

DWG. #06

ITEM	DESCRIPTION	PART NO.	QTY
1	BATTERY- 51.2V LITHIUM	0315498	1
2	PANEL, BATTERY ENCLOSURE MOUNTING- LEFT	0289462	1
3	PANEL, BATTERY ENCLOSURE MOUNTING- RIGHT	0289464	1
4	FRAME, SEAT MOUNTING	0219650	1
5	D.O.M. TUBE- 05/8" O.D. x .120" WALL x 11 1/8" LG.	RAW MATL	2
6	THREADED ROD- 3/8-16 x 14 3/4" LG.	RAW MATL	2

REVISIONS		
ISSUE DATE	DESCRIPTION OF CHANGE	EFFECTIVE DATE OF CHANGE
11/1/24	FIRST ISSUANCE OF PARTS MANUAL	XXXXXX

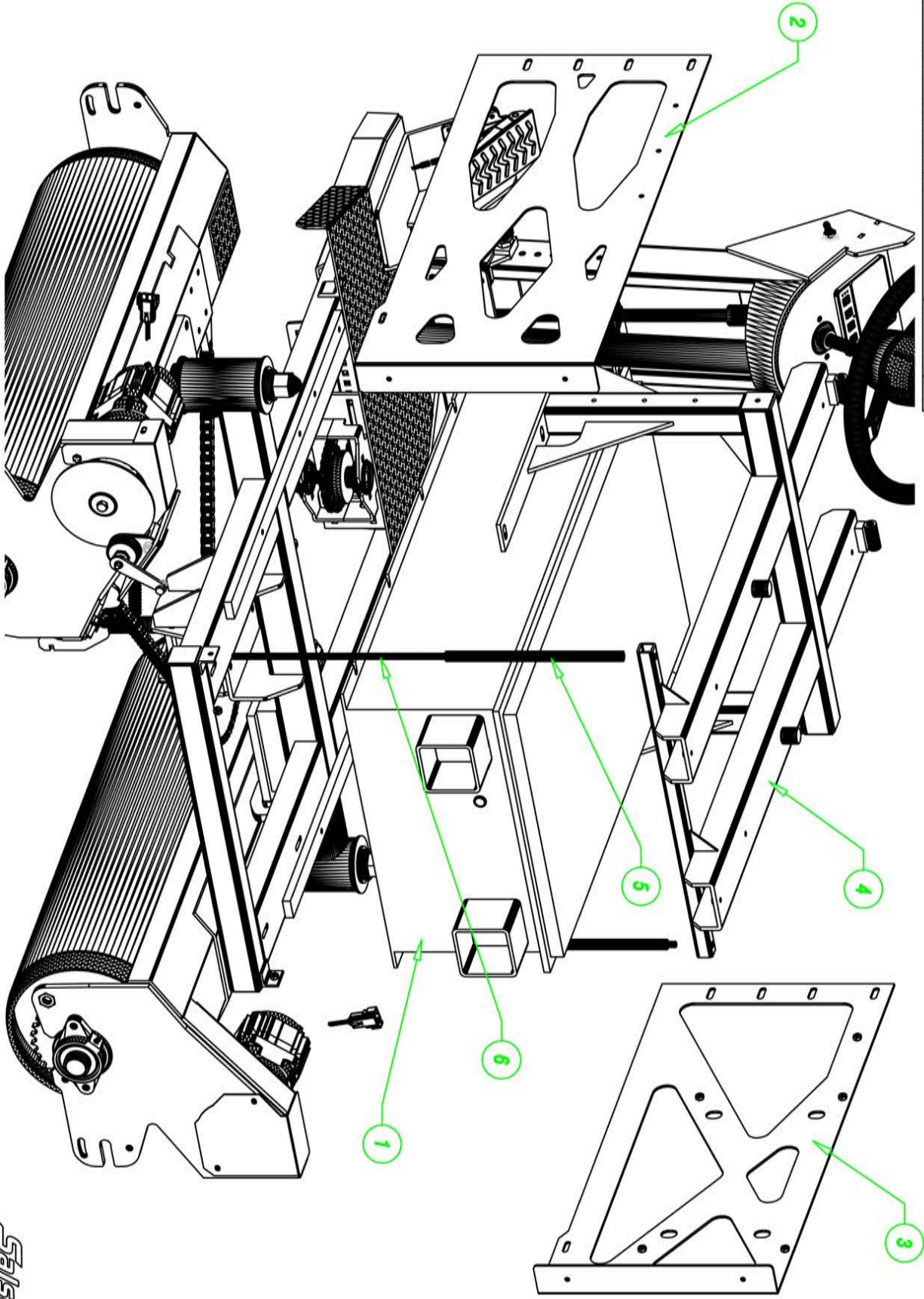

0009118- ELECTRIC GREENROLLER- MODEL #HP2E

DWG. #07

Salsgo
LEADER BY DESIGN
PARTS MANUAL #: 0735007

ITEM	DESCRIPTION	PART NO.	QTY
1	PANEL, STEERING COLUMN- FRONT	0489454	1
2	DISPLAY PANEL	0315507	1
3	DISPLAY PANEL MOUNTING BRACKET	0315508	1
4	KEYSWITCH	0315511	1
5	TOGGLE SWITCH	0315143	1
6	TOGGLE SWITCH BOOT	0315145	1
7	TOGGLE SWITCH ON/ OFF TAG	0315155	1

REVISIONS		
ISSUE DATE	DESCRIPTION OF CHANGE/EFFECTIVE DATE OF CHANGE	XXXXXX
11/11/24	FIRST ISSUANCE OF PARTS MANUAL	

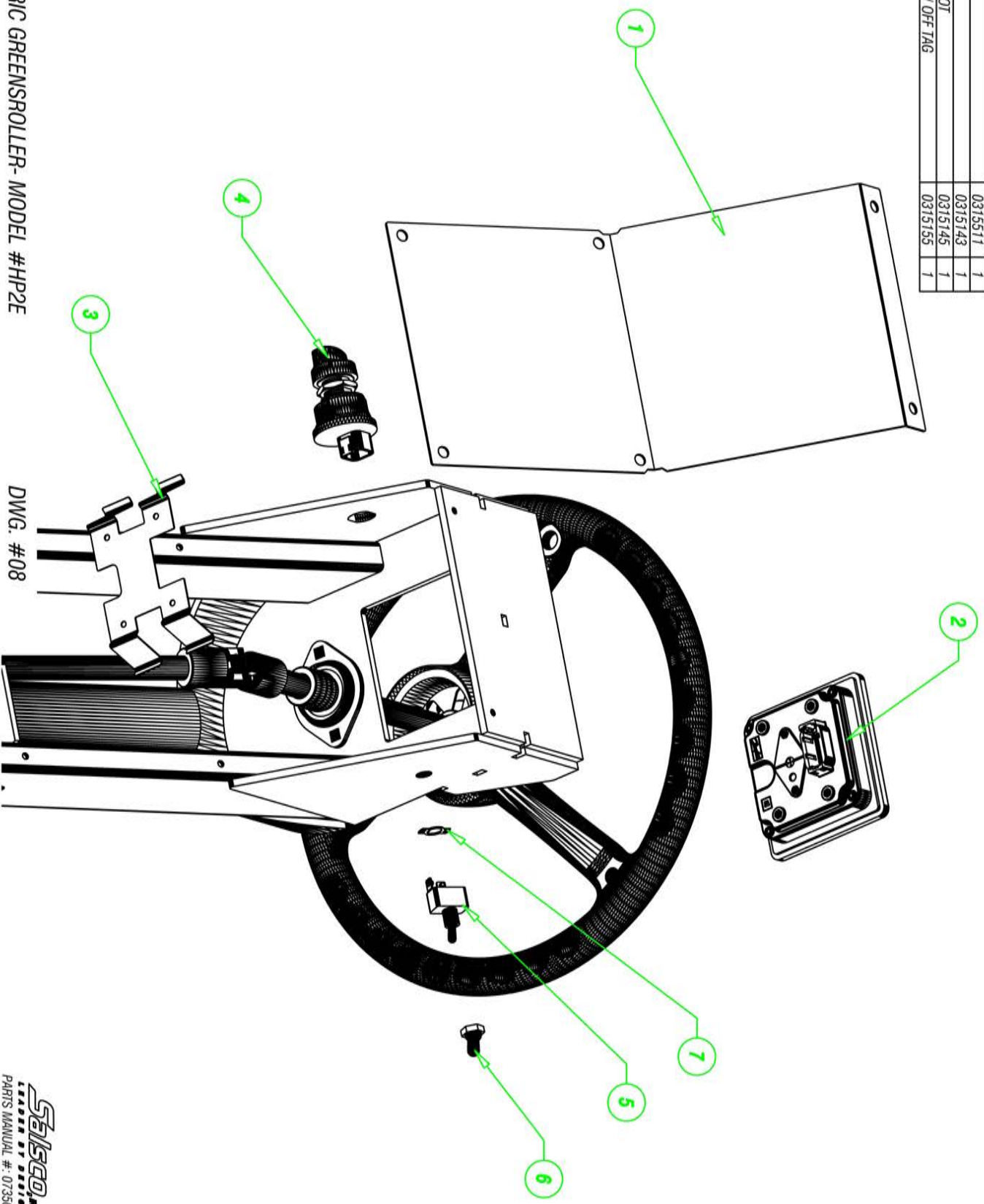

0009118- ELECTRIC GREENROLLER- MODEL #HP2E

DWG. #08



ITEM	DESCRIPTION	PART NO.	QTY
1	SHAFT, STEERING	0248473	1
2	WHEEL, STEERING	0354142	1
3	STEERING WHEEL CAP	0354143	1
4	BEARING FLANGETTE- 2-BOLT FOR 03/4" BEARING INSERT	0303005	2
5	BEARING INSERT- FLANGETTE TYPE- 03/4" BORE	0303023	2
6	COLLAR, SET- 03/4" BORE	0311006	2

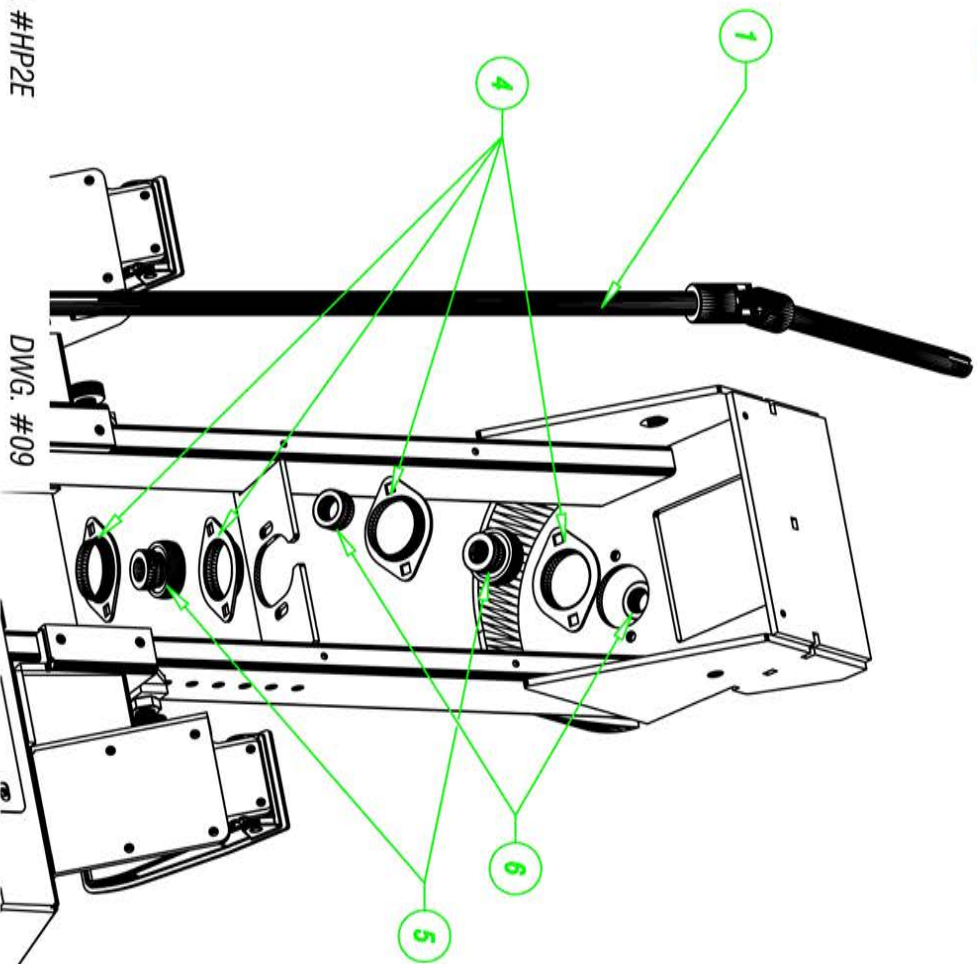
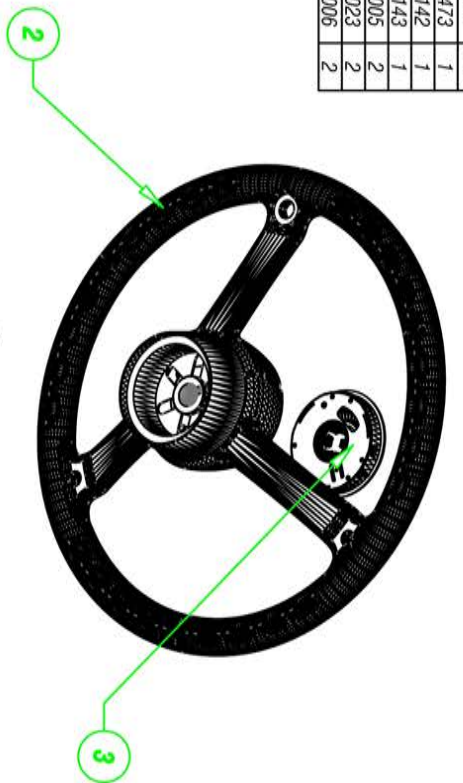

REVISIONS		
ISSUE DATE	DESCRIPTION OF CHANGE/ EFFECTIVE DATE OF CHANGE	XXXXXX
11/11/24	FIRST ISSUANCE OF PARTS MANUAL	

0009118- ELECTRIC GREENROLLER- MODEL #HP2E

DWG. #09

ITEM	DESCRIPTION	PART NO.	QTY
1	BASE, ADJUSTABLE HEIGHT PEDAL- LEFT	0284128	1
2	BASE, ADJUSTABLE HEIGHT PEDAL- RIGHT	0284129	1
3	PEDAL FOOT	0315506	2
4	PIN, RETRACTABLE SPRING PLUNGER	0340256	2
5	SLEEVE, FOOT PEDAL SLIDE	0429122	2
6	PLATE, PEDAL BASE ATTACHMENT	0492250	2
7	PLATE, HP2E FRAME DECK	0492249	1

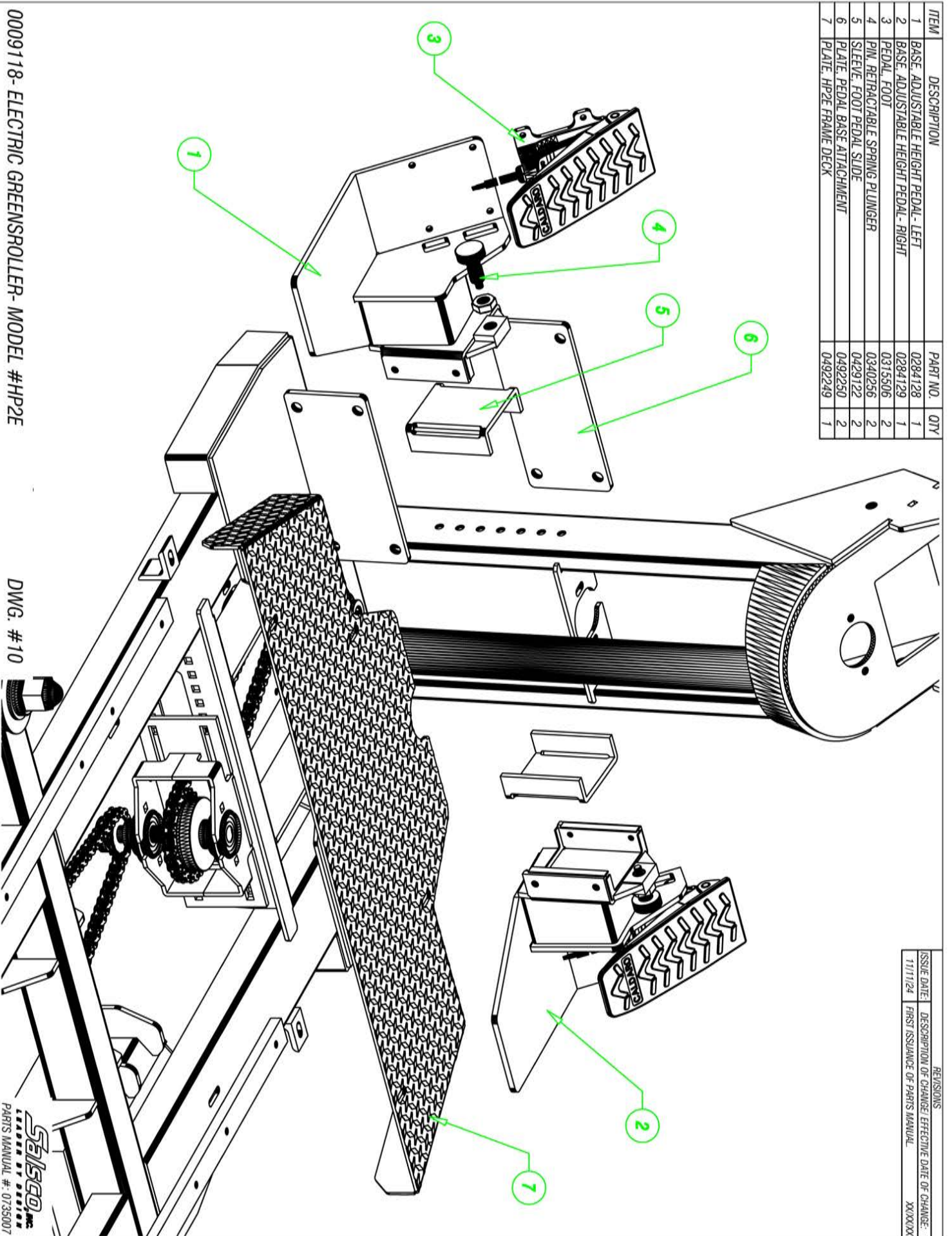

REVISIONS	
ISSUE DATE:	DESCRIPTION OF CHANGE/ EFFECTIVE DATE OF CHANGE:
11/11/24	FIRST ISSUANCE OF PARTS MANUAL XXXXXX

0009118- ELECTRIC GREENROLLER- MODEL #HP2E

DWG. #10

Stiga
 A DIVISION OF STIGA
 PARTS MANUAL # 0735007

ISSUE DATE	DESCRIPTION OF CHANGE	EFFECTIVE DATE OF CHANGE
11/1/24	FIRST ISSUANCE OF PARTS MANUAL	XXXXXX

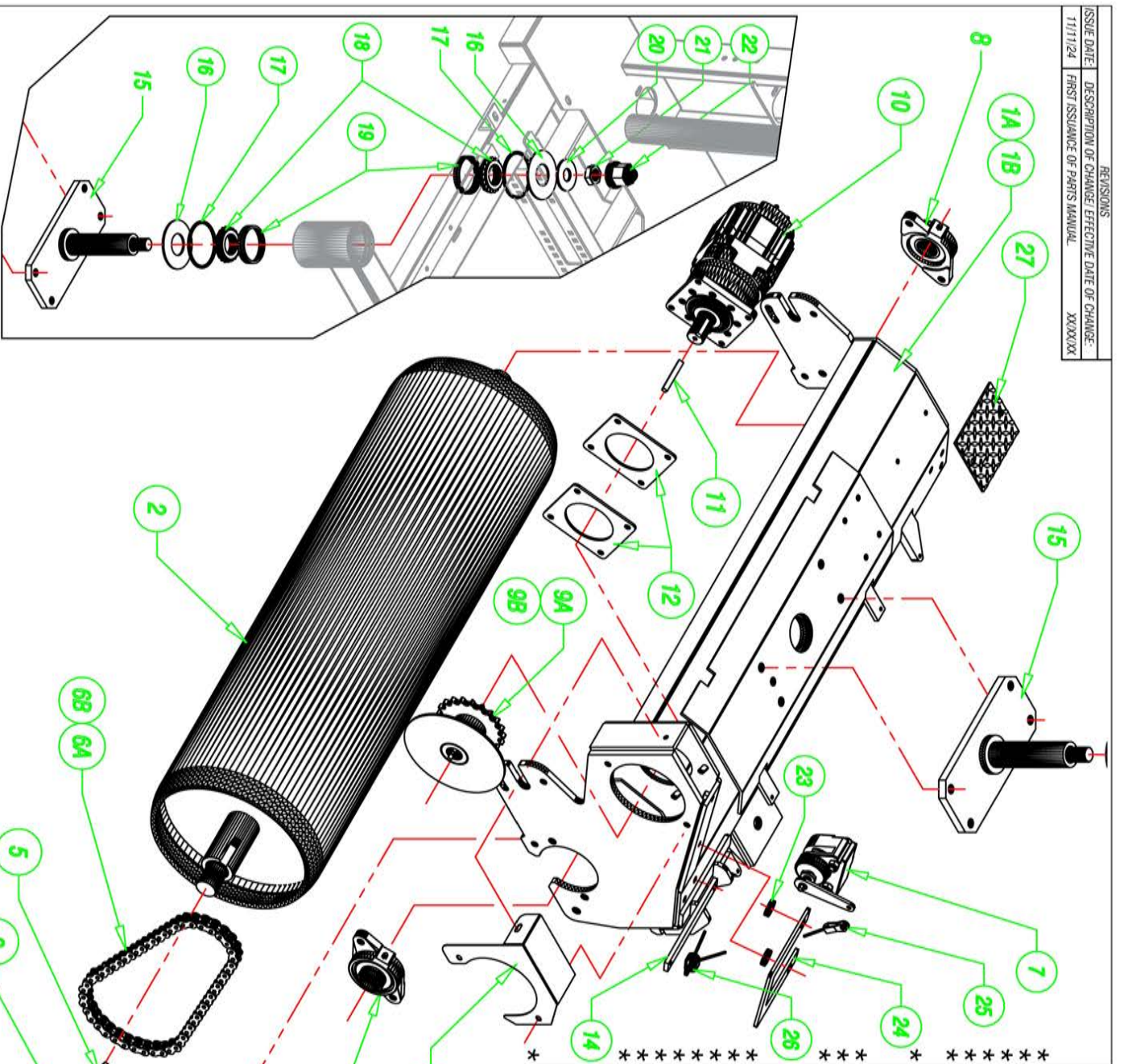

ITEM	DESCRIPTION	PART NO.	QTY
1A	HOUSING, ROLL- LEFT	0228387	1
1B	HOUSING, ROLL- RIGHT (NOT SHOWN)	0228388	1
2	SHAFT, ROLLER	0248320	2
3	TAPER LOCK BUSHING- TYPE 2012-2* (INCLUDES KEY)	0351213	2
4	SPROCKET, TAPER LOCK- #5081B32	0351212	2
5	KEY, SQUARE- 1/2" x 1/2" x 1 1/4" LG.	RAW MATL	2
6A	CHAIN- #50 x 59 PITCHES	0309051	2
6B	CHAIN LINK- #50 STANDARD CONNECTING LINK	0309008	2
7	BRAKE CALPER ASSY.	0336126	1
8	BEARING, 2-BOLT FLANGE STYLE- 01 1/4" BORE	0303083	4
9A	SPROCKET, DRIVE MOTOR & EMERGENCY BRAKE	0251295	1
9B	SPROCKET, ROLLER SHAFT DRIVE (NOT SHOWN)	0251292	1
10	ELECTRIC DRIVE MOTOR	0315503	2
11	KEY, SQUARE- 8mm x 8mm x 58mm LG.	RAW MATL	2
12	SPACER, DRIVE MOTOR BOSS	0449403	4
13A	GUARD, ROLLER SHAFT DRIVE CHAIN- LEFT	0421797	1
13B	GUARD, ROLLER SHAFT DRIVE CHAIN- RIGHT (NOT SHOWN)	0421630	1
14	BAR, EMERGENCY BRAKE CABLE MOUNTING	0470189	1
15	SHAFT, ROLL HOUSING PIVOT	0248392	2
16	SPACER- 11GA. x 1 9/16" I.D. x 3 1/2" O.D.	0453117	4
17	O-RING- 03" I.D. x 3 3/8" O.D. x 3/16"	0343003	4
18	BEARING, BEARING- CONE (TAPERED)- 01 1/2" BORE	0303089	4
19	BEARING, BEARING- CUP (TAPERED)- 01 1/2" BORE	0303090	4
20	WASHER- FLAT- 07/8" U.S.S.	0353145	2
21	NUT, HEX JAM- 7/8-14	0338060	2
22	NUT, LUG CAP	0338405	2
23	D.O.M. TUBE- 01" O.D. x 3/8" I.D. x 260" LG.	RAW MATL	2
24	PLATE, EMERGENCY BRAKE CALPER MOUNTING	0492220	1
25	CABLE, EMERGENCY BRAKE	0408053	1
26	CLAMP, DOUBLE TUBE "P"- SHAPED- 07/16" I.D.	0310132	1
27	PLATE, FOOT STEP	0490534	2

*HALF OF THE QUANTITIES SHOWN FOR THESE ITEMS ARE USED ON RIGHT SIDE OF MACHINE.

*****13B ON RIGHT SIDE OF MACHINE IS MIRRORED APPEARANCE, W/ NO CUTOFF FOR BRAKE DISC.**

0009118- ELECTRIC GREENROLLER- MODEL #HP2E

DWG. #11



ITEM	DESCRIPTION	PART NO.	QTY
1	ROD, STEERING TIE-SUB-ASSY	0145271	1
1A	ROD, STEERING TIE	0245272	1
1B	BALL JOINT ROD END- 1/2-20 RIGHT-HAND THREADED FEMALE SHANK w/ 1/2-20 RIGHT-HAND THREADED STUD	0303017	2
1C	NUT, HEX JAM- 1/2-20	0338038	2
2A	ROLLER CHAIN- #40 x 70 PITCHES	BULK	1
2B	CONNECTING (MASTER) LINK, STANDARD- #40 CHAIN	0309006	1
3A	ROLLER CHAIN- #40 x 108 PITCHES	BULK	1
3B	CONNECTING (MASTER) LINK, STANDARD- #40 CHAIN	0309006	1
4	ROLLER CHAIN- #50 x 69 PITCHES	BULK	1
5	SPRING, EXTENSION- .0314" O.D. x .093" WIRE x 3 1/2" FREE LENGTH	0350009	2

* ITEM # 1 CONTAINS THESE INDIVIDUAL PARTS

ISSUE DATE	DESCRIPTION OF CHANGE	EFFECTIVE DATE OF CHANGE
11/1/24	FIRST ISSUANCE OF PARTS MANUAL	XXXXXX

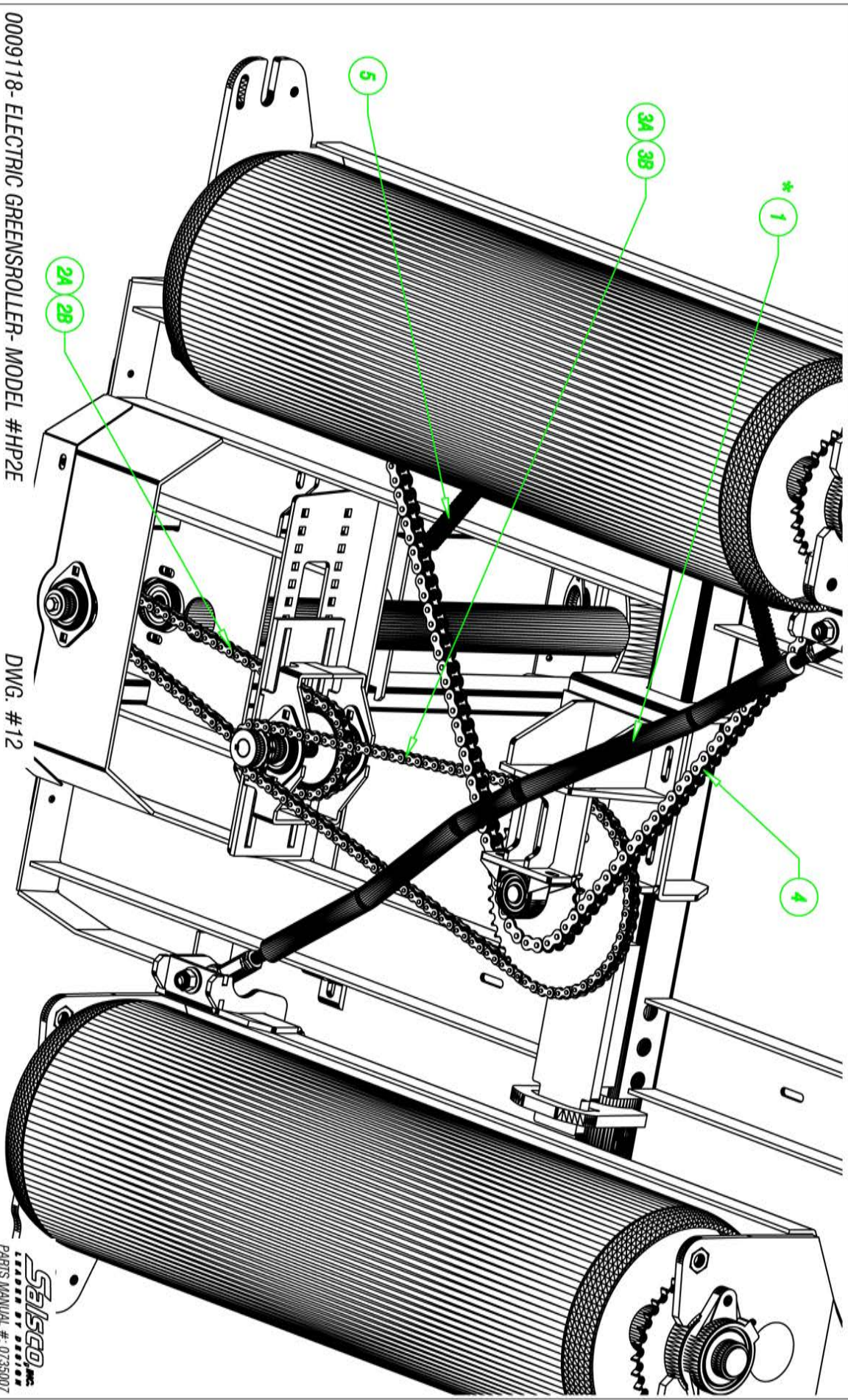

0009118- ELECTRIC GREENSROLLER- MODEL #HP2E

DWG. #12

5E1500
LEADER OF DESIGN
PARTS MANUAL # 0735007

ITEM	DESCRIPTION	PART NO.	QTY
1	GUARD, STEERING COLUMN, LOWER FRONT	0221809	1
2	BEARING FLANGETTE, 2-BOLT FOR 03/4" BEARING INSERT	0303005	4
3	BEARING INSERT, FLANGETTE TYPE, 03/4" BORE	0303023	6
4	SPROCKET #40BS12 X 03/4" BORE W/ KEWAY & SETSCREWS	0351018	2
5	WASHER, FLAT, 3/8" S.A.E.	0353102	1
6	HEX HEAD CAP SCREW, 5/16-18 X 1" LG. (GRADE 8)	0346173	1
7	SPROCKET #40BS24 X 03/4" BORE W/ KEWAY & SETSCREWS	0351187	1
8	BRACKET, STEERING REDUCTION	0206982	1
9	SHAFT, STEERING REDUCTION	0448475	1
10	BOX, STEERING PIVOT SHAFT MOUNTING	0280096	1
11	SPROCKET/ SHAFT, STEERING REDUCTION	0251060	1
12	BEARING PILLOW BLOCK FLANGETTE, 2-BOLT FOR 03/4" BEARING INSERT	0303024	2

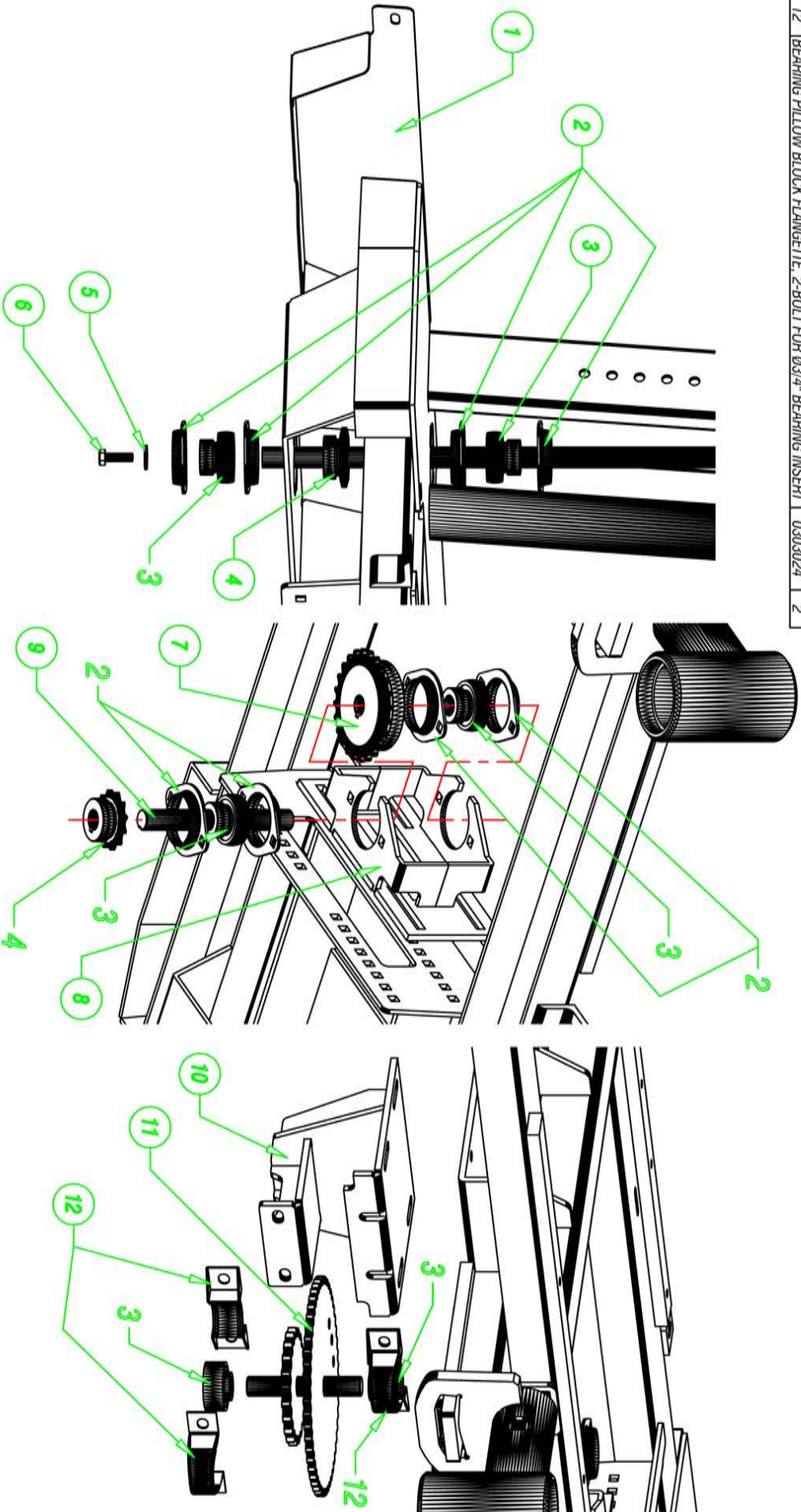

REVISIONS		
ISSUE DATE	DESCRIPTION OF CHANGE / EFFECTIVE DATE OF CHANGE	XXXXXX
11/11/24	FIRST ISSUANCE OF PARTS MANUAL	

0009118- ELECTRIC GREENSROLLER- MODEL #HP2E

DWG. #13

ITEM	DESCRIPTION	PART NO.	QTY
1	FRAME, BASE	0219649	1
2	HOUSING, OSCILLATION LIMITING	0228389	1

REVISIONS			
ISSUE DATE	DESCRIPTION OF CHANGE/ EFFECTIVE DATE OF CHANGE:	ISSUE DATE	DESCRIPTION OF CHANGE/ EFFECTIVE DATE OF CHANGE:
11/11/24	FIRST ISSUANCE OF PARTS MANUAL	XXXXXX	

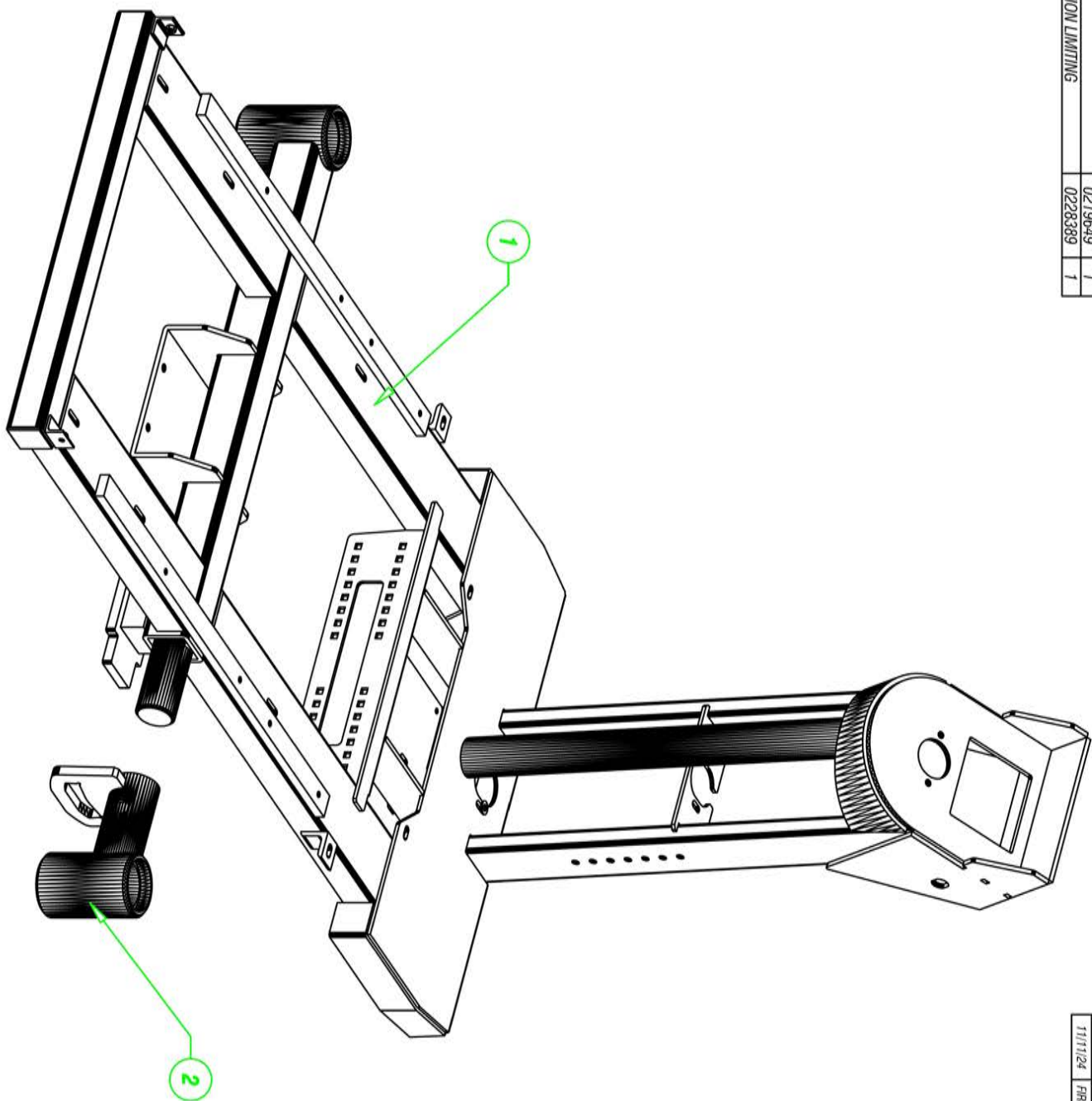

0009118- ELECTRIC GREENSROLLER- MODEL #HP2E

DWG. #14

Seisgo, Inc.
LEADER BY DESIGN
PARTS MANUAL #: 0735007



Salsco, INC.
LEADER BY DESIGN

Revised on 2_19_2025.