



How to Use This Manual

This manual provides detailed instructions on installation and maintenance of gear drives and couplings. Use the table of contents below to locate required information.

CAREFULLY FOLLOW THE INSTRUCTIONS IN THIS MANUAL FOR OPTIMUM PERFORMANCE AND TROUBLE FREE SERVICE.

Table of Contents

Installation Instructions Page 1
Mounting Positions Page 2
Tightening Torques Page 2
Shaft Connections. Page 3
Lubrication Recommendations Page 4
Preventive Maintenance. Page 5
Stored and Inactive Gear Drives. Page 5
Lube Quantities for Incline Mtg., Sizes 03 & 04 Page 6
Lube Quantities for Incline Mtg., Sizes 06 & 07 Page 7
Lube Quantities for Incline Mtg., Sizes 08, 09, 10, 12, & 14 Page 8

Introduction

Credit for long service and dependable operation of a gear drive is often given to the engineers who designed it, or the craftsmen who constructed it, or the sales engineer who recommended the type and size. Ultimate credit belongs to the mechanic on the job who worked to make the foundation rigid and level, who accurately aligned the shafts and carefully installed the accessories, and who made sure that the drive received lubrication at prescribed intervals.. The details of this important job are the subject of this manual.

NAMEPLATE — Operate Rexnord gear drives only at horsepower, speed and ratio shown on nameplate and in the mounting position for which it was ordered. Before changing any one of these, submit complete nameplate data and new application conditions to the Factory for correct oil level, parts and application approval.

WARNING: Consult applicable local and national safety codes for proper guarding of rotating members. Lock out power source and remove all external loads from drive before servicing drive or accessories.

Warranty

Rexnord Industries, LLC (the "Company") warrants that Ultramite gear drives (I) conform to Company's published specifications, and (II) are free from defects of material for three years from the date of shipment.

Company does not warrant any non-Company branded products or components (manufacturer's warranty applies) or any defects in, damage to, or failure of products caused by: (I) dynamic vibrations imposed by the drive system in which such products are installed unless the nature of such vibrations has been defined and accepted in writing by Company as a condition of operation; (II) failure to provide suitable installation environment; (III) use for purposes other than those for which designed, or other abuse or misuse; (IV) unauthorized attachments, modifications or disassembly, or (V) mishandling during shipping.

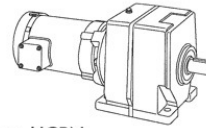

Type UCBN

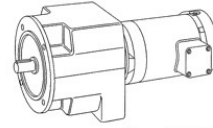

Type UCFN

Installation Instructions

The following instructions apply to standard Falk Type UCBN (base mounted) and UCFN (flange mounted) drives shown above. If a drive is furnished with special features, refer to the supplementary instructions shipped with the drive.

WELDING — Do not weld on the gear drive or accessories without prior approval from the Factory. Welding on the drive may cause distortion of the housing or damage to the bearings and gear teeth. Welding without prior approval could void the warranty.

EFFECTS OF SOLAR ENERGY — If the gear drive operates in the sun at ambient temperatures over 100°F(38°C), then special measures should be taken to protect the drive from solar energy. This protection can consist of a canopy over the drive or reflective paint on the drive. If neither is possible, consult the Factory.

MOUNTING (Figure 1, Page 2) — Sizes 03 and 04 are lubricated for life and will be furnished filled with an EP (extreme pressure) mineral lubricant to the appropriate level determined by the mounting position ordered. Synthetic EP lubricants will be furnished upon request at an extra charge. Sizes 06 thru 14 are furnished without oil. Refer to Table 3, Page 4 for a list of typical lubricants meeting Rexnord specifications. Fill drives to the oil level plug. Refer to Table 4, Page 5 for the approximate quantities of oil by the drive mounting position. Refer to Figure 1, Page 2 for the placement of the vent, drain and oil level plugs based on the drive mounting position.

FOUNDATION GENERAL — To facilitate oil drainage, elevate the gear drive foundation above the surrounding floor level. If desired, replace the drive oil drain plug with a valve, but provide a guard to protect the valve from accidental opening or breakage.

FOUNDATION, STEEL — When mounting gear drive on structural steel, it is recommended that an engineered design be utilized for a pedestal, adapter base or bed to provide sufficient rigidity, to prevent induced loads from distorting the housing and causing gear misalignment. In the absence of an engineered design, it is recommended that a base plate, with thickness equal to or greater than the thickness of the drive feet, be securely bolted to steel supports and extend under the entire drive.

FOUNDATION, CONCRETE — If a concrete foundation is used, allow the concrete to set firmly before bolting down the gear drive. For the best type of mounting, grout structural steel mounting pads into the mounting base, as illustrated, rather than grouting the drive directly into the concrete.

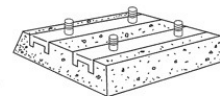

Motors and other components mounted on motor plates may become misaligned during shipment. ALWAYS check alignment after installation.

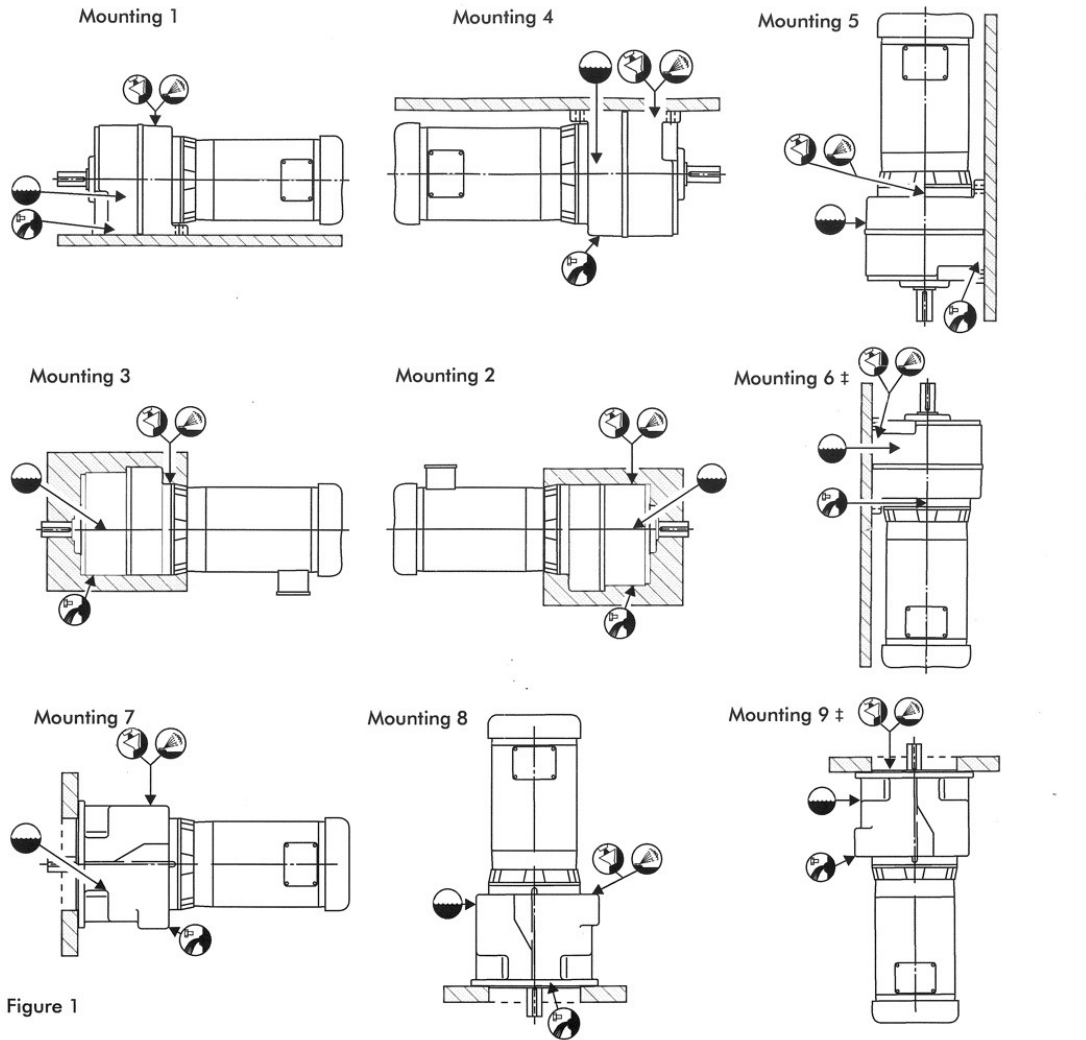

Figure 1

- = BREATHER
- = OIL DRAIN
- = OIL FILL
- = OIL LEVEL

‡ Use motor fitted with a seal.

Fastener Tightening Torques

Use the tightening torque values specified in Table 1, for fastening gear drives, motors, and accessories to their mounting surfaces with non-lubricated fasteners. DO NOT use these values for "torque locking" fasteners or for fastening components with aluminum feet or with soft gaskets or vibration dampers on the mounting surface. If the tightening torque exceeds the capacity of the torque wrench, use a torque multiplier. Use Grade 5 fasteners for diameters through 1.50".

Table 1 — Tightening Torques (lb-in) ±5%
DO NOT Lubricate Fasteners

Thread Dia – UNC	Metal to Metal	Metal to Concrete
.250-20	90	70
.3125-18	185	145
.375-16	330	255
.500-13	825	640
.625-11	1440	1280
.750-10	2940	2290

288-101

January 2007
Supersedes 11-02

Rexnord Industries, LLC, 3001 W. Canal St., Milwaukee, WI 53208-4200
Telephone: 414-342-3131 Fax: 414-937-4359
e-mail: info@rexnord.com web: www.rexnord.com

GEAR DRIVE ALIGNMENT — Align drive with driven equipment by placing broad, flat shims under all mounting pads. Start at the low speed shaft end and level across the length and then the width of the drive. Check with a feeler gauge to make certain that all pads are supported to prevent distortion of housing when drive is bolted down. After drive is aligned with driven equipment and bolted down, align prime mover to drive input shaft. Refer to next column for coupling alignment.

Check high speed shaft coupling alignment. If the coupling is misaligned, the drive is shimmed incorrectly. Re-shim drive and recheck high speed coupling alignment. If necessary, realign motor.

Shaft Connections

WARNING: Provide suitable guards in accordance with OSHA standards.

Input and output shaft extension diameter tolerance is +.0000"; -.0005" for shafts up to 1.375" diameter and +.000"; -.001" for shafts larger than 1.375" diameter. The fitted component must be machined to ensure proper fit.

DO NOT drive coupling hub, pinion, sprocket or pulley on the shaft. An endwise blow on the shaft may damage gears and bearings. Coupling hubs, pinions, sprockets or pulleys must be pushed onto the shaft using a screw jack device fitted into the threaded hole provided in the end of the shaft, see Table 2 below.

Table 2 — Shaft End Threaded Holes – Inches

DRIVE SIZE	Input Shaft	Output Shaft
03	.250 x .500 UNF	.250 x .630 UNF
04	.250 x .500 UNF	.250 x .630 UNF
06	.250 x .630 UNF	.375 x .870 UNF
07	.312 x .630 UNF	.625 x 1.42 UNF
08	.312 x .870 UNF	.625 x 1.42 UNF
09	.500 x 1.10 UNF	.750 x 1.65 UNF
10	.625 x 1.42 UNF	.750 x 1.65 UNF
12	.750 x 1.65 UNF	1.00 x 1.97 UNF
14	.750 x 1.65 UNF	1.00 x 1.97 UNF

COUPLING CONNECTIONS — The performance and life of any coupling depends largely upon how well the coupling is installed and serviced. Refer to the coupling manufacturer's manual for specific instructions.

CORRECT METHOD

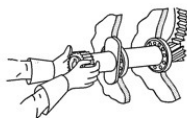

Heat interference fitted coupling hubs, pinions, sprockets or pulleys to a maximum of 275°F (135°C) and slide onto gear drive shaft.

INCORRECT METHOD

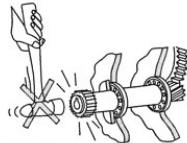

DO NOT drive coupling hub, pinion, sprocket or pulley onto the shaft. An endwise blow on the shaft/coupling may damage gears and bearings.

**– CAUTION –
DO NOT HAMMER**

FALK™ COUPLINGS — (Except fluid type) Detailed installation manuals are

available from the Factory, your local Rexnord Representative or Distributor—just provide size and type designations stamped on

the coupling. For lubricant requirements and a list of typical lubricants meeting Rexnord specifications, refer to appropriate coupling service manual.

GAP AND ANGULAR ALIGNMENT — If possible, after mounting coupling hubs, position the driving and driven equipment so that the distance between shaft ends is equal to the coupling gap. Align the shafts by placing a spacer block, equal in thickness to required gap, between hub faces, as shown, and also at 90° intervals around the hub. Check with feelers.

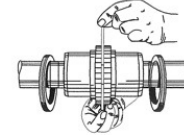

STEELEX® ILLUSTRATED

OFFSET ALIGNMENT — Align driving and driven shafts so that a straight edge will rest squarely on both couplings hubs as shown to the right and also at 90° intervals. Tighten foundation bolts of the connected equipment and recheck alignment and gap.

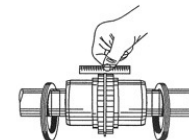

STEELEX ILLUSTRATED

SPROCKETS, PULLEYS OR SHEAVES — Mount power take-offs as close to the gear drive housing as possible to avoid undue bearing load and shaft deflection.

Align the output shaft of the gear drive square and parallel with the driven shaft by placing a straightedge across the face of the sprockets or sheaves as illustrated. Check horizontal shaft alignment by placing one leg of a square against the face of the sheave or sprocket with the spirit level on the horizontal leg of the square.

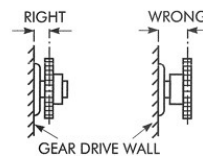

GEAR DRIVE WALL

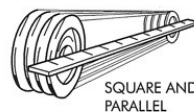

SQUARE AND PARALLEL

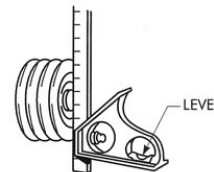

LEVEL

DO NOT over tighten belts or chains. Adjust chains to manufacturers' specifications. Adjust belts as follows:

The ideal tension is the lowest tension at which the belt will not slip under peak load conditions. Check the belt tension frequently during the first 24 to 48 hours of run-in operation. Over tightening belts shortens belt and bearing life. Keep belts free from foreign material which may cause slippage. Inspect the V-belts periodically; tighten the belts if they are slipping.

PINION MOUNTING — Mount pinion as close to the drive as possible to avoid undue bearing load and shaft deflection. Refer to the Factory for pinion alignment instructions.



Lubrication Recommendations

Carefully follow lubrication instructions on warning tags and installation manuals furnished with the gear drive. Nameplates are stamped with a designation for recommended lubricant, standard is 6E.

Lubricants listed in this manual are typical ONLY and should not be construed as exclusive recommendations. Refer to your lubricant supplier for additional lubricants meeting the indicated specifications. Industrial type extreme pressure (EP) gear lubricants are the recommended lubricants for ambient temperatures of 15°F to 125°F (-9°C to +52°C).

For drives operating outside the above temperature range refer to "Synthetic Lubricants" paragraphs. Synthetic lubricants can also be used in normal climates.

VISCOSITY (IMPORTANT) — The proper grades of EP Mineral Lubricants and EP Synthetic Lubricants are found in Table 3. For cold climates refer to "EP Synthetic Lubricant" paragraphs. Select a lubricant which has a pour point at least 10°F (5.5°C) below the expected minimum ambient starting temperature. Usable temperature ranges can sometimes be widened if specific application conditions are known.

Extreme Pressure (EP) Mineral Lubricants

Mineral (EP) Lubricants (Table 3) — Industrial type petroleum based extreme pressure lubricants are preferred. The EP lubricants currently recommended are of the sulfur-phosphorus type.

WARNING: EP LUBRICANTS IN FOOD PROCESSING INDUSTRY — EP lubricants may contain toxic substances and should not be used in the food processing industry without the lubricant manufacturers' approval. Lubricants which meet USDA "H1" classification are suitable for food processing applications.

Extreme Pressure (EP) Synthetic Lubricants

Synthetic (EP) Lubricants (Table 3) — Polyalphaolefin type extreme pressure lubricants are recommended for cold climate operation, high temperature applications, extended temperature range (all season) operation and/or extended lubricant change intervals.

WARNING: SYNTHETIC LUBRICANTS IN FOOD PROCESSING INDUSTRY — Synthetic lubricants may contain toxic substances and should not be used in the food processing industry without the lubricant manufacturers' approval. Lubricants which meet USDA "H1" classification are suitable for food processing applications.

Table 3 — Typical Lubricants Recommendations & Specifications

Mineral Lubricants Extreme Pressure		AGMA Viscosity Grade				
		5EP	6EP	7EP
		ISO Viscosity Grade				
		220	320	460
		Nameplate Designation				
		5E	6E	7E
		Ambient Temperature Range °F				
Manufacturer	Lubricant	+23 to +77	+32 to +104	+50 to +122
Chevron USA Inc.	Gear Compounds EP	220	320	460
Exxon Co. USA	Spartan EP	220	320	460
Mobil Oil Corp.	Mobilgear	630	632	634
Shell Oil Co.	Omala Oil	220	320	460

Synthetic Lubricants † Extreme Pressure (Except where noted) ‡		AGMA Viscosity Grade				
		05	25	55	65	75
		ISO Viscosity Grade				
		32	68	220	320	460
		Nameplate Designation				
		0H	2H	5H	6H	7H
		Ambient Temperature Range °F				
Manufacturer	Lubricant	-30 to +10	-15 to +50	+14 to +86	+32 to +113	+50 to +122
Canoco Inc.	Syncon	32 †	68	220
Exxon Co. USA	Spartan Synthetic EP	220	320	460
Mobil Oil Corp.	Mobilgear SHC	220	320	460
	Mobil SHC	624 †	626 †
Pennzoil Prod. Co.	Super Maxal "S"	...	68	220	320	460
Shell Oil Co.	Hyperia S	220	320	460
Sun Company Inc.	Sunoco Challenge EP	220	320	...
	Sunoco Challenge AC	32 †	68 †

‡ Consult lubricant supplier/manufacturer for maximum operating temperature.
 † Lubricant does not contain EP (extreme pressure) additives. Consult your lubricant supplier for additional lubricant recommendations.

Oil Levels

Sizes 03 and 04 are furnished filled with oil determined by the drive mounting position ordered and require no further lubrication. For inclined mounting, see Page 6 for lubricant quantities. Sizes 06 thru 14 oil levels are determined by drive mounting position. Location of the vent, drain and oil level plugs are determined by the drive mounting position and are shown in Figure 1, Page 2. Refer to Table 4, Page 5 for approximate quantities of oil by drive mounting position. For inclined mounting for Sizes 06 & 07, see Page 7 for lubricant quantities. Sizes 08, 09, 10, 12, & 14 see Page 8 for lubricant quantities.

Lubricant Changes (Sizes 06 – 14)

OIL ANALYSIS REPORT — Checking oil condition at regular intervals is recommended. In the absence of more specific limits, the guidelines listed below may be used to indicate when to change oil:

1. Water content is greater than 0.05% (500 ppm).
2. Iron content exceeds 150 ppm.
3. Silicon (dust/dirt) exceeds 25 ppm.
4. Viscosity changes more than 15%.

Sizes 06, 07, 08, 09, 10, 12, and 14 require an oil change at 2,500 hours for EP mineral lubricants and 10,000 for polyalphaolefin type EP synthetic lubricants.



Preventive Maintenance

AFTER FIRST WEEK — Check alignment of the total system and realign where necessary. Also, tighten all external bolts and plugs where necessary. DO NOT readjust the internal gear or bearing settings in the drive, these were permanently set at the Factory.

PERIODICALLY — Sizes 06 thru 14 Carefully check the oil level of the drive when it is stopped and at ambient temperature, add oil if needed. If the oil level is ABOVE the oil level plug have the oil analyzed for water content. If moisture content exceeds 500ppm change the oil. DO NOT fill above the oil level plug as leakage or undue heating may result. Also check coupling alignment to make certain that foundation settling has not caused excessive misalignment.

Stored & Inactive Gear Drives

Each gear drive is protected with rust preventive that will protect parts against rust for a period of 6 months in an indoor dry shelter.

Sizes 06 thru 14 — If a gear drive is to be stored, or is inactive after installation beyond the above periods, drain oil from housing and spray all internal parts with a rust preventive oil that is soluble in lubricating oil or add "Motorstor"™ vapor phase rust inhibitor at the rate of one ounce per cubic foot of internal drive space (or 5% of sump capacity) and rotate the shafts several times by hand. Before operating, drives which have been stored or inactive must be filled to the proper level with oil meeting the specifications given in this manual. Refer to Manual 128-014 for "Start-up after Storage" instructions.

Periodically inspect stored or inactive gear drives and spray or add rust inhibitor every six months, or more often if necessary. Indoor dry storage is recommended.

Gear drives ordered for extended storage can be treated at the Factory with a special preservative and sealed to rust-proof parts for periods longer than those cited previously.

Material Safety Data

Drives with nameplate designation 6E are filled with Mobilgear 632, drives with nameplate designation 6H are filled with Mobilgear SHC 320. Material safety data sheets for these products can available directly from Mobil Oil Corporation at:

Products & Technology Department
3225 Gallows Road
Fairfax, VA 22037
Phone: (800) 662-4525 or
Phone: (703) 849-3265

For material safety data sheets pertaining to other products used in the manufacture of the Falk Ultramite contact:

Rexnord Industries, LLC, Gear Group
Customer Service Department
3001 W. Canal Street
Milwaukee, WI 53208-4200
Phone: (414) 342-3131

Table 4 — Approximate Oil Quantities — Liters ‡

Mounting Position	DRIVE SIZE																	
	Double Reduction									Triple Reduction								
	03UC2	04UC2	06UC2	07UC2	08UC2	09UC2	10UC2	12UC2	14UC2	03UC3	04UC3	06UC3	07UC3	08UC3	09UC3	10UC3	12UC3	14UC3
1	.6	.6	1.7	2.8	4.6	10.5	11.0	17.0	24.0	.8	.9	1.8	3.0	6.4	11.5	11.0	24.0	24.0
2	.6	.6	2.2	4.3	7.3	12.7	22.0	31.0	49.0	.8	.9	2.6	5.2	7.3	12.7	23.0	49.0	50.0
3	.8	1.2	2.6	4.8	7.8	12.7	22.0	31.0	49.0	1.0	1.5	3.0	5.8	7.8	12.7	23.0	49.0	50.0
4	.8	1.2	2.9	5.8	7.1	12.7	19.0	28.0	41.0	1.0	1.5	3.6	7.4	7.1	12.7	20.0	41.0	43.0
5	.8	1.5	3.7	6.4	10.5	17.5	32.0	47.0	72.0	1.7	2.3	5.0	9.4	10.5	17.5	32.0	72.0	72.0
6	1.0	1.7	3.4	6.4	10.1	17.2	26.0	38.0	65.0	1.5	2.3	5.0	9.4	10.1	17.2	27.0	65.0	67.0
7	.6	.6	1.7	3.3	2.6	5.5	8.0	14.0	20.	.8	.9	2.2	3.4	2.4	6.0	8.0	20.0	20.0
8	.8	1.4	3.1	6.3	9.5	16.0	22.0	45.0	65.0	1.7	2.1	5.0	10.0	9.0	16.0	22.0	65.0	65.0
9	1.0	1.6	3.6	6.8	10.5	17.0	28.0	43.0	65.0	1.5	2.1	5.0	9.0	10.0	19.0	29.0	65.0	67.0

OBTAIN QUANTITIES FOR REDUCTIONS BELOW BY COMBINING PRIMARY & SECONDARY (Separate Oil Sumps) QUANTITIES FROM ABOVE

DRIVE SIZE	Quadruple Reduction					Quintuple Reduction				
	06UC4	07UC4	08UC4	09UC4	10UC4	06UC5	07UC5	08UC5	09UC5	10UC5
Primary	04UC2	04UC2	06UC2	06UC2	07UC2	04UC3	04UC3	06UC2	06UC2	07UC2
Secondary	06UC2	07UC2	08UC2	09UC2	10UC2	06UC2	07UC2	08UC3	09UC3	10UC3

‡ Convert quantities using the following: Liters to US Gallons = liters x 0.26, Liters to Imperial Gallons = liters x 0.22, Liters to US Quarts = liters x 1.057.

LUBRICANT QUANTITIES FOR INCLINED MOUNTING SIZES 03 & 04

For inclinations within $\pm 5^\circ$, use standard lubricant quantity as shown in Table 4, on Page 5.

For inclinations above 5° , use lubricant quantity (liters) as shown in Tables 5 & 6 below.

SHAFT INCLINED

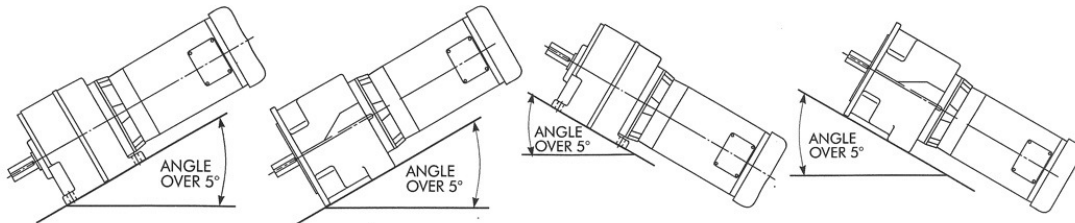

TABLE 5 — Approximate Oil Quantities – Liters ‡

Shaft Inclined Above 5°	Drive Type	DRIVE SIZE			
		03UC2	03UC3	04UC2	04UC3
Down	Base Mount	0.8	1.7	1.5	2.3
	Flange Mount	0.8	1.7	1.4	2.1
Up	Base Mount	1.0	1.5	1.7	2.3
	Flange Mount	1.0	1.5	1.6	2.1

‡ Convert quantities using the following: Liters to US Gallons = liters x 0.26, Liters to Imperial Gallons = liters x 0.22, Liters to US Quarts = liters x 1.057.

ELEVATION INCLINED

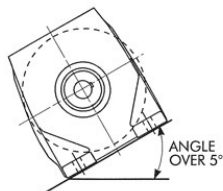

TABLE 6 — Approximate Oil Quantities – Liters ‡

Drive Type	DRIVE SIZE			
	03UC2	03UC3	04UC2	04UC3
Base Mount	0.8	1.0	1.2	1.5
Flange Mount	0.8	1.0	1.2	1.5

‡ Convert quantities using the following: Liters to US Gallons = liters x 0.26, Liters to Imperial Gallons = liters x 0.22, Liters to US Quarts = liters x 1.057.

**LUBRICANT LEVELS & QUANTITIES FOR INCLINE MOUNTING
SIZES 06 & 07**

For inclined drives, it is important to fill to the correct oil level plug as shown below.

NOTE: Follow instructions for the drive at the correct inclination.

ELEVATION INCLINED

Oil quantities will vary depending on the angle of incline and ratio. Maximum oil quantity (liters) as shown in Table 7 & 8 below.

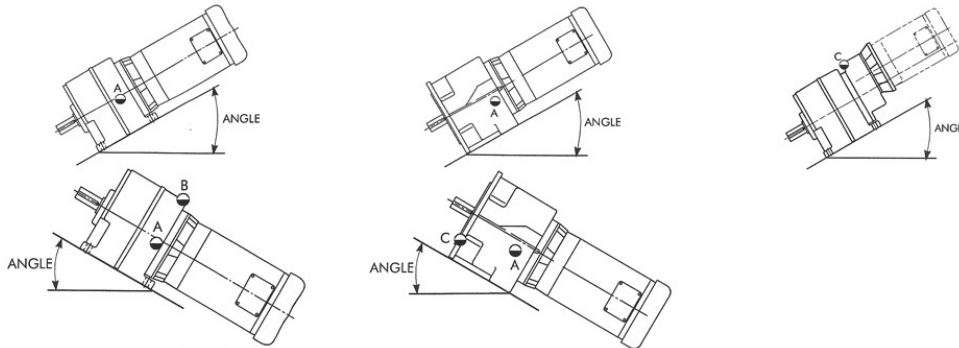

TABLE 7 — Approximate Oil Quantities & Plug Positions – Liters ‡

Shaft Down		DRIVE SIZE							
		06UC2		06UC3		07UC2		07UC3	
Degrees of Incline	Drive Type	Quantity	Plug Position	Quantity	Plug Position	Quantity	Plug Position	Quantity	Plug Position
All	Base Mount	3.7	A	5.0	C	6.4	A	9.4	C
	Flange Mount	3.1	A	5.0	C	6.3	A	10	C
Shaft Up		06UC2		06UC3		07UC2		07UC3	
Degrees of Incline	Drive Type	Quantity	Plug Position	Quantity	Plug Position	Quantity	Plug Position	Quantity	Plug Position
0° - 30°	Base Mount	2.0	A	2.2	A	3.5	A	3.7	A
	Flange Mount	2.0	A	2.2	A	4.0	A	4.2	A
31° - 60°	Base Mount	3.4	B	5.0	B	6.4	B	9.4	B
	Flange Mount	3.6	C	5.0	C	6.8	C	9.4	C

‡ Convert quantities using the following: Liters to US Gallons = liters x 0.26, Liters to Imperial Gallons = liters x 0.22, Liters to US Quarts = liters x 1.057.

SHAFT INCLINED

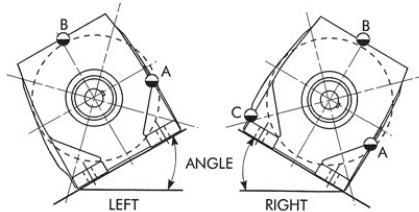

TABLE 8 — Approximate Oil Quantities & Plug Positions – Liters ‡

Degrees of Incline	Drive Type	DRIVE SIZE							
		06UC2		06UC3		07UC2		07UC3	
		Quantity	Plug Position	Quantity	Plug Position	Quantity	Plug Position	Quantity	Plug Position
0° - 50° Left	Base Mount	5.5	A	5.0	A	6.5	A	9.5	A
51° - 90° Left		3.5	B	5.0	B	6.5	B	9.5	B
0° - 20° Right		1.7	A	1.8	A	2.8	A	3.0	A
21° - 65° Right		3.5	C	5.0	C	6.5	C	9.5	C
66° - 90° Right		3.5	B	5.0	B	6.5	B	9.5	B

‡ Convert quantities using the following: Liters to US Gallons = liters x 0.26, Liters to Imperial Gallons = liters x 0.22, Liters to US Quarts = liters x 1.057.

LUBRICANT LEVELS & QUANTITIES FOR INCLINE MOUNTING SIZES 08, 09, 10. For Sizes 12 & 14, Contact the Factory

For inclined drives, it is important to fill to the correct oil level plug as shown below.

NOTE: Follow instructions for the drive at the correct inclination.

ELEVATION INCLINED

Oil quantities will vary depending on the angle of incline and ratio. Maximum oil quantity (liters) as shown in Table 9 & 10 below.



TABLE 9 — Approximate Oil Quantities & Plug Positions – Liters ‡

Shaft Down		DRIVE SIZE					
		08UC		09UC		10UC	
Degrees of Incline	Drive Type	Quantity	Plug Position	Quantity	Plug Position	Quantity	Plug Position
0° - 70°	Base Mount	10.5	A	17.5	A	26	A
	Flange Mount	9.5	A	16.0	A	22	A
Shaft Up		06UC2		06UC3		07UC2	
Degrees of Incline	Drive Type	Quantity	Plug Position	Quantity	Plug Position	Quantity	Plug Position
0° - 20°	Base Mount	7.0	A	13	A	20	A
	Flange Mount	7.5	A	12.5	A	19	A
21° - 90°	Base Mount	10	B	17	B	27	B
	Flange Mount	10.5	B	19	B	29	B

‡ Convert quantities using the following: Liters to US Gallons = liters x 0.26, Liters to Imperial Gallons = liters x 0.22, Liters to US Quarts = liters x 1.057.

SHAFT INCLINED

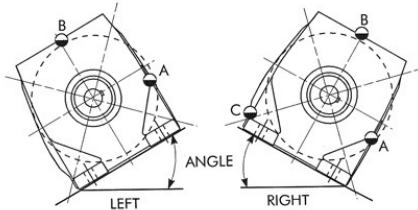

TABLE 10 — Approximate Oil Quantities & Plug Positions – Liters ‡

Degrees of Incline	Drive Type	DRIVE SIZE					
		08UC		09UC		10UC	
		Quantity	Plug Position	Quantity	Plug Position	Quantity	Plug Position
0° - 50° Left	Base Mount	13	A	19	A	27	A
51° - 90° Left		13	B	19	B	27	B
0° - 20° Right		4.5	A	7.0	A	10	A
21° - 65° Right		12	C	18	C	26	C
66° - 90° Right		12	B	18	B	26	B

‡ Convert quantities using the following: Liters to US Gallons = liters x 0.26, Liters to Imperial Gallons = liters x 0.22, Liters to US Quarts = liters x 1.057.