



900 POWERLIFT OPERATOR MANUAL

Model 9001911



Introduction

A walking operator controls this machine, and it is intended to be used by professional operators in commercial applications. The machine is designed primarily for lifting reel mower cutting units into a Foley reel grinder. Using this product for purposes other than its intended use could prove dangerous to the operator and bystanders.

Read this information carefully to learn how to operate and maintain the product properly and to avoid injury and product damage. The operator is responsible for operating the product properly and safely.

Visit www.foleyco.com for more information, including help finding a dealer, or to register the product.

When service is needed, use genuine Foley parts. Use of anything other than genuine Foley parts may void your warranty. For additional information, contact an authorized Foley distributor and be prepared to provide the model and serial numbers.

Receiving Instructions

Every unit is thoroughly tested and inspected prior to shipment. However, it is possible that the unit may incur damage during transit. If damage is detected upon delivery, make a note of it on the SHIPPER RECEIVER.

Remove all packing and strapping material, inspect for damage. IF DAMAGE IS EVIDENT, FILE A CLAIM WITH THE CARRIER IMMEDIATELY!

Operating Conditions

This machine is intended for indoor use only.

AMBIENT TEMPERATURE: +5°C/40°F to +40°C/100°F

RELATIVE HUMIDITY: 50% RH, +40°C/100°F.

Higher RH may be allowed at lower temperatures.

No condensation must be present.

ALTITUDE: up to 1000m/3280 ft. above mean sea level.

TRANSPORTATION AND STORAGE: -25°C/-15°F to +55°C/130°F

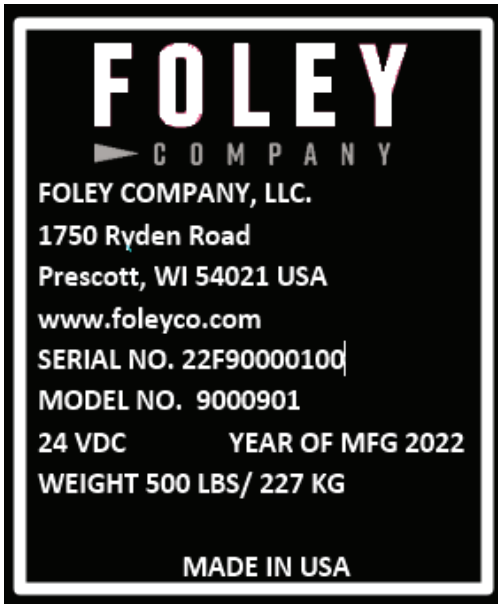

Table Of Contents

Safety	2-4
Setup	5
Safety Decals	6
Periodic Maintenance	6-7
Product Overview	8
Operation	9
Battery Charging & Care	10
Maintenance/Adjustments	11
Parts Diagram	12-15
Electrical Diagram	16



Figure 2
Safety-Alert Symbol

This manual identifies potential hazards and has safety messages identified by the Safety-Alert Symbol (Figure 2), which signals a hazard that may cause serious injury or death if the recommended precautions are not followed.

General Safety

This product is capable of causing personal injury. Always follow all safety instructions to avoid serious personal injury.

- Read and understand the contents of this manual before using.
- Use full attention while operating the machine. Do not engage in any activity that causes distractions; injury or property damage may occur.
- Do not put hands or feet near moving components of the machine or under the load.
- Do not operate the machine without all guards and other safety protective devices in place and functioning on the machine.
- Keep the machine away from bystanders while it is moving.
- Keep bystanders and pets away from the machine.
- Keep children out of the operating area. Never allow children to operate the machine.
- Stop the machine, press the emergency stop switch before leaving machine. Wait for all moving parts to stop before loading, unloading or servicing the machine.
- Improperly using or maintaining this machine can result in injury. To reduce the potential for injury, comply with these safety instructions and always pay attention to the safety-alert symbol, which means caution, warning, or danger. Failure to comply with these instructions may result in personal injury or death.

Responsibilities of Operators

The following are the responsibility of the operator:

1. The unit must be inspected and maintained in accordance with the guidelines in this manual.
2. Any unit not in safe operating condition must be removed from service until it is returned to proper operating condition. All repairs and maintenance must be performed by qualified personnel.
3. Unit may only be used by authorized personnel. All operators must read and understand all operating procedures and safety guidelines in this operator manual.
4. Operator must ensure that all safety features of the unit are functioning properly before each use.

Setup - Installation

1. Remove the bag and inspect chain, carriage, forks, and legs for any damage that may have occurred during shipping. Do not use any damaged components. Contact your local distributor or Foley Company for support.
2. Install the two legs using the fasteners provided. Use an overhead hoist, forklift or other means to lift the main post and carriage from the pallet as this assembly weighs approximately 500 lbs (227 kg).
3. Attach the forks to the carriage, one on each side. The forks hook around the tubes on the sides of the carriage.
4. Locate the charge and plug. Move the Powerlift near a wall socket and plug the charger into the wall and into the main carriage. (See important grounding information below). Charge for 12 hours before use.
5. Read and understand all areas of this manual. Raise and lower carriage through full range of motion and check for any binding or travel issues.

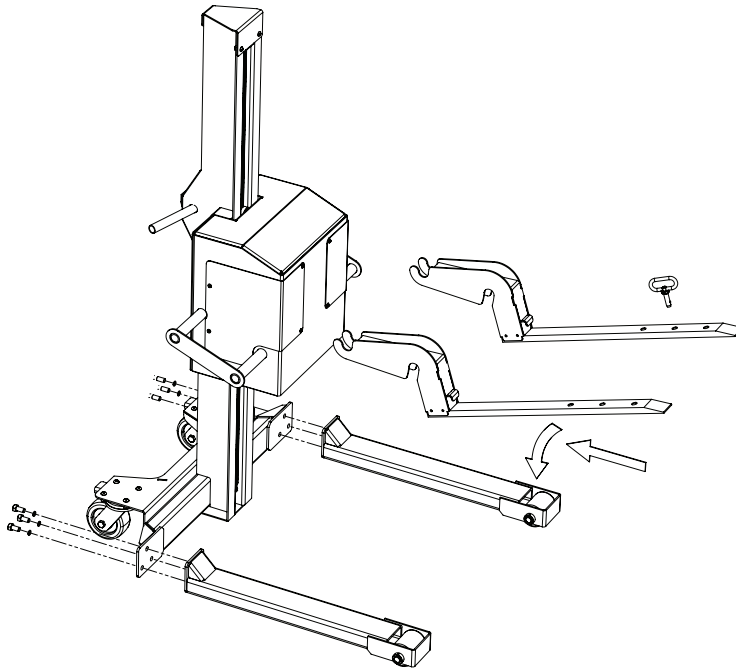

Important grounding instructions

In case of a malfunction or breakdown, grounding reduces the risk of electrical shock by providing a path of least resistance for electrical current.

The Powerlift has an electrical receptacle with an equipment grounding conductor. The receptacle must have a matching plug that is properly installed and grounded according to all local or other appropriate electrical codes and ordinances installed for charging. An improper connection may cause a dangerous electrical shock. If unsure of the proper electrical grounding procedure, contact a qualified electrician.

Safety and Instructional Decals

Safety decals and instructions are easily visible to the operator and are located near any area of potential danger. Replace any decal that is damaged or missing.

- 1  Read manual and disconnect power before servicing.
- 2  Sharp object in the vicinity which may cause injury. **Keep hands clear of sharp edges!**
- 3  Keep others at a safe distance from the equipment.
- 4  **180Kg / 400 LBS**
TABLE LIFT CAPACITY IS A MAXIMUM OF 180Kg OR 400 LBS. Exceeding the capacity may result in personal injury or damage to the equipment.
- 5  **DANGEROUS HIGH VOLTAGES PRESENT** inside the enclosure of this product. TO REDUCE THE RISK OF FIRE OR ELECTRIC SHOCK, do not attempt to open the enclosure or gain access. **SERVICE TO BE PERFORMED BY QUALIFIED PERSONNEL ONLY.**
- 6  WARNING! Do not operate without guards and covers in place. There are moving parts located behind guard.
- 7  WARNING! Do not step or stand upon this equipment. Risk of serious injury may result.
- 8  WARNING! CRUSH HAZARD keep feet clear.

Periodic Maintenance Instructions

Check the following before each use:

1. Structural deformation of frame
2. Proper operation of casters
3. Unusual noise or binding
4. Signs of wear, fatigue or loosening of any moving parts and contact areas
5. Chain tension (see chain tension adjustment section)

CAUTION Over tensioning of the chain may cause damage and/or injury

6. Wear on the chain roller bushings
7. Cover plates are securely in place

Monthly Inspections

1. Check for frayed or loose wires
2. Clean off dirt and debris at all contact areas
3. Make sure all warning and safety labels are in place and in good condition
4. Battery condition

⚠ CAUTION Children or bystanders may be injured if they move or attempt to operate the machine while it is unattended. Always press the emergency stop switch when leaving the machine unattended, even momentarily.

PERIODIC MAINTENANCE			
Daily	Monthly	Quarterly	Yearly
Clean the Powerlift by wiping it off.	Inspect the Powerlift for loose, worn, cracked or damaged components. Repair or replace if found.	Inspect the roller chains for proper tension. If tension is correct, lubricate with high quality lithium grease. If adjustment is required, adjust or replace as required and lubricate after adjustment.	Inspect battery for any leaking or corrosion.
Inspect the Powerlift for loose fasteners or components. Tighten or adjust if found.		Open the motor cover and inspect the chain and safety catch. Lubricate with high quality lithium grease if needed.	

Product Overview

Become familiar with all the controls before operating the machine.
The figure below indicates the key features of the Powerlift.

FLOOR CASTERS

The casters give the Powerlift its mobility.

DIRECTION SWITCH

Pressing the top of the switch will raise the forks, pressing the bottom of the switch will lower the forks.
Releasing the button will stop the movement of the forks.

EMERGENCY STOP SWITCH

Depressing in the emergency stop switch cuts power to the control and motor. Press if the direction switch does not stop when released or when not using the Powerlift.

FORKS

Used to hold the reel or workpiece. The forks can be moved side to side to accommodate different reel widths.

CASTER BRAKE

Brakes on the rear casters may be engaged or disengaged. Engage the brakes when raising or lowering the forks or when not using the Powerlift.

CONTROL ACCESS

Remove the control access cover to gain access to the controller and batteries.

BATTERY CHARGING

A battery charger is supplied with the Powerlift. To use, plug the charger into Powerlift before connecting the charger to a receptacle.

PIN - ROLL STOP

Place the roll-stop pin in one of the three fork holes to secure the reel while raising and lowering the forks or while moving the Powerlift.

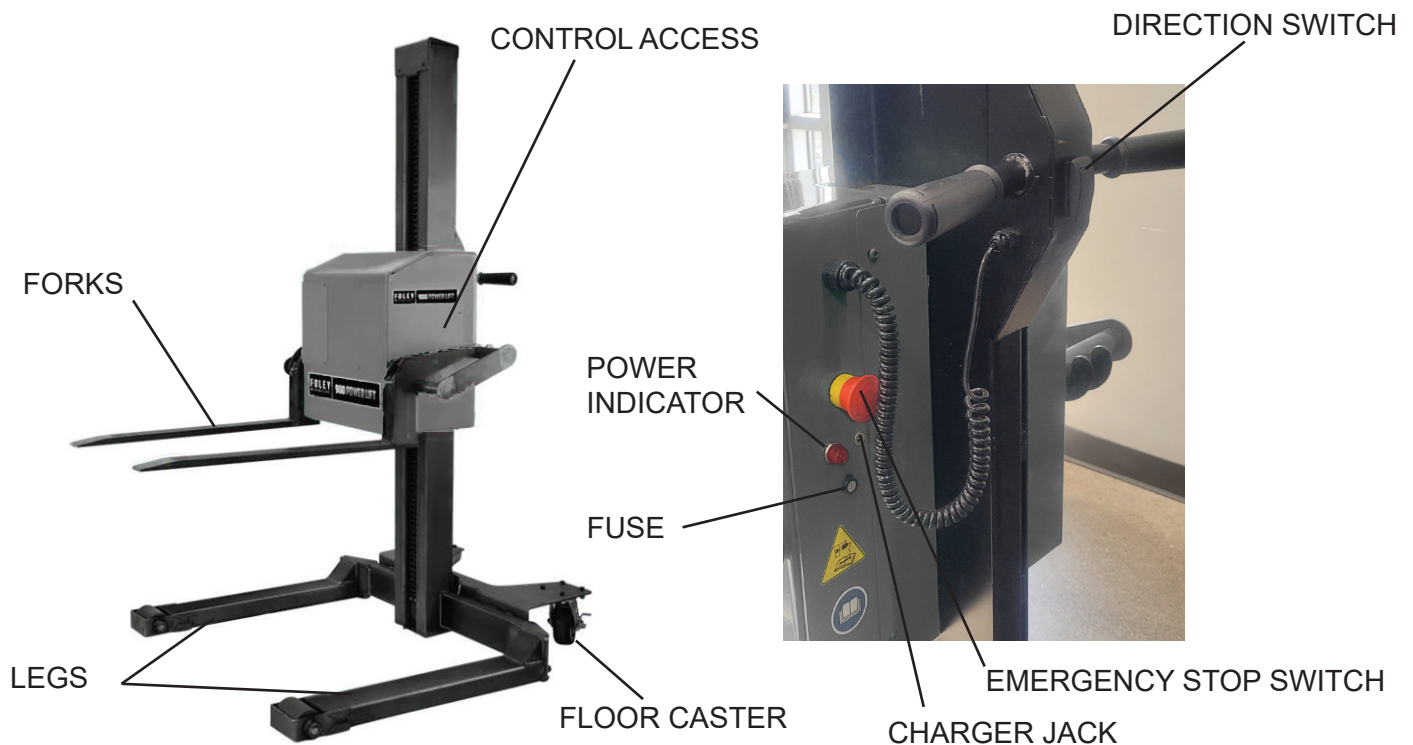

Loading Instructions

The load capacity rating as inscribed on the nameplate designates the net capacity, assuming the load is centered on the deck. This capacity must never be exceeded, as permanent damage or injury may result.

Operating Instructions

The Powerlift is a portable unit, movable with two wheels and two swivel casters. The brakes on the swivel casters are activated by pressing the “on” end of the brake arm. Release the brakes by pressing the “off” end of the brake arm. Engage the brakes when the Powerlift is not in use.

Be sure to charge the unit for 12 hours before use.

Pull out the red emergency stop switch to turn on the Powerlift, illuminating the red power indicator light.

Pressing the lift / lower switch raises and lowers the forks in the direction pressed.



WHEN THE PLATFORM REACHES THE UPPER OR LOWER END OF TRAVEL THE SWITCH MUST BE RELEASED. FAILURE TO RELEASE THE SWITCH MAY CAUSE DAMAGE TO THE ELECTRICAL SYSTEM

To transport a cutting unit, begin by lowering the forks by pressing the lower side of the lift / lower switch. Situate the cutting unit onto the forks and install pin to minimize reel movement during transport.

Press the upper portion of the raise / lower button to raise the fork off the ground. Raise only enough to allow movement of the Powerlift. Release the brakes on the caster wheels. Move the Powerlift until the cutting unit is in position to load into the grinder. Engage the caster brakes. Lower the cutting unit until it is positioned on the grinder. Remove the roll-stop pin and move the cutting unit into position. Release the brake on the casters and remove the Powerlift.

Lower the carriage and forks to the floor and move to a safe storage position and engage the caster brakes.

Reverse the process for removing the cutting unit from the grinder.

Battery Recharging & Care

The battery is completely sealed, maintenance-free and drip proof.

The provided charger operates on 120VAC or 230VAC and requires a 3-wire (grounded) cord.

Depress the Emergency Stop Button before charging. If left out the charger will not indicate the battery level and will not indicate when charging is complete.

The charger is a two-stage charger. At the beginning stage of operation the charger provides the highest current and voltage output. The LED indicator will glow red during this operation. After approximately two hours the power will gradually decrease. When the batteries reach 90% of maximum charge the LED will glow green. If the charger remains connected, it will enter a floating charge stage and maintain a 100% charge level.

A fully charged battery in good condition should read 12.65 volts. Wait at least 30 minutes after the charger has been turned off before checking the battery voltage. The charge interval of this unit will vary based on the load and frequency of use. Since the majority of applications require less than the maximum capacity and only intermittent use, the actual time between charging will only be found through experience. Battery life will be increased by fully charging after each use.

- Charge unit at least once every two weeks.
- Leave the charger plugged in when not in use. If the unit will not be used for more than one month, remove the charger and disconnect the battery.
- Do not expose the Powerlift or charger to rain or adverse conditions.
- Plug charger into machine before plugin into the wall.
- To remove the charger plug from the machine, pull back on the outer plug housing to unlock.

FLAT EDGE
OF THE PLUG
SHOULD BE
FACING THE
RED LIGHT



Maintenance

Main Chain Adjustment

Raise the carriage to access to the chain tensioner. Press the emergency stop switch to remove power.

Engage the caster brakes and place a block or other support under the carriage to provide protection in the event of chain breakage.

Tighten the nut on the bottom of the chain to 20 in-lbs. Repeat for the other side.

⚠ CAUTION Do not over-tighten; damage to the equipment or chain may occur and cause the carriage to drop unexpectedly.

CHAIN ADJUSTMENT
NUTS - 20 in-lbs



Motor Chain Adjustment

Raise the carriage to access to the chain tensioner.

Press the emergency stop switch to remove power. Remove cover to access the chain and adjuster.

Engage the caster brakes and place a block or other support under the carriage to provide protection in the event of chain breakage.

Loosen the three screws on motor support plate and press up on the motor plate to eliminate slack. When the chain is tight, tighten the three screws to lock into place.

⚠ CAUTION Do not over-tighten; damage to the equipment or chain may occur and cause the carriage to drop unexpectedly.

LOOSEN SCREWS



PUSH UP ON
MOTOR PLATE TO
INCREASE TENSION.



PARTS DIAGRAM

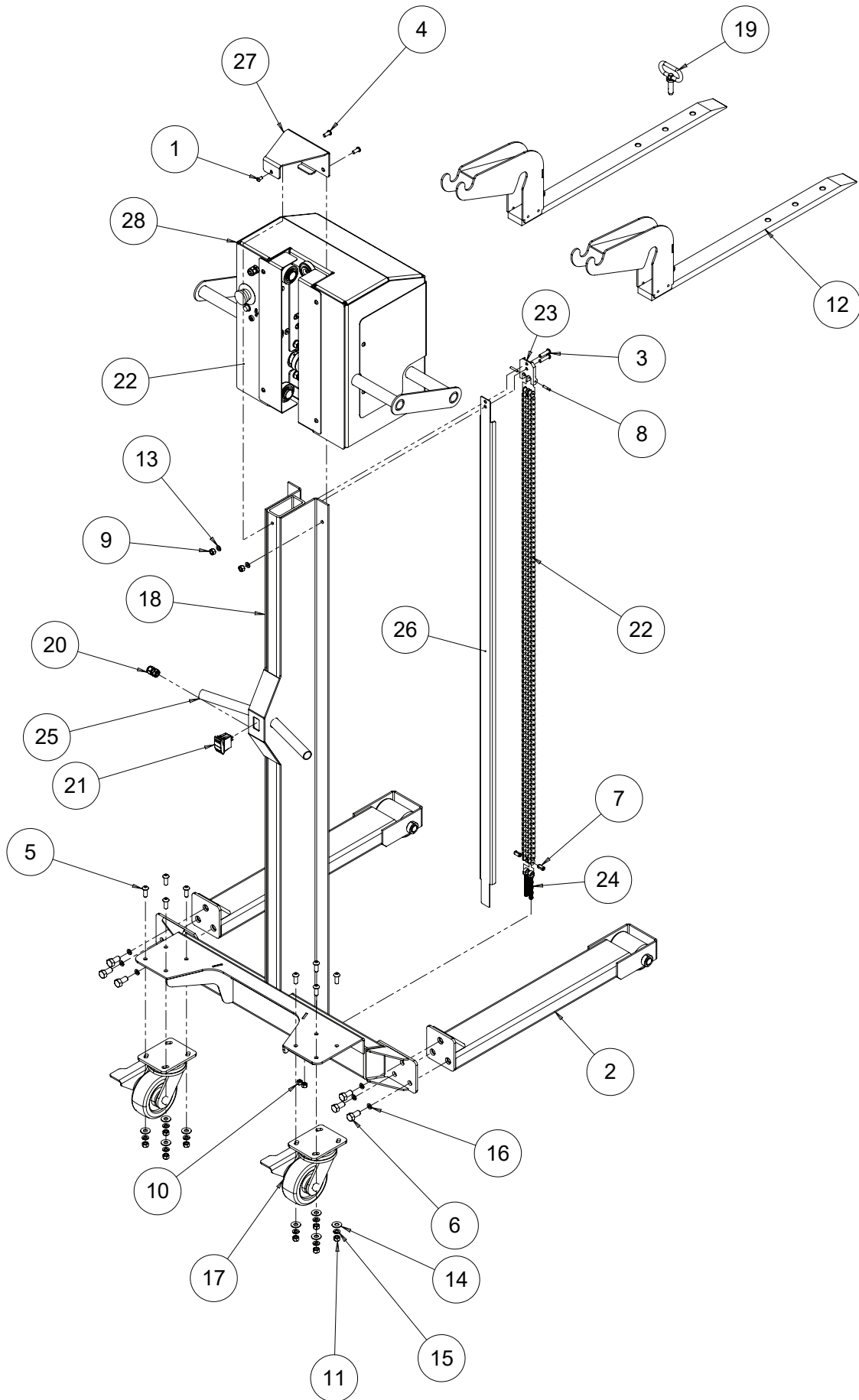

Item no.	Part No.	Description
1	B250816	1/4-20x1/2 BUTTON HEAD CAP SCREW
2	9009511	LEG ASSEMBLY
3	B312013	5/16-18x1 1/4 BUTTON HEAD CAP SCREW
4	B311213	5/16-18x3/4 BUTTON HEAD CAP SCREW
5	B371616	3/8-16x1 BUTTON HEAD CAP SCREW
6	B501601	1/2-13X1 HEX HEAD CAP SCREW
7	H181202	PIN - ROLL .188Dx.75LG
8	H181601	PIN - DOWEL .188Dx1.000LG
9	J311000	5/16-18 HEX NUT FULL
10	J317100	5/16-18 LOCKNUT FULL NYLON INST
11	J371000	3/8-16 HEX NUT
12	9009510	FORK WELDMENT
13	K311501	5/16 LOCKWASHER SPLIT
14	K370001	FLAT WASHER 3/8 HEAVY
15	K371501	3/8 LOCKWASHER SPLIT
16	K501501	1/2 LOCKWASHER SPLIT SAE
17	3706439	CASTER, LOCKING SWIVEL, 5 INCH
18	9009501	POST WELDMENT
19	3706505	LOOP GRIP 1/2 DIA PIN
20	3707029	STRAIN RELF LIQ T.19-.30W .599H
21	3707713	SWITCH RCKR MOM ON/OFF/ON WID
22	9009028	50-2 CHAIN - CLIMBING
23	9009027	CHAIN HANGER
24	3708994	ROD END 5/16-18 X 2.81 THD
25	3711220	RUBBER HANDLE BAR GRIPS W/HOLE
26	9009026	CHAIN GUIDE
27	9009024	POST CAP
28	9009504	CARRIAGE ASSEMBLY
Parts Not Shown		
	3706506	BATTERY CHARGER, 24 VDC
	9009071	DECAL SHEET (POWERLIFT)
	9009072	RETRACTABLE CORD

PARTS DIAGRAM

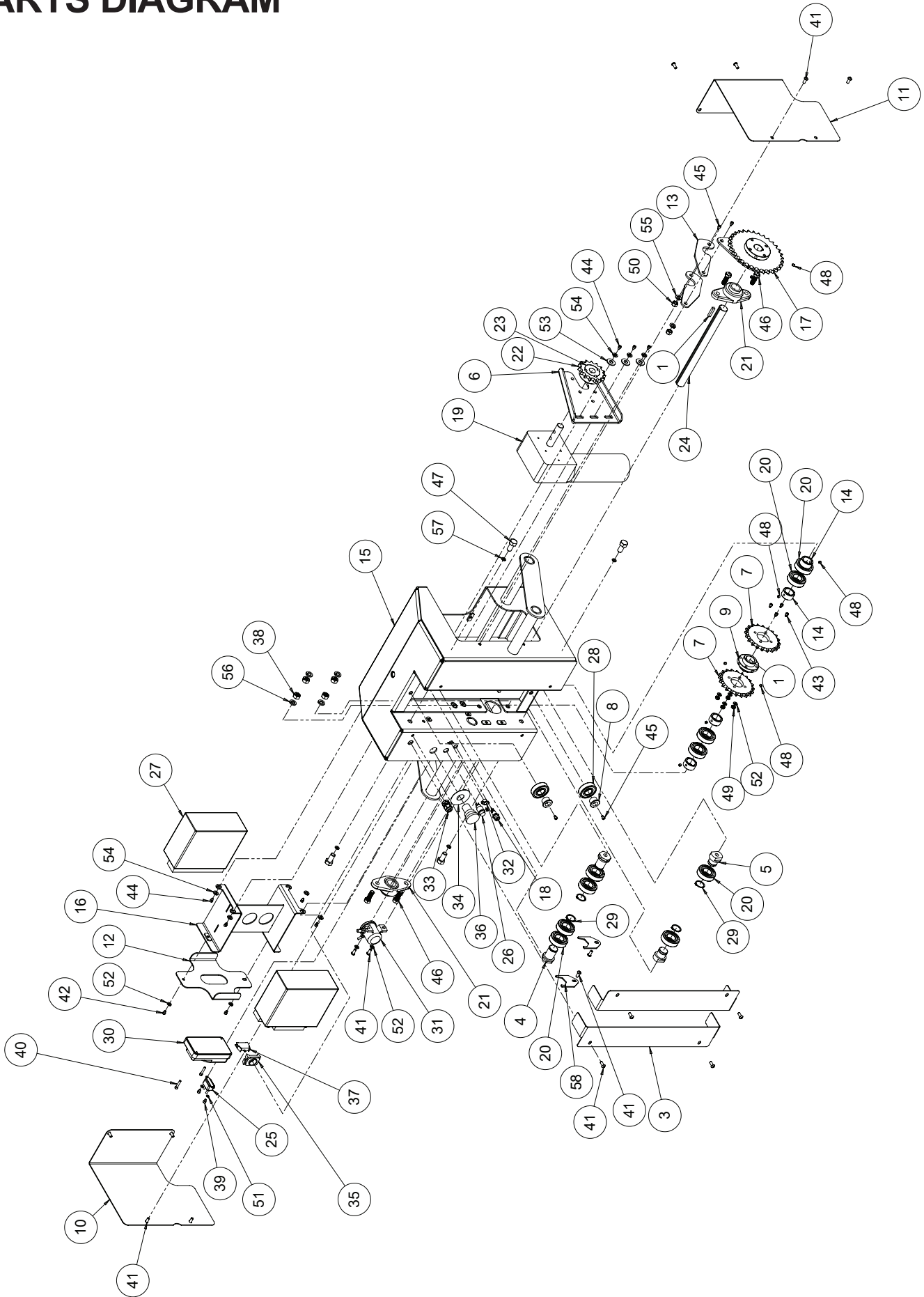

Item no.	Part No.	Description
1	80338	KEY - .25SQ x 1.25LG
2	9009020	WIRING PACK - POWERLIFT
3	9009041	BEARING GUARD
4	9009043	DBL. BEARING SHAFT
5	9009044	SINGLE BEARING SHAFT
6	9009045	MOTOR MOUNT PLATE
7	9009046	DRIVE SPROCKET
8	9009047	CENTER BEARING SHAFT
9	9009048	DRIVE HUB
10	9009050	INSP COVER - LEFT
11	9009051	INSP COVER - RIGHT
12	9009052	BATTERY HOLD DOWN
13	9009055	SAFETY CLAMP
14	9009064	BEARING SPACER
15	9009505	CARRIAGE WELDMENT
16	9009506	BATTERY MOUNT WELDMENT
17	9009507	SAFETY DRIVE
18	3706236	FUSE HOLDER PANEL MOUNT
19	9009524	MOTOR AND SPOCKET ASSEMBLY
20	3706442	ROLLER BEARING, R12-2RS
21	3706446	MOUNTED BEARING, 1.00 SHAFT
22	9009524	MOTOR AND SPOCKET ASSEMBLY
23	9009524	MOTOR AND SPOCKET ASSEMBLY
24	3706455	KEYED SHAFT, 1.00" X 12" LONG
25	3706461	CIRCUIT BREAKER, 12V, 50 AMP
26	3706471	PILOT LIGHT, 16mm LED, GRN
27	3706477	BATTERY, 12 VOLT, 18AH
28	3706479	BEARING, 22ID X 50OD X 14W
29	3706480	RETAINING RING, 1.00" SHAFT

Item no.	Part No.	Description
30	3706481	MOTOR CONTROLLER, 24V INPUT
31	3706482	CONTACTOR, TYPE 70, 24V
32	3706507	POWER PLUG, R7B, BULKHEAD
33	3707029	STRAIN RELF LIQ T.19-.30W .599H
34	3707342	RING YELLOW E-STOP
35	3707566	LATCH MTG SWITCH
36	3707567	PUSH / PULL BUTTON RED STOP
37	3707568	BLOCK CONTACT NC SWITCH
38	3711011	HEX NUT, 7/16-14, GRADE 8
39	B190834	10-32x1/2 BHSCS
40	B192031	10-32x1-1/4 SHCS
41	B251016	1/4-20x5/8 BHSCS
42	B251611	1/4-20x1 SHCS
43	B252811	1/4-20x1-3/4 SHCS FULL THD
44	B310811	5/16-18x1/2 SHCS
45	B371611	3/8-16x1 SHCS
46	B442001	3/8-16x3/4 HHCS - GRADE 5
47	B501601	1/2-13X1 HHCS
48	C250420	1/4-20x1/4 SSS CPPT
49	J252000	1/4-20 HEX JAM NUT
50	J371000	3/8-16 HEX NUT
51	K191501	#10 LOCKWASHER SPLIT
52	K251501	1/4 LOCKWASHER SPLIT
53	K310001	FLAT WASHER 5/16 SAE
54	K311501	5/16 LOCKWASHER SPLIT
55	K371501	3/8 LOCKWASHER SPLIT
56	K441501	7/16 LOCKWASHER SPLIT
57	K501501	1/2 LOCKWASHER SPLIT SAE
58	9009075	BEARING ADJUSTER LOCK PLATE
	9009072	RETRACTILE CORD (NOT SHOWN)

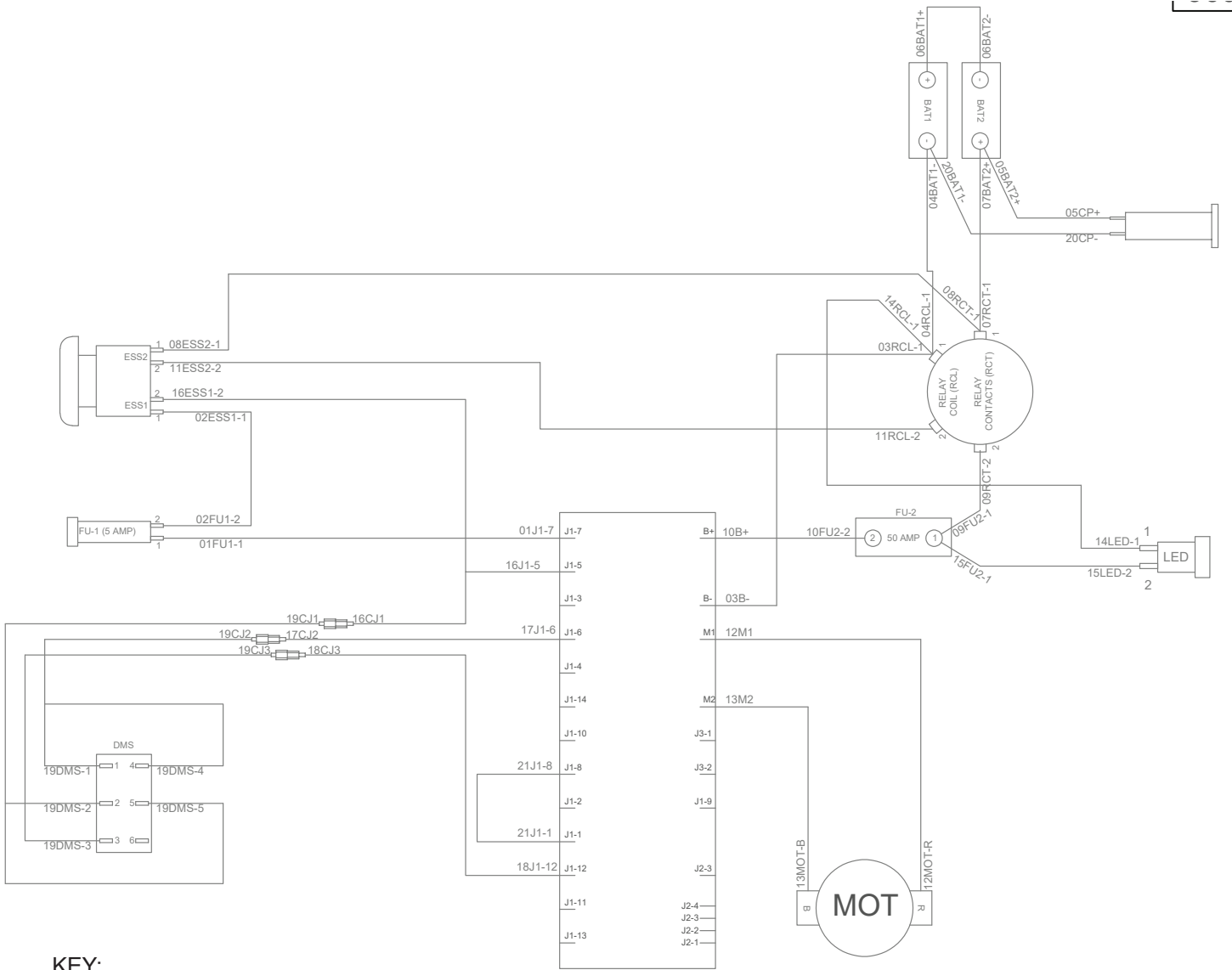

KEY:

- BAT1- BATTERY #1
- BAT2- BATTERY #2
- RCL- RELAY COIL
- RCT- RELAY CONTACT
- FU2- 50 AMP CIRCUIT BREAKER
- FU1- 5 AMP FUSE
- LED- LED INDICATOR
- MOT- GEARMOTOR
- CP- CHARGE PORT
- ESS1- E-STOP CONTACT BLOCK #1
- ESS2- E-STOP CONTACT BLOCK #2
- CJ1-CJ3 - CORD JUNCTIONS
- DMS- DIRECTIONAL MOTOR SWITCH

Customer Support

Contact Customer Support

Foley Company

1750 Ryden Rd

Prescott, WI 54021

Call: 904-507-8900

Email: Foleysupport@foleyco.com

Facebook: facebook.com/FoleyCompany

Twitter: [@Foley_Company](https://twitter.com/Foley_Company)

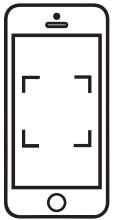

Scan on your
mobile device
to contact
customer
support

