

OPERATORS AND PARTS MANUAL
MODELS 8635 & 8640 CHIPPERS



MANUFACTURER OF OUTDOOR POWER EQUIPMENT

Products for Turf & Lawncare, Rental, Construction, Tree care, Wood Processing, Nursery & Farm Industries

Other Salsco Equipment

3-1/2" - 18", Gas, Diesel, and P.T.O, Wood/Brush Chippers
Chipper Shredder Vacuums - Tailgate & Truckloader Vacuums
Shaving Mills - Gas and Electric Greens Rollers

***Quality of Workmanship, Innovative
Design, Built to Last!***

105 School House Road
Cheshire, CT 06410 U.S.A.
800-872-5726, 203-271-1682, 203-271-2596 (Fax)
sales@salsco.com, www.salsco.com

TABLE OF CONTENTS

MODEL 8635 & 8640 WOOD/BRUSH CHIPPERS

COVER & TABLE OF CONTENTS.....Pages 1 – 2

STATEMENT OF FACT Page 3

SPECIFICATIONS & FEATURESPage 4

MACHINE REGISTRATIONPage 5

SAFETY & OPERATING INSTRUCTIONSPages 6 - 9

SERVICE & MAINTENANCE INSTRUCTIONSPage 10

PARTS DIAGRAMSPages 11-19

TORQUE CHARTSPage 20

WARRANTY POLICY/PROCEDUREPage 21

COPY OF WARRANTY CLAIM FORM.....Page 22

COPY OF DEALER DELIVERY REPORT AND WARRANTY CARD.....Page 23

SERVICE SCHEDULE LOGPage 24

SALSCO, INC.
105 School House Road
Cheshire, CT 06410
800-872-5726, 203-271-1682
203-271-2596 (Fax)
www.salsco.com, sales@salsco.com

STATEMENT OF FACT

You have just purchased the highest quality, most dependable, Chipper on the market today. This unit has the ability to meet exact standards and perform for years with minimum downtime. **HOWEVER**, it cannot read nor will it understand this manual no matter how long you leave it on top of the machine.

It is your responsibility to read and understand this manual; it is also your responsibility to be certain this information is passed along to anyone who is expected to operate this equipment. Should you choose not to read, understand and pass along the information provided you, please expect equipment failure and possible injuries to persons around this equipment.

For the safety of the operator, it is imperative that this manual is carefully read and understood.

Once you have read this manual, it is your responsibility to be sure that all new operators read and understand this manual, especially all cautions stated.

As a manufacturer of equipment, we have a responsibility to design a safe piece of equipment. NOTE: The important safeguards and instructions in this manual are not meant to cover all possible conditions and situations that may occur. It must be understood that common sense, caution, and care are factors, which cannot be built into any product. These factors must be supplied by the person(s) caring for and operating this equipment.

ONLY YOU CAN PREVENT ACCIDENTS!

SPECIFICATIONS & FEATURES

Models **8635 & 8640** Chippers, like all of the Salsco products, are ruggedly built to withstand high volume usage by the rental, commercial lawn care and tree care industries. Standard equipment includes heavy-duty diamond plate fenders with safety light guards, stop, directional and safety lights, large 26" diameter high-speed tires, lockable tool box, lockable battery box, lockable gas and hydraulic fuel tanks. Orange polyester powder coat paint offers protection against ultra violet discoloration, outdoor weatherability and resists most chemicals.

The trailer frame, constructed of 3" x 2" x ¼" wall rectangular steel tube, continuous welds for strength and gusseted where needed provides years of towing ease. The 2,400-lbs. Torflex Axle also features an independent suspension, cushioned with rubber, providing a smooth, quiet ride with no transfer of road shock from one wheel to the other.

Models 8635 & 8640 Chippers have an infeed opening of 6" x 12" to eliminate most pruning of limbs. These units will handle Christmas trees, palm fronds, vines and leafy material, with ease. There are two bed knives, one horizontal and one vertical to prevent materials such as palm fronds and vines from wrapping around the feed roll. Our feed roll measures 7" in diameter by 12" long and has replaceable blades. Speed of the hydraulic feed is easily adjusted at the hydraulic pump and can be controlled by the control bar positioned at the top of the chipper chute to forward/off/reverse. The chipper disc is 1" thick by 26" in diameter and is mounted on a 2" diameter steel shaft with six-exhaust blades.

Safety is always our number one concern at Salsco. With the infeed pan down, the feed roll is 61" from the edge of the pan. The operator would have to work very hard to get a leg or arm caught in the feed roll. Also provided on each machine is a full set of safety decals.

Simple and safe operation, easy to maintain, and built to last;
Salsco, Models 8635 & 8640, 6" x 12" Chippers!

MACHINE REGISTRATION

MANUFACTURED BY:

SALSCO, INC.
105 School House Rd., Cheshire, CT 06410
800-872-5726, 203-271-1682, 203-271-2596 (Fax)
sales@salsco.com www.salsco.com

THIS MANUAL COVERS MODEL (s): 8635 & 8640 WOOD/BRUSH CHIPPERS

This company reserves the right to discontinue, add improvements to, or change the design of any model or product at any time without obligation to improve existing machines, either by changing the design or adding new parts.

It has been and will continue to be the policy of SALSCO to update existing machines at its own discretion. Whenever possible, new designs will be made in such a way that they can be "Retro Fit" if so desired.

Record in the space provided below the model and serial number of this unit. Please retain these numbers for future reference.

No parts orders will be accepted **WITHOUT MODEL NUMBERS OR PART NUMBERS**. All part numbers are listed in this manual.

Serial Number

Model Number

NOTE: Be sure to complete your warranty card. This will insure immediate processing of any warranty claims.

READ AND UNDERSTAND THIS MANUAL BEFORE STARTING THE MACHINE

1/06

CAUTIONS

READ THOROUGHLY THE OPERATOR SAFETY INSTRUCTIONS ON THE FOLLOWING THREE PAGES, WHICH ARE THE AMERICAN NATIONAL STANDARD OF POWERED SHREDDERS/GRINDERS, SAFETY SPECIFICATIONS PROVIDED BY ANSI AND THE O.P.E.I.

THE FOLLOWING CAUTIONS ARE PROVIDED BY SALSCO AS A QUICK REFERENCE ONLY AND ARE NOT MEANT TO REPLACE THE PRECAUTIONS ON THE FOLLOWING PAGES.

1. **ALWAYS** use protective eyewear when machine is in operation.
2. **ALWAYS** use gloves and wear ear protection when machine is in operation.
3. **NEVER** put hands, legs or any part of your body into or near Chipper intake or discharge openings.
4. **NEVER** run with guards removed.
5. **ALWAYS** allow machine to cool off, remove key and put engine in neutral before attempting any maintenance, or repair.
6. **BE SURE** machine has stopped completely, engine is off, key is removed and spark plug is disconnected before attempting any service or maintenance.
7. **NEVER** stand in front of chipper infeed hopper. It is possible for a chip or piece of wood to be thrown out.
8. **BE SURE** the machine is parked on a dry level surface before starting operation.
9. **DO NOT** operate with loose clothing or long unrestrained hair. Be sure vines and branches are not wrapped around your body parts.
10. **DO NOT** operate on ice or any other slippery surface. Be sure area around machine is clear and clean. You do not want to trip into the machine.
11. **NEVER** leave machine running unattended, especially around youngsters or persons not instructed in the safe operation of this machine.
12. **READ** and understand federal guidelines provided with this manual.

BRUSH CHIPPERS
ANSI Z133.1-2006
American National Standard for Arboricultural Operations
Safety Requirements

5.3 Brush Chippers

- 5.3.1 The items contained in section 5.1 shall always be included in the review of this section.
- 5.3.2 Access panels (for example, guards) for maintenance and adjustment, including discharge chute and cutter housing, shall be closed and secured prior to starting the engine of brush chippers. These access panels shall not be opened or unsecured until the engine and all moving parts have come to a complete stop (see Annex C, General Safety Procedures That Apply to All Tree Work).
- 5.3.3 Rotary drum or disc brush chippers not equipped with a mechanical infeed system shall be equipped with an infeed hopper not less than 85 inches (2.15 m) measured from the blades or knives to ground level over the center line of the hopper. Side members of the infeed hopper shall have sufficient height so as to prevent workers from contacting the blades or knives during operations.
- 5.3.4 Rotary drum or disc brush chippers not equipped with a mechanical infeed system shall have a flexible anti-kickback device installed in the infeed hopper to reduce the risk of injury from flying chips and debris.
- 5.3.5 Chippers equipped with a mechanical infeed system shall have a quick-stop and reversing device on the infeed system. The activating mechanism for the quick-stop and reversing device shall be located across the top, along each side, and close to the feed end of the infeed hopper within easy reach of the worker.
- 5.3.6 Vision, hearing, and/or other appropriate personal protective equipment shall be worn when in the immediate area of a brush chipper in accordance with section 3.4, Personal Protective Equipment.
- 5.3.7 Arborists, mechanics, and other workers shall not, under any circumstances, reach into the infeed hopper when the cutter disc, rotary drum, or feed rollers are moving.
- 5.3.8 When trailer chippers are detached from the vehicles, they shall be chocked or otherwise secured in place.
- 5.3.9 When in a towing position, chipper safety chains shall be crossed under the tongue of the chipper and properly affixed to the towing vehicle.
- 5.3.10 See section 8.6, Brush Removal and Chipping, for additional requirements.

BRUSH REMOVAL AND CHIPPING
ANSI Z133.1-2006
American National Standard for Arboricultural Operations
Safety Requirements

8.6 Brush Removal and Chipping

- 8.6.1 Traffic control around the jobsite shall be established prior to the start of chipping operations along roads and highways (see section 3.2, Traffic Control Around the Jobsite).
- 8.6.2 Brush and logs shall not be allowed to create hazards in the work areas.
- 8.6.3 To prevent an entanglement hazard, loose clothing, climbing equipment, body belts, harnesses, lanyards, or gauntlet-type gloves (for example, long-cuffed lineman's or welder's gloves) shall not be worn while operating chippers.
- 8.6.4 Personal protective equipment shall be worn when in the immediate area of chipping operations in accordance with section 3.4, Personal Protective Equipment, of this standard.
- 8.6.5 Training shall be provided in the proper operation, feeding, starting, and shutdown procedures for the chipper being used.
- 8.6.6 Maintenance shall be performed only by those persons authorized by the employer and trained to perform such operations.
- 8.6.7 Brush and logs shall be fed into chippers, butt or cut end first, from the side of the feed table center line, and the operator shall immediately turn away from the feed table when the brush is taken into the rotor or feed rollers. Chippers should be fed from the curb-side whenever practical.
- 8.6.8 The brush chipper discharge chute or cutter housing cover shall not be raised or removed while any part of the chipper is turning or moving. Chippers shall not be used unless a discharge chute of sufficient length or design is provided that prevents personal contact with the blades (see Annex C, General Safety Procedures That Apply to All Tree Work).
- 8.6.9 Foreign material, such as stones, nails, sweepings, and rakings, shall not be fed into chippers.
- 8.6.10 Small branches shall be fed into chippers with longer branches or by being pushed with a long stick.
- 8.6.11 Hands or other parts of the body shall not be placed into the infeed hopper. Leaning into or pushing material into infeed hoppers with feet is prohibited.
- 8.6.12 While material is being fed into the chipper infeed hopper chute, pinch points continually develop within the material being chipped and between the material and machine. The operator shall be aware of this situation and respond accordingly.
- 8.6.13 When feeding a chipper during roadside operations, the operator shall do so in a manner that prevents him or her from stepping into traffic or being pushed into traffic by the material that is being fed into the chipper.
- 8.6.14 When using a winch in chipper operations, the operator shall ensure that the winch cable is properly stored before initiating chipper operations.
- 8.6.15 Refer to section 5.3, Brush Chippers, for additional information.

OPERATING INSTRUCTIONS

1. Be sure all guards are in place.
2. Check all chambers to be sure they are free and clear of debris.
3. Set direction of discharge chute.
4. Set feed handle in reverse position.
5. Check engine oil and fuel levels, as per engine manufacturer specifications.
6. Set engine throttle just above idle, and set choke.
7. Start engine and let idle for a few minutes to warm up. Open chipper feed tray, at this time.

HINTS

1. When operating machine, stand off to the side of the feed hopper when feeding wood into the machine. **NEVER STAND DIRECTLY IN FRONT OF THE HOPPER WHEN FEEDING WOOD INTO THE MACHINE.**
2. When using the chipper and you have a short piece of wood bouncing around and not being grabbed by the feed roll, **LEAVE IT! DO NOT TRY TO PUSH IT THROUGH WITH ARMS OR LEGS!** The next limb will push it through.
3. When through with the job let the engine run at full RPM, making sure all material is run through the machine before shutting it down. This will prevent any injuries from flying debris when the machine is started up at the next job.

WHILE PERFORMING MAINTENANCE OR REPAIR, ALWAYS REMOVE KEY FROM ENGINE AND REMOVE SPARK PLUG WIRE

SERVICE SCHEDULE

1. **ENGINE** – Follow service maintenance schedule set forth by the manufacturer in the engine manual.
2. **GREASE** - all main bearings once a day. **DO NOT OVER GREASE.** Wipe extra grease off bearings.
3. After using the machine, be sure to clean entire machine, especially around the engine.

NOTE: SHOULD IT BECOME NECESSARY TO REMOVE THE EXHAUST CHUTE, REMOVE SPARK PLUG WIRES AND KEY FROM ENGINE. NEVER TURN ENGINE OVER WHILE THE EXHAUST CHUTE IS REMOVED or THE IMPELLER HOUSING IS OPEN. BE SURE THE IMPELLER IS AT A COMPLETE STOP BEFORE OPENING THE IMPELLER HOUSING OR REMOVING THE EXHAUST CHUTE.

4. **SHARPEN/CHANGE CHIPPER BLADES** – Pull locking pin from the impeller housing and open housing. **DO NOT** reach in and hold the impeller with your hand instead use a piece of 2” x 4” wood to push the impeller to desired position. When re-installing the blades, be sure to use Loctite. We use **Loctite Blue 242**, removable at the factory. **BE SURE** to clean mounting surface before installing the blades, and **BE SURE** to follow the torque specifications in this manual. It is also **RECOMMENDED** that you replace the hardware whenever replacing or reversing the blades.
5. **BED KNIFE ADJUSTMENT** on hydraulic feed machines is .070. Check this clearance on all blades. **HINT:** Blades need sharpening after approximately 8-15 hours of use.

SERVICE SCHEDULE	AS NEEDED	DAILY	WEEKLY	MONTHLY
Clean Machine	X	X		
Grease Infeed Roll Bearing	X	X		
Grease Disc Shaft Bearing	X	X		
Sharpen Chipper Blades	X OR		X	
Check & Adjust Bed Knife	X OR		X	
Check all Nuts & Bolts	X	X		
Check Hydraulic Oil	X			X
Check Hydraulic Hoses	X			X

NEVER, UNDER ANY CIRCUMSTANCES START THE ENGINE WHEN THE UNIT IS OPEN OR GUARDS HAVE BEEN REMOVED, OR AT ANY TIME DURING SERVICE OR ROUTINE MAINTENANCE

ISSUED: 10-29-2009

ITEM	DESCRIPTION	PART NO	QTY
1	GUARD, BELT - FRONT & TOP	0221370	1
2	COVER, SERVICE ACCESS	0471041	1
3	BUSHING (PUMP)	0342067	1
4	PULLEY (PUMP)	0342086	1
5	V-BELT (PUMP)	0304011	1

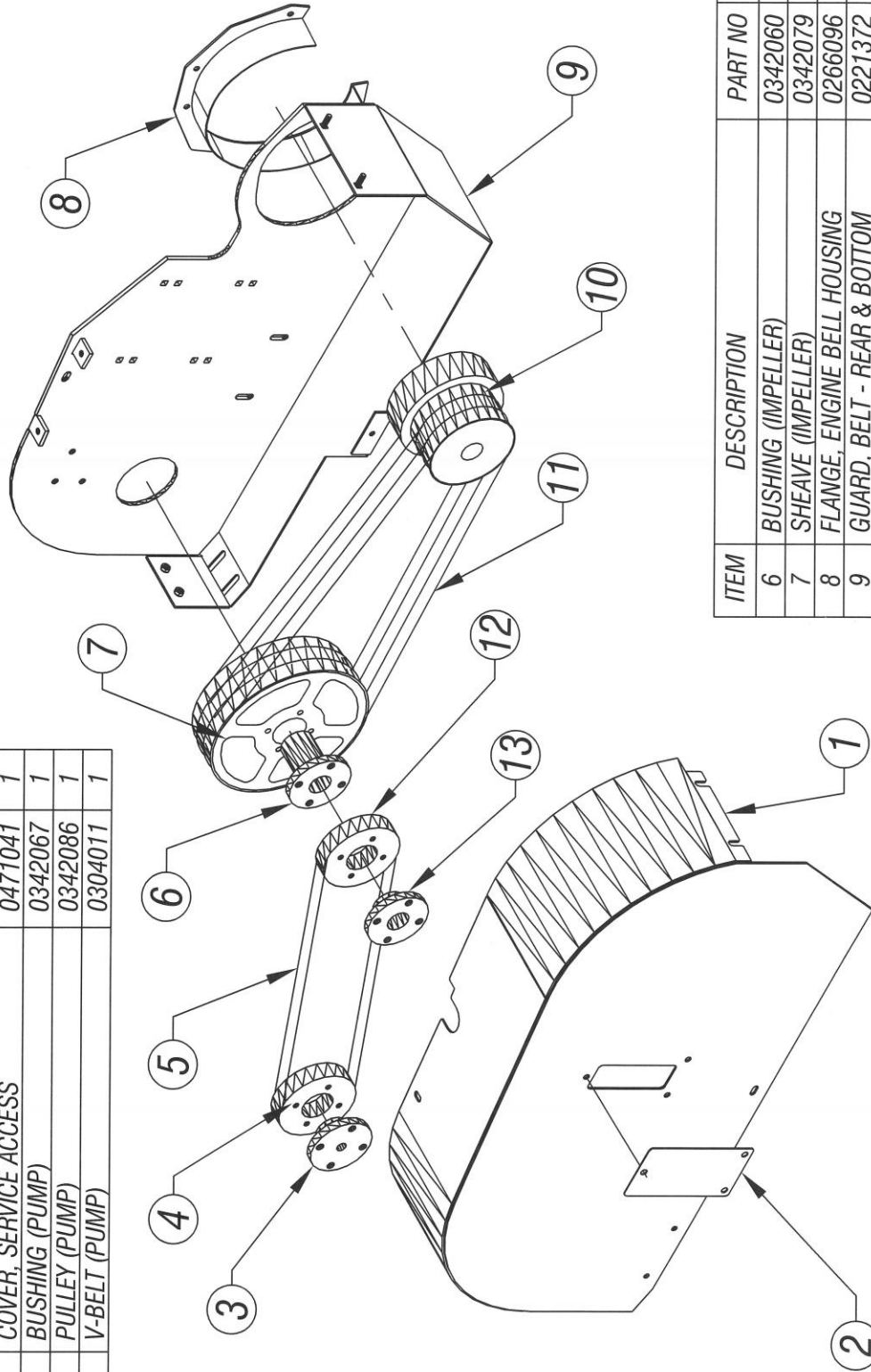

ITEM	DESCRIPTION	PART NO	QTY
6	BUSHING (IMPELLER)	0342060	1
7	SHEAVE (IMPELLER)	0342079	1
8	FLANGE, ENGINE BELL HOUSING	0266096	1
9	GUARD, BELT - REAR & BOTTOM	0221372	1
10	CLUTCH, CENTRIFUGAL WITH PULLEY	0337277	1
11	V-BELT BANDED (3 V-GROOVES)	0304039	1
12	SHEAVE (IMPELLER TO PUMP)	0342085	1
13	BUSHING (IMPELLER TO PUMP)	0342051	1

8635 / 8640 CHIPPER
 WITH KUBOTA OR YANMAR ENGINE OPTIONS - DWG #1

ISSUED: 11-20-2009

ITEM	DESCRIPTION	PART NO	QTY
1	TOWFRAME, BASE	0219380	1
2	MOUNT, ENGINE - FRONT	0276472	1
3	EXHAUST PIPE ADAPTER	0237372	1
4	MUFFLER - MODIFIED	0237435	1
5	COVER, ENGINE	0271266	1
6	ENGINE, KUBOTA 35.5 HP (DIESEL)	0337322	1
7	ENGINE, YANMAR 40 HP (DIESEL)	0337412	1
8	CONTROL PANEL KIT	0337483	1
9	MOUNT, ENGINE - REAR	0276476	1
10	BRACKET, CONTROL BOX MOUNTING	0406999	1
11	HEX NUT - GRADE 8	0338030	4
12	FLAT WASHER - GRADE 8	0353020	4
13	PLATE, ENGINE MOUNT PUSHER	0462592	2
14	ADJUSTER, ENGINE	0201048	2

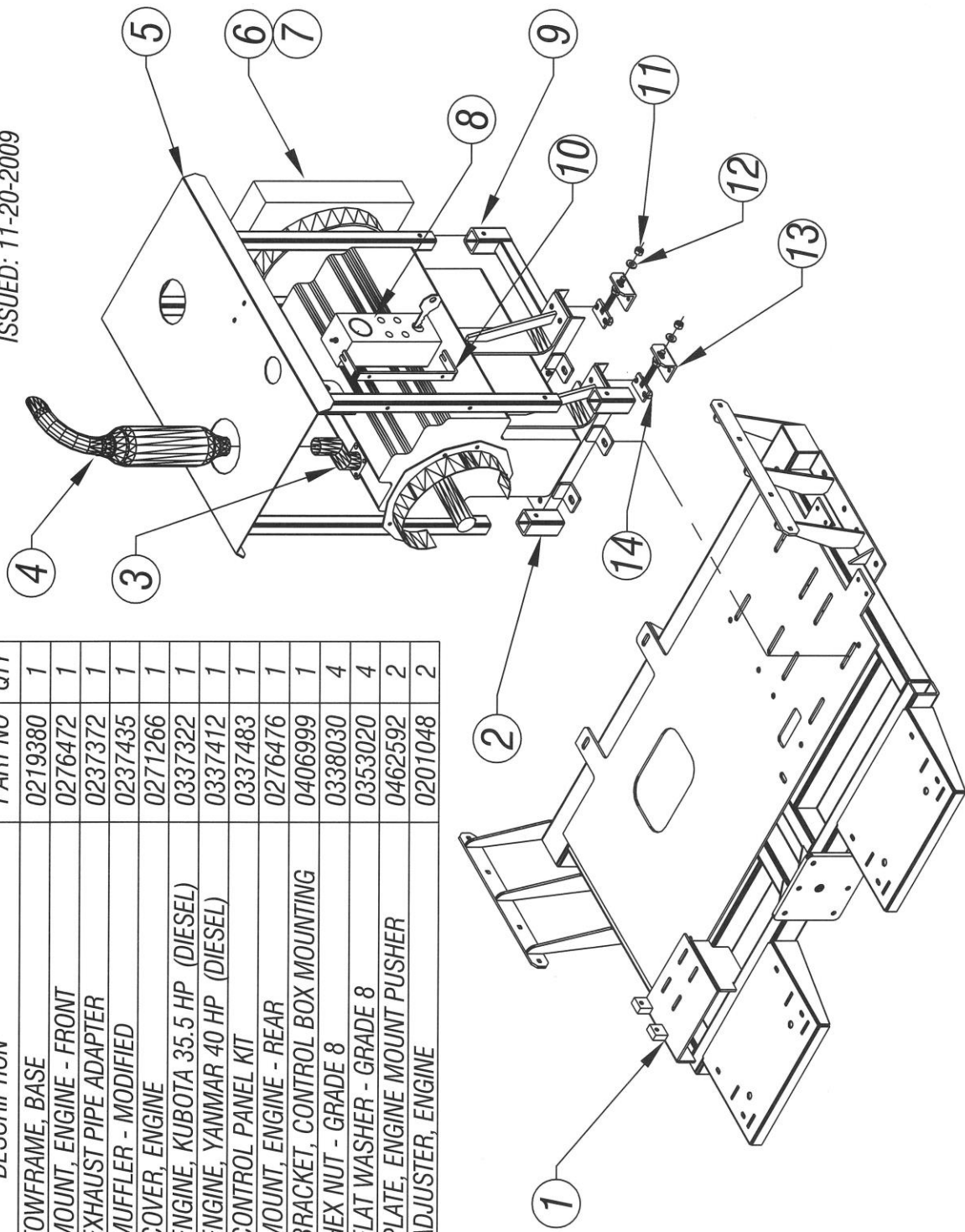

8635 / 8640 CHIPPER - KUBOTA OR YANMAR ENGINE OPTIONS - DWG #2

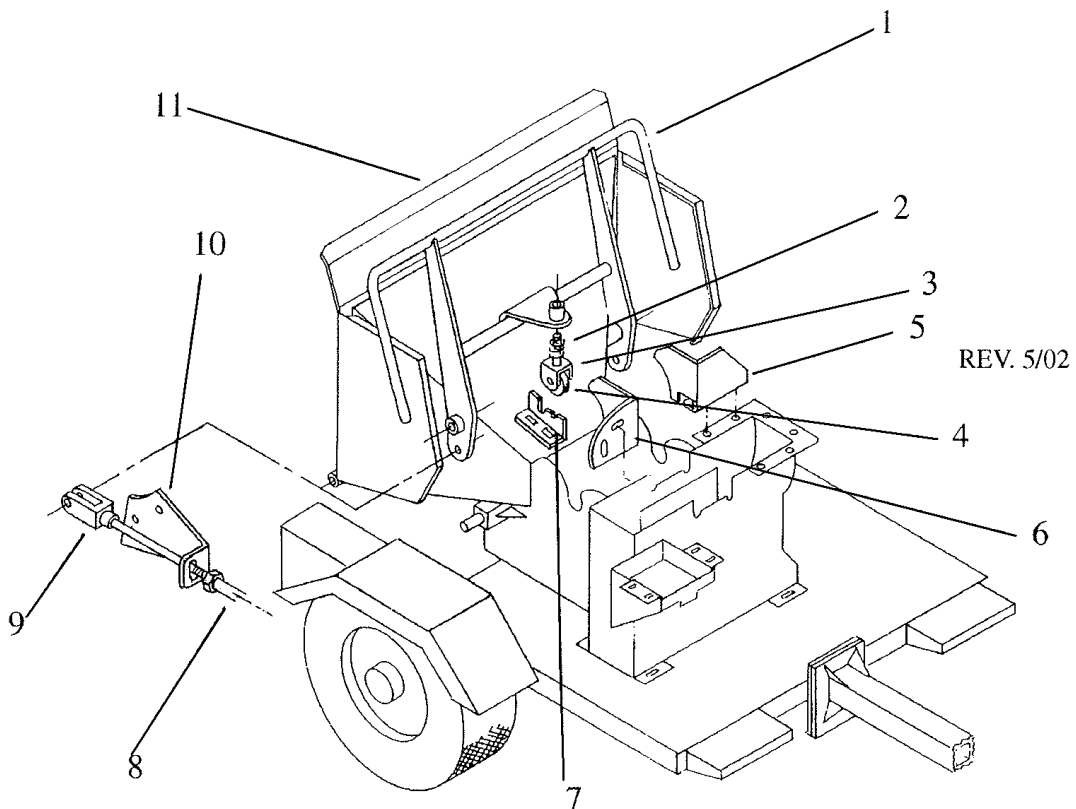

Item #	Description	Part #	Qty.
1	Handle, Power Feed	0223031	1
2	Spring, Compression	0350019	1
3	Yoke, Detent Bearing	0274007	1
4	Bearing, Ball	0303034	1
5	Guard, Left Wing	0421072	1
6	Guard, Right Wing	0421180	1
7	Plate, Detent	0441642	1
8	Cable, Push Pull	0308022	1
9	Yoke, Clevis Kit	0374022	2
10	Bracket, Cable Mounting	0406565	1
11	Door, Infeed Housing	0271182	1

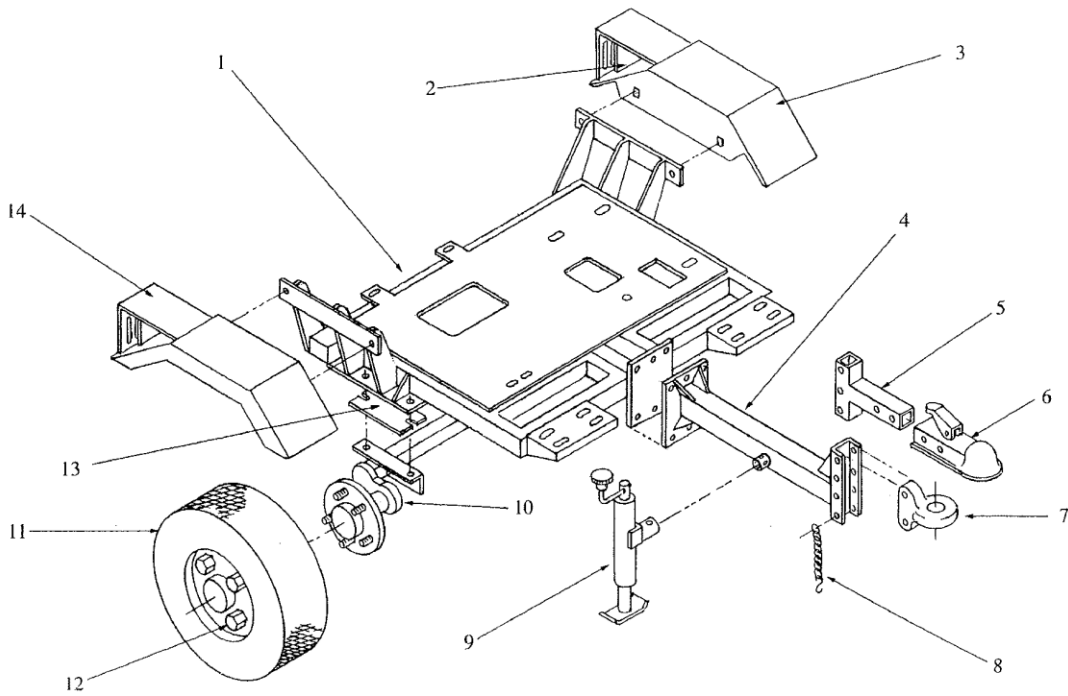

Item #	Description	Part #	Qty.
1	Tow Frame	0219254	1
2	Kit, Trailer Lights	0361006	1
3	Fender, Left	0216011	1
4	Tongue	0225067	1
5	Tongue, 2" Coupler	0225068	1
6	Coupler, 2" Ball	0325007	1
7	Pintle Ring, 3"	0325014	1
8	Safety Chain	0309018	2
9	Jack, Top Wind	0369006	1
10	Axle, Torflex	0302099	1
11	Tire/Wheel	0354025	2
12	Lug Nuts	0338306	10
13	Spacer, Axle Mounting	0449067	2
14	Fender, Right	0216012	1

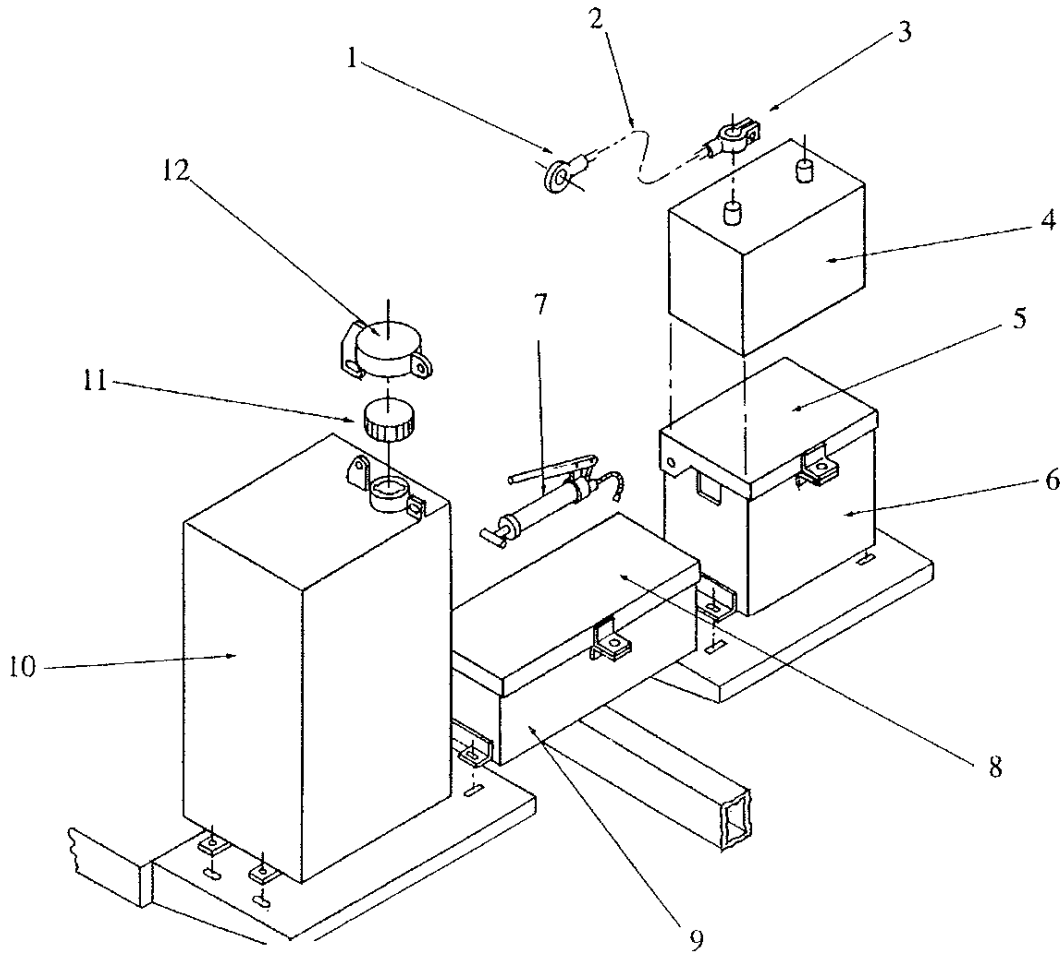

Item #	Description	Part #	Qty.
1	Eyelet, Cable	0315059	2
2	Cable, Battery	0315057	2
3	Top Post Terminal	0315058	2
4	Battery	0315060	1
5	Cover, Battery Box	0271020	1
6	Battery Box	0280001	1
7	Grease Gun, Optional	0369004	1
8	Cover, Tool Box	0271021	1
9	Tool Box	0280028	1
10	Tank, Diesel	0252057	1
11	Cap with Dipstick	0218004	1
12	Cap, Locking	0271024	1

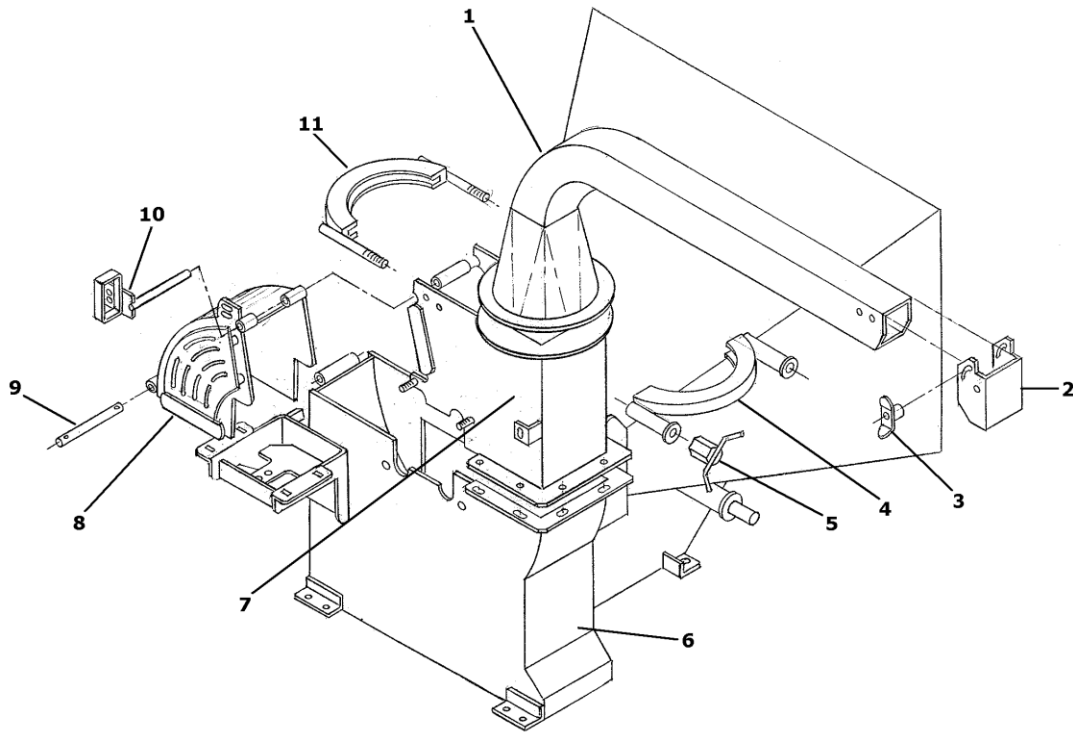

Item #	Description	Part #	Qty.
1	Discharge Chute	0226031	1
2	Chute Deflector	0426028	1
3	Wing Nut	0238500	1
4	Clamp, Front Half	0210067	1
5	Wing Nut, Chute Clamp	0238501	2
6	Housing, Impeller, Lower	0228128	1
7	Housing, Impeller, Upper (Fixed)	0228129	1
8	Housing, Impeller, Upper (Movable)	0228130	1
9	Hinge Pin, Lower Housing	0440050	1
10	Pin, Locking	0240051	1
11	Clamp, Rear Half	0210168	1

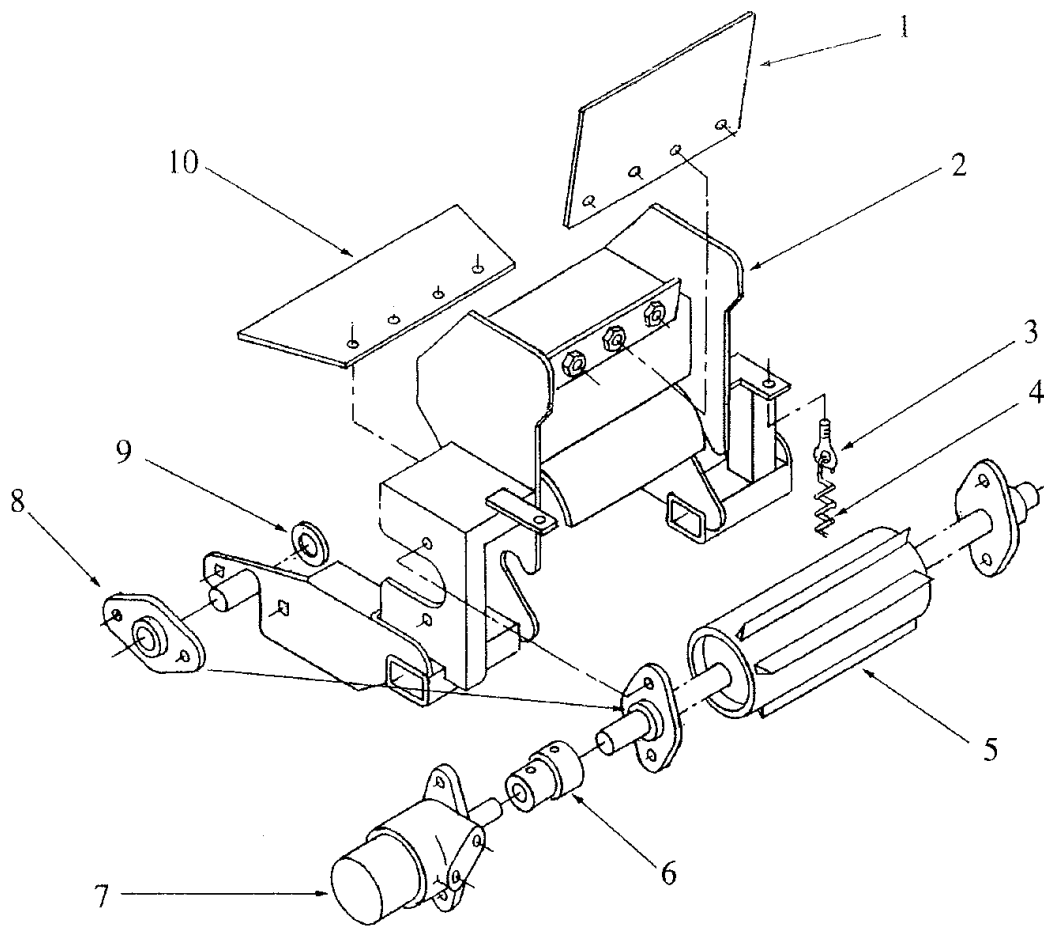

Item #	Description	Part #	Qty.
1	Guard, Upper Flap	0421073	1
2	Frame, Power Feed	0219069	1
3	Eye Bolt	0346860	2
4	Spring, Extension	0350018	2
5	Power Feed Roll	0254043	1
6	Coupling, Power Feed Roll	0213062	1
7	Hydraulic Drive Motor	0330140	1
8	Bearing, 2-Bolt Flanged	0303031	4
9	Flat Washer	0353120	2
10	Guard, Lower Flap	0421074	1

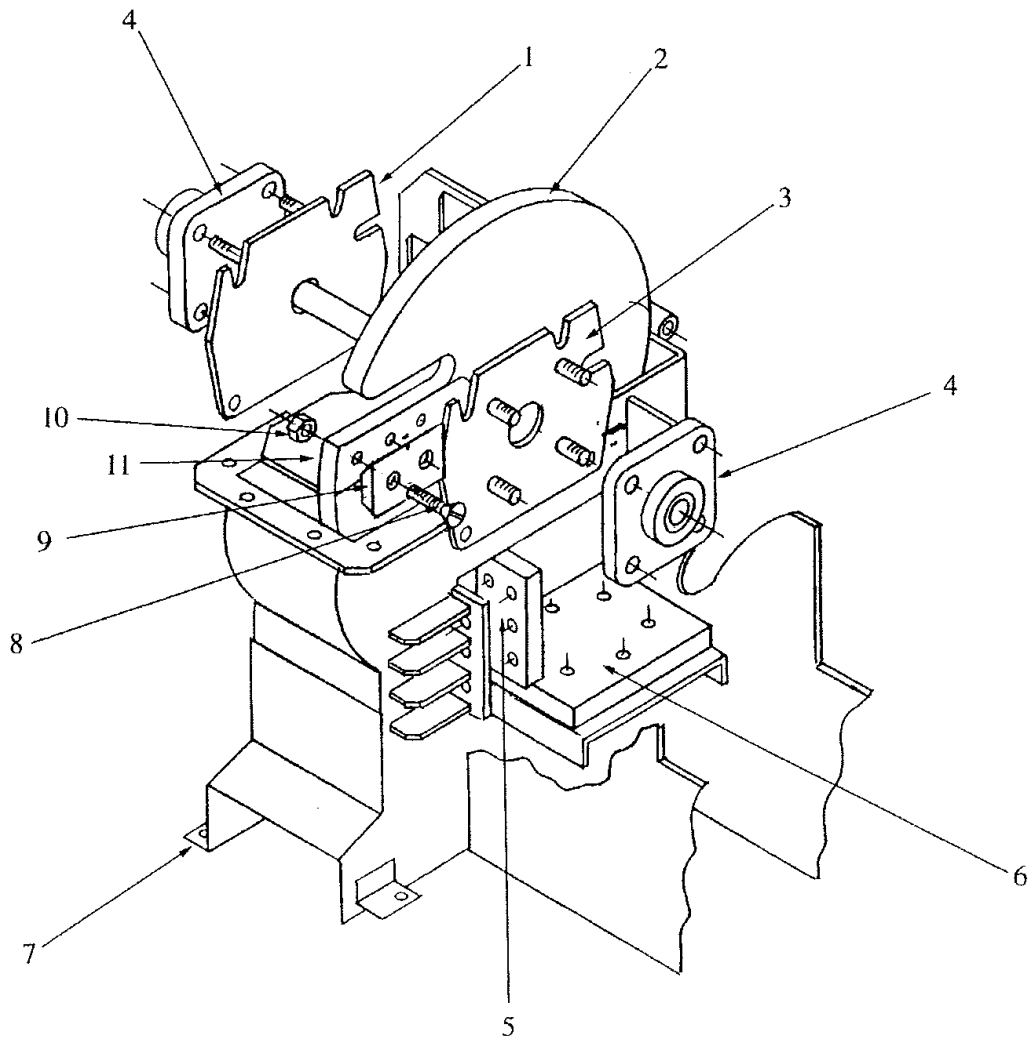

Item #	Description	Part #	Qty.
1	Plate, Bearing Mtg. Front	0241654	1
2	Shaft/Impeller Assembly	0248182	1
3	Plate, Bearing Mtg. Rear	0241655	1
4	Bearing, 4-Bolt Flanged	0303032	2
5	Bed Knife, Vertical	0441582	1
6	Bed Knife, Horizontal	0441581	1
7	Housing, Impeller, Lower	0228128	1
8	Flat Head Screw	0346487	8
9	Blade, Chip	0305090	4
10	Stover Nut	0338154	8
11	Washer	0353017	8

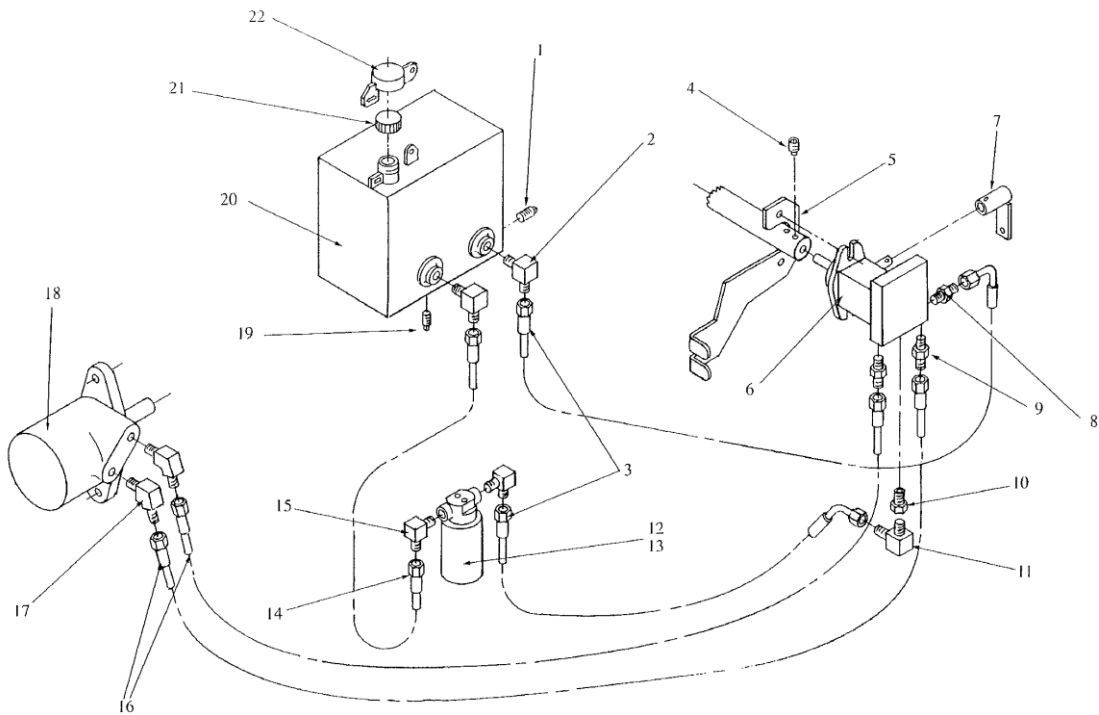

Item #	Description	Part #	Qty.
1	Plug	0317107	1
2	Adapter, 90°	0317052	2
3	Hose, Hydraulic	0327028	2
4	Set Screw	0346276	2
5	Bracket, Hydraulic Pump Mtg.	0406405	1
6	Pump, Hydraulic	0330021	1
7	Lever, Hydraulic Pump	0233075	1
8	Adapter, Straight	0317066	1
9	Adapter, Straight	0317030	1
10	Adapter, Bushing	0317058	1
11	Adapter, 90°	0317069	1
12	Filter, Hydraulic with Housing	0318022	1
13	Filter, Hydraulic	0318023	1
14	Hose, Hydraulic	0327076	1
15	Adapter, 90°	0317040	2
16	Hose, Hydraulic	0327115	2
17	Adapter, 45°	0317098	2
18	Drive Motor, Hydraulic	0330140	1
19	Plug, Oil Drain	0317070	1
20	Tank, Hydraulic Oil	0252012	1
21	Cap with Dip Stick	0371061	1
22	Cap, Locking	0271024	1

Below is a quick reference chart for various “Flat Head Cap Screws” and the torque recommendations.

VALUES ARE STATED IN FOOT POUNDS

BOLT SIZE	Thds Per Inch	SAE Grade 5	SAE Grade 8
1/4	20	10	14
	28	---	---
5/16	18	19	29
	24	---	---
3/8	16	33	47
	24	---	---
7/16	14	54	78
	20	---	---
1/2	13	78	119
	20	---	---
9/16	12	114	169
	18	---	---
5/8	11	154	230
	11	---	---
3/4	10	257	380
	10	---	---
7/8	9	382	600
	9	---	---
1	8	587	700
	8	---	---

Drive Belt Tension Measurement by Deflection

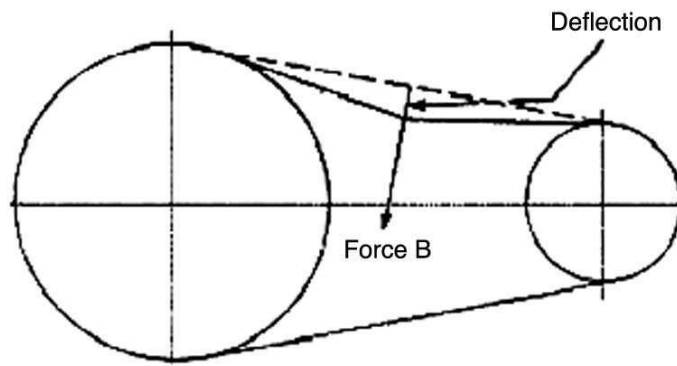

Deflection should be 3/8" when 8-12 lbs. push is applied at "B"

WARRANTY POLICY

Please remember to complete and return your Warranty Card and Dealer Delivery Report. Warranty Claims will not be considered if the Warranty Card and Dealer Delivery Report have not been returned to Salsco.

Your Salsco Commercial or Turf Equipment product is a commercial type product and is normally manufactured and sold for commercial or industrial use. **Salsco will, for the original purchaser, for one (1) year from the date of purchase (90 days if used for rental purposes) repair or replace, free of charge, any SALSCO part or parts found to be defective in material, workmanship or both.** Any transportation or shipping charges will be borne by the purchaser. If, during the warranty period stated above, the product does not function properly due to defect, simply contact Salsco and follow the Warranty Procedures included in this manual.

This warranty **does not** include:

- Incidental or consequential damages and is exclusive of any implied warranties.
- Normal maintenance parts, including, but not limited to hoses, chains, belts, filters, lubricants, etc.
- Parts or components, which are covered under the original manufacturer warranty, including, but not limited to engines, pumps, and motors.

WARRANTY PROCEDURE

In order for Salsco to consider your warranty claims in a timely manner you must follow the simple procedures listed below:

MACHINE OR PART FAILURE

- Call our service department for helpful instruction on how to correct or repair the problem. Preventive maintenance will also be suggested.
- When ordering parts for Warranty issues, you **MUST** retain possession of the old parts in question until notified with respect to returning the parts to Salsco or other disposition.
- Warranty Claims **MUST** be filed within 30-days from completion of the work performed. Contact our office for an electronic warranty claim form.
- Fill in all information requested on warranty claim form, a copy of which is included in this manual, (date of purchase, company name, address, etc.). List all parts used. Make sure part numbers are correct. You can obtain these from your manual. (include good description of problem; i.e. "leaking from spool" rather than "leaking").
- It is our goal to consider and reach a disposition on each Warranty Claim within 30-days from the date that it is received. Therefore it is important that you respond promptly to any request for further information. Claims with no response to inquiries will be closed as "**denied for lack of response**" 90-days from the date of request.
- Email, Fax or Send Warranty Claim form to our Warranty Department. – **Warranty on parts most often requires return of the parts that were replaced. DO NOT DISCARD OLD PARTS UNTIL YOU HAVE RECEIVED A DETERMINATION AS TO WHETHER THESE PARTS MUST BE RETURNED.**
- Our Warranty Department will contact and instruct you on how to return the Parts to Salsco on an RA #. Returns **MUST** be made within 30-Days from issuance of RA #. **FREIGHT CHARGES ON RETURN OF PARTS IS THE RESPONSIBILITY OF THE CUSTOMER.** Normal pre-delivery adjustments are not covered under warranty. Labor Warranties are based on reasonable time allowances as determined by Salsco, Inc. and paid at 75% of posted labor rate. **TRAVEL TIME IS NOT REIMBURSED UNDER THE WARRANTY POLICY.**
- Be sure to put the RA form inside the box that you are shipping back, also be sure to put on the outside of the box "Return of Goods" and the RA #.
- Ship returns via a traceable method such as UPS Ground Service. Be sure that the shipment is insured for the appropriate value. If uninsured parts are lost, we cannot issue a credit.

PLEASE NOTE: *Warranty forms should be filled out completely.*

PREVENTIVE MAINTENANCE IS YOUR BEST INSURANCE AGAINST EQUIPMENT FAILURE. BE SURE TO READ THIS MANUAL, ESPECIALLY THE MAINTENANCE, OPERATING AND CAUTION SECTIONS.

SALSCO, INC., 105 School House Rd.
Cheshire, CT 06410
800-872-5726, 203-271-1682
203-271-2596 (Fax)
sales@salsco.com, www.salsco.com

SALESMAN ID # _____

SALES MANAGER'S NAME _____

800-872-5726, 203-271-1682 203-271-2596 (Fax)	SALSCO, INC. 105 School House Road Cheshire, CT 06410	www.salsco.com sales@salsco.com
DEALER DELIVERY REPORT		
MODEL: _____	SERIAL NO: _____	
DEALER: _____	CITY: _____	STATE: _____ ZIP: _____
PURCHASER: _____	ADDRESS: _____	CITY: _____ ST: _____ ZIP: _____
<p>The undersigned dealer warrants that the above-described machine was carefully inspected, adjusted and prepared for delivery before delivery to the purchaser; that both the operation and maintenance of the machine were explained to the purchaser; and that a copy of the Owner's Instruction Manual were given to the purchaser and his attention called to Our Warranty and any operating instructions included in the manual and caution notes.</p>		<p>The undersigned purchaser certifies that the operation and maintenance of the above-described machine have been explained to him; acknowledges receipt of a copy of the Owner's Instruction Manual and Our Warranty Policy printed in said Instruction Manual and Caution Notes. I also understand that it is my responsibility to explain and make Salsco manuals available to new operators.</p>
DATE: _____	DATE: _____	PURCHASER: _____
SIGN BY: _____	SIGN BY: _____	
PHONE: _____	FAXI _____	PHONE: _____
E-Mail _____	EMAIL: _____	

MODEL: _____	SERIAL NO: _____	
SALSCO LIMITED WARRANTY CARD		
DATE PURCHASED: _____		
PURCHASER: _____	ADDRESS: _____	CITY: _____ ST: _____ ZIP: _____
EMAIL: _____	PHONE: _____	
DEALER: _____	STATE: CT	
Will this equipment be used commercially?	Yes <input type="checkbox"/>	No <input type="checkbox"/>
Did Dealer service this equipment and instruct you in its care and safe operation?	Yes <input type="checkbox"/>	No <input type="checkbox"/>
Did you receive an "Operation & Service Manual" and safety pamphlet?	Yes <input type="checkbox"/>	No <input type="checkbox"/>
Signed _____		Purchaser _____
NOTICE:	IMPORTANT: THIS CARD MUST BE FILLED OUT COMPLETELY AND MAILED TO THE FACTORY WITHIN 10 DAYS OF PURCHASE DATE, OR YOUR LIMITED WARRANTY WILL BE VOIDED.	

