

**OPERATORS AND PARTS MANUAL
MODEL 824 P.T.O., WOOD/BRUSH CHIPPER**



MANUFACTURER OF OUTDOOR POWER EQUIPMENT

Products for Turf & Lawn care, Rental, Construction, Tree care, Wood Processing, Nursery & Farm Industries

Other Salsco Equipment

3-1/2" - 18", Gas, Diesel, and P.T.O, Wood/Brush Chippers

Chipper Shredder Vacuum - Tailgate & Truckloader Vacuums up to 65 HP

Shaving Mills - Gas and Electric Greens Rollers

***Quality of Workmanship, Innovative
Design, Built to Last!***

105 School House Road
Cheshire, CT 06410 U.S.A.
800-872-5726, 203-271-1682, 203-271-2596 (Fax)
sales@salsco.com, www.salsco.com

TABLE OF CONTENTS

MODEL 824 P. T. O. DESCRIPTION

COVER & TABLE OF CONTENTS.....Pages 1 – 2

STATEMENT OF FACT Page 3

SPECIFICATIONS & FEATURESPage 4

MACHINE REGISTRATIONPage 5

SAFETY & OPERATING INSTRUCTIONSPages 6 - 9

SERVICE & MAINTENANCE INSTRUCTIONSPage 10

PARTS DIAGRAMSPages 11 – 17

HOW TO CUT A DRIVE SHAFTPage 18

TORQUE CHARTSPage 19

WARRANTY POLICY/PROCEDUREPage 20

COPY OF WARRANTY CLAIM FORM.....Page 21

COPY OF DEALER DELIVERY REPORT & WARRANTY CARD.....Page 22

SERVICE SCHEDULE LOGPage 23

SALSCO, INC.
105 School House Road
Cheshire, CT 06410
800-872-5726, 203-271-1682
203-271-2596 (Fax)
www.salco.com sales@salco.com

STATEMENT OF FACT

You have just purchased the highest quality, most dependable, 824 P.T. O. Chipper, on the market today. This unit has the ability to meet exact standards and perform for years with minimum downtime. **HOWEVER**, it cannot read nor will it understand this manual no matter how long you leave it on top of the machine.

It is your responsibility to read and understand this manual; it is also your responsibility to be certain this information is passed along to anyone who is expected to operate this equipment. Should you choose not to read, understand and pass along the information provided you, please expect equipment failure and possible injuries to persons around this equipment.

For the safety of the operator, it is **imperative** that this manual is carefully read and understood.

Once you have read this manual, it is your responsibility to be sure that all new operators read and understand this manual, especially all cautions stated.

As a manufacturer of equipment, we have a responsibility to design a safe piece of equipment. **NOTE:** The important safeguards and instructions in this manual are not meant to cover all possible conditions and situations that may occur. It must be understood that common sense, caution, and care are factors, which cannot be built into any product. These factors must be supplied by the person(s) caring for and operating this equipment.

ONLY YOU CAN PREVENT ACCIDENTS!!

SPECIFICATIONS & FEATURES

The Salsco Model 824 Chipper, like all of Salsco products, is ruggedly built to withstand high volume usage by the golf course; farmer, homeowner and tree care industries. The drive shaft and power feed are also standard equipment. This machine only needs to connect to a power take off of 540 R.P.M. and at least 15 HP to operate. The complete hydraulic system is self-contained to operate the hydraulic power feed. Orange polyester powder coat paint offers protection against ultra violet discoloration, outdoor weatherability and resists most chemicals.

Model 824 has an in feed opening of 4" x 8" to eliminate most pruning of limbs. It will handle Christmas trees, palm fronds, vines and leafy material, with ease. Two bed knives assure the cutting of smaller diameter material into short more desirable pieces. To prevent material such as palm fronds and vines from wrapping around the feed roll, this unit comes equipped with both a vertical and horizontal bed knife. In addition, we have welded in scraper bars, which clean excess material off the roll. Our standard feed roll has welded blades and it measures 7" in diameter by 8" long. Speed of the hydraulic feed is easily adjusted at the hydraulic pump and can be controlled by the control bar positioned at the top of the chipper chute to forward/off/reverse. The chipper disc is 3/4" thick by 18-7/8" diameter and mounted on a 1" diameter steel shaft with six exhaust blades.

Simple and safe operation, easy to maintain, and built to last;
Salsco, Model 824, 4" x 8" 3-Point Hitch Chipper!

MACHINE REGISTRATION

MANUFACTURED BY: SALSCO, INC.
105 School House Rd., Cheshire, CT 06410
800-872-5726, 203-271-1682, 203-271-2596 (Fax)
sales@salsco.com www.salsco.com

THIS MANUAL COVERS MODEL (s): 824PTO, 4" x 8" 3-POINT HITCH CHIPPER

This company reserves the right to discontinue, add improvements to, or change the design of any model or product at any time without obligation to improve existing machines, either by changing the design or adding new parts.

It has been and will continue to be the policy of SALSCO to update existing machines at its own discretion. Whenever possible, new designs will be made in such a way that they can be "Retro Fit" if so desired.

Record in the space provided below the model and serial number of this unit. Please retain these numbers for future reference.

No parts orders will be accepted **WITHOUT MODEL NUMBERS OR PART NUMBERS**. All part numbers are listed in this manual.

Serial Number

Model Number

NOTE: Be sure to complete your warranty card. This will insure immediate processing of any warranty claims.

READ AND UNDERSTAND THIS MANUAL BEFORE STARTING THE MACHINE

1/06

CAUTIONS

READ THOROUGHLY THE OPERATOR SAFETY INSTRUCTIONS ON THE FOLLOWING THREE PAGES, WHICH ARE THE AMERICAN NATIONAL STANDARD OF POWERED SHREDDERS/GRINDERS, SAFETY SPECIFICATIONS PROVIDED BY ANSI AND THE O.P.E.I.

THE FOLLOWING CAUTIONS ARE PROVIDED BY SALSCO AS A QUICK REFERENCE ONLY AND ARE NOT MEANT TO REPLACE THE PRECAUTIONS ON THE FOLLOWING PAGES.

1. **ALWAYS** use protective eyewear when machine is in operation.
2. **ALWAYS** use gloves and wear ear protection when machine is in operation.
3. **NEVER** put hands, legs or any part of your body into or near Chipper intake or discharge openings.
4. **NEVER** run machine with guards or shaft cover removed.
5. **ALWAYS** allow machine to cool off, **BE SURE** machine has stopped completely, and disconnect drive shaft from tractor before attempting any maintenance, or repair.
6. **NEVER** stand in front of chipper infeed hopper. It is possible for a chip or piece of wood to be thrown out.
7. **BE SURE** the machine and tractor is parked on a dry level surface before starting operation.
8. **DO NOT** operate with loose clothing or long unrestrained hair. Be sure vines and branches are not wrapped around your body parts.
9. **DO NOT** operate on ice or any other slippery surface. Be sure area around machine is clear and clean. You do not want to trip into the machine.
10. **NEVER** leave machine running unattended, especially around youngsters or persons not instructed in the safe operation of this machine.
11. **READ** and understand federal guidelines provided with this manual.

NEVER run machine without connecting the 3-point to the tractor!

BRUSH CHIPPERS
ANSI Z133.1-2006
American National Standard for Arboricultural Operations
Safety Requirements

5.3 Brush Chippers

- 5.3.1 The items contained in section 5.1 shall always be included in the review of this section.
- 5.3.2 Access panels (for example, guards) for maintenance and adjustment, including discharge chute and cutter housing, shall be closed and secured prior to starting the engine of brush chippers. These access panels shall not be opened or unsecured until the engine and all moving parts have come to a complete stop (see Annex C, General Safety Procedures That Apply to All Tree Work).
- 5.3.3 Rotary drum or disc brush chippers not equipped with a mechanical infeed system shall be equipped with an infeed hopper not less than 85 inches (2.15 m) measured from the blades or knives to ground level over the center line of the hopper. Side members of the infeed hopper shall have sufficient height so as to prevent workers from contacting the blades or knives during operations.
- 5.3.4 Rotary drum or disc brush chippers not equipped with a mechanical infeed system shall have a flexible anti-kickback device installed in the infeed hopper to reduce the risk of injury from flying chips and debris.
- 5.3.5 Chippers equipped with a mechanical infeed system shall have a quick-stop and reversing device on the infeed system. The activating mechanism for the quick-stop and reversing device shall be located across the top, along each side, and close to the feed end of the infeed hopper within easy reach of the worker.
- 5.3.6 Vision, hearing, and/or other appropriate personal protective equipment shall be worn when in the immediate area of a brush chipper in accordance with section 3.4, Personal Protective Equipment.
- 5.3.7 Arborists, mechanics, and other workers shall not, under any circumstances, reach into the infeed hopper when the cutter disc, rotary drum, or feed rollers are moving.
- 5.3.8 When trailer chippers are detached from the vehicles, they shall be chocked or otherwise secured in place.
- 5.3.9 When in a towing position, chipper safety chains shall be crossed under the tongue of the chipper and properly affixed to the towing vehicle.
- 5.3.10 See section 8.6, Brush Removal and Chipping, for additional requirements.

BRUSH REMOVAL AND CHIPPING
ANSI Z133.1-2006
American National Standard for Arboricultural Operations
Safety Requirements

8.6 Brush Removal and Chipping

- 8.6.1 Traffic control around the jobsite shall be established prior to the start of chipping operations along roads and highways (see section 3.2, Traffic Control Around the Jobsite).
- 8.6.2 Brush and logs shall not be allowed to create hazards in the work areas.
- 8.6.3 To prevent an entanglement hazard, loose clothing, climbing equipment, body belts, harnesses, lanyards, or gauntlet-type gloves (for example, long-cuffed lineman's or welder's gloves) shall not be worn while operating chippers.
- 8.6.4 Personal protective equipment shall be worn when in the immediate area of chipping operations in accordance with section 3.4, Personal Protective Equipment, of this standard.
- 8.6.5 Training shall be provided in the proper operation, feeding, starting, and shutdown procedures for the chipper being used.
- 8.6.6 Maintenance shall be performed only by those persons authorized by the employer and trained to perform such operations.
- 8.6.7 Brush and logs shall be fed into chippers, butt or cut end first, from the side of the feed table center line, and the operator shall immediately turn away from the feed table when the brush is taken into the rotor or feed rollers. Chippers should be fed from the curb-side whenever practical.
- 8.6.8 The brush chipper discharge chute or cutter housing cover shall not be raised or removed while any part of the chipper is turning or moving. Chippers shall not be used unless a discharge chute of sufficient length or design is provided that prevents personal contact with the blades (see Annex C, General Safety Procedures That Apply to All Tree Work).
- 8.6.9 Foreign material, such as stones, nails, sweepings, and rakings, shall not be fed into chippers.
- 8.6.10 Small branches shall be fed into chippers with longer branches or by being pushed with a long stick.
- 8.6.11 Hands or other parts of the body shall not be placed into the infeed hopper. Leaning into or pushing material into infeed hoppers with feet is prohibited.
- 8.6.12 While material is being fed into the chipper infeed hopper chute, pinch points continually develop within the material being chipped and between the material and machine. The operator shall be aware of this situation and respond accordingly.
- 8.6.13 When feeding a chipper during roadside operations, the operator shall do so in a manner that prevents him or her from stepping into traffic or being pushed into traffic by the material that is being fed into the chipper.
- 8.6.14 When using a winch in chipper operations, the operator shall ensure that the winch cable is properly stored before initiating chipper operations.
- 8.6.15 Refer to section 5.3, Brush Chippers, for additional information.

OPERATING INSTRUCTIONS

- 1) Be sure all guards and covers are in place.
- 2) Check all chambers to be sure they are free and clear of debris.
- 3) Set direction of discharge chute and TIGHTEN in Position.
- 4) Set feed handle in neutral position.
- 5) Set machine on ground and engage PTO slowly.
- 6) Bring tractor up to R.P.M. to give the PTO shaft 540 R.P.M.
- 7) Be sure to set tractor brakes.
- 8) Engage feed handle. NOTE: You will notice the more you pull the handle towards the rear of the machine, the faster the roll turns and when you push in the other direction the roll slows down.
- 9) With the feed roll turning slowly, place the first branch on the infeed table. NOTE: You should be standing, looking at the infeed hopper opening, as you place the branch in the feed roll. Turn to your left and exit the area. Go and get another branch, do not worry about the chipper, it will take care of itself. Should there be any wood left on the infeed tray, it will be taken care of by the next branch. **DO NOT REACH INTO THIS MACHINE FOR ANY REASON!**
- 10) When you are done chipping, close the infeed door and let the machine come down to an idle for a few minutes before shutting down.
- 11) After shut down and you are sure the impeller has stopped turning, disconnect the drive shaft.
- 12) With the drive shaft disconnected, clean any leftover debris from the infeed area. This would be a good time to clean the rest of the machine.

HINTS

- 1) When operating machine, stand off to the side of the feed hopper when feeding wood into the machine. **NEVER STAND DIRECTLY IN FRONT OF THE FEED HOPPER WHEN FEEDING WOOD INTO THE MACHINE.**
- 2) When using the chipper and you have a short piece of wood bouncing around and not being grabbed by the feed roll, **LEAVE IT! DO NOT TRY TO PUSH IT THROUGH WITH ARMS OR LEGS!** The next limb will push it through.
- 3) When through with the job, make sure all material has run through the machine before shutting it down. This will prevent any injuries from flying debris when the machine is started up at the next job.

REMEMBER! A CHIPPER WILL ONLY LET YOU MAKE A STUPID MISTAKE ONCE!

SERVICE SCHEDULE

1. **Grease** all main bearings once a day. **DO NOT OVER GREASE.** Wipe extra grease off bearings.
2. Be sure to **clean** entire machine. Should it become necessary to remove the exhaust chute, either to sharpen the blades or to clean out the machine, **DISCONNECT DRIVE SHAFT FROM TRACTOR. NEVER RUN UNIT WHILE EXHAUST CHUTE IS REMOVED.**
3. **Sharpen/change chipper blades: Disconnect drive shaft.** Pull locking pin from impeller housing and open housing. **DO NOT** reach in and hold the impeller with your hand, instead use a piece of wood to push impeller. Remove blades and reverse or replace with sharpened ones. **It is recommended** that you replace the hardware whenever replacing or reversing the blades. **Be sure** to follow the torque specifications in this manual. **Be sure** to clean mounting surface before installing the blades, and be sure to use Loctite when replacing bolts. We use Loctite Blue 242 when installing blades at the factory. (Note: Salsco has a Blade Sharpening Service)
4. **Bed knife adjustment** on hydraulic feed machines is .070.
HINT: It is strongly recommended to have a set of blades and screws on the shelf, to prevent downtime while blades are being sharpened. **HINT:** Blades need sharpening after approximately 8 - 15 hours of use.
5. It has been determined that your Chipper will perform better using a 25 micron filter and hydraulic oil Mobil DTE 26 or Citgo HYD 68 or either ones equivalent. The oil should have a viscosity rating of at least 100 VSU. While this is not a necessity, it will improve the over all performance of these units and is recommended by Salsco.

| SERVICE SCHEDULE | AS NEEDED | DAILY | WEEKLY | MONTHLY |
|----------------------------|-----------|-------|--------|---------|
| CLEAN MACHINE | X | X | | |
| GREASE INFEED ROLL BEARING | X | X | | |
| GREASE DISC SHAFT BEARING | X | X | | |
| SHARPEN CHIPPER BLADES | X OR | | X | |
| CHECK & ADJUST BED KNIFE | X OR | | X | |
| CHECK ALL NUTS & BOLTS | X | X | | |
| CHECK HYDRAULIC OIL | X | | | X |
| CHECK HYDRAULIC HOSES | X | | | X |

NEVER, UNDER ANY CIRCUMSTANCES START THE ENGINE WHEN UNIT IS OPEN OR AT ANY TIME DURING SERVICE OR ROUTINE MAINTENANCE

DRAWING # 1

| ITEM # | DESCRIPTION | PART # | QTY. |
|--------|--------------------------|---------|------|
| 1 | Chute, Exhaust | 0226129 | 1 |
| 2 | Chute, Exhaust Deflector | 0426131 | 1 |
| 3 | Wing Nut | 0238500 | 1 |
| 3A | Carriage Bolt | 0346230 | 1 |
| 3B | Flat Washer | 0353181 | 1 |
| 3C | Lock Washer | 0353015 | 1 |
| 4 | Clamp, Exhaust Chute | 0210123 | 1 |
| 5 | Housing, Impeller, Upper | 0228223 | 1 |
| 6 | Pin, Housing Locking | 0240095 | 1 |
| 7 | Mount, Impeller Bearing | 0276422 | 1 |
| 8 | Housing, Impeller, Lower | 0228221 | 1 |
| 9 | Pin, Housing Hinge | 0440097 | 1 |
| 10 | Housing, Impeller Upper | 0228224 | 1 |
| 11 | Mount, Impeller Bearing | 0276523 | 1 |
| 12 | Wing Nut, 1/2-13 | 0238504 | 2 |
| 13 | Clamp, Exhaust Chute | 0210124 | 1 |
| 14 | Rubber Strip | 0356045 | 2 |

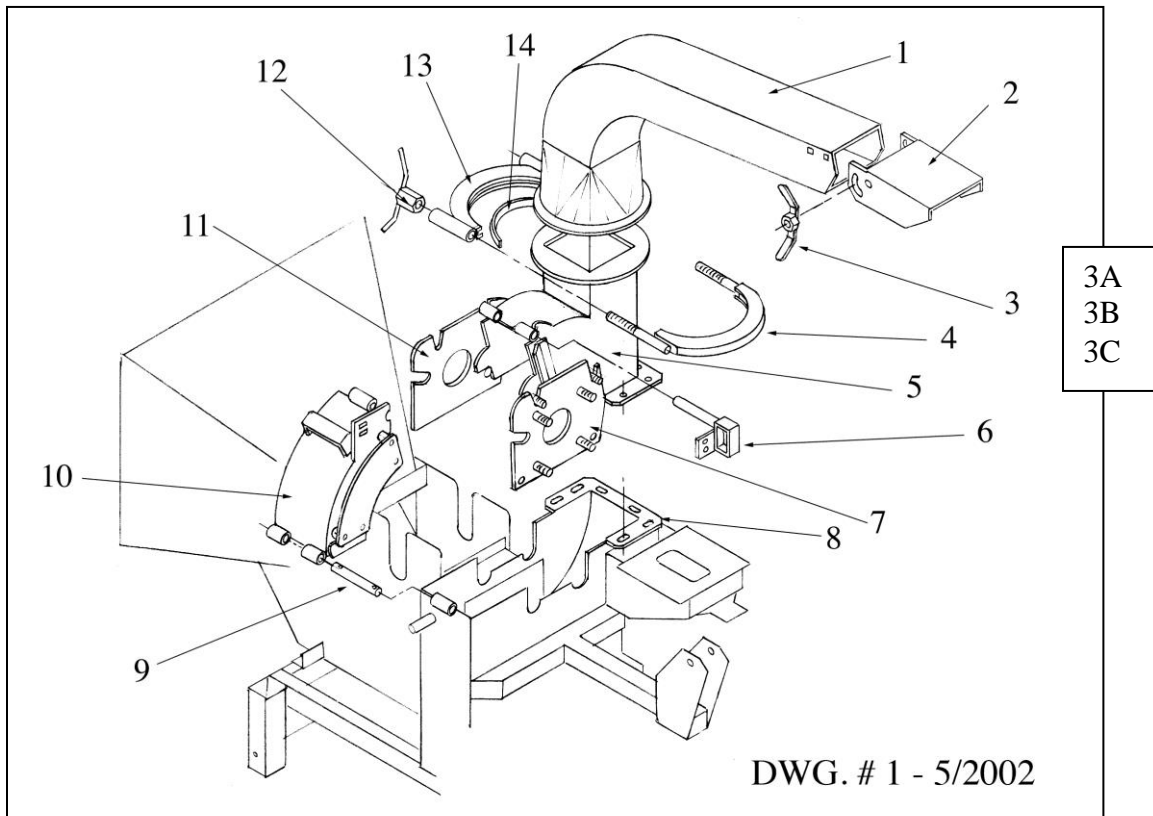

DRAWING # 2

| ITEM # | DESCRIPTION | PART # | QTY. |
|--------|---------------------------------|---------|------|
| 1 | Handle, Power Feed | 0223106 | 1 |
| 2 | Spring, Compression With Washer | 0350019 | 1 |
| 3 | Yoke, Detent Bearing | 0274007 | 1 |
| 4 | Bearing, Ball | 0303034 | 1 |
| 5 | Guard, Hydraulic Pump Belt | 0221349 | 1 |
| 6 | Guard, Drive Belt | 0221351 | 1 |
| 7 | Bracket, Guard Mounting | 0206628 | 1 |
| 8 | Mount, Hydraulic Pump | 0476425 | 1 |
| 9 | Pump, Hydraulic | 0330021 | 1 |
| 10 | Lever, Hydraulic Pump | 0233150 | 1 |
| 11 | Support, Frame | 0277156 | 4 |
| 12 | Rod, Hydraulic Pump Actuator | 0245132 | 1 |
| 13 | Yoke, End Kit | 0374020 | 2 |
| 14 | Plate, Detent | 0462031 | 1 |

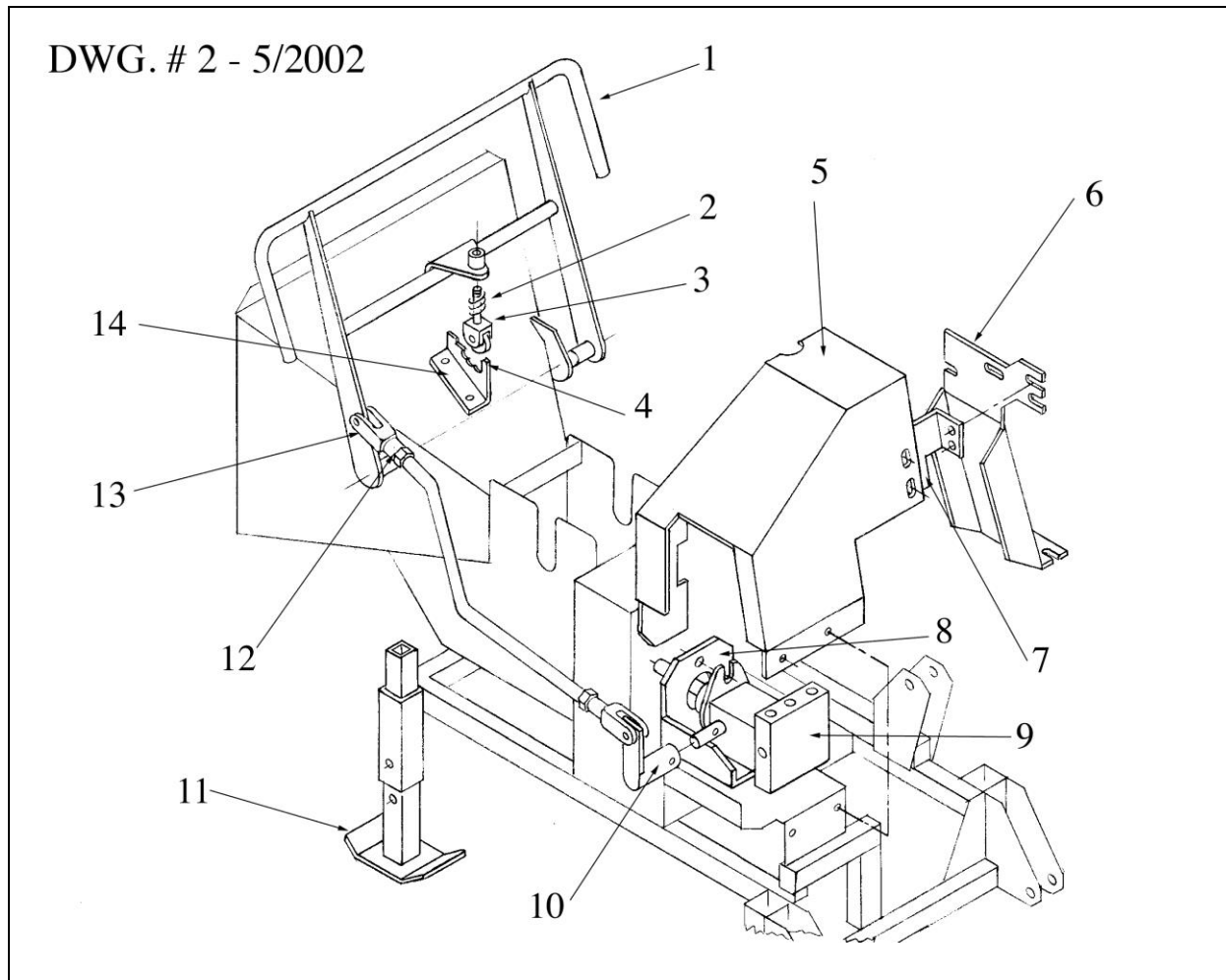

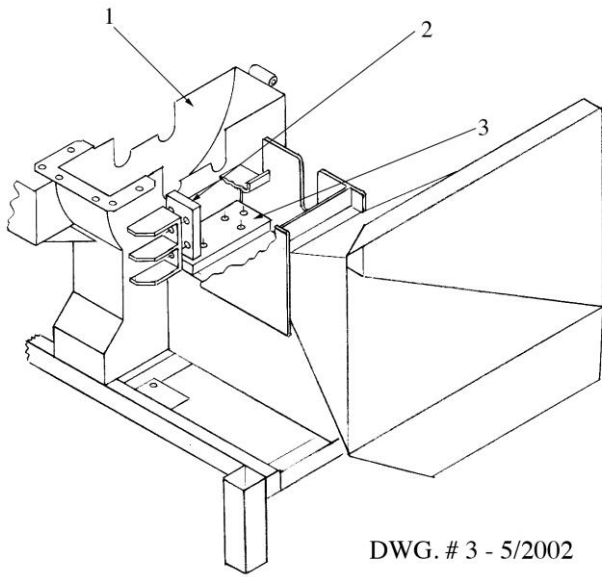

DWG. # 3 - 5/2002

DRAWING # 3

| # | DESCRIPTION | PART # | QTY. |
|---|------------------------------|---------|------|
| 1 | Housing, Impeller, Lower | 0228221 | 1 |
| 2 | Blade, Bed Knife, Vertical | 0405108 | 1 |
| 3 | Blade, Bed Knife, Horizontal | 0405107 | 1 |

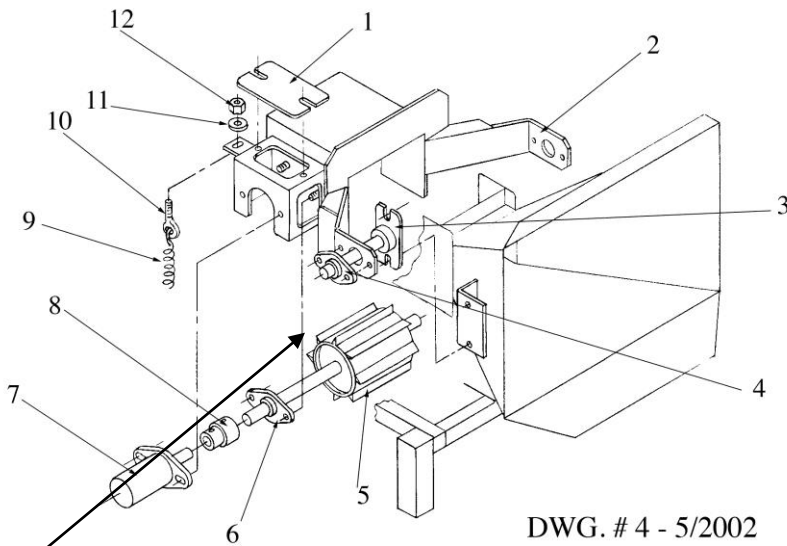

DWG. # 4 - 5/2002

Feed Arm Guard

REQUIRED HARDWARE
TO INSTALL FEED ARM
BACK PLATE GUARD:

QTY. 2 - 0338100
QTY. 2 - 0353121
QTY. 2 - 0353119
QTY. 2 - 0346070

DRAWING # 4

| ITEM # | DESCRIPTION | PART # | QTY. |
|--------|---|---------|------|
| 1 | Cover, Drive Motor Access | 0471209 | 1 |
| 2 | Yoke, Feed Roll | 0274028 | 1 |
| 3 | Post, Yoke Pivoting | 0278020 | 2 |
| 4 | Bearing, 2-Bolt, Flange | 0303006 | 2 |
| 5 | Wheel, Feed Roll | 0254087 | 1 |
| 6 | Bearing, 2-Bolt, Flange | 0303031 | 2 |
| 7 | Drive Motor, Hydraulic | 0330140 | 1 |
| 8 | Coupling, Power Feed Roll | 0213062 | 1 |
| 9 | Spring, Extension | 0350018 | 2 |
| 10 | Eye Bolt | 0346861 | 2 |
| 11 | Flat Washer | 0353113 | 4 |
| 12 | Hex Nut | 0338003 | 4 |
| | Infeed Door/Tray (Not pictured) | 0260038 | 1 |
| | Guard, Feed Arm Back Plate (Not pictured) | 0421387 | 1 |

DRAWING # 5

| ITEM # | DESCRIPTION | PART # | QTY. | <p>* NOTE THE FOLLOWING CHANGES TO MACHINES WITH S/N'S ENDING IN 1468 AND HIGHER:</p> <p>Item # 9, Sheave, P.T.O – 0342166 – Qty. 1</p> <p>Item # 13, V-Belt, Impeller – 0304103 – Qty. 3</p> <p>Item # 18, V-Belt, Pump – 0304022 – Qty. 1</p> |
|--------|----------------------------|---------------|------|--|
| 1 | Shaft, Impeller | 0248177 | 1 | |
| 2 | Chip Blade | 0305047 | 2 | |
| 3 | Flat Head Screw | 0346487 | 6 | |
| 4 | Lock Washer | 0353017 | 6 | |
| 5 | Stover Nut | 0338154 | 6 | |
| 6 | Sheave, Impeller to Pump | 0342085 | 1 | |
| 7 | Bushing, Impeller to Pump | 0342051 | 1 | |
| 8 | Bearing, Pillow Block | 0303033 | 2 | |
| 9 * | Sheave, P.T.O. | 0342140 | 1 | |
| 10 | Bushing, P.T.O. | 0342045 | 1 | |
| 11 | Shaft, P.T.O. Output | 0348192 | 1 | |
| 12 | Key, Standard | 3/8 X 3/8 X 2 | 4 | |
| 13 * | V-Belt, Impeller to P.T.O. | 0304082 | 3 | |
| 14 | Bushing, Impeller | 0342068 | 1 | |
| 15 | Sheave, Impeller | 0342070 | 1 | |
| 16 | Sheave, Pump | 0342086 | 1 | |
| 17 | Bushing, Pump | 0342067 | 1 | |
| 18 * | V-Belt, Pump | 0304015 | 1 | |
| 19 | Bearing, 4-Bolt, Flanged | 0303059 | 2 | |
| 20 | Hydraulic Pump | 0330021 | 1 | |

REV. 4/28/2011

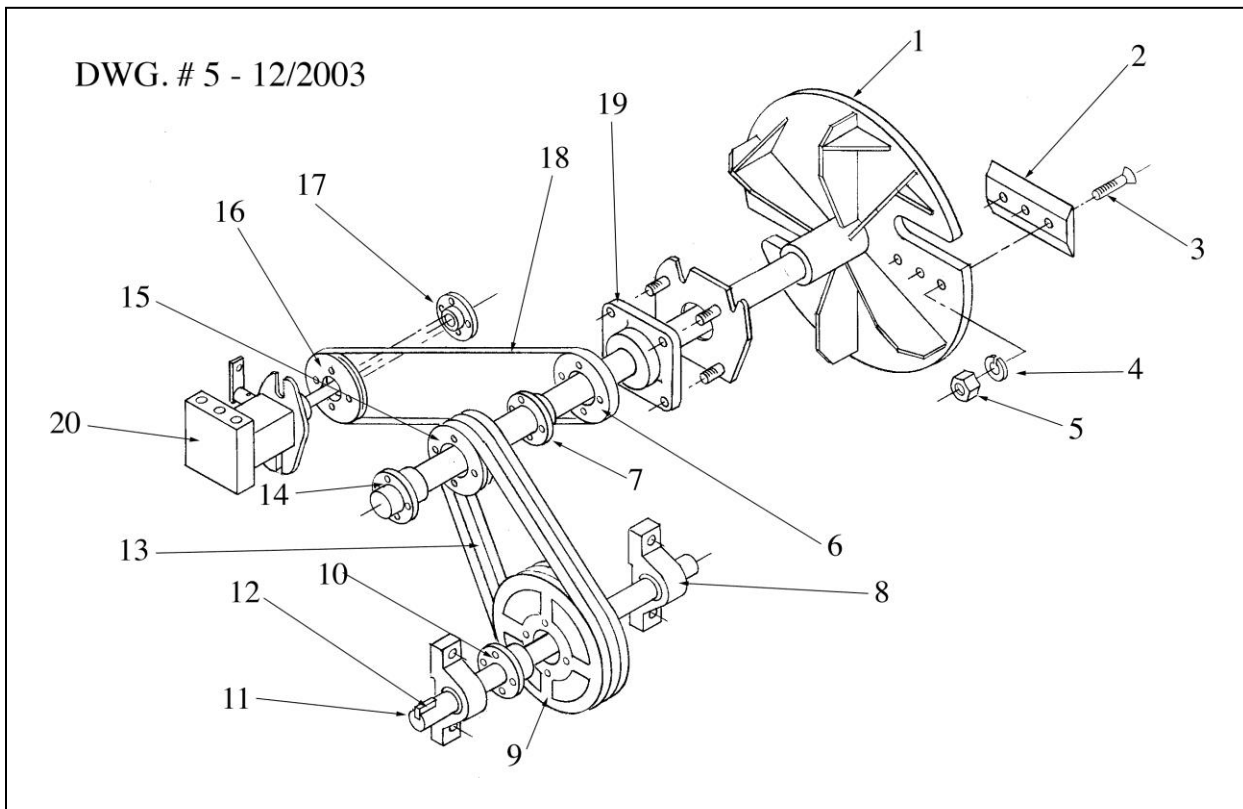

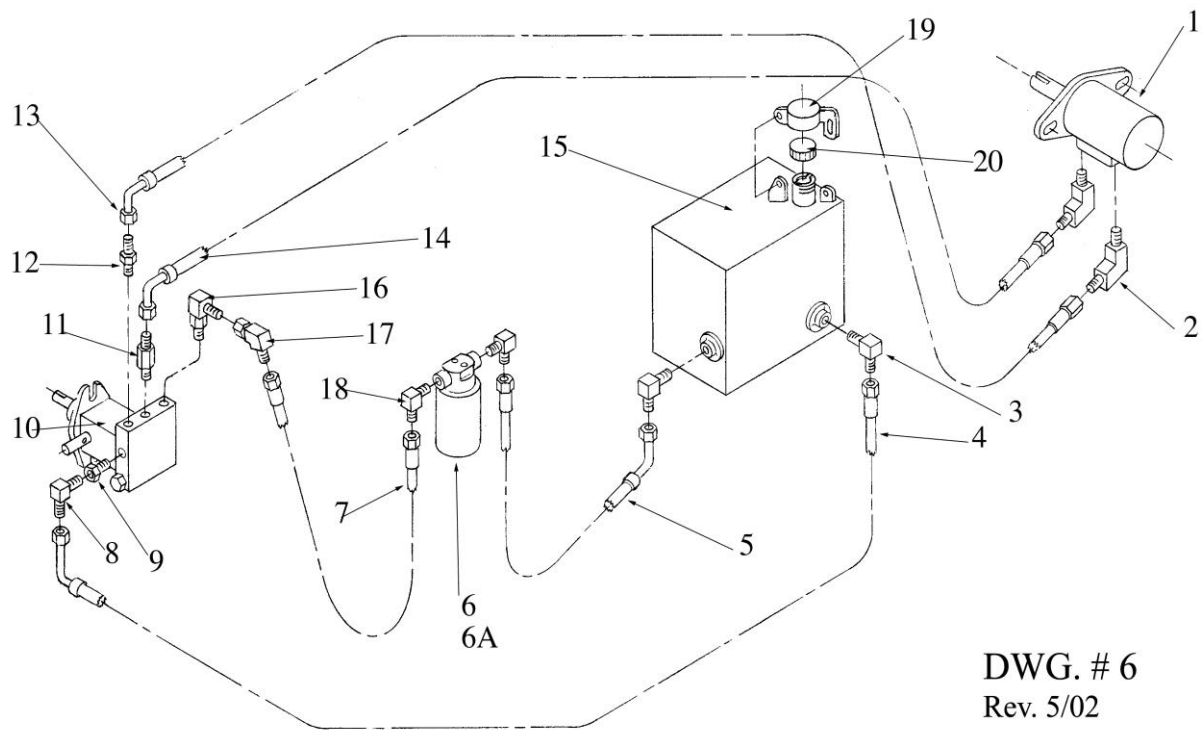

DWG. # 6
Rev. 5/02

DRAWING # 6

| EM # | DESCRIPTION | PART # | QTY | ITEM # | DESCRIPTION | PART # | QTY |
|------|----------------------|---------|-----|--------|---------------------|---------|-----|
| 1 | Drive Motor, Hyd | 0330140 | 1 | 11 | Adapter, O'Ring | 0317088 | 1 |
| 2 | Adapter, 45 Deg. | 0317098 | 2 | 12 | Adapter, Straight | 0317030 | 1 |
| 3 | Adapter, 90 Deg. | 0317052 | 2 | 13 | Hose, Pump to Motor | 0327153 | 1 |
| 4 | Hose, Pump to Tank | 0327178 | 1 | 14 | Hose, Motor to Pump | 0327179 | 1 |
| 5 | Hose, Tank to Filter | 0327176 | 1 | 15 | Tank, Hyd. Oil | 0252080 | 1 |
| 6 | Hyd. Filter & Hsg. | 0318022 | 1 | 16 | Adapter, 90 Deg. | 0317064 | 1 |
| 6A | Hyd. Filter | 0318023 | 1 | 17 | Adapter, 45 Deg. | 0317033 | 1 |
| 7 | Hose, Filter to Pump | 0327177 | 1 | 18 | Adapter, 90 Deg. | 0317040 | 2 |
| 8 | Adapter, 90 Deg. | 0317069 | 1 | 19 | Cap, Oil Fill Lock | 0271024 | 1 |
| 9 | Adapter, Bushing | 0317058 | 1 | 20 | Cap, Fuel Tank | 0371061 | 1 |
| 10 | Pump, Hyd. | 0330021 | 1 | | | | |

DWG. # 7

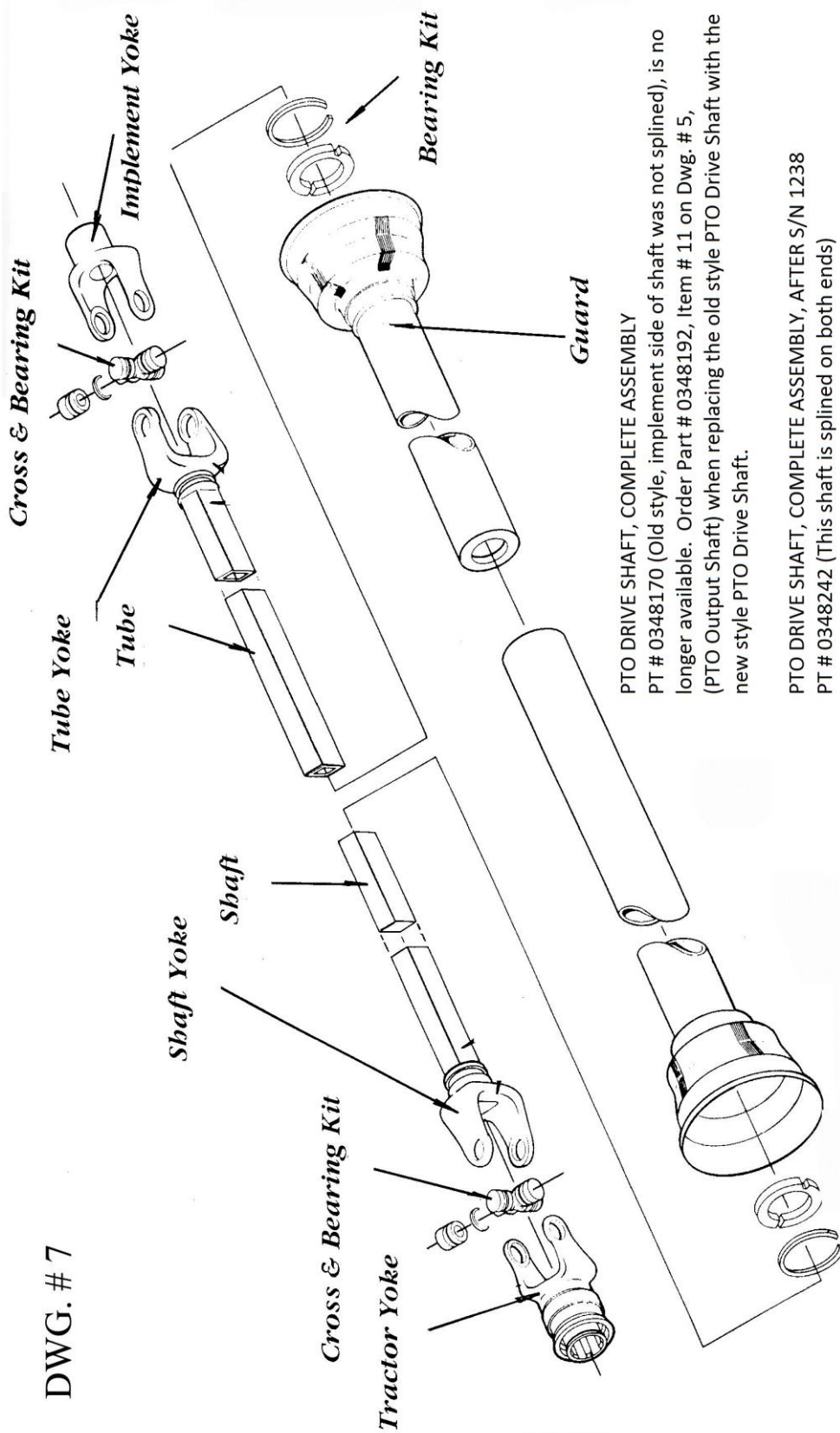

PTO DRIVE SHAFT, COMPLETE ASSEMBLY
PT # 0348170 (Old style, implement side of shaft was not splined), is no longer available. Order Part # 0348192, Item # 11 on Dwg. # 5, (PTO Output Shaft) when replacing the old style PTO Drive Shaft with the new style PTO Drive Shaft.

PTO DRIVE SHAFT, COMPLETE ASSEMBLY, AFTER S/N 1238
PT # 0348242 (This shaft is splined on both ends)

**HYDRAULIC SYSTEM WITH OPTIONAL FEED SENSING
(OLD STYLE)**

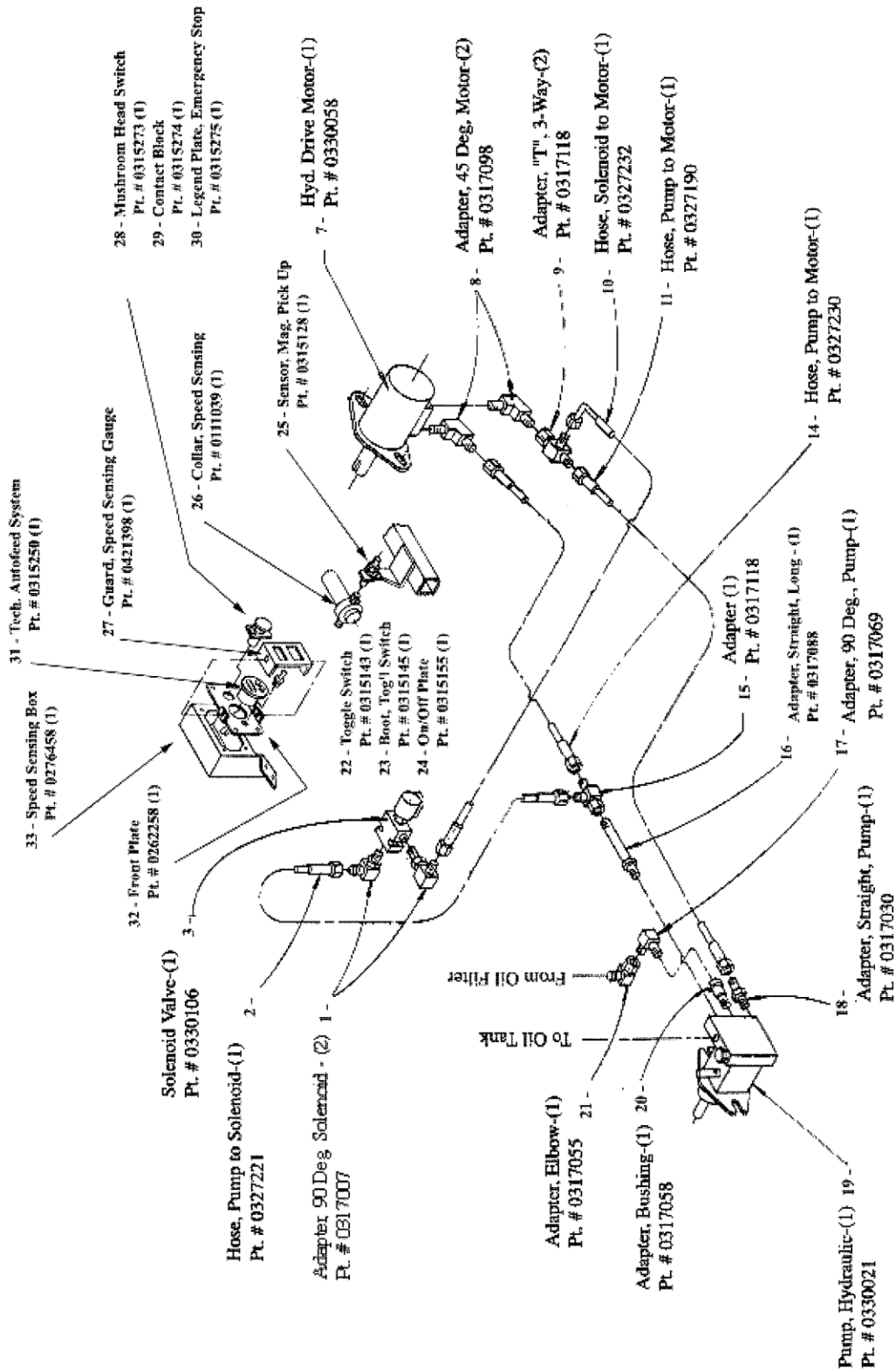

REV 01/04

HOW TO CUT A DRIVE SHAFT

- 1) Attach the implement to the tractor. Raise and lower it, **BE SURE** it's angle is correct and there is nothing hitting.
- 2) Raise and lower till the stub PTO shaft on the tractor and the implement are the closest to each other they can be.
- 3) Take a measurement **TIP TO TIP** on the stub shafts. **EXAMPLE:** Let's say 28" tip to tip is the measurement you made.
- 4) Lay the drive shaft on the bench. Close it ALL **THE WAY** and measure from inside of each yoke to the other. Don't forget the yoke must fit over the stub shaft. That's why you measure from inside the yoke. **EXAMPLE:** Let's say the drive shaft is 60" from yoke to yoke when it's in its most closed state.

28" is what we want!

60" is what we have!

Take 60"- 28" = 32" from each side

THAT'S THE AMOUNT THAT SHOULD BE CUT FROM EACH HALF OF THE DRIVE SHAFT.

- 5) **NOTES:** To remember

- A - **DON'T** forget the yoke must fit over the stub shaft.
- B - You can cut it again **EASIER** than you can add.

**SAFETY FIRST – ALWAYS WEAR PROTECTIVE GEAR
WHEN WORKING WITH/ON, EQUIPMENT/TOOLS!**

Below is a quick reference chart for various “Flat Head Cap Screws” and the torque recommendations.

VALUES ARE STATED IN FOOT POUNDS

| BOLT SIZE | Thds Per Inch | SAE Grade 5 | SAE Grade 8 |
|-----------|---------------|-------------|-------------|
| 1/4 | 20 | 10 | 14 |
| | 28 | --- | --- |
| 5/16 | 18 | 19 | 29 |
| | 24 | --- | --- |
| 3/8 | 16 | 33 | 47 |
| | 24 | --- | --- |
| 7/16 | 14 | 54 | 78 |
| | 20 | --- | --- |
| 1/2 | 13 | 78 | 119 |
| | 20 | --- | --- |
| 9/16 | 12 | 114 | 169 |
| | 18 | --- | --- |
| 5/8 | 11 | 154 | 230 |
| | 11 | --- | --- |
| 3/4 | 10 | 257 | 380 |
| | 10 | --- | --- |
| 7/8 | 9 | 382 | 600 |
| | 9 | --- | --- |
| 1 | 8 | 587 | 700 |
| | 8 | --- | --- |

Drive Belt Tension Measurement by Deflection

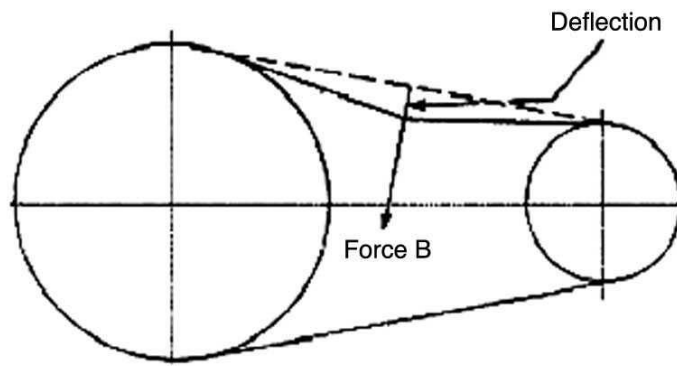

Deflection should be 3/8" when 8-12 lbs. push is applied at "B"

WARRANTY POLICY

Please remember to complete and return your Warranty Card and Dealer Delivery Report. Warranty Claims will not be considered if the Warranty Card and Dealer Delivery Report have not been returned to Salsco.

Your Salsco Commercial or Turf Equipment product is a commercial type product and is normally manufactured and sold for commercial or industrial use. **Salsco will, for the original purchaser, for one (1) year from the date of purchase (90 days if used for rental purposes) repair or replace, free of charge, any SALSCO part or parts found to be defective in material, workmanship or both.** Any transportation or shipping charges will be borne by the purchaser. If, during the warranty period stated above, the product does not function properly due to defect, simply contact Salsco and follow the Warranty Procedures included in this manual.

This warranty **does not** include:

- Incidental or consequential damages and is exclusive of any implied warranties.
- Normal maintenance parts, including, but not limited to hoses, chains, belts, filters, lubricants, etc.
- Parts or components, which are covered under the original manufacturer warranty, including, but not limited to engines, pumps, and motors.

WARRANTY PROCEDURE

In order for Salsco to consider your warranty claims in a timely manner you must follow the simple procedures listed below:

MACHINE OR PART FAILURE

- Call our service department for helpful instruction on how to correct or repair the problem. Preventive maintenance will also be suggested.
- When ordering parts for Warranty issues, you **MUST** retain possession of the old parts in question until notified with respect to returning the parts to Salsco or other disposition.
- Warranty Claims **MUST** be filed within 30-days from completion of the work performed. Contact our office for an electronic warranty claim form.
- Fill in all information requested on warranty claim form, a copy of which is included in this manual, (date of purchase, company name, address, etc.). List all parts used. Make sure part numbers are correct. You can obtain these from your manual. (include good description of problem; i.e. "leaking from spool" rather than "leaking").
- It is our goal to consider and reach a disposition on each Warranty Claim within 30-days from the date that it is received. Therefore it is important that you respond promptly to any request for further information. Claims with no response to inquiries will be closed as "**denied for lack of response**" 90-days from the date of request.
- Email, Fax or Send Warranty Claim form to our Warranty Department. – **Warranty on parts most often requires return of the parts that were replaced. DO NOT DISCARD OLD PARTS UNTIL YOU HAVE RECEIVED A DETERMINATION AS TO WHETHER THESE PARTS MUST BE RETURNED.**
- Our Warranty Department will contact and instruct you on how to return the Parts to Salsco on an RA #. Returns **MUST** be made within 30-Days from issuance of RA #. **FREIGHT CHARGES ON RETURN OF PARTS IS THE RESPONSIBILITY OF THE CUSTOMER.** Normal pre-delivery adjustments are not covered under warranty. Labor Warranties are based on reasonable time allowances as determined by Salsco, Inc. and paid at 75% of posted labor rate. **TRAVEL TIME IS NOT REIMBURSED UNDER THE WARRANTY POLICY.**
- Be sure to put the RA form inside the box that you are shipping back, also be sure to put on the outside of the box "Return of Goods" and the RA #.
- Ship returns via a traceable method such as UPS Ground Service. Be sure that the shipment is insured for the appropriate value. If uninsured parts are lost, we cannot issue a credit.

PLEASE NOTE: *Warranty forms should be filled out completely.*

PREVENTIVE MAINTENANCE IS YOUR BEST INSURANCE AGAINST EQUIPMENT FAILURE. BE SURE TO READ THIS MANUAL, ESPECIALLY THE MAINTENANCE, OPERATING AND CAUTION SECTIONS.

SALSCO, INC., 105 School House Rd.
Cheshire, CT 06410
800-872-5726, 203-271-1682
203-271-2596 (Fax)
sales@salsco.com, www.salsco.com

WARRANTY CLAIM FORM

SALSCO, INC.
105 School House Rd.
Cheshire, CT 06410

Phone:(203) 271-1682,(800) 872-5726
Fax: (203) 271-2596
Email: s.clark@salsco.com
Website: www.salsco.com

END OWNER

Date Submitted:

| | | |
|----------|--------|------------------------|
| Name: | Phone: | Work Order #: |
| Email: | Fax: | Office Use Only |
| Address: | | Date Rec'd |
| | | Cust ID: |
| | | Salsco WC |
| | | Salsco RA |

PURCHASED FROM

| | | |
|----------|--------|--|
| Name: | Phone: | Date Approved: |
| Email: | Fax: | Date Rejected: |
| Address: | | Processed By: |
| | | Dir. Del Report on File: YES NO |
| | | Warranty Card on File: YES NO |
| | | Part(s) Total: |

Equipment/Warranty Information (Must be complete)

| | | | |
|---|--------------|--------------|--------------------------------------|
| Purchase Date: | Invoice # | Date Failed: | Labor Total: |
| | | | Total Approved: |
| Model #: | Serial #: | Repair Date: | Approved/Rejected: |
| | | | Name: |
| Hrs Used: | Primary Use: | | Reason for Rejection: |
| | | | |
| Warranty Claim/Work Order#: | | | |
| Was a Salsco Return Authorization # issued for repairs or | | | |
| Return of Parts? | YES | NO | Suggested Preventative Maint: |
| Probable Cause of Failure: | | | |
| | | | |
| | | | |
| | | | |
| | | | |

| | | | |
|------------------------------------|--|--|--|
| Work Performed/Comments on Repair: | | | |
| | | | |
| | | | |
| | | | |
| | | | |

| | | | | | | | |
|------------------------------|--|--|--|------|----------------------|-------|-------|
| Shop Labor Rate: | | | | | Submitted By: | | |
| Total Labor Hours to Repair: | | | | | Printed Name: | | |
| Parts Required for repair | | | | | | | |
| Salsco Part #: Description: | | | | Qty. | Price Each | Total | Inv # |
| | | | | | | \$ | |
| | | | | | | \$ | |
| | | | | | | \$ | |
| | | | | | | \$ | |

Fill in all information requested on warranty claim form.
INCOMPLETE FORMS CANNOT BE PROCESSED & WILL BE RETURNED
List all parts used. Make sure part numbers are correct. Any parts that you believe to be defective or any parts that break should be retained for possible inspection until after the warranty has been paid or part has been replaced.

SALESMAN ID # _____

SALES MANAGER'S NAME _____

| | | |
|---|--|---|
| 800-872-5726, 203-271-1682 203-271-2596 (Fax) | SALSCO, INC. 105 School House Road Cheshire, CT 06410 | www.salsco.com sales@salsco.com |
| DEALER DELIVERY REPORT | | |
| MODEL: | SERIAL NO: | |
| DEALER: | CITY: | STATE: ZIP: |
| PURCHASER: | ADDRESS: | CITY: ST: ZIP: |
| <p>The undersigned dealer warrants that the above-described machine was carefully inspected, adjusted and prepared for delivery before delivery to the purchaser; that both the operation and maintenance of the machine were explained to the purchaser; and that a copy of the Owner's Instruction Manual were given to the purchaser and his attention called to Our Warranty and any operating instructions included in the manual and caution notes.</p> | | <p>The undersigned purchaser certifies that the operation and maintenance of the above-described machine have been explained to him; acknowledges receipt of a copy of the Owner's Instruction Manual and Our Warranty Policy printed in said Instruction Manual and Caution Notes. I also understand that it is my responsibility to explain and make Salsco manuals available to new operators.</p> |
| DATE: | DATE: | PURCHASER: |
| SIGN BY: | SIGN BY: | |
| PHONE: | FAX: | PHONE: |
| E-Mail | | EMAIL: |

| | | |
|--|--|----------------|
| MODEL: | SERIAL NO: | |
| SALSCO LIMITED WARRANTY CARD | | |
| DATE PURCHASED: | | |
| PURCHASER: | ADDRESS: | CITY: ST: ZIP: |
| EMAIL: | PHONE: | |
| DEALER: | STATE: CT | |
| Will this equipment be used commercially? | Yes | No |
| Did Dealer service this equipment and instruct you in its care and safe operation? | Yes | No |
| Did you receive an "Operation & Service Manual" and safety pamphlet? | Yes | No |
| Signed _____ | | Purchaser |
| NOTICE: | IMPORTANT: THIS CARD MUST BE FILLED OUT COMPLETELY AND MAILED TO THE FACTORY WITHIN 10 DAYS OF PURCHASE DATE, OR YOUR LIMITED WARRANTY WILL BE VOIDED. | |

