

**OPERATORS AND PARTS MANUAL
MODEL 813 WOOD/BRUSH CHIPPER**



MANUFACTURER OF OUTDOOR POWER EQUIPMENT

Products for Turf & Lawncare, Rental, Construction, Tree care, Wood Processing, Nursery & Farm Industries

Other Salsco Equipment

3-1/2" - 18", Gas, Diesel, and P.T.O, Wood/Brush Chippers

Chipper Shredder Vacuum - Tailgate & Truckloader Vacuums up to 65 HP

Shaving Mills - Gas and Electric Greens Rollers

***Quality of Workmanship, Innovative
Design, Built to Last!***

105 School House Road

Cheshire, CT 06410 U.S.A.

800-872-5726, 203-271-1682, 203-271-2596 (Fax)

sales@salsco.com, www.salsco.com

TABLE OF CONTENTS

MODEL 813 DESCRIPTION

COVER & TABLE OF CONTENTS.....Pages 1 – 2

STATEMENT OF FACT Page 3

SPECIFICATIONS & FEATURESPage 4

SAFETY INSTRUCTIONS.....Pages 5 - 7

SERVICE & MAINTENANCE INSTRUCTIONSPages 8 - 12

OPERATING INSTRUCTIONSPages 13 - 14

PARTS DIAGRAMSPages 15 – 37

HYDRAULIC SCHEMATICS.....Pages 38-50

TORQUE CHARTSPage 51

SERVICE SCHEDULE LOGPage 52

SALSCO, INC.
105 School House Road
Cheshire, CT 06410 USA
800-872-5726, 203-271-1682
203-271-2596 (Fax)
www.salsco.com, sales@salsco.com

STATEMENT OF FACT

You have just purchased the highest quality, most dependable, Wood and Brush Chipper on the market today. This unit has the ability to meet exact standards and perform for years with minimum downtime. **HOWEVER**, it cannot read nor will it understand this manual no matter how long you leave it on top of the machine.

It is your responsibility to read and understand this manual; it is also your responsibility to be certain this information is passed along to anyone who is expected to operate this equipment. Should you choose not to read, understand and pass along the information provided you, please expect equipment failure and possible injuries to persons around this equipment.

For the safety of the operator, it is **imperative** that this manual is carefully read and understood.

Once you have read this manual, it is your responsibility to be sure that all new operators read and understand this manual, especially all cautions stated.

As a manufacturer of equipment, we have a responsibility to design a safe piece of equipment. NOTE: The important safeguards and instructions in this manual are not meant to cover all possible conditions and situations that may occur. It must be understood that common sense, caution, and care are factors, which cannot be built into any product. These factors must be supplied by the person(s) caring for and operating this equipment.

ONLY YOU CAN PREVENT ACCIDENTS!

SPECIFICATIONS & FEATURES

The Salsco Model 813 & 813XT Chippers, like all of Salsco products, are ruggedly built to withstand high volume usage by the rental; commercial lawn care and tree care industries. Standard equipment includes heavy duty diamond plate fenders with safety light guards, stop, directional and safety lights, large 31.5" diameter high speed tires, lockable tool box, lockable battery box, lockable gas and hydraulic fuel tanks. Orange polyester powder coat paint offers protection against ultra violet discoloration, outdoor weatherability and resists most chemicals.

The trailer frame, constructed of 6" x 2" x 1/4" wall rectangular steel tube, continuous welded for strength and gusseted where needed provides years of towing ease. The 7,000 lb. Torflex Axle features an independent suspension, cushioned with rubber, providing a smooth, quiet ride with no transfer of road shock from one wheel to the other.

Both units have an feed opening of 13" high x 18" wide to eliminate most pruning of limbs. It will handle Christmas trees, palm fronds, viney and leafy material, with ease. There are two bed knives, one horizontal and one vertical to prevent material such as fronds and vines from wrapping around the feed roll. The 813's feed roll measures 21" in diameter by 18" long. The chipper disc is 2" thick by 40" diameter and is mounted on a 4 1/2" diameter steel hub with six exhaust blades.

Safety is always our number one concern at Salsco. Also provided on each machine, is a full set of safety decals. Simple and safe operation, easy to maintain, and built to last; **Salsco, Model 813, 13" x 18" Chippers!**

CAUTIONS

READ THOROUGHLY THE OPERATOR SAFETY INSTRUCTIONS ON THE FOLLOWING THREE PAGES, WHICH ARE THE AMERICAN NATIONAL STANDARD OF POWERED SHREDDERS/GRINDERS, SAFETY SPECIFICATIONS PROVIDED BY ANSI AND THE O.P.E.I.

THE FOLLOWING CAUTIONS ARE PROVIDED BY SALSCO AS A QUICK REFERENCE ONLY AND ARE NOT MEANT TO REPLACE THE PRECAUTIONS ON THE FOLLOWING PAGES.

1. **ALWAYS** use protective eyewear when machine is in operation.
2. **ALWAYS** use gloves and wear ear protection when machine is in operation.
3. **NEVER** put hands, legs or any part of your body into or near Chipper intake or discharge openings.
4. **NEVER** run machine with guards or shaft cover removed.
5. **ALWAYS** allow machine to cool off, remove key and put engine in neutral before attempting any maintenance or repair.
6. **BE SURE** machine has stopped completely, engine is off, key is removed and sparkplug is disconnected before attempting any service or maintenance.
7. **NEVER** stand in front of chipper infeed hopper. It is possible for a chip or piece of wood to be thrown out.
8. **BE SURE** the machine is parked on a dry level surface before starting operation.
9. **DO NOT** operate with loose clothing or long unrestrained hair. Be sure vines and branches are not wrapped around your body parts.
10. **DO NOT** operate on ice or any other slippery surface. Be sure area around machine is clear and clean. You do not want to trip into the machine.
11. **NEVER** leave machine running unattended, especially around youngsters or persons not instructed in the safe operation of this machine.
12. **NEVER** stand in front of discharge chute.
13. **NEVER** reach into infeed hopper with hand full of material. Use pusher stick provided.
14. **NEVER** push material in with your foot, use pusher stick provided.
15. **DO NOT** allow several people-feeding machines at once. As each person feeds the material in the feed hopper, he or she should turn and walk away. Leave room between your people. Only one person feeds at a time
16. **ALWAYS** when putting material in, be sure there are no rocks or debris other than wood.
17. **READ** and understand federal guidelines provided with this manual.

BRUSH CHIPPERS
ANSI Z133.1-2006
American National Standard for Arboricultural Operations
Safety Requirements

5.3 Brush Chippers

- 5.3.1 The items contained in section 5.1 shall always be included in the review of this section.
- 5.3.2 Access panels (for example, guards) for maintenance and adjustment, including discharge chute and cutter housing, shall be closed and secured prior to starting the engine of brush chippers. These access panels shall not be opened or unsecured until the engine and all moving parts have come to a complete stop (see Annex C, General Safety Procedures That Apply to All Tree Work).
- 5.3.3 Rotary drum or disc brush chippers not equipped with a mechanical infeed system shall be equipped with an infeed hopper not less than 85 inches (2.15 m) measured from the blades or knives to ground level over the center line of the hopper. Side members of the infeed hopper shall have sufficient height so as to prevent workers from contacting the blades or knives during operations.
- 5.3.4 Rotary drum or disc brush chippers not equipped with a mechanical infeed system shall have a flexible anti-kickback device installed in the infeed hopper to reduce the risk of injury from flying chips and debris.
- 5.3.5 Chippers equipped with a mechanical infeed system shall have a quick-stop and reversing device on the infeed system. The activating mechanism for the quick-stop and reversing device shall be located across the top, along each side, and close to the feed end of the infeed hopper within easy reach of the worker.
- 5.3.6 Vision, hearing, and/or other appropriate personal protective equipment shall be worn when in the immediate area of a brush chipper in accordance with section 3.4, Personal Protective Equipment.
- 5.3.7 Arborists, mechanics, and other workers shall not, under any circumstances, reach into the infeed hopper when the cutter disc, rotary drum, or feed rollers are moving.
- 5.3.8 When trailer chippers are detached from the vehicles, they shall be chocked or otherwise secured in place.
- 5.3.9 When in a towing position, chipper safety chains shall be crossed under the tongue of the chipper and properly affixed to the towing vehicle.
- 5.3.10 See section 8.6, Brush Removal and Chipping, for additional requirements.

SERVICE AND MAINTENANCE INSTRUCTIONS

A) CHECK PTO CLUTCH ADJUSTMENT. PASS THIS ALONG TO ALL SERVICE PERSONNEL! REFER TO THE CLUTCH MANUAL.

HINT: Improper adjustments of PTO clutch may shorten clutch life.
Make sure adjustments are made properly.

NOTE: New clutches or new facings usually require several, frequent adjustments until the friction facing surfaces have "worn in". The clutch friction facings will become glazed, and possibly permanently damaged if the clutch is permitted to slip.

NOTE: If your unit is equipped with a Fluid Coupler, following is a recommended list of oils to be used.

- 1) 10WT - Non-Detergent Oil
- 2) ISO32 - Hydraulic Oil
- 3) AW32 - Hydraulic Oil
- 4) VG32 - Hydraulic Oil

(Refer to the Fluid Coupler manual for further recommendations and maintenance)

E) IMPELLER REMOVAL PROCEDURE

- 1) Remove key from engine and disconnect battery cables.
- 2) Remove discharge elbow.
- 3) Remove pin lock and pivot top housing open.
- 4) Remove top-housing exhaust half.
- 5) Remove belt guard.
- 6) Remove hydraulic pump. Leave hoses connected, just slide out of sleeve and lay on the side.
- 7) Loosen engine-mounting bolts and back off slide pusher bolts. Loosen belts and remove.
- 8) Remove pulley from impeller shaft.
- 9) Remove top and bottom clevis pins from front feed wheel lift cylinder if unit is equipped with this option.
- 10) Loosen horizontal and vertical bed knives and slide them away from the impeller.
- 11) Remove chip blades from impeller. (Follow procedure in service schedule, line item #4)
- 12) Connect lifting device to impeller. (Use bolt hole for chip blade and **KEEP IN MIND - WHEN CHOOSING A LIFTING DEVICE, THE IMPELLER WEIGHS APPROXIMATELY 700 LBS.**)
- 13) Remove bolts from both flange bearings. Back off setscrews in bearings.
- 14) Carefully lift impeller out of machine.
- 15) Remove both flange bearings and all spacers from impeller.

F) INSTALLATION OF IMPELLER

- 1) Connect suitable lifting device to impeller and set in machine. **KEEP IN MIND - WHEN CHOOSING A LIFTING DEVICE, THE IMPELLER WEIGHS APPROXIMATELY 700 LBS.** Be sure both shaft ends are clean and free from burrs. Bearing must slide freely on shaft.
- 2) Slide bearings on shafts and start the four bolts, rear bearing, two front bearings diagonally.
- 3) Tighten four bolts on rear bearing and two bolts on front bearing, diagonally.
- 4) Slide impeller towards rear of machine. Impeller hub should touch rear-bearing race.
- 5) Measure distance from impeller hub and front bearing race.
- 6) Remove front bearing slide shims over shaft to equal that distance **CAUTION: DO NOT ADD MORE SHIMS THAN ARE REQUIRED.** This could cause premature bearing failure. Reinstall front bearing.
- 7) With impeller shimmed and bearings tight, impeller should not slide front or rear.
- 8) Install all bearing mounting bolts with blue Loctite. Also, Loctite and tighten bearing set screws.
- 9) Install all chip blades. Be sure to use new hardware and Loctite each time blades are removed and reinstalled. (Follow procedure in service schedule, line item #4.)
- 10) Set bed knives and lock in place. **(.070 clearance between chip blades and bed knives).**

http.....

my.sharepoint.com/personal/garrettkaelin_foleyco_com/Documents/Desktop/Manuals/Working Files/813
Chipper Manual 3.27.26.docx

INSTALLATION OF IMPELLER (Continued from previous page)

- 11) Reinstall top housing and discharge elbow. Be sure to use roll pin to keep housing aligned.
- 12) Install pulley. Be sure to use straight edge to line up pulley.
- 13) Install belts and adjust to specs shown in service manual with discharge chute and impeller assembly.
- 14) Be sure to recheck pulley with straight edge.
- 15) Install pump and use Loctite.
- 16) Install belt guard.
- 17) Install front lift cylinder, if so equipped.
- 18) Check to be sure all guards are in place and all bolts and nuts have been installed and tightened to proper specs.
- 19) Connect battery cables and start engine.
- 20) Engage clutch slowly. Start impeller and check for noise or vibration.
- 21) Engage impeller and bring engine up to operating R.P.M. **DO NOT START UNIT WITHOUT ALL GUARDS IN PLACE.**
- 22) Test lift cylinder feed wheel, if so equipped.
- 23) Lower feed wheel and bring engine to idle.
- 24) Shut down engine and put machine in neutral.
- 25) Once machine has come to a halt, re-grease bearings.
- 26) Send machine to work. It is ready!

**REMEMBER! REMOVE KEY FROM ENGINE, DISCONNECT BATTERY CABLES
AND LOCKOUT UNIT WHENEVER PERFORMING SERVICE AND MAINTENANCE**

G) TESTING HYDRAULIC FEED ROLL PRESSURE (See drawing on following page)

The following are instructions for checking and setting the pressure on the hydraulic feed roll. This should only be necessary if any hydraulic components are changed or if the feed roll looks sluggish or seems to stop momentarily during normal feed function. This check should be made yearly to assure the maximum performance from your Salsco chipper.

Please call with any questions on this or any other problems.

- 1) **With the motor off**, loosen the acorn nut at the pressure relief. Remove the cap and washer. Set aside until later. Loosen the jamb nut and back the screw out counter clockwise 3 - 4 turns, at least.
- 2) If you have caps for the hoses, remove them at the drive motor and cap. **NOTE:** Be sure to mark the hoses for reassemble.

If you **do not have** the proper caps for the hydraulic lines, you can deadhead the system by wedging a piece of wood in the feed chute as shown. This will create system pressure.
- 3) Be sure the feed handle is in neutral and starts engine. Engage chipper section at low R.P.M. (1200 - 1300 R.P.M.)
- 4) Walk to rear of machine and move the feed handle to the feed position. Gauge should move and show a pressure increase.
- 5) If there is no pressure on gauge, turn relief screw in 1 - 2 turns. If no pressure on gauge, back screw off to start position. Stop machine. Shut down engine and put gauge in other line of valve.
- 6) Repeat start up procedure. Now pressure should show in gauge. Once pressure shows in gauge, raise engine R.P.M. to 2500 R.P.M. Turn screw clockwise until 1500 P.S.I. is reached on gauge. Put the control valve in neutral and tighten jamb nut. After jamb nut and acorn nut and washer have been replaced and tightened, check pressure again. Do not run over 1500 P.S.I.
- 7) Remove gauges, caps, wood, etc. and reassemble the machine the way it was when you started. Run and check all hoses for possible leaks.
- 8) Check hydraulic tank. Replenish if necessary.

SET-UP FOR SETTING HYDRAULIC PRESSURE

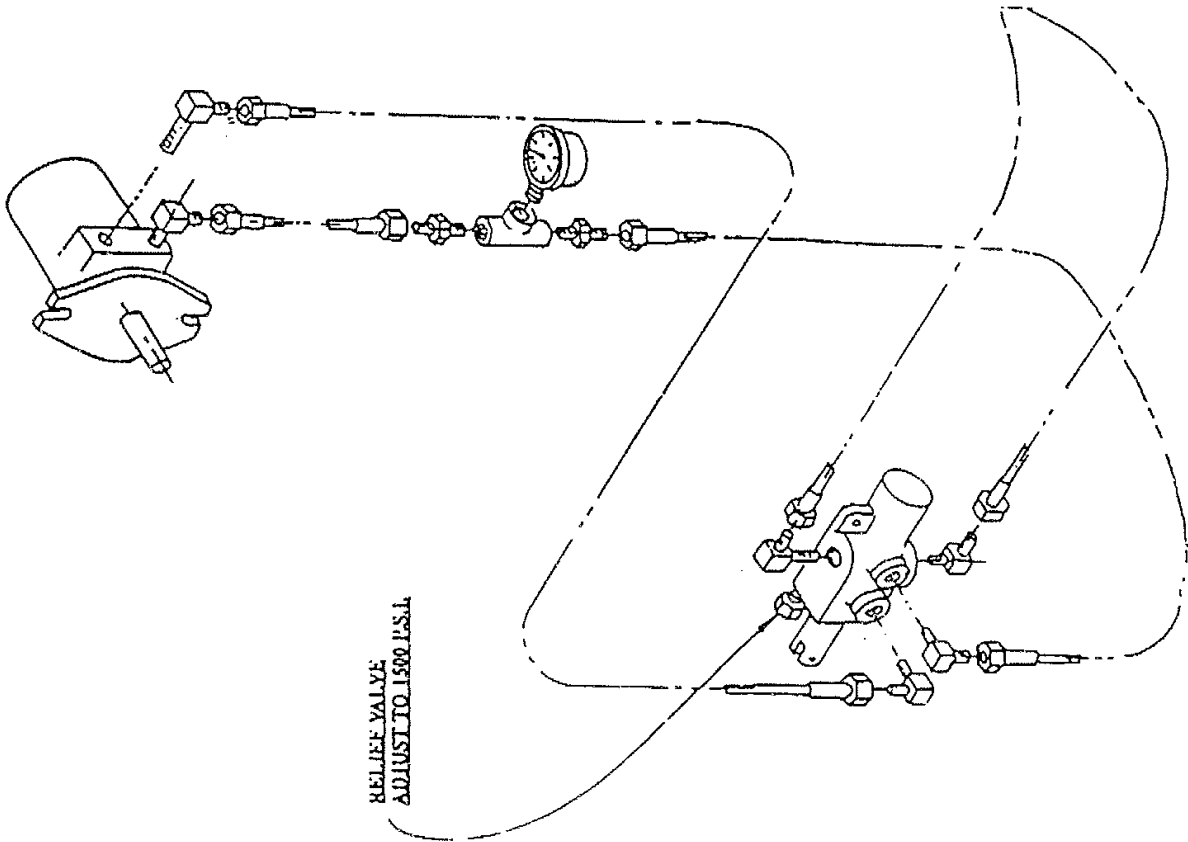
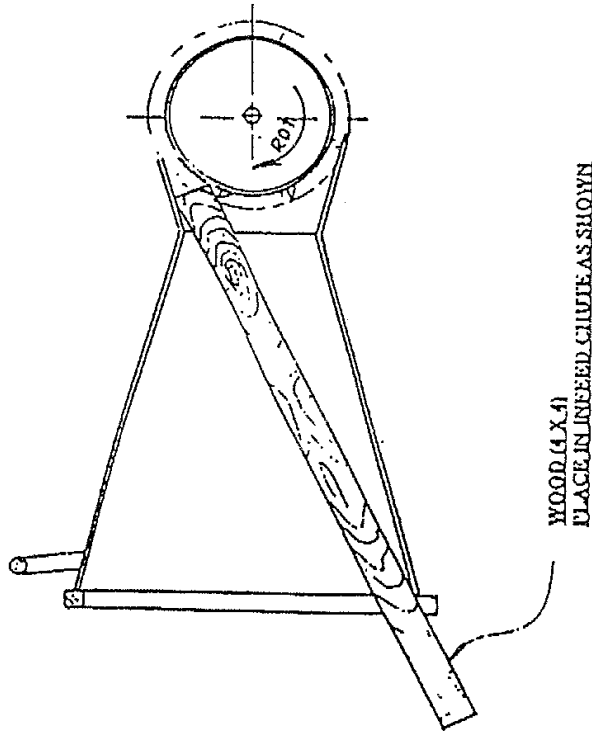

H) SERVICE SCHEDULE

1. **Engine & Clutch adjustments** - follow service maintenance schedule set forth by the manufacturer in the engine and clutch manual.
2. **Grease** all main bearings once a day. **DO NOT OVER GREASE.** Wipe extra grease off bearings. Bearing under guards for feed rolls, need to be greased at least once a week. When removing guards, check chain tension.
3. Be sure to **clean** entire machine, especially around engine after using. Should it become necessary to remove the exhaust chute, **REMOVE KEY FROM ENGINE. NEVER TURN ENGINE OVER WHILE EXHAUST CHUTE IS REMOVED.**
4. **Sharpen/change chipper blades:** Remove the engine key and remove spark plug wire (gas engines only). Be sure throttle is in off position and clutch is disengaged. Be sure to put a red lock out tag on this machine to warn others of pending danger. Be sure everything has stopped moving before removing any guards or before you start to work on this machine. Remove top pin from chipper housing access door and pivot housing open. This will allow access to impeller. Rotate impeller to a comfortable working position and tighten pusher screw against the impeller. This will lock the impeller while you service the blades. Sharpen blades as evenly as possible, be sure to use Loctite, and tighten all bolts. A loose bolt coming out of this machine would be a large bullet. Should you drop a nut, bolt, or blades in the housing you must retrieve it before you start up the machine. **HINT:** Salsco recommended replacement of nuts, bolts, and washers, when replacing or sharpening chipper blades. The locking ability of these parts may have been violated. **HINT:** It is strongly recommended to have a set of blades, bolts, nuts and washers, on the shelf, to prevent downtime while blades are being sharpened. **HINT:** Blades need sharpening after approximately 8 - 15 hours of use.
5. **Bed knife adjustment** on hydraulic feed machines is .070. To adjust the vertical bed knife, remove access door on side of chip chamber and rotate impeller until blades pass in front of bed knife. Check with feeler gauge and set to .070. Repeat procedure for horizontal knife.
6. **Adjust infeed roll housing:** Remove both guards, pry housing front or rear, and shim behind nylon. Tighten up and remove play. Check chain adjustment on infeed roll assembly. Remove guards and adjust chain.
7. **Check belt for wear and or adjustment:** Belt needs adjustment when belt is loose. Adjust belt as follows: Loosen four bolts holding engine and adjust engine to tighten belts. You must remove the belt guard for proper access to belts.
8. **Remove infeed hopper: Infeed hopper is removable for maintenance or storage, but unit must NEVER run without the hopper in place.** Connect chain hoist or lifting device of some sort and remove bolts. Now hopper can be stored.
9. **Remove feed roll box:** Periodically the feed roll assembly will require disassembly. Remove the tow hoses going to the drive motor. (Be sure to mark them for reassemble) Also, you must check the rotation of the feed roll upon reinstallation. Cap open hydraulic hoses. **Dirt is any hydraulic system enemy.** Connect chain hoist or lifting device to feed roll box assembly and remove from machine. The feed roll can now be worked on to make necessary repairs. When replacing the feed roll box, be sure to shim behind the nylon wear strips to remove endplay.
10. **Oil & Filter Type** - It has been determined that your Salsco machine will perform better by using a 25 micron filter. Salsco recommends using Mobil DTE 26 or Citgo HYD 68, non-detergent hydraulic oil, or their equivalents. The oil should have a viscosity rating of at least 100 SSU. While this is not a necessity, it will improve the overall performance of your machine. Salsco is now using this filter and hydraulic oil on all our machines using hydraulics.

The following schedule is provided as a guide to regular service. We suggest that you fill in the service schedule provided with this manual. This unit will provide many years of dependable service if maintenance guides and schedules are followed. Should you have any questions about the service and maintenance on this unit, please either contact your Salsco Dealer or Salsco direct.

SERVICE SCHEDULE	AS NEEDED	DAILY	WEEKLY	MONTHLY
CHECK WHEEL BEARINGS	X			X
CHECK LUG NUTS	X			X
CHECK LIGHTS	X	X		
CHECK ENGINE OIL	X	X		
CLEAN MACHINE	X	X		
GREASE INFEED ROLL BEARING	X		X	
GREASE DISC SHAFT BEARING	X	X		
SHARPEN CHIPPER BLADES	X OR		X	
CHECK & ADJUST BED KNIFE	X OR		X	
CHECK & ADJUST ROLL HOUSING				X
CHECK TIRE AIR PRESSURE	X			X
CHECK ALL NUTS & BOLTS	X	X		
CHECK ENGINE BELT TENSION	X		X	
CHECK HYDRAULIC OIL	X			X
CHECK HYDRAULIC HOSES	X			X

WHENEVER PERFORMING SERVICE ON ANY PIECE OF OUTDOOR POWER EQUIPMENT, A RED LOCKOUT TAG SHOULD BE PLACED ON THE UNIT.

OPERATING INSTRUCTIONS
Count your extremities before you start!
Feet, hands, fingers, etc

NEVER - Run this machine without a dedicated operator to control the Forward/Reverse handle.

ALWAYS watch chipper shaft when starting machine or engaging the clutch. If the shaft does not begin to turn easily, stop the engine, and check for a piece of wood, that may be keeping the disc from turning. **Avoiding this procedure will cause clutch or fluid coupler failure.**

- 1) Read the manual again.
- 2) Look at the finger decal and study it. These could be yours!
- 3) Be sure all guards are in place before starting machine.
- 4) Set feed handle in reverse position (push towards machine).
- 5) Check engine oil and fuel levels, as per engine manufacturer specifications.
- 6) Be sure machine is on a dry, flat surface and it is secured from rolling.

HINT: BE SURE MACHINE IS NOT TOO CLOSE TO THE WOOD PILE. YOU NEED ROOM TO WORK AND MOVE AROUND.

- 7) Set engine just above idle and start motor. (Be sure to check that no one is around this machine. Only trained personnel should be allowed to operate or be around this machine.)
- 8) With machine just over idle and after the engine has warmed up, engage the clutch slowly.
- 9) Check engine manual for full throttle R.P.M. and recommendations and bring your machine to that R.P.M.
- 10) You are ready to chip wood as soon as you put your safety glasses and gloves on and insert your earplugs.
- 11) Move the feed handle away from the machine. This will engage the feed roll.
- 12) Standing at the rear of the machine, looking at the hopper, feed the wood to the feed roll. Once the machine begins, turn and walk away from the machine. It will draw the wood in without your help. Go get another piece and repeat the procedure.
- 13) **HINT:** The impeller weighs approximately 750 lbs. **Raise and lower R.P.M. slowly.** This procedure will add life to your clutch or fluid coupler, as well as the engine.
- 14) With large diameter pieces, it may be necessary to send in a smaller piece to start feed roll. Also, it may be necessary to monitor R.P.M. and back off on feed speed.
- 15) **MACHINE SHUTDOWN PROCEDURES:** Bring R.P.M. down to a full idle and disengage the clutch. Let the engine run a few minutes to cool down and then shut down. Chipper flywheel will still be rotating.

NEVER PERFORM ANY SERVICE OR MAINTENANCE, OR REMOVE ANY GUARDS WHILE THE FLYWHEEL IS MOVING!

OPERATING PROCEDURE HINTS

- 1) When operating machine, stand off to the side of the feed hopper when feeding wood into the machine. **NEVER STAND DIRECTLY IN FRONT OF THE FEED HOPPER WHEN FEEDING WOOD INTO THE MACHINE.**
- 2) When using the chipper and you have a short piece of wood bouncing around and not being grabbed by the feed roll, **LEAVE IT! DO NOT TRY TO PUSH IT THROUGH WITH ARMS OR LEGS!** The next limb will push it through.
- 3) When through with the job, let the engine run at full R.P.M., making sure **all material is run through the machine before shutting it down.** This will prevent any injuries from flying debris when the machine is started up at the next job.
- 4) **COUNT YOUR EXTREMITIES AGAIN. BE SURE THIS NUMBER MATCHES YOUR STARTING NUMBER.**
- 5) There is nothing funny about this machine. It has no mercy and will not slow down.

- **STAY ALERT!**
- **PAY ATTENTION!**
- **KNOW YOUR FELLOW CO-WORKERS WHEREABOUTS AT ALL TIMES!**
- **NEVER LET ANYONE OPERATE THIS MACHINE WITHOUT THE PROPER TRAINING!**
- **REMEMBER, THIS MACHINE CAN CHIP UP A TELEPHONE POLE IN 1-MINUTE!**

ISSUED: 07-12-2010

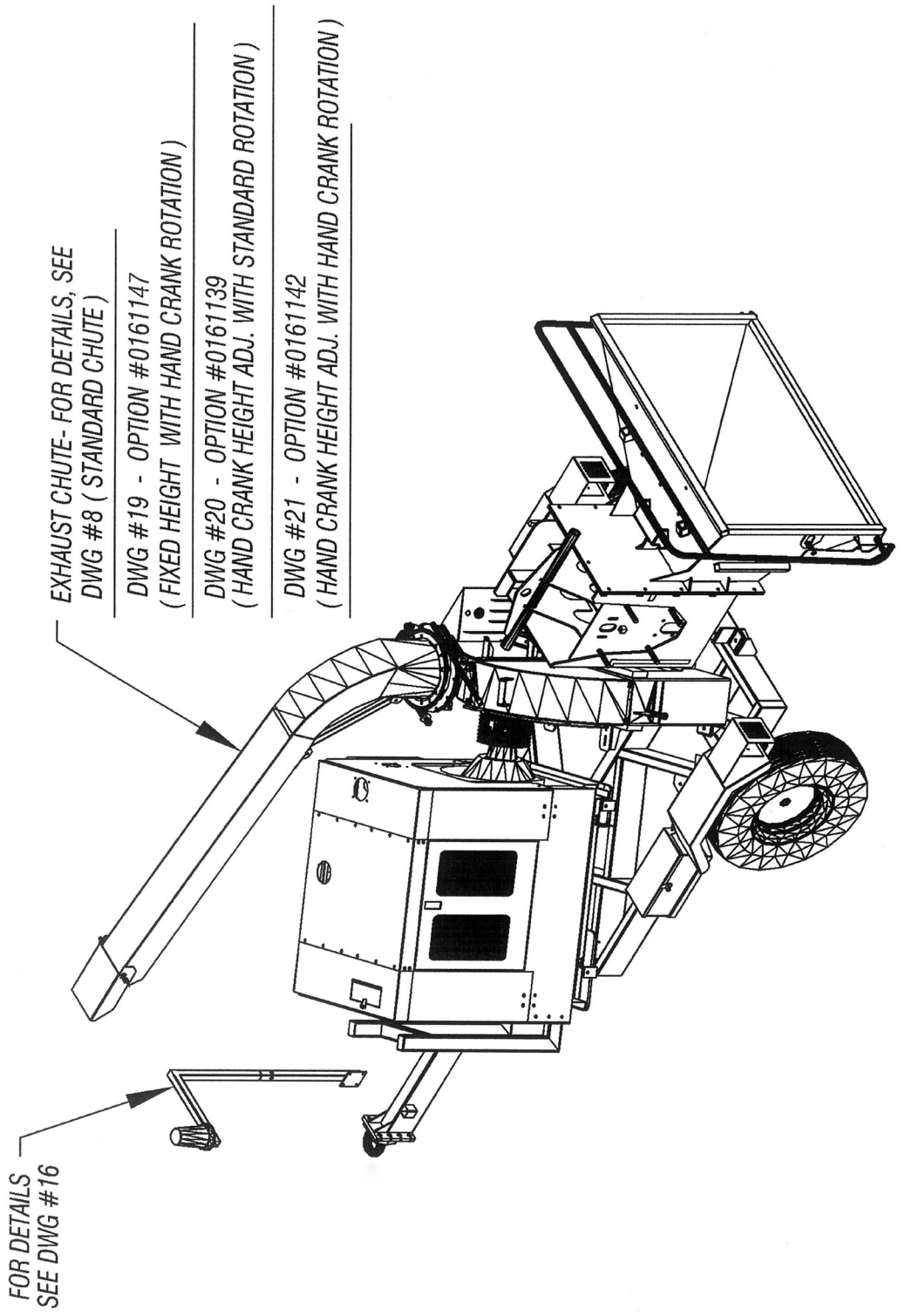

813 CHIPPER ASSY - DWG #1

ISSUED: 07-12-2010

ITEM	DESCRIPTION	PART NO	QTY
1	ENGINE- CATERPILLAR, 91HP C4.4 TIER 3	0337498	1
-	SUB ASSY.PACKAGE- CAT. - 91HP TIER 3	0137521	1
2	ENG. CLUTCH (STD)	0337076	1
3	ENG. ENCLOSURE	0137380	1
4	ENG. MOUNTING FRAME	0219340	1
5	ENGINE- CATERPILLAR, 127HP C4.4 TIER 3	0337518	1
-	SUB ASSY.PACKAGE- CAT. - 127HP	0137525	1
6	ENG. CLUTCH (STD)	0337076	1
7	ENG. ENCLOSURE	0137380	1
8	ENG. MOUNTING FRAME	0219330	1
9	ENGINE- JOHN DEERE, 80HP 4045TF280 TIER 3	0337516	1
-	SUB ASSY.PACKAGE- J.D.- 80 HP	0137389	1
10	ENG. CLUTCH (STD)	0337076	1
11	ENG. ENCLOSURE	0137526	1
12	ENG. MOUNTING FRAME	0219101	1
13	ENGINE- JOHN DEERE, 115HP 4045HF285 TIER 3	0337515	1
-	SUB ASSY.PACKAGE- J.D. - 115 HP	0137513	1
14	ENG. CLUTCH (STD)	0137076	1
15	ENG. ENCLOSURE	0337514	1
16	ENG. MOUNTING FRAME	0219101	1

NOTE: ALL ENGINES ARE AVAILABLE WITH OPTIONAL
FLUID COUPLER CLUTCH #0337390

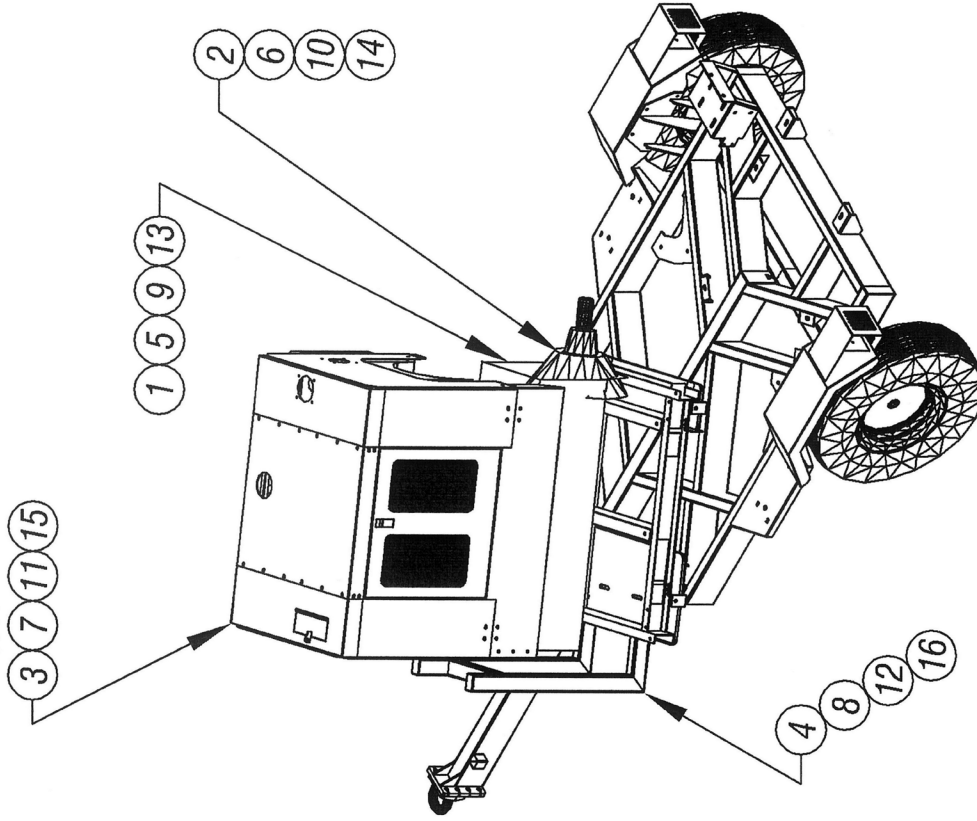

ENGINE OPTIONS
813 CHIPPER - DWG #2

ISSUED: 07-12-2010
 ISSUED: 12-09-2011

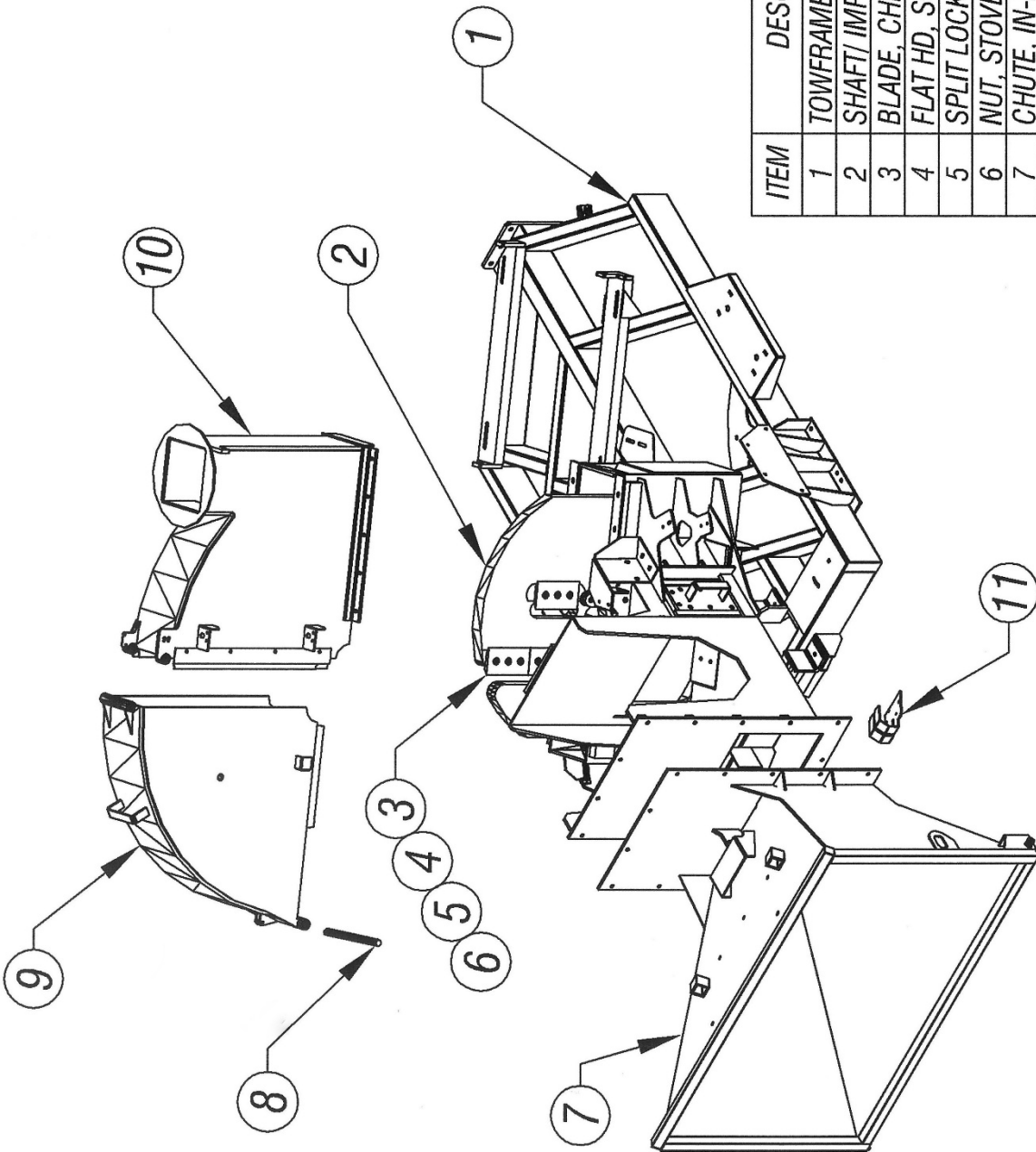

ITEM	DESCRIPTION	PART NO	QTY
1	TOWFRAME, BASE	0219435	1
2	SHAFT/ IMPELLER	0148078	1
3	BLADE, CHIP	0305047	6
4	FLAT HD, SOCKET CAP SCREW	0346491	18
5	SPLIT LOCK WASHER	0353017	18
6	NUT, STOVER	0338154	18
7	CHUTE, IN-FEED	0226048	1
8	PIN, HINGE- HSG UPPER	0440034	1
9	HOUSING, UPPER - REMOVABLE	0228114	1
10	HOUSING, UPPER - FIXED	0228113	1
11	BRACKET, GUARD H. LIFT VALVE	0406476	1

813 CHIPPER - DWG #3

ISSUED 07-12-2010

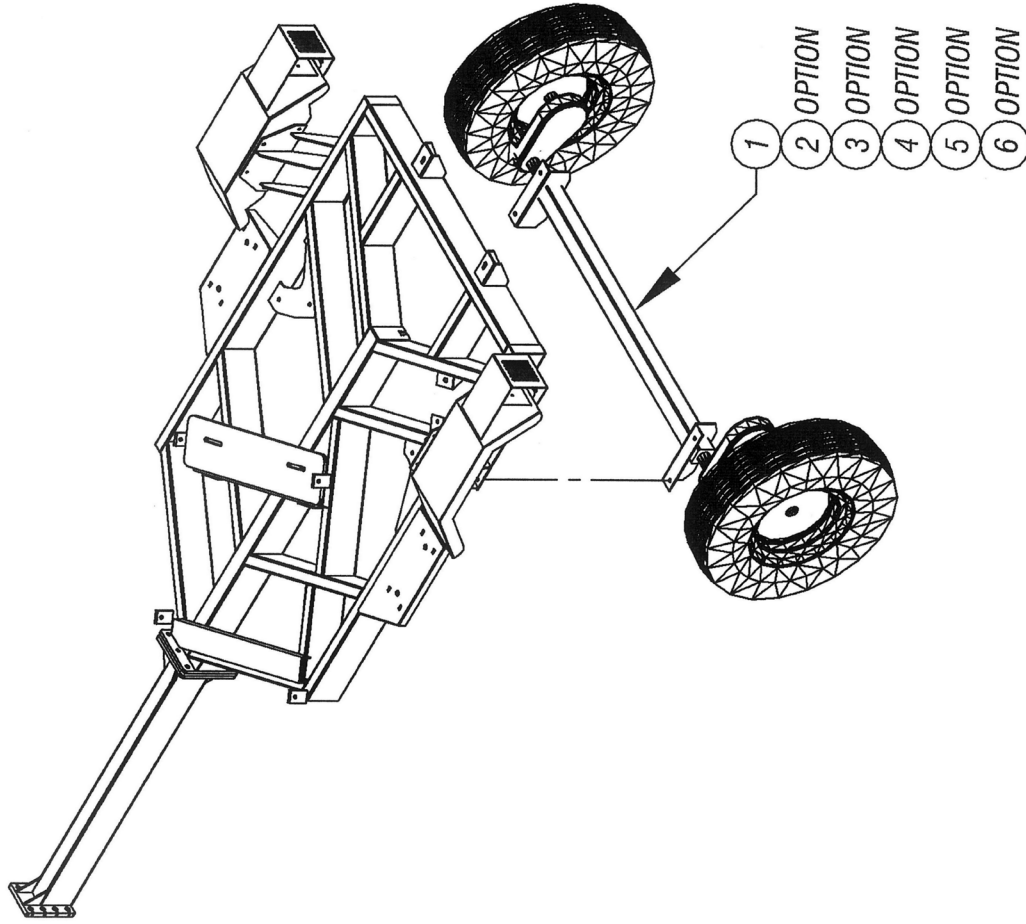

ITEM	ASSY DESCRIPTION	PART NO.	QTY
1	AXLE, 7000# IDLER	0161191	1
INCLD	#12 TORFLEX AXLE	0302041	1
INCLD	TIRE / WHEEL ASSY (STD)	0354035	2
2	AXLE, 7000# ELECTRIC	0161190	1
INCLD	#12 TORFLEX AXLE	0302040	1
INCLD	TIRE / WHEEL ASSY (STD)	0354035	2
3	AXLE, 7000# SURGE	0161195	1
INCLD	#12 TORFLEX AXLE	0302043	1
INCLD	ACTUATOR	0302095	1
INCLD	6-HOLE CHANEL BRKT/COUPL.	0306359	1
INCLD	TIRE / WHEEL ASSY (STD)	0354035	2
4	AXLE, 7000# IDLER	0161193	1
INCLD	#12 TORFLEX AXLE	0302084	1
INCLD	TIRE / WHEEL ASSY (WD)	0354045	2
5	AXLE, 7000# ELECTRIC	0161192	1
INCLD	#12 TORFLEX AXLE	0302053	1
INCLD	TIRE / WHEEL ASSY (WD)	0354045	2
6	AXLE, 7000# SURGE	0161194	1
INCLD	#12 TORFLEX AXLE	0302058	1
INCLD	ACTUATOR	0302095	1
INCLD	6-HOLE CHANEL BRKT/COUPL.	0306359	1
INCLD	TIRE / WHEEL ASSY (WD)	0354045	2

813 CHIPPER - DWG #4

ISSUED: 07-12-2010

ITEM	DESCRIPTION	PART NO	QTY
1	HOUSING, IMPELLER- LOWER	0228267	1
2	YOKE, FEED WHEEL	0274011	1
3	ADJUSTER, ACTUATOR	0201044	1
4	LEVER, ACTUATOR - EXTENDED	0233136	1
5	GUARD, FWD / REVERSE ROD	0221408	1
6	CHUTE, IN-FEED	0226052	1
7	HANDLE, FORD/REVERSE POW.FEED	0223037	1

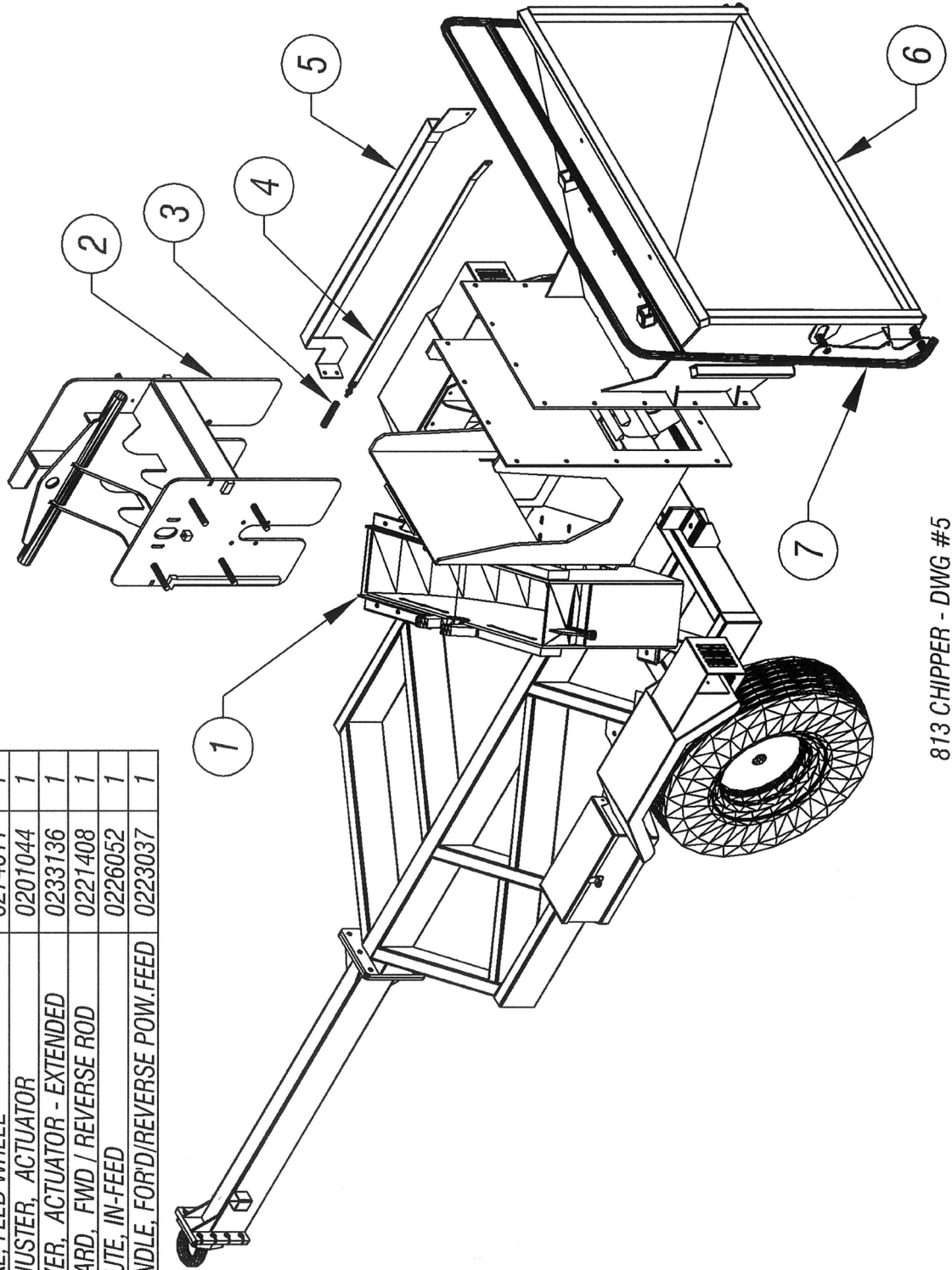

813 CHIPPER - DWG #5

ISSUED: 07-12-2010

ITEM	DESCRIPTION	PART NO	QTY
1	GUARD, IDLER FD WHEEL CHAIN	0221133	1
2	GUARD, DR. FEED WHEEL CHAIN	0221132	1
3	GUARD, UPPER BELT	0221126	1
4	COVER, ENGINE SHAFT	0271314	1
5	SUPPORT, GUARD, UPPER BELT	0277027	1
6	CAP, IMPELLER SHAFT	0271086	1
7	GUARD, LOWER BELT	0221127	1
8	GUARD, ENGINE SHEAVE	0421442	1
9	GUARD, ENGINE SHEAVE	0421472	1

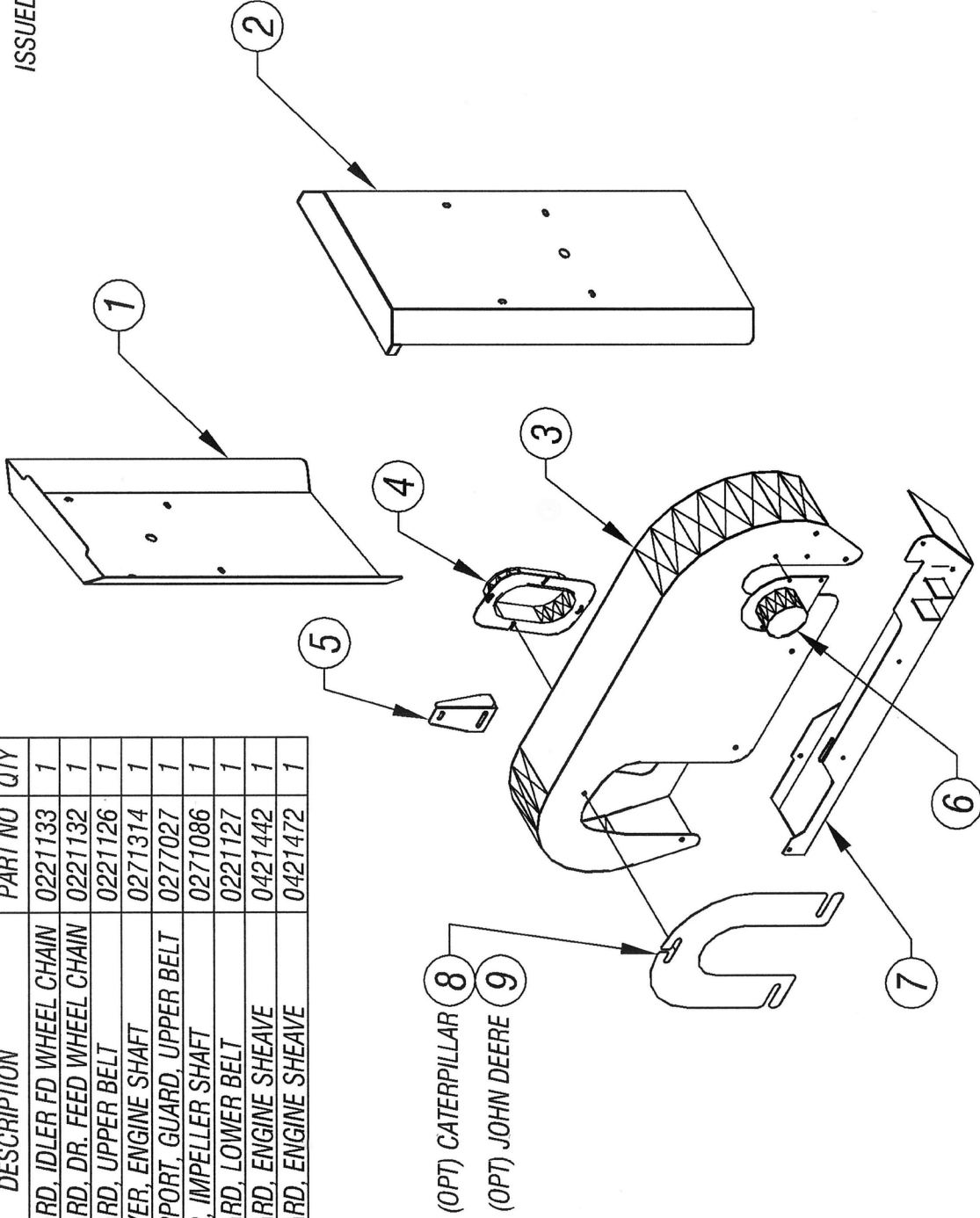

(OPT) CATERPILLAR
(OPT) JOHN DEERE

NOTE:
(OPT) = GUARD FOR ENGINE OPTION

813 CHIPPER - DWG #6

ISSUED: 07-12-2010

ITEM	DESCRIPTION	PART NO	QTY
1	YOKE, FEED WHEEL	0274011	1
2	WHEEL, POWER FEED	0254032	1
3	WEAR BAR KIT	0161122	4
4	SPACER/SHIM KIT	0161120	2
5	BEARING, 4 BOLT FLANGED	0303002	2
6	SPROCKET ASSY - #80 CHAIN	0251051	1
7	#80 ROLLER CHAIN 45 PITCHES	0309071	1
8	#80 MASTER LINK	0309038	1
9	#80 HALF LINK	0309039	1
10	SHAFT & SPROCKET WELDMENT	0248093	1
11	HYD. DRIVE MOTOR- UPPER	0330144	1
12	MOUNT, HYD. MOTOR- UPPER	0476059	1
13	SPROCKET ASSY - #50 CHAIN	0351023	1
14	#50 ROLLER CHAIN 68 PITCHES	0309031	1
15	#50 MASTER LINK	0309033	1
16	#50 HALF LINK	0309034	1
17	SPROCKET ASSY - #50 CHAIN	0251040	1
18	SPACER, SPROCKET	0449074	1
19	BEARING, 2 BOLT FLANGED	0303031	2
20	GREASE FITTING	0317001	7

NOTE:

⊗ ALL GREASE POINTS ON THE CHIPPER ARE IDENTIFIED ← GREASE

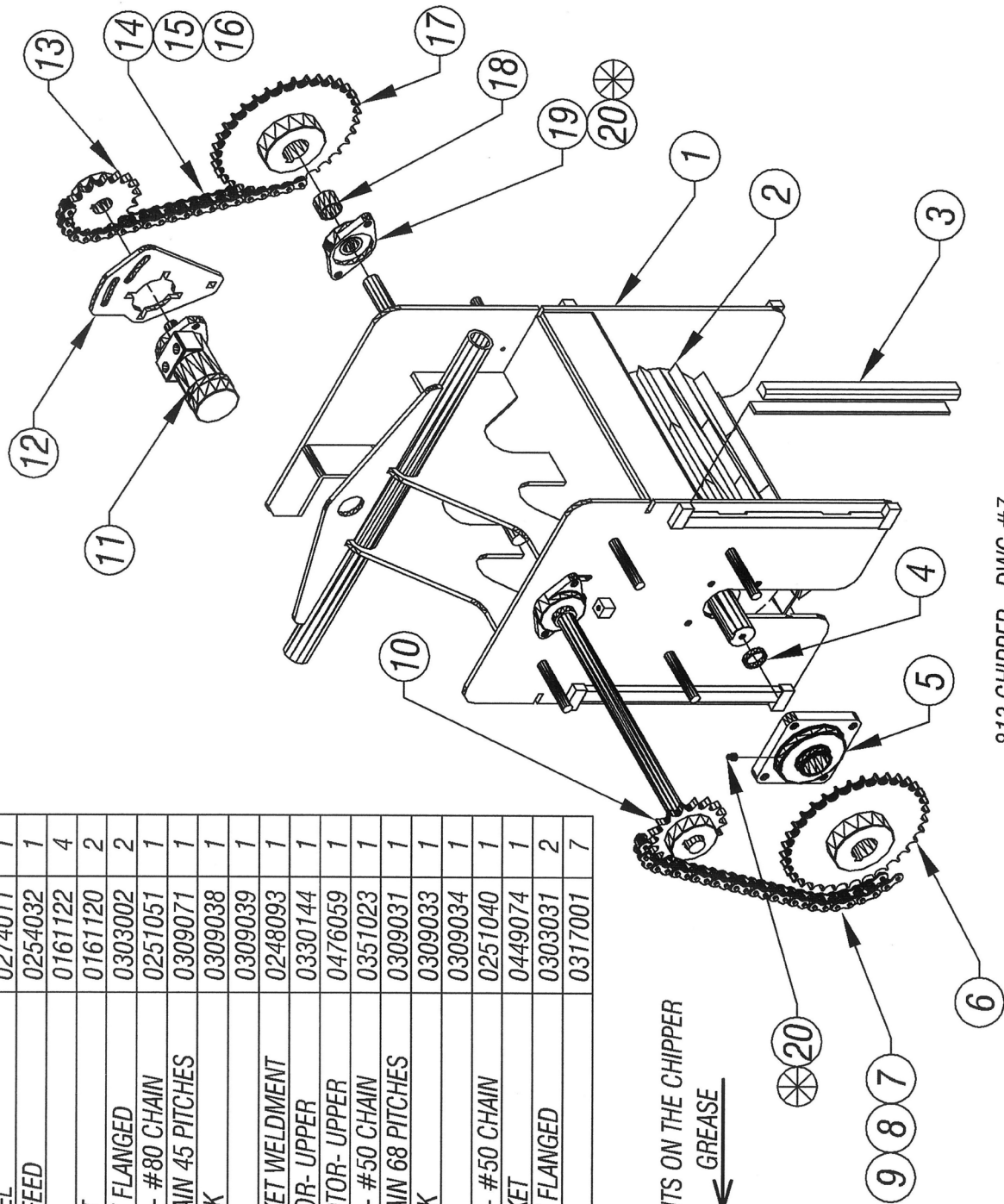

813 CHIPPER - DWG #7

ISSUED: 07-12-2010

ITEM	DESCRIPTION	PART NO	QTY
1	CHUTE, DISCHARGE	0226052	1
2	WING NUT	0238500	1
3	LOCK WASHER, SPLIT	0353005	1
4	BOLT, CARRAGE	0346429	4
5	FLAT WASHER	0353104	4
6	NUT, NYLON LOCK	0338104	3
7	CHUTE, DEFLECTOR	0426028	1
8	CLAMP, REAR HALF	0210070	1
9	WING NUT, 3/4-10	0238501	2
10	CLAMP, FRONT HALF	0210067	1
11	CLAMP STRIP, - 1/8 x 3/8 x 14"	0356045	1

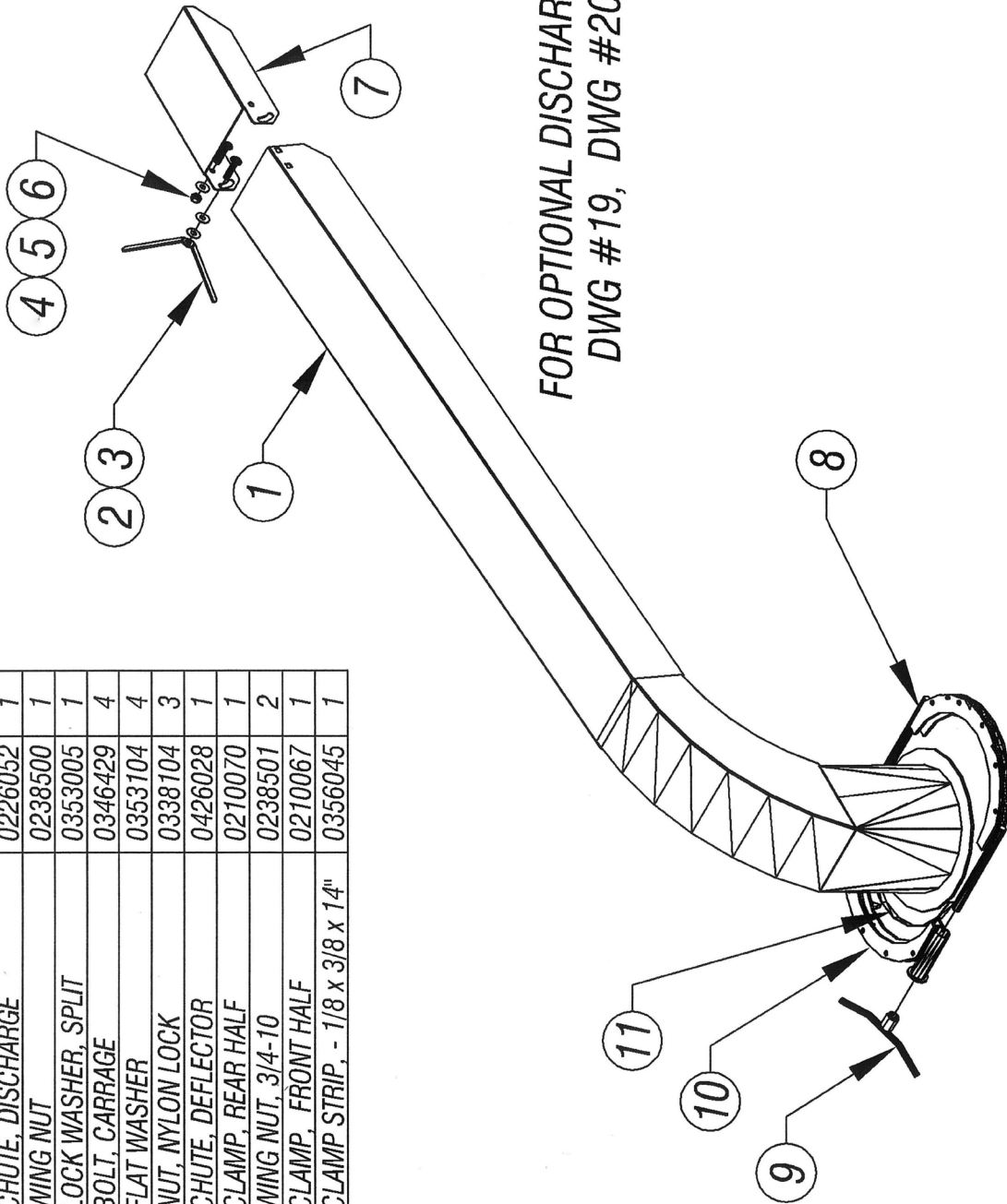

FOR OPTIONAL DISCHARGE CHUTE, SEE
DWG #19, DWG #20, DWG #21

STANDARD CHUTE
813 CHIPPER - DWG #8

ISSUED: 07-12-2010

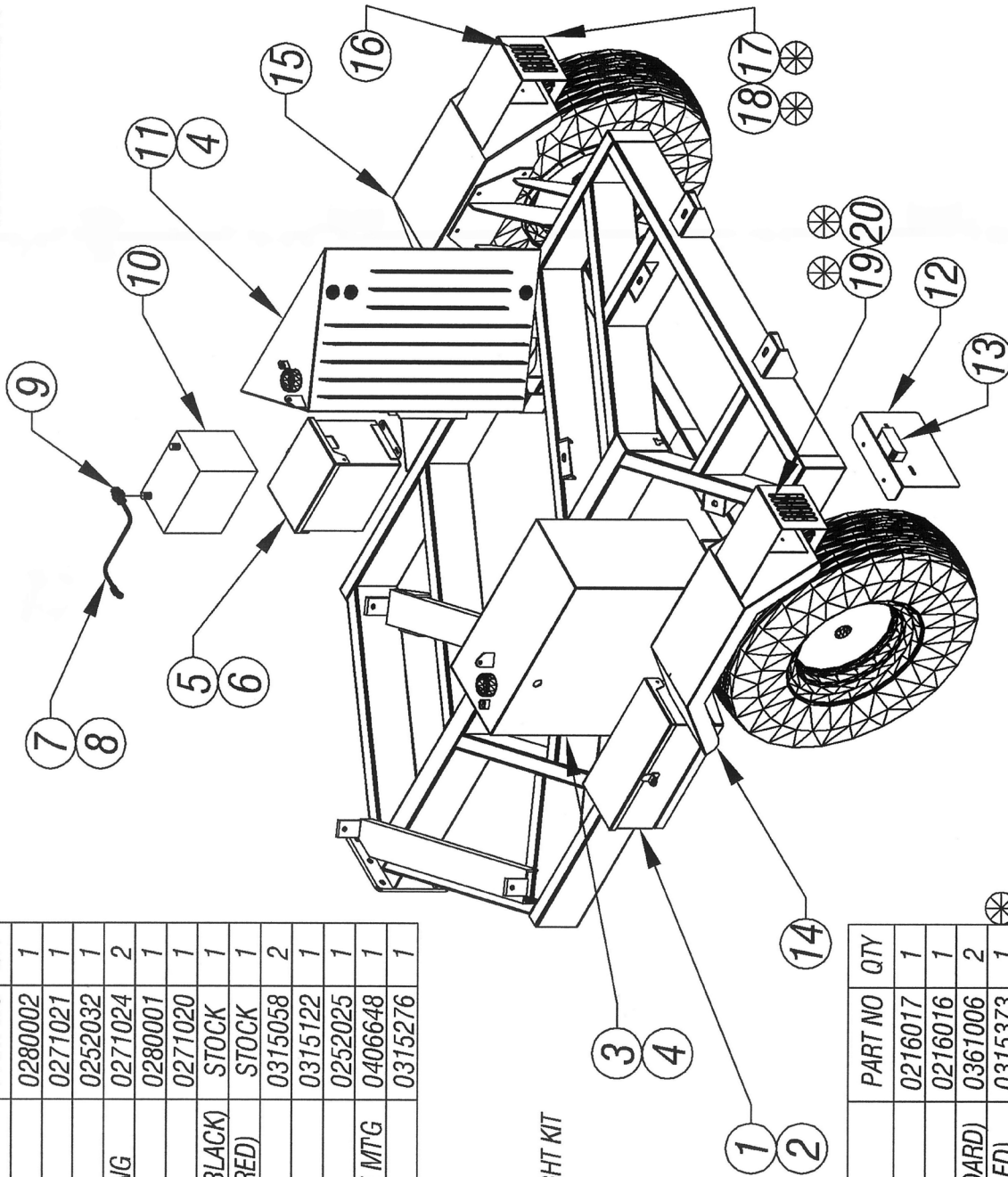

813 CHIPPER - DWG #9

ITEM	DESCRIPTION	PART NO	QTY
1	TOOL BOX	0280002	1
2	COVER, TOOL BOX	0271021	1
3	TANK, FUEL	0252032	1
4	CAP, GAS/OIL FILL LOCKING	0271024	2
5	BATTERY BOX	0280001	1
6	COVER, BATTERY BOX	0271020	1
7	BATTERY CABLE, 2 GA.- (BLACK)	STOCK	1
8	BATTERY CABLE, 2 GA.- (RED)	STOCK	1
9	TOP POST TERMINAL	0315058	2
10	BATTERY, 12 VOLT	0315122	1
11	TANK, HYDRAULIC OIL	0252025	1
12	BRACKET, LICENSE PLATE MTG	0406648	1
13	LICENSE PLATE LIGHT	0315276	1

NOTE:

⊗ OPTIONAL LED TRAILER LIGHT KIT

ITEM	DESCRIPTION	PART NO	QTY
14	FENDER - LEFT	0216017	1
15	FENDER - RIGHT	0216016	1
16	TRAILER LIGHT KIT (STANDARD)	0361006	2
17	TAILLIGHT - RIGHT (NON-LED)	0315373	1
18	TAILLIGHT - RIGHT (LED)	0315338	1
19	TAILLIGHT - LEFT (NON-LED)	0315373	1
20	TAILLIGHT - LEFT (LED) & L.P.L.	0315339	1

ISSUED: 07-12-2010

ITEM	DESCRIPTION	PART NO	QTY	ITEM	DESCRIPTION	PART NO	QTY
1	ENGINE	OPT	1	8	SHEAVE, IMPELLER	0342073	1
2	CLUTCH	OPT	1	9	BUSHING, IMPELLER SHEAVE	0342074	1
3	6.7" SHEAVE, FOR 2500 RPM ENG.	0342126	1	10	BEARING, 4-BOLT FLANGED	0303035	2
4	8" SHEAVE, FOR 2250 RPM ENG.	0342190	1	11	HOUSING, IMPELLER - LOWER	0228267	1
5	BUSHING, FOR 6.7" ENG. SHEAVE	0342127	1	12	STOP IMPELLER- 3/4-10 x 9" LG	STOCK	1
6	BUSHING, FOR 8" ENG. SHEAVE	0342075	1	13	HEX NUT- 3/4-10	0338033	2
7	BELT, MOTOR TO IMPELLER	0304120	5	14	SHAFT/ IMPELLER	0148078	1

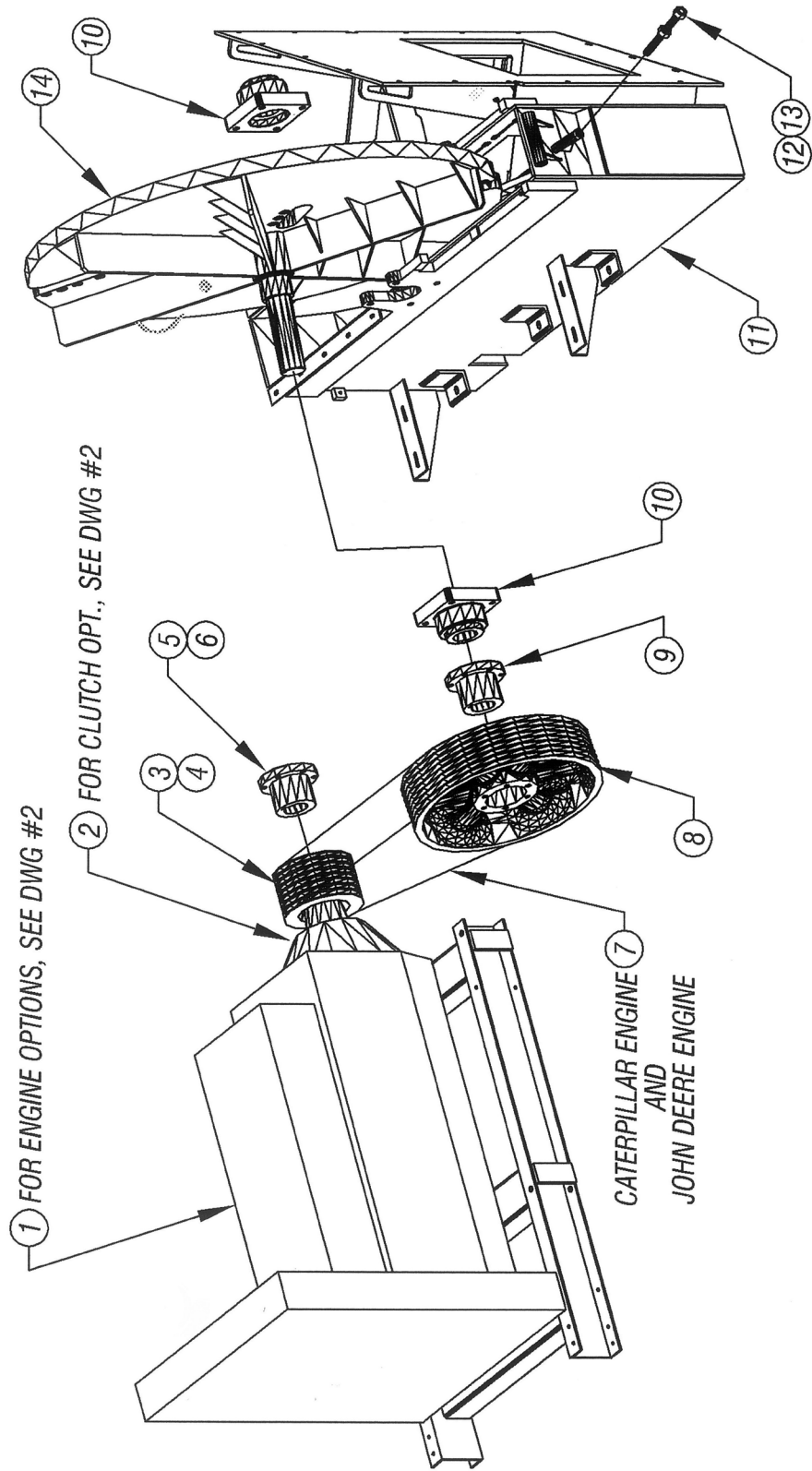

813 CHIPPER - DWG #10

ISSUED: 07-12-2010

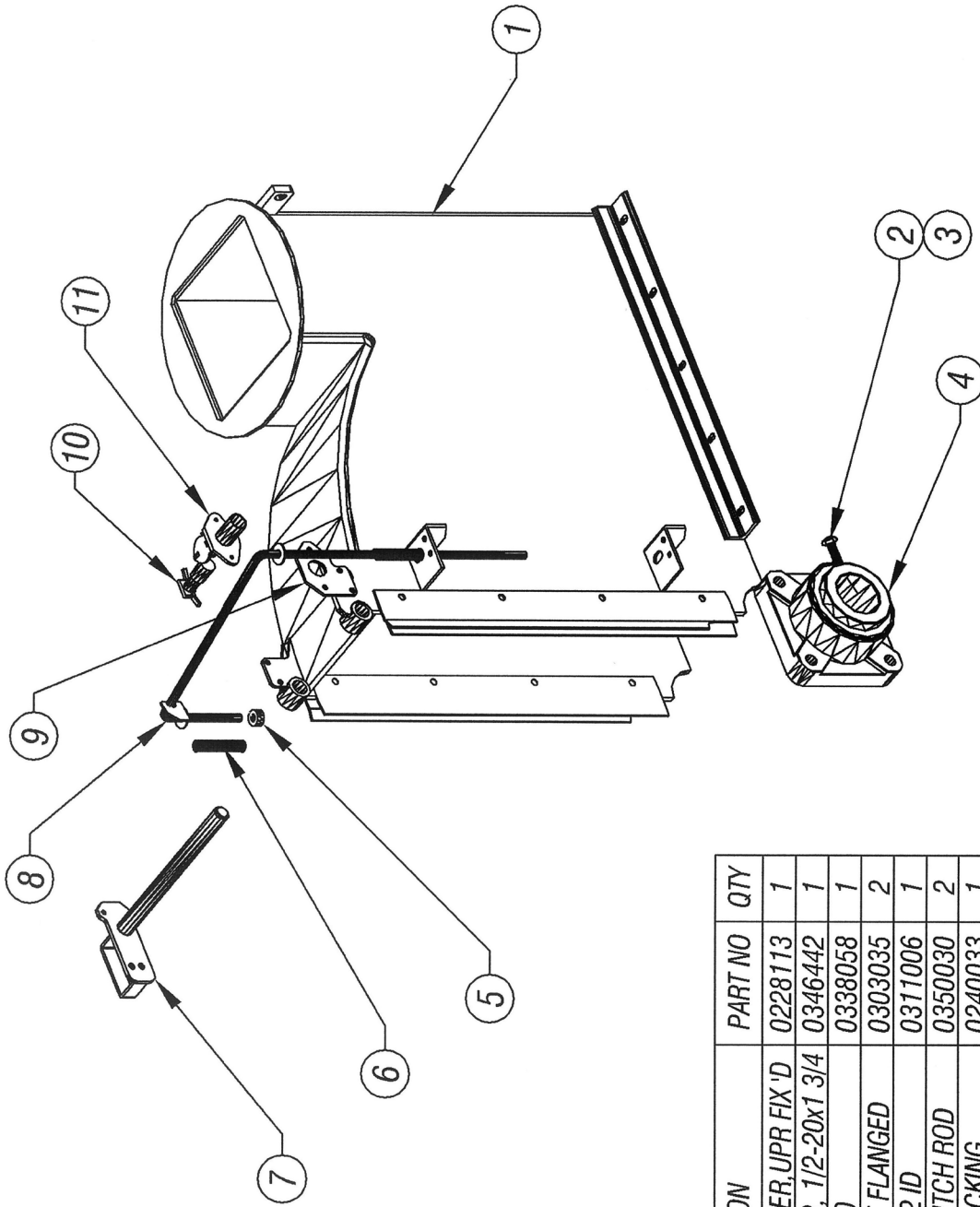

813 CHIPPER - DWG #11

ITEM	DESCRIPTION	PART NO	QTY
1	HOUSING, IMPELLER, UPR FIX 'D	0228113	1
2	SOC HD CAP SCR, 1/2-20x1 3/4	0346442	1
3	JAM NUT, 1/2 - 20	0338058	1
4	BEARING, 4-BOLT FLANGED	0303035	2
5	COLLAR, SET - 1/2 ID	0311006	1
6	SPRING, KILL SWITCH ROD	0350030	2
7	PIN, HOUSING LOCKING	0240033	1
8	ROD, KILL SWITCH ACTIVATING	0245123	1
9	BRKT, ENGINE KILL MOUNT 'G	0406577	1
10	SAFETY SWITCH, MALE	0315070	1
11	SAFETY SWITCH, FEMALE	0315242	1

ISSUED: 07-12-2010

ITEM	DESCRIPTION	PART NO	QTY
1	BOX, TAILLIGHT - CENTER	0280025	1
2	LIGHT, 3-BAR (SEALED)	0315238	1
3	TAILLIGHT ASSY - OBLONG SEALED BEAM	0315237	4
4	BOX, TAILLIGHT - DUAL OBLONG LENS	0280026	2
5	MOUNT, TAILLIGHT ASSY	0276383	2

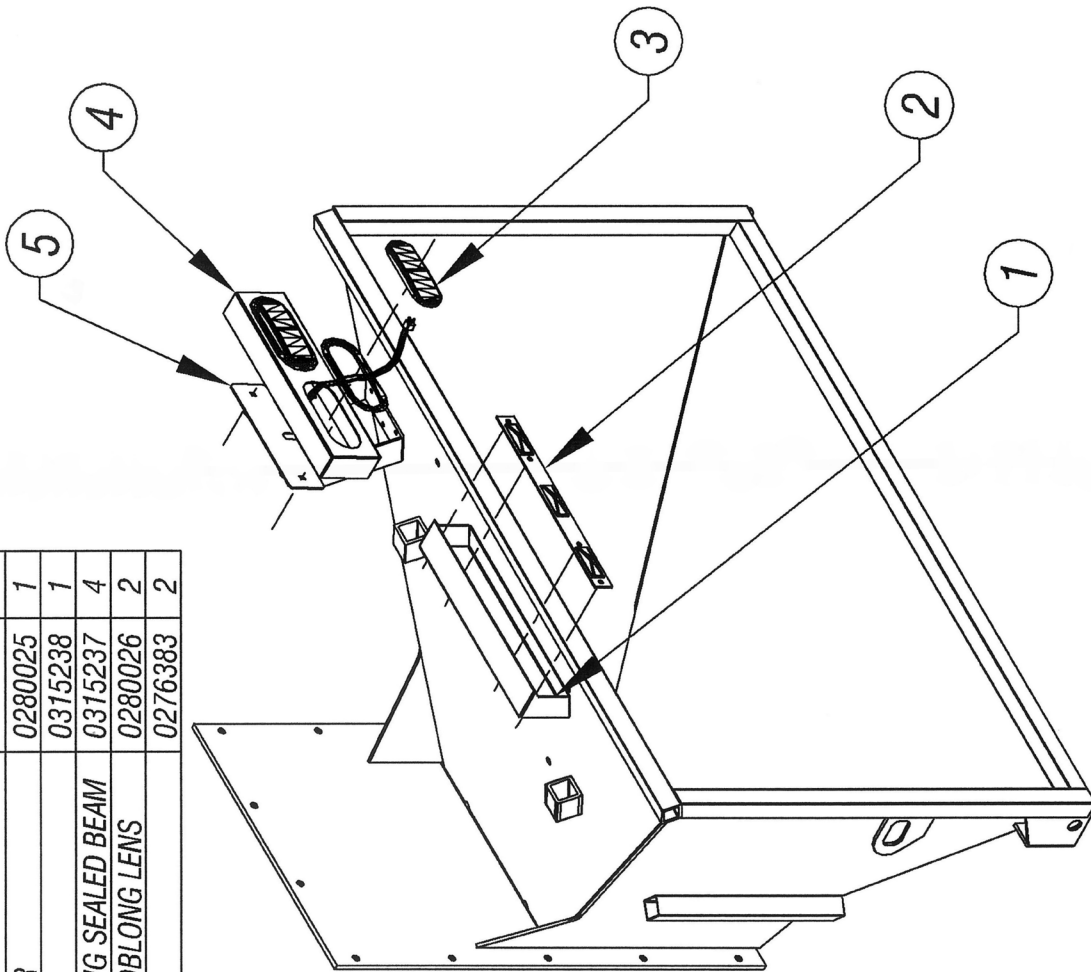

OPTION #0161146 - SAFETY LIGHT (IN-FEED CHUTE MOUNT)
813 CHIPPER - DWG #12

http

ISSUED: 07-12-2010

ITEM	DESCRIPTION	PART NO	QTY
1	HOUSING, IMPELLER- LOWER	0228267	1
2	PIN, HOUSING LOCK- UPPER	0240033	1
3	HSG, IMPEL- UPR REMOVABLE	0228114	1
4	HOUSING, IMPL - UPR FIXED	0228113	1
5	ROD, KILL SWITCH ACTIVATING	0245123	1

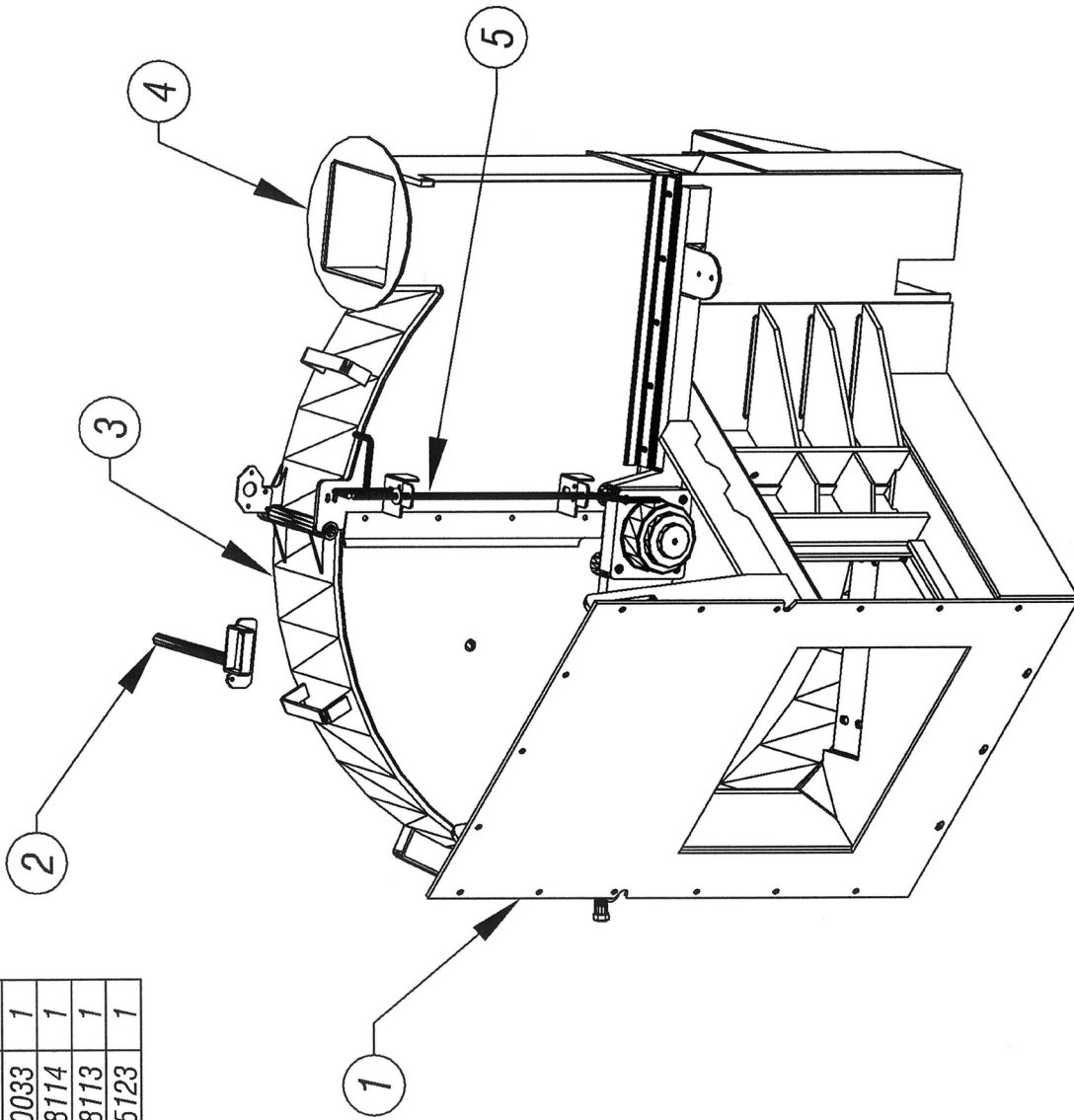

813 CHIPPER - DWG #13

ITEM	DESCRIPTION	PART NO	QTY	ITEM	DESCRIPTION	PART NO	QTY
1	TONGUE, TOW FRAME	0225080	1	7	SAFETY CHAIN	0309056	2
2	JACK MOUNTING BRACKET	0269019	1	8	CONNECTOR, TRAILER END	0315065	1
3	BREAK-A-WAY SWITCH	0302030	1	9	JACK, 10000 LB - DROP LEG	0369032	1
4	PINTLE RING, SQUARE BASE	0325077	1	10	JACK, 15" TRAVEL - SIDE WIND	0369005	1
5	COUPLER, 2-5/16 - SQUARE BASE	0325087	1	11	CASTER WHEEL	0354113	1
6	SAFETY HOOK	0309057	2	12	JACK, TOP WIND - REAR JACK	0369006	1

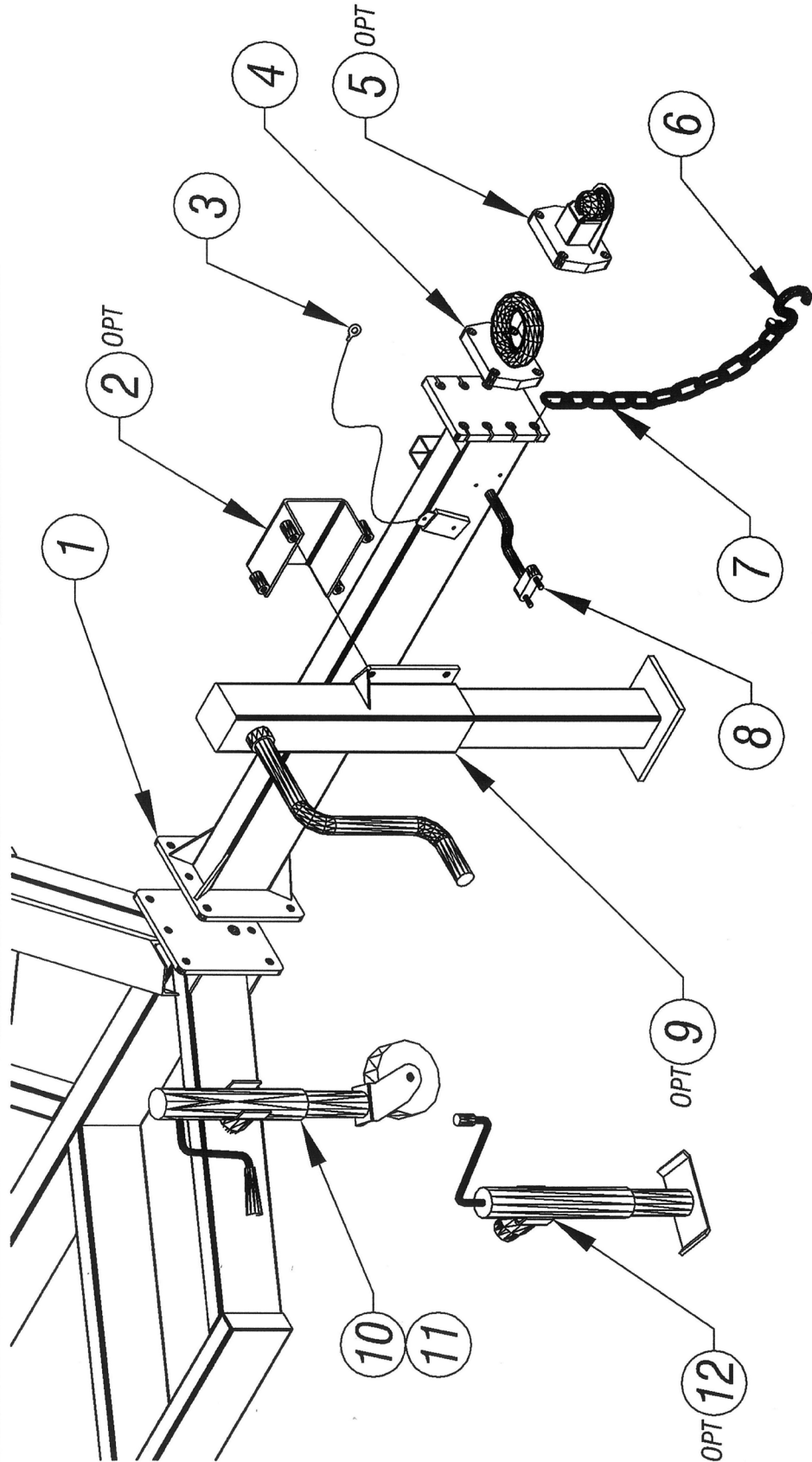

813XT CHIPPER - DWG #14

http:

ISSUED: 07-12-2010

ITEM	DESCRIPTION	PART NO	QTY
1	BLADE, CHIPPER IMPELLER	0305047	4
2	BLADE, VERTICAL BED KNIFE	0405049	1
3	BLADE, HORIZONTAL BED KNIFE	0405050	1

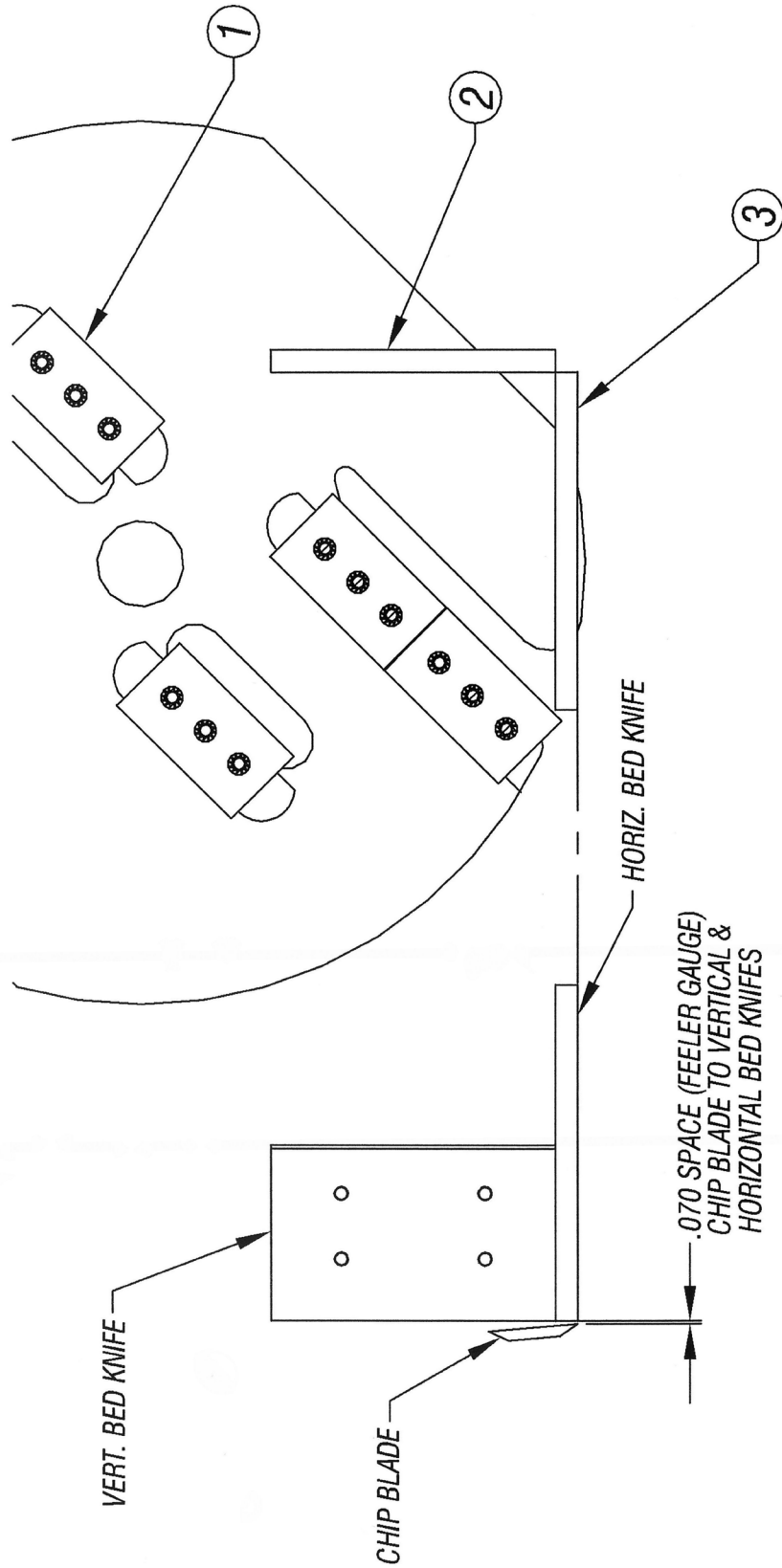

BED KNIFE ADJUSTMENT
813 CHIPPE - DWG #15

ITEM	DESCRIPTION	PART NO	QTY
1	HOLDER, STROBE LIGHT-UPPER	0281050	1
2	THRUST WASHER	0453311	1
3	HOLDER, STROBE LIGHT-LOWER	0281051	1
4	CLEVIS PIN	0340088	1
5	HITCH PIN	0340006	1
6	STROBE LIGHT	0315130	1

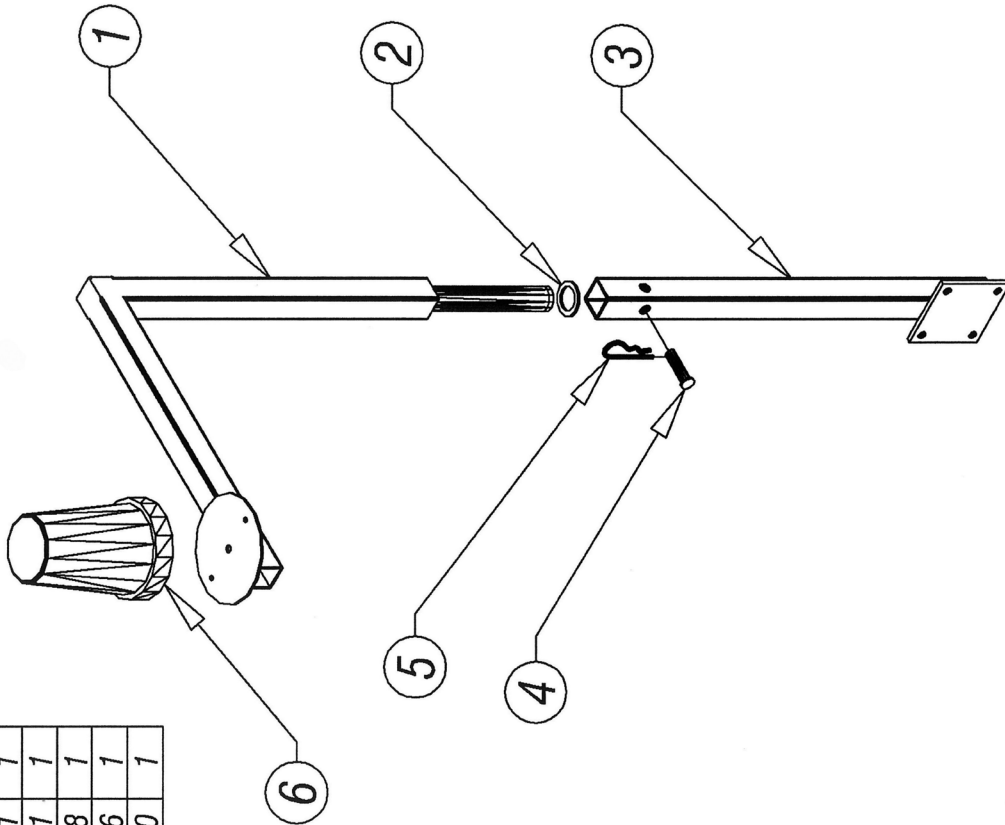

PIVOTING STROBE LIGHT- OPTION #0161138
813 CHIPPER - DWG #16

ISSUED: 07-12-2010
 ISSUED: 10-24-2012

ITEM	DESCRIPTION	PART NO	QTY
1	COVER, SPEED SENSING SPROCKET	0471219	1
2	BRACKET, SPEED SENSING MOUNT	0206641	1
3	MAGNETIC PICK-UP	0315128	1
4	SPROCKET, SPEED SENSING	0451219	1
5	LOCK WASHER	0353005	1
6	HEX HEAD SCREW, 1/2-13 x 1.5 LG	0346404	1

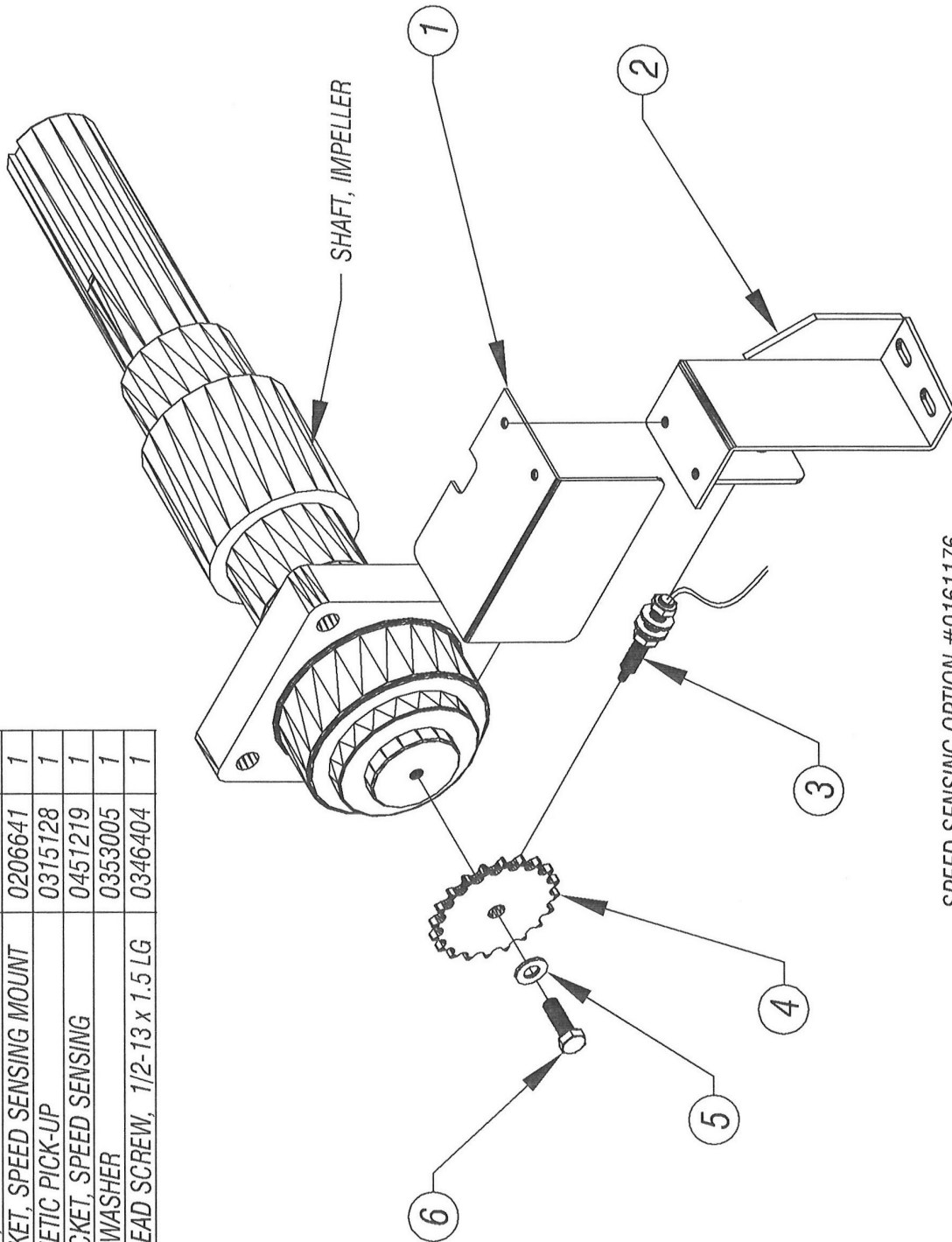

SPEED SENSING OPTION #0161176
 813 CHIPPER - DWG #17

ISSUED: 07-12-2010

ITEM	DESCRIPTION	PART NO	QTY
1	TACHOMETER WITH WIRING HARNESS	0315250	1
2	MAGNETIC PICK-UP	0315128	1
3	SOLENOID VALVE, NORMALLY OPEN	0330080	1
4	SOLENOID VALVE, NORMALLY CLOSED	0330081	1

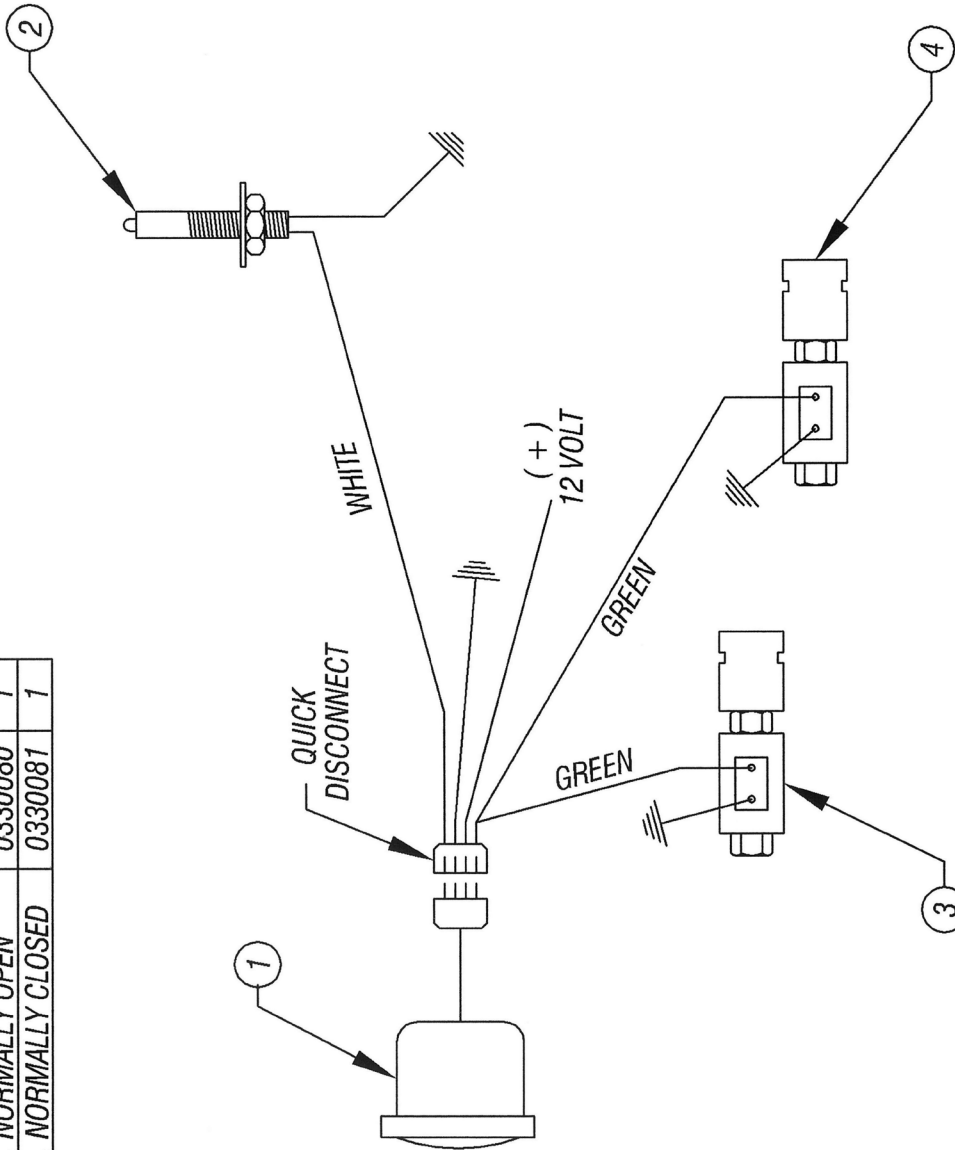

WIRING DIAGRAM FOR SPEED SENSING
(WITHOUT AUTO REVERSE)

813 CHIPPER - DWG #18

ISSUED: 07-12-2010

ITEM	DESCRIPTION	DWG NO	QTY
1	CHUTE, FIXED HEIGHT EXHAUST	0226115	1
2	WING NUT	0238500	1
3	LOCK WASHER, SPLIT	0353005	1
4	BOLT, CARRIAGE	0346429	4
5	FLAT WASHER	0353104	4
6	NUT, NYLON LOCK	0338104	3
7	CHUTE, DEFLECTOR	0426028	1
8	SUPPORT, EXHAUST CHUTE	0477132	1
9	SUPPORT, PIVOT JACK	0277131	1
10	CLAMP, FRONT HALF	0210107	1

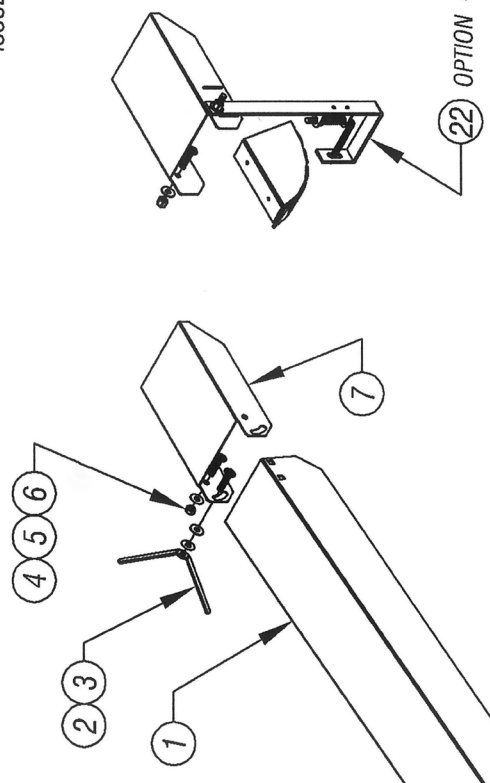

22 OPTION # 161143

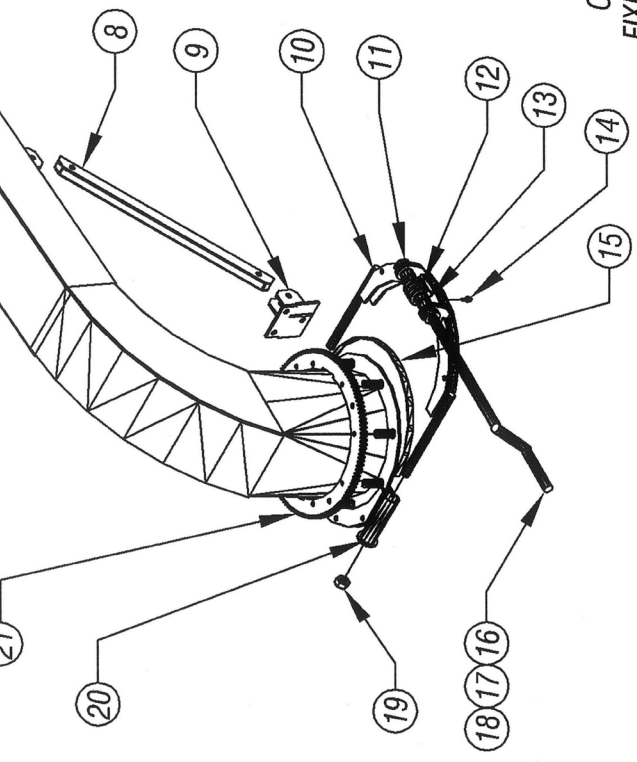

ITEM	DESCRIPTION	DWG NO	QTY
11	COLLER, SET	0311038	2
12	GEAR, WORM-HELIX	0363011	1
13	SPACER, D.O.M.-1 1/8" OD x .125" WALL x 1 7/16" LONG		2
14	GREASE FITTING	0317001	2
15	WEAR STRIP, TEFLON	0436117	2
16	BUSHING, BRONZE	0407034	2
17	KEY	0331009	1
18	HANDLE, CRANK CHUTE ROTATION	0223097	1
19	LOCK NUT	0338106	2
20	CLAMP, REAR HALF	0210106	1
21	SPROCKET, DRIVE CHUTE ROTATION	0251117	1
22	QUICK ADJUSTMENT CHUTE DEFLECTOR	0161143	1

OPTION #0161147 - DISCHARGE CHUTE
FIXED HEIGHT WITH HAND CRANK ROTATION
813 CHIPPER - DWG #19

ISSUED: 07-12-2010

ITEM	DESCRIPTION	DWG NO	QTY
1	CHUTE, HEIGHT ADJUSTABLE EXHAUST	0226102	1
2	WING NUT	0238500	1
3	LOCK WASHER, SPLIT	0353005	1
4	BOLT, CARRIAGE	0346429	4
5	FLAT WASHER	0353104	4
6	NUT, NYLON LOCK	0338104	3
7	CHUTE, DEFLECTOR	0426028	1
8	JACK, EXHAUST HEIGHT LIFTING	0269031	1
9	SUPPORT, PIVOT JACK	0277127	1
10	CLAMP, REAR HALF	0210070	1

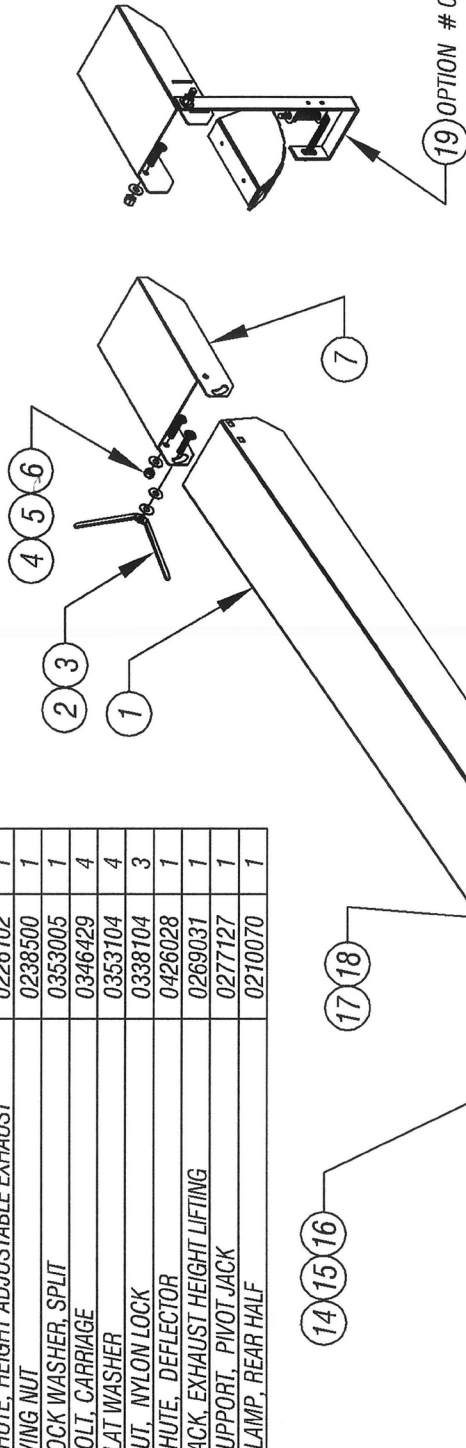

ITEM	DESCRIPTION	DWG NO	QTY
11	CLAMP, FRONT HALF	0210067	1
12	NUT, WING - 3/4-10	0238501	2
13	CLAMP STRIP - RUBBER - 1/8x3/8x14 (BULCK)	0356045	1
14	BOLT	0346403	1
15	LOCK WASHER	0353005	1
16	FLAT WASHER	0453741	1
17	GREASE FITTING, 1/8 NPT	0317083	1
18	PIN, HINGE- WELDMENT	0224011	1
19	QUICK ADJUSTMENT DEFLECTOR CHUTE	0161143	1

OPTION #0161139 - DISCHARGE CHUTE
 (HAND CRANK HEIGHT ADJ. WITH STANDARD ROTATION)
 813 CHIPPER - DWG #20

ITEM	DESCRIPTION	DWG NO	QTY
1	CHUTE, HEIGHT ADJUSTABLE EXHAUST	0226157	1
2	WING NUT	0238500	1
3	LOCK WASHER, SPLIT	0353005	1
4	BOLT, CARRIAGE	0346429	4
5	FLAT WASHER	0353104	4
6	NUT, NYLON LOCK	0338104	3
7	CHUTE, DEFLECTOR	0426028	1
8	JACK, EXHAUST HEIGHT LIFTING	0269031	1
9	SUPPORT, PIVOT JACK	0277127	1
10	CLAMP, FRONT HALF	0210107	1

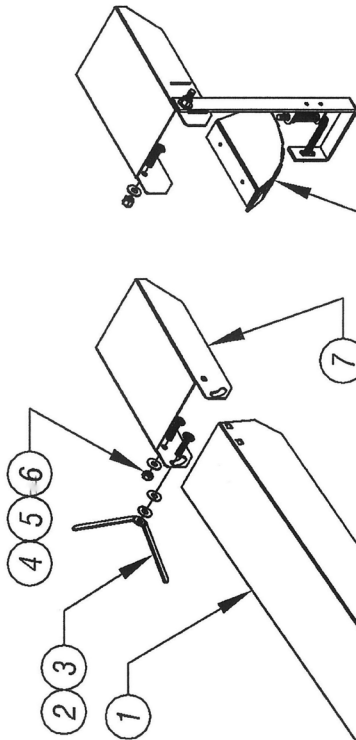

27 OPTION # 0161143
QUICK ADJUSTMENT DEFLECTOR CHUTE

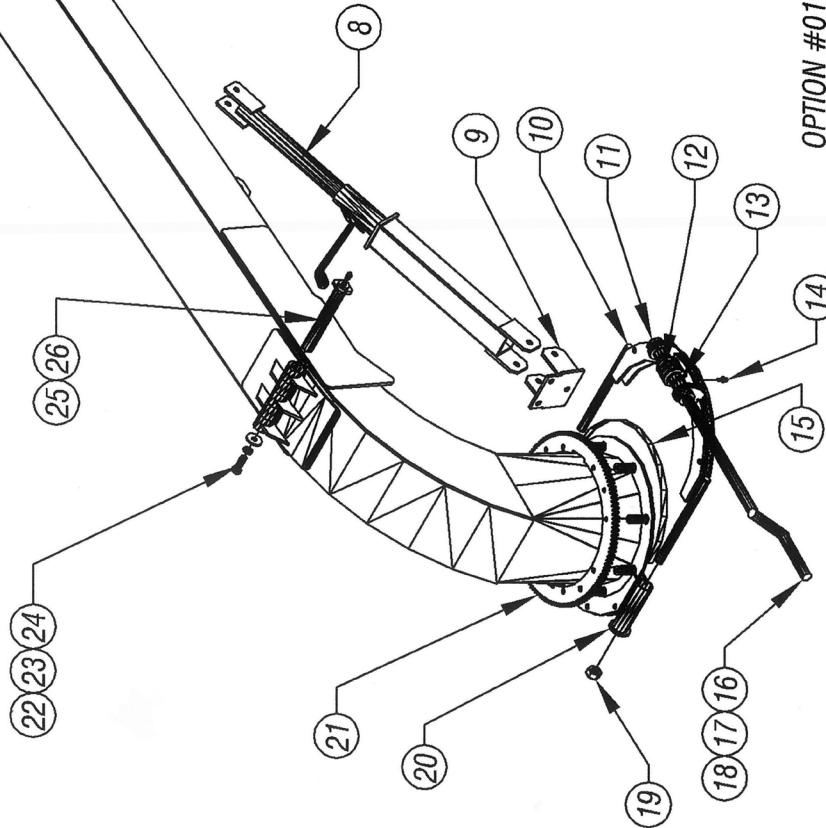

ITEM	DESCRIPTION	DWG NO	QTY
11	COLLAR, SET	0311038	2
12	GEAR, WORM- HELIX	0363011	1
13	SPACER, D.O.M.- 1 1/8" OD x 1/8" WALL x 1 7/16" LONG		2
14	GREASE FITTING	0317001	2
15	WEAR STRIP, TEFLON	0436117	2
16	HANDLE, CRANK CHUTE ROTATION	0323097	1
17	KEY	0431009	1
18	BUSHING, BRONZE	0407034	2
19	LOCK NUT	0338106	2
20	CLAMP, REAR HALF	0210106	1
21	SPROCKET, DRIVE CHUTE ROTATION	0251117	1
22	BOLT	0346403	1
23	LOCK WASHER	0353005	1
24	FLAT WASHER	0453141	1
25	GREASE FITTING, 1/8 NPT	0317083	1
26	PIN, HINGE- WELDMENT	0224011	1
27	QUICK ADJUSTMENT DEFLECTOR CHUTE	0161143	1

OPTION #0161142 - DISCHARGE CHUTE
HAND CRANK HEIGHT ADJ. WITH HAND CRANK ROTATION
813 CHIPPER - DWG #21

ISSUED: 07-12-2010

0148212- WINCH REEL ASSY
FOR DETAIL, SEE DWG #23

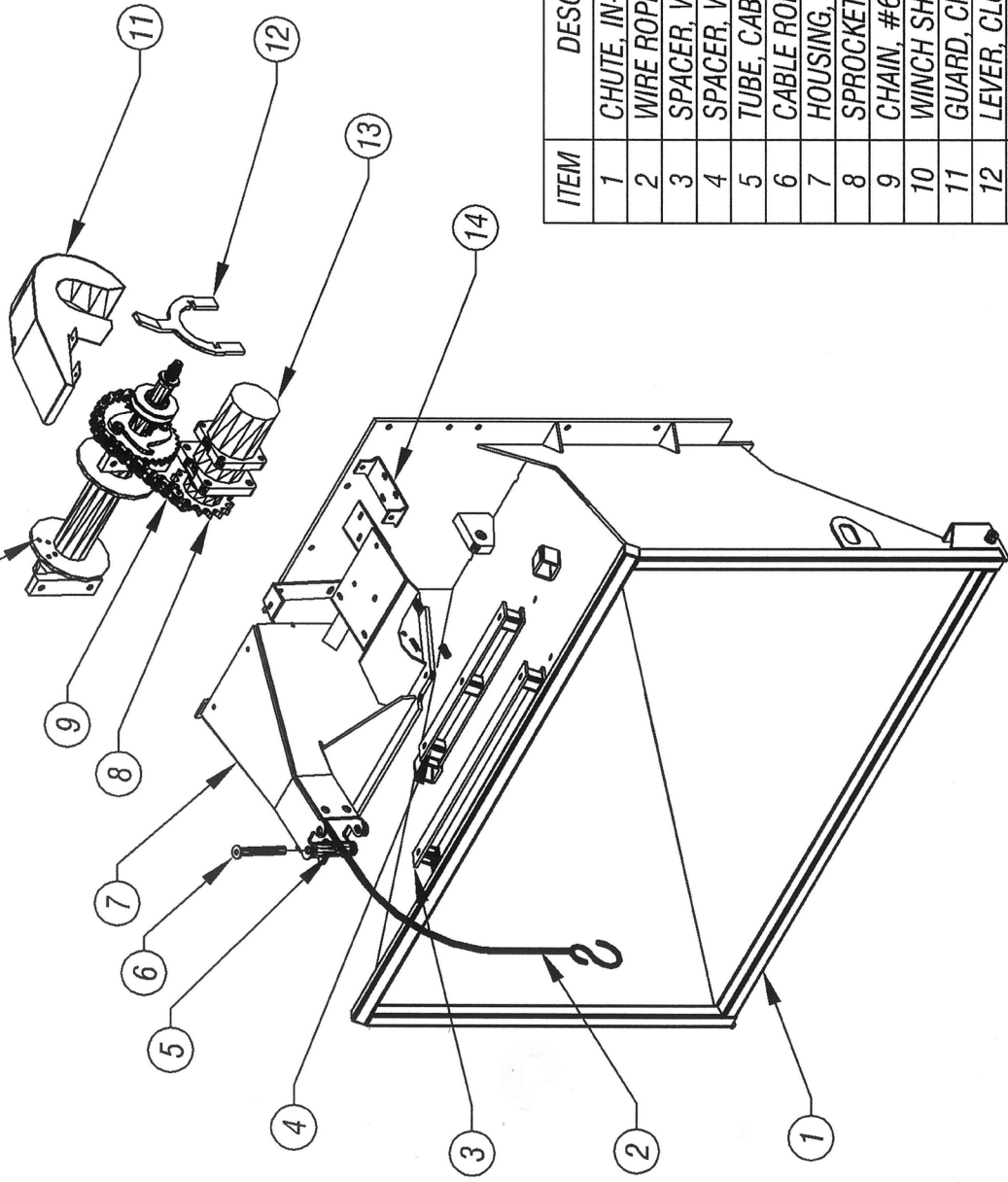

ITEM	DESCRIPTION	PART NO	QTY
1	CHUTE, IN-FEED	0226150	1
2	WIRE ROPE WITH HOOK	0330122	1
3	SPACER, WINCH M/TG- REAR	0249200	1
4	SPACER, WINCH M/TG- FRONT	0249199	1
5	TUBE, CABLE ROLLER	0467313	4
6	CABLE ROLL PIN	0240112	4
7	HOUSING, WINCH	0228242	1
8	SPROCKET, WINCH MOTOR	0351134	1
9	CHAIN, #60 (BULK, TO FIT)	0309048	1
10	WINCH SHAFT ASSY	0148212	1
11	GUARD, CHAIN	0221419	1
12	LEVER, CLUCH NEUTRAL	0233173	1
13	MOTOR, WINCH	0330143	1
14	BRACKET, MOUNT N. LEVER	0406718	1

OPTION #0161209 - HIGH SPEED WINCH
813 CHIPPER DWG #22

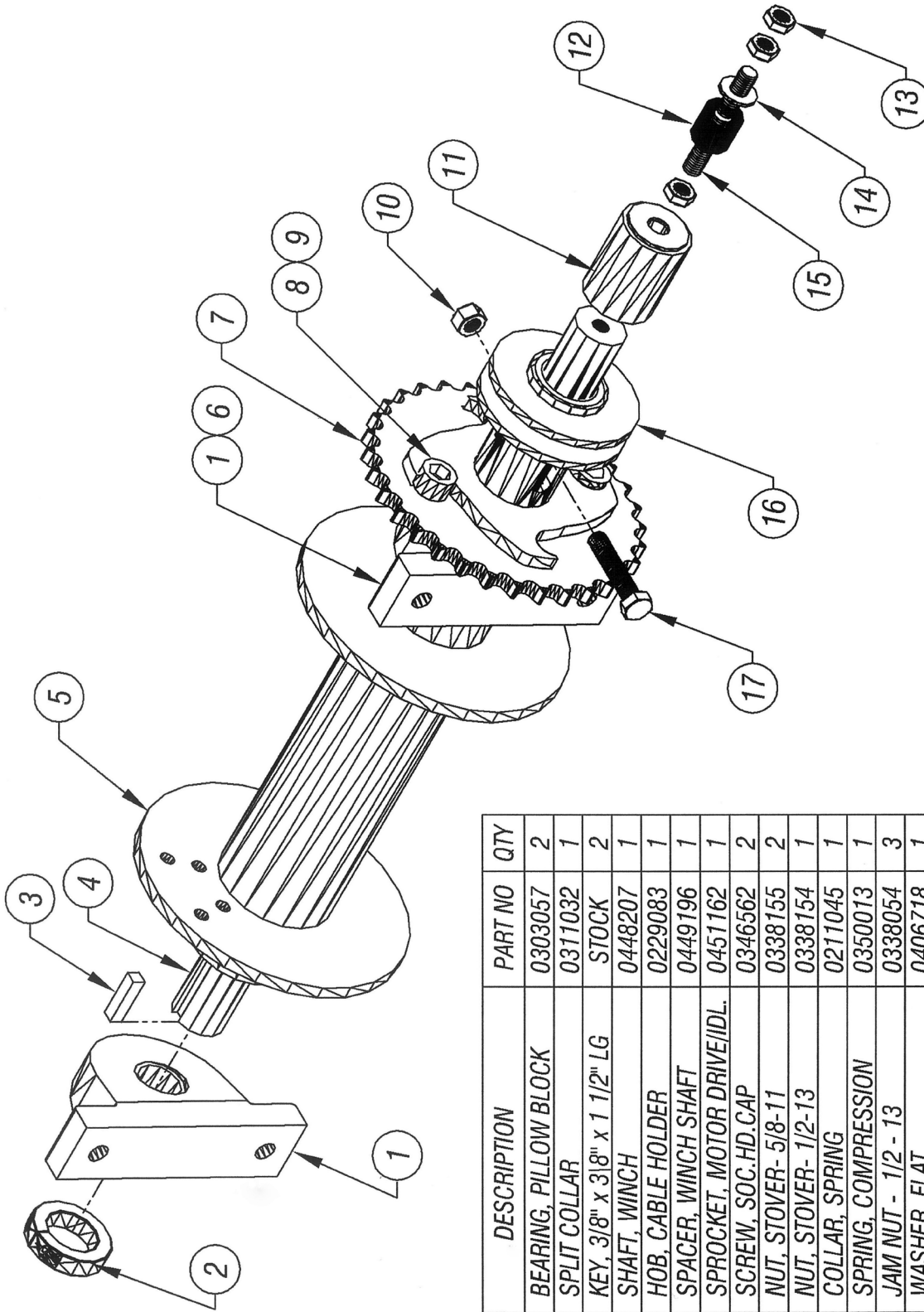

ITEM	DESCRIPTION	PART NO	QTY
1	BEARING, PILLOW BLOCK	0303057	2
2	SPLIT COLLAR	0311032	1
3	KEY, 3/8" x 3/8" x 1 1/2" LG	STOCK	2
4	SHAFT, WINCH	0448207	1
5	HOB, CABLE HOLDER	0229083	1
6	SPACER, WINCH SHAFT	0449196	1
7	SPROCKET, MOTOR DRIVE/IDL.	0451162	1
8	SCREW, SOC.HD.CAP	0346562	2
9	NUT, STOVER-5/8-11	0338155	2
10	NUT, STOVER-1/2-13	0338154	1
11	COLLAR, SPRING	0211045	1
12	SPRING, COMPRESSION	0350013	1
13	JAM NUT - 1/2 - 13	0338054	3
14	WASHER, FLAT	0406718	1
15	THREADED ROD- 1/2-13 x 3.5	STOCK	1
16	HUB, CLUTCH ASSY	0229085	1
17	ROIT HFX HD - 1/2-13 x 2 3/4"	0346435	1

OPTION #0161209 - HIGH SPEED WINCH
813 CHIPPER - DWG #23

ISSUED: 02-24-2012
 ISSUED: 06-17-2013

ITEM	PART DESCRIPTION	PART #	QTY	ITEM	PART DESCRIPTION	PART #	QTY	ITEM	PART DESCRIPTION	PART #	QTY
1	OIL TANK, HYDRAULIC	0252025	1	8	CONNECTOR, 1/2 FLR x 3/8 O-RING	0317066	2	15	90° ELBOW, 1/2 FLARE x 5/8 O-RING	0317008	1
2	CONNECTOR, 5/8 FLARE x 3/4 MPT	0317262	1	9	VALVE, DIRECTIONAL, FEED ROLL	0330203	1	16	HOSE, PUMP / VALVE, 1/2 ID x 85"	0327251	1
3	HOSE, FILLER / TANK, 5/8 ID x 24"	0327373	1	10	CONNECTOR, 1/2 FLR x 1/2 O-RING	0317030	2	17	CONNECTOR, 1/2 FLR x 5/8 O-RING	0317027	1
4	90° ELB, 5/8 FLARE x 3/4 ID O-RING	0317214	1	11	HOSE, VALVE/MOTOR, 1/2 ID x 64"	0327145	1	18	PUMP, LIVE HYDRAULIC	0330168	1
5	90° ELB, 1/2 FLARE x 3/4 ID O-RING	0317079	1	12	HOSE, VALVE/MOTOR, 1/2 ID x 66"	0327144	1	19	STRT ADAPTR, 1" TUBE x 3/4 O-RING	0317129	1
6	OIL FILTER, HOUSING	0318022	1	13	45° ELBOW, 1/2 FLR x 5/8 O-RING	0317247	1	20	NOSE, PUMP / TANK, 1" ID x 60"	BULK	1
7	HOSE, FILTER / VALVE, 1/2 ID x 20"	0327142	1	14	MOTOR, FEED ROLL	0330144	1	21	90° ADAPTER, 1" TUBE x 1" MPT	0317081	1

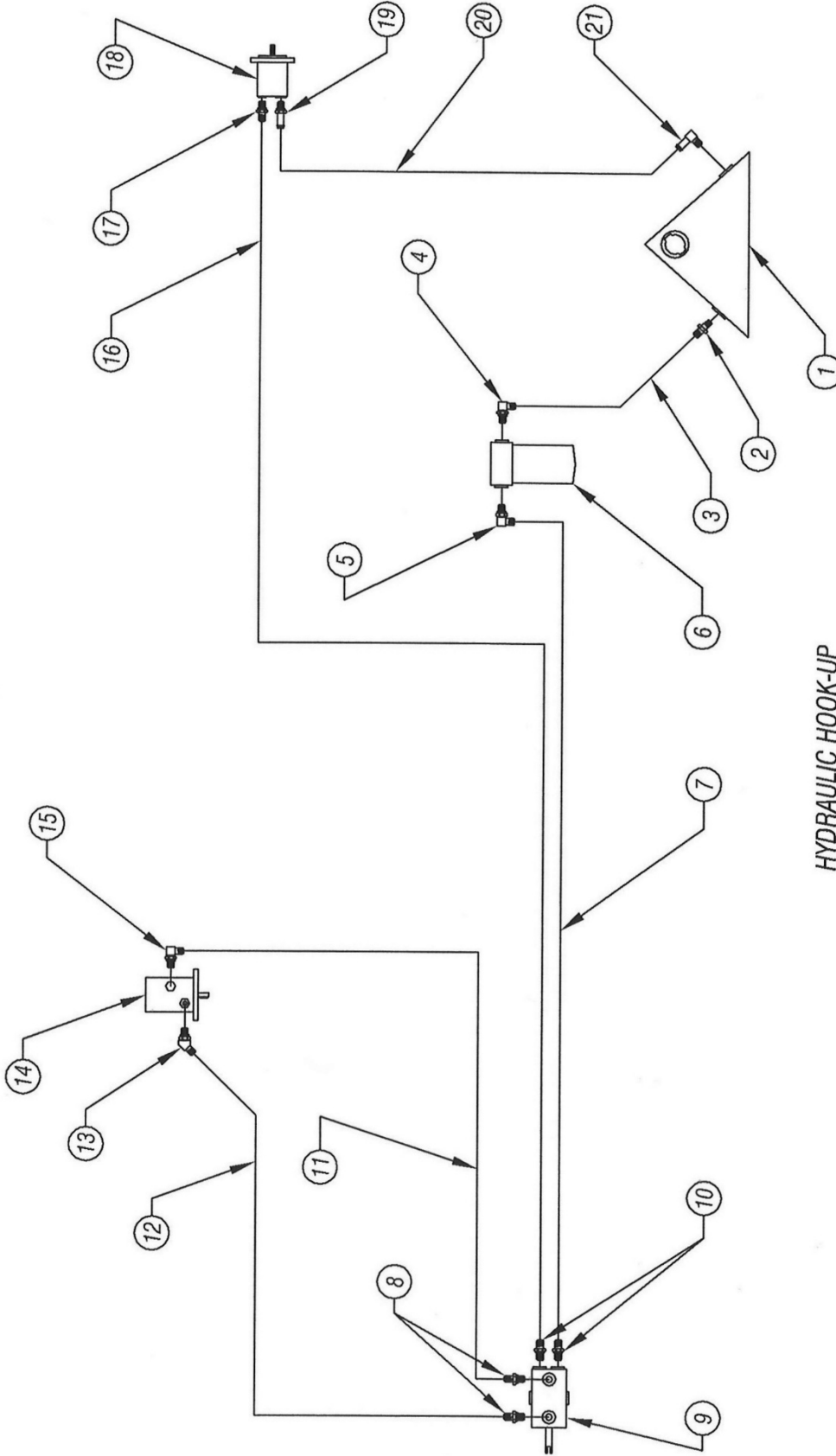

HYDRAULIC HOOK-UP
 JOHN DEERE ENGINE - BASE CHIPPER
 813 CHIPPER - DWG #1

ITEM	PART DESCRIPTION	PART#	QTY
1	HYD OIL TANK	0252025	1
2	OIL FILTER, HOUSING	0318022	1
3	VALVE, DIRECTIONAL- FD ROLL	0330203	1
4	VALVE, SOLENOID-NORM OPEN	0330080	1
5	VALVE, SOLENOID-NORM. CL'D	0330081	1
6	MOTOR, FEED ROLL	0330144	1
7	PUMP, LIVE HYD	0330168	1

HYDRAULIC COMPONENTS

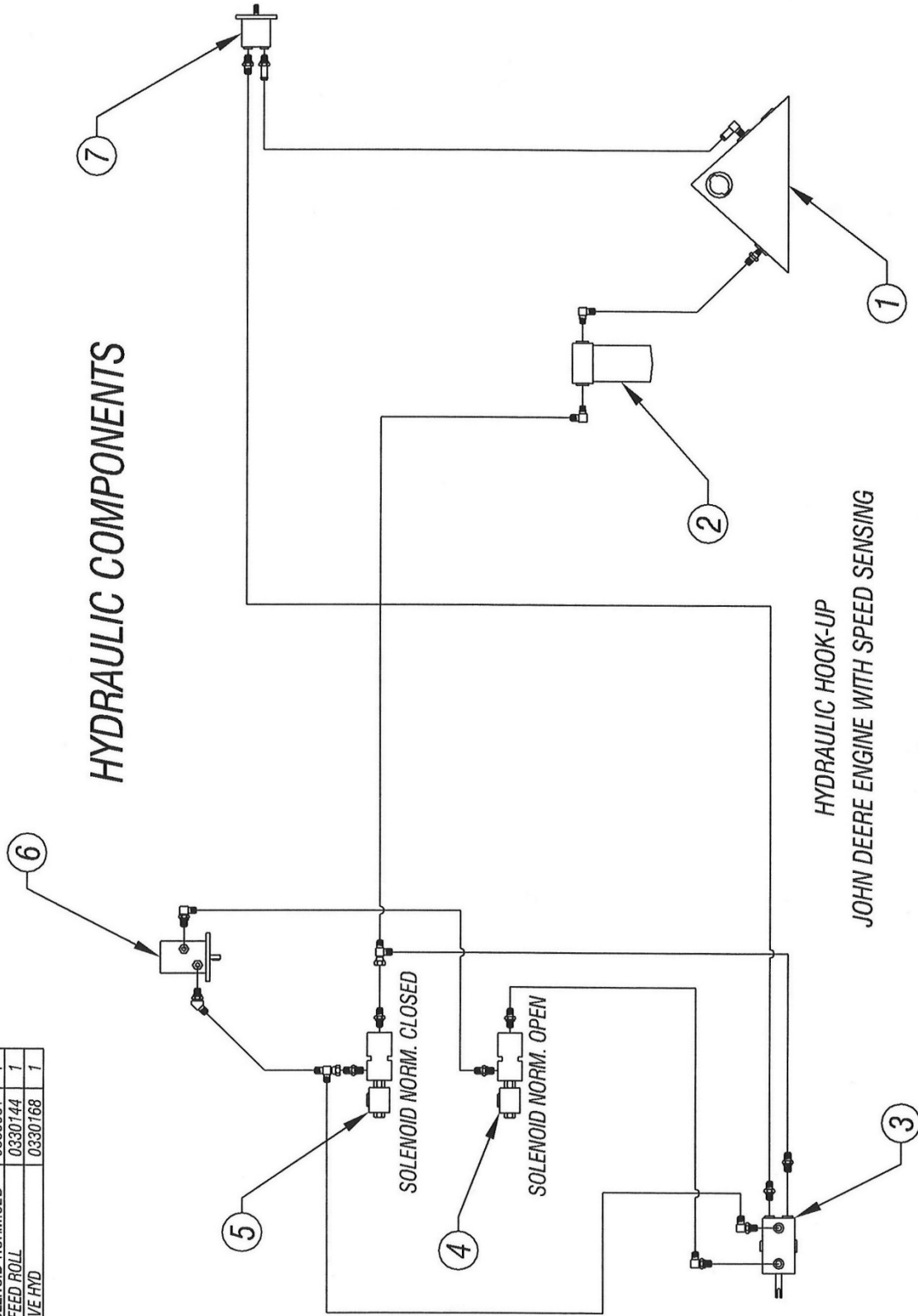

HYDRAULIC HOOK-UP
JOHN DEERE ENGINE WITH SPEED SENSING

813 CHIPPER - DWG #2A

ITEM	PART DESCRIPTION	PART#	QTY	ITEM	PART DESCRIPTION	PART#	QTY
1	CONNECTOR, 1/2 FL x 5/8 O-RING	0317027	1	7	CONNECTOR, 1/2 FL x 1/2 O-RING	0317030	2
2	ADAPTER, 1" TUBE x 3/4 O-RING	0317129	1	8	90° ELBOW, 1/2 FL x 3/8 O-RING	0317064	2
3	90° ADAPTER, 1" TUBE x 1" MPT	0317081	1	9	CONNECT., 1/2 FL x 3/8 O-RING	0317066	2
4	CONNECTOR, 5/8 FL x 3/4 MPT	0317262	1	10	SWIVEL TEE RUN, 1/2 x 1/2 x 1/2	0317118	2
5	90° ELBOW, 5/8 FL x 3/4 O-RING	0317214	1	11	CONNECT., 1/2 FL x 1/2 O-RING	0317030	2
6	90° ELBOW, 1/2 FL x 3/4 O-RING	0317079	1	12	45° ELBOW, 1/2 FL x 5/8 O-RING	0317247	1
				13	90° ELBOW, 1/2 FL x 5/8 O-RING	0317008	1

HYDRAULIC FITTINGS

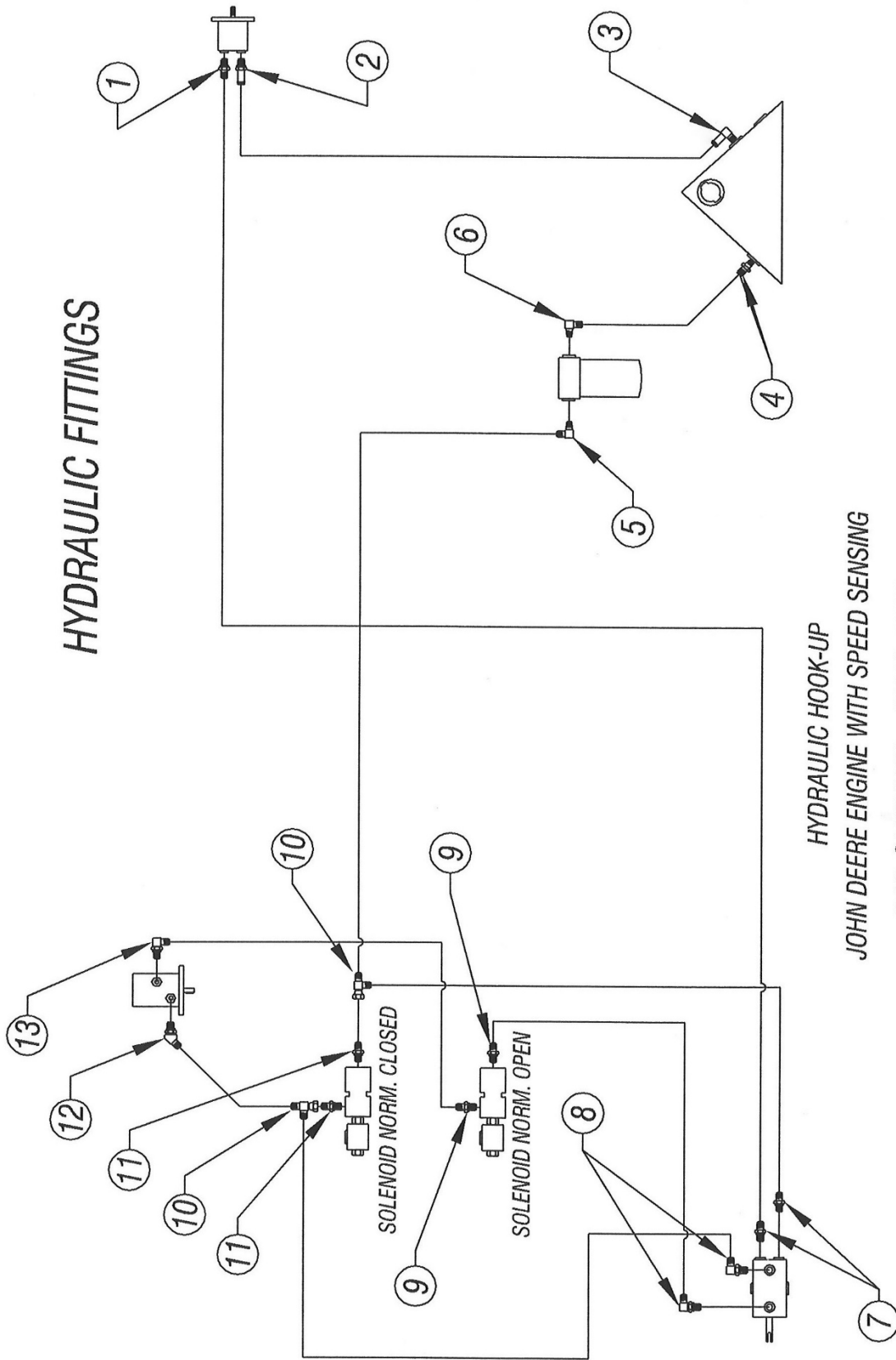

HYDRAULIC HOOK-UP
 JOHN DEERE ENGINE WITH SPEED SENSING
 813 CHIPPER - DWG #2B

ITEM	PART DESCRIPTION	PART #	QTY	ITEM	PART DESCRIPTION	PART #	QTY
1	VALVE TO PUMP, 1/2 ID X 85"	0327355	1	6	SOL. N/O TO R. VALVE, 1/2 ID X 18"	0327076	1
2	PUMP TO TANK, 1" ID X FIT	BULK	1	7	VALVE TO SOL. N/C, 1/2 ID X 22"	0327099	1
3	FILTER TO TANK, 5/8 ID X 24"	0327373	1	8	SOL. N/C TO MOTOR, 1/2 ID X 64"	0327145	1
4	SOL. N/C TO FILTER, 1/2 ID X 20"	0327142	1	9	SOL. N/O TO MOTOR, 1/2 ID X 66"	0327144	1
5	SOL. N/C TO VALVE, 1/2 ID X 20"	0327090	1				

HYDRAULIC HOSES

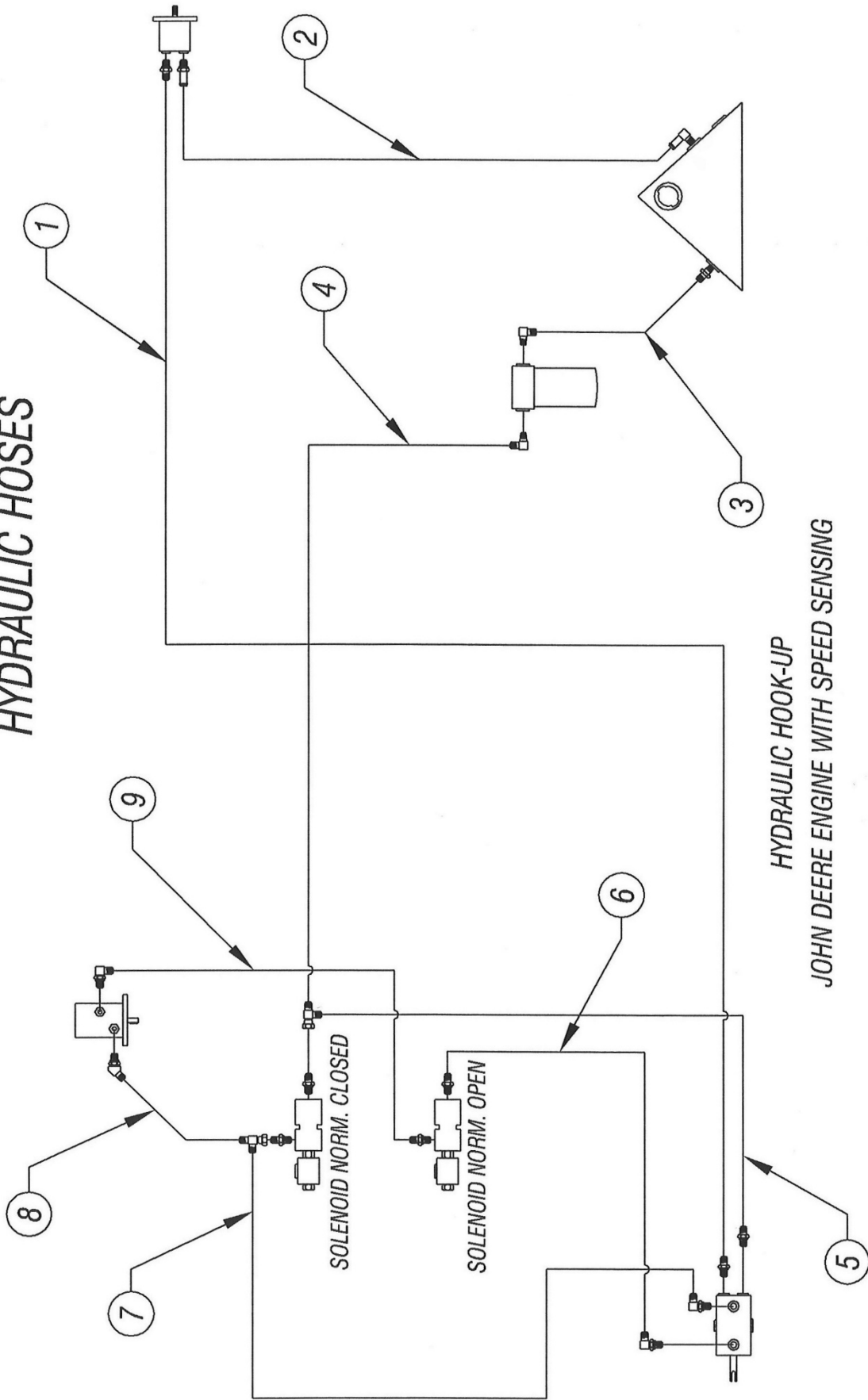

HYDRAULIC HOOK-UP
JOHN DEERE ENGINE WITH SPEED SENSING

813 CHIPPER - DWG #2C

ITEM	PART DESCRIPTION	PART #	QTY
6	PUMP, LIFE HYD	0330168	1
7	OIL FILTER, HOUSING	0318022	1
8	HYD OIL TANK	0252025	1
9	VALVE, DIRECTIONAL- FD ROLL	0330162	1

ITEM	PART DESCRIPTION	PART #	QTY
1	VALVE, DIRECTIONAL-LIFT CYL.	0330126	1
2	HYDRAULIC CYLINDER	0330046	2
3	PLT. YOKE CYL DOWNFORCE	0262188	2
4	MOUNT. CYL. CLAMP	0276139	2
5	MOTOR, FEED ROLL	0330144	1

HYDRAULIC COMPONENTS

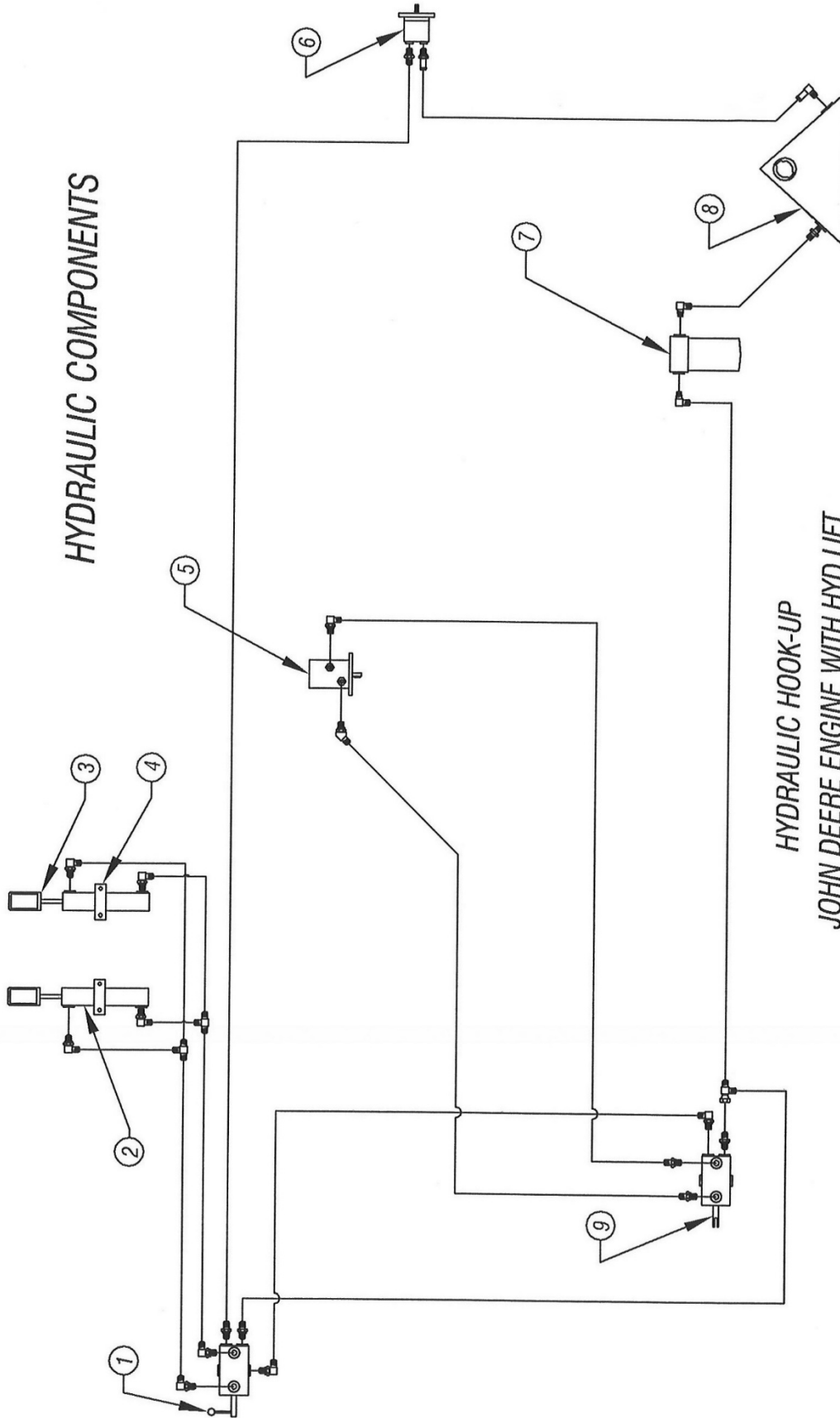

HYDRAULIC HOOK-UP
 JOHN DEERE ENGINE WITH HYD LIFT

813 CHIPPER - DWG #3A

ITEM	PART DESCRIPTION	PART #	QTY
1	HYDRAULIC OIL TANK	0252025	1
2	OIL FILTER, HOUSING	0318022	1
3	VALVE, DIRECTIONAL- FEED ROLL	0330203	1
4	VALVE, SOLENOID - NORM. OPEN	0330080	1
5	VALVE, SOLENOID - NORM. CLOSED	0330081	1
6	MOTOR, FEED ROLL	0330144	1
7	VALVE, DIRECTIONAL- LIFT CYLINDER	0330126	1
8	MOUNT, CYLINDER CLAMP	0276139	2
9	HYDRAULIC CYLINDER	0330046	2
10	PLATE, YOKE CYLINDER DOWNFORCE	0262188	2
11	PUMP, LIVE HYDRAULICS	0330088	1

HYDRAULIC COMPONENTS

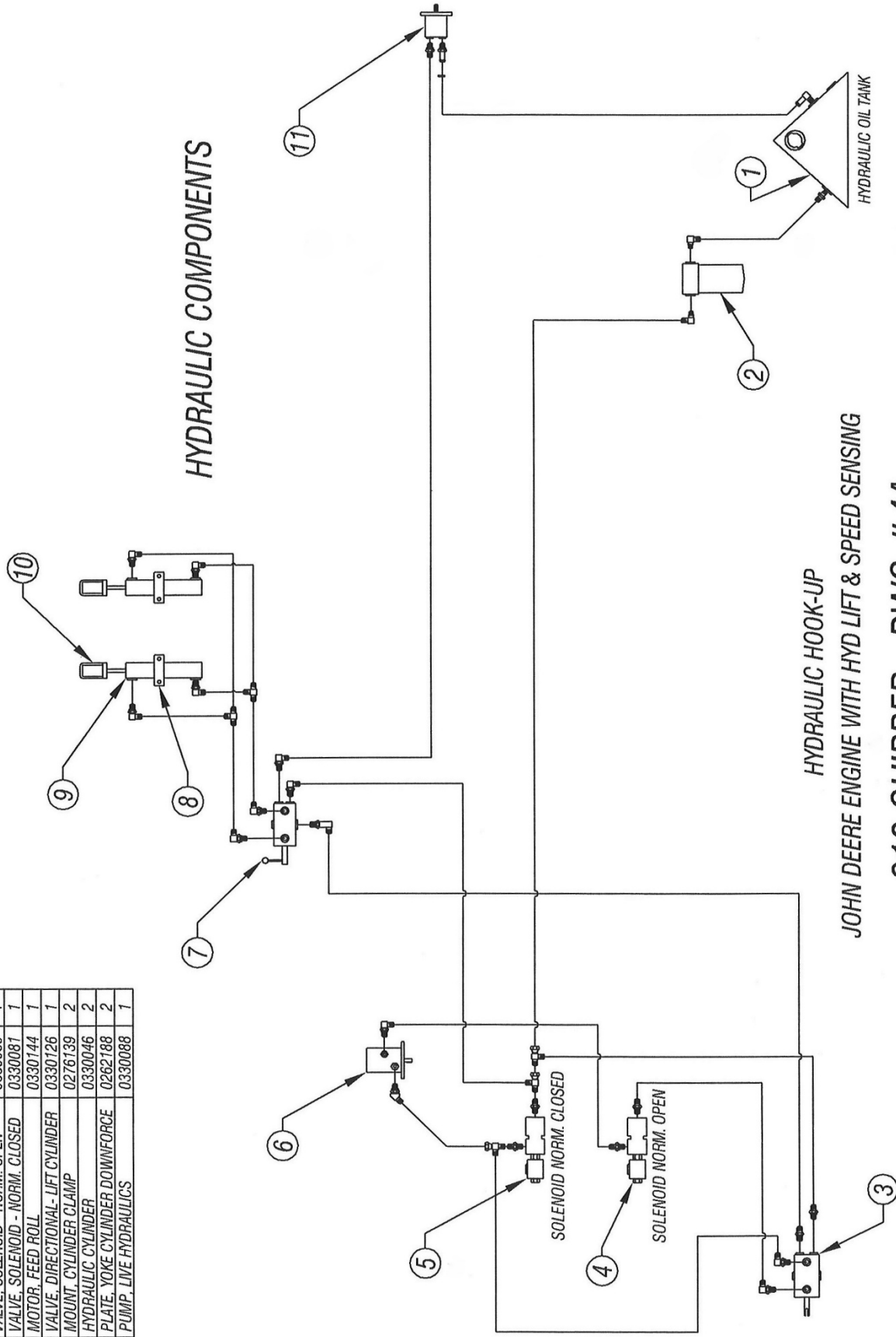

HYDRAULIC HOOK-UP
JOHN DEERE ENGINE WITH HYD LIFT & SPEED SENSING

813 CHIPPER - DWG #4A

ITEM	PART DESCRIPTION	PART#	QTY	ITEM	PART DESCRIPTION	PART#	QTY	ITEM	PART DESCRIPTION	PART#	QTY
1	CONNECTOR, 1/2 FL x 5/8 O-RING	0317027	1	7	CONNECTOR, 1/2 FL x 1/2 O-RING	0317030	2	13	90° ELBOW, 1/2 FL x 5/8 O-RING	0317008	3
2	ADAPTER, 1" TUBE x 3/4 O-RING	0317129	1	8	90° ELBOW, 1/2 FL x 3/8 O-RING	0317064	2	14	90° ELBOW, 1/2 FL x 5/8 O-RING	0317250	1
3	90° ADAPTER, 1" TUBE x 1" MPT	0317081	1	9	CONNECT., 1/2 FL x 3/8 O-RING	0317066	2	15	90° ELBOW, 3/8 FL x 1/2 O-RING	0317044	2
4	CONNECTOR, 5/8 FL x 3/4 MPT	0317262	1	10	SWIVEL TEE RUN, 1/2 x 1/2 x 1/2	0317118	3	16	TEE, 3/8 FLARE x 3/8 FL x 3/8 FL	0317119	2
5	90° ELBOW, 5/8 FL x 3/4 O-RING	0317214	1	11	SWIVEL ELBOW, 1/2 FL x 1/2 NUT	0317055	2	17	90° ELBOW, 3/8 FLARE x 1/4 MPT	0317046	4
6	90° ELBOW, 1/2 FL x 3/4 O-RING	0317079	1	12	45° ELBOW, 1/2 FL x 5/8 O-RING	0317247	1	18	HOSE CLAMP	0310031	2

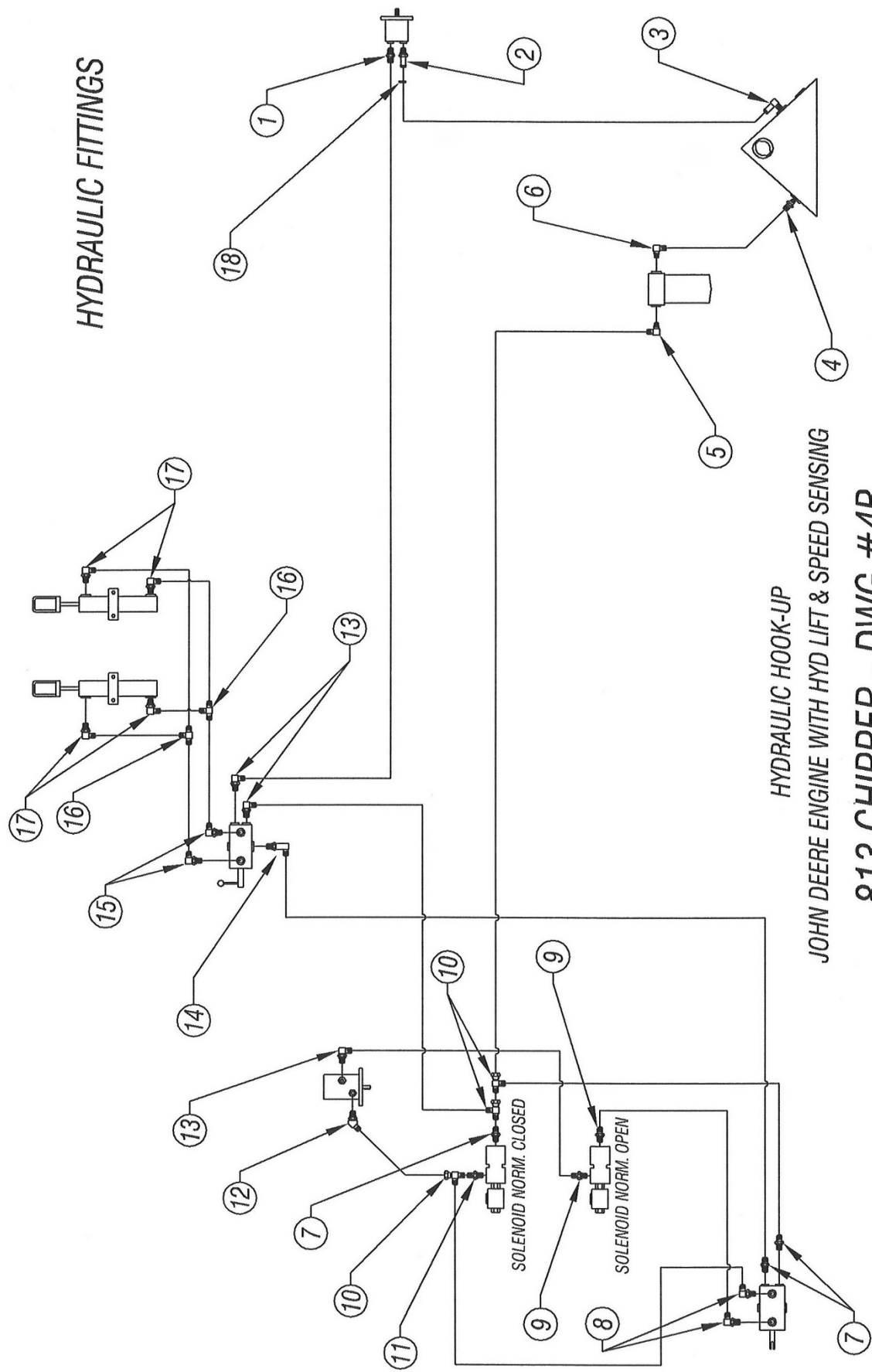

ITEM	PART DESCRIPTION	PART #	QTY	ITEM	PART DESCRIPTION	PART #	QTY
1	L.VALVE TO PUMP, 1/2 ID x 150"	0327118	1	7	SOL.N/O TO R.VALVE, 1/2 ID x 18"	0327076	1
2	PUMP TO TANK, 1" ID x FT	BULK	1	8	R.VAL TO SOL.N/O, 1/2 ID x 22"	0327099	1
3	FILTER TO TANK, 5/8 ID x 24"	0327373	1	9	SOL.N/O TO MOTOR, 1/2 ID x 64"	0327145	1
4	SOL.N/O TO FILTER, 1/2 ID x 20"	0327142	1	10	SOL.N/O TO MOTOR, 1/2 ID x 66"	0327144	1
5	L.VAL TO R.VAL., 1/2 ID x 60"	0327084	1	11	SOL.N/O TO L.VAL., 1/2 ID x 58"	0327141	1
6	SOL.N/O TO R.VALVE, 1/2 ID x 20"	0327090	1	12	L.VAL. TO T-FITTING, 3/8 ID x 34"	0327102	1
				13	L.VAL. TO T-FITTING, 3/8 ID x 28"	0327074	1
				14	CYL. TO T-FITTING, 3/8 ID x 34"	0327101	1
				15	CYL. TO T-FITTING, 3/8 ID x 38"	0327107	1
				16	CYL. TO T-FITTING, 3/8 ID x 77"	0327103	2

HYDRAULIC HOSES

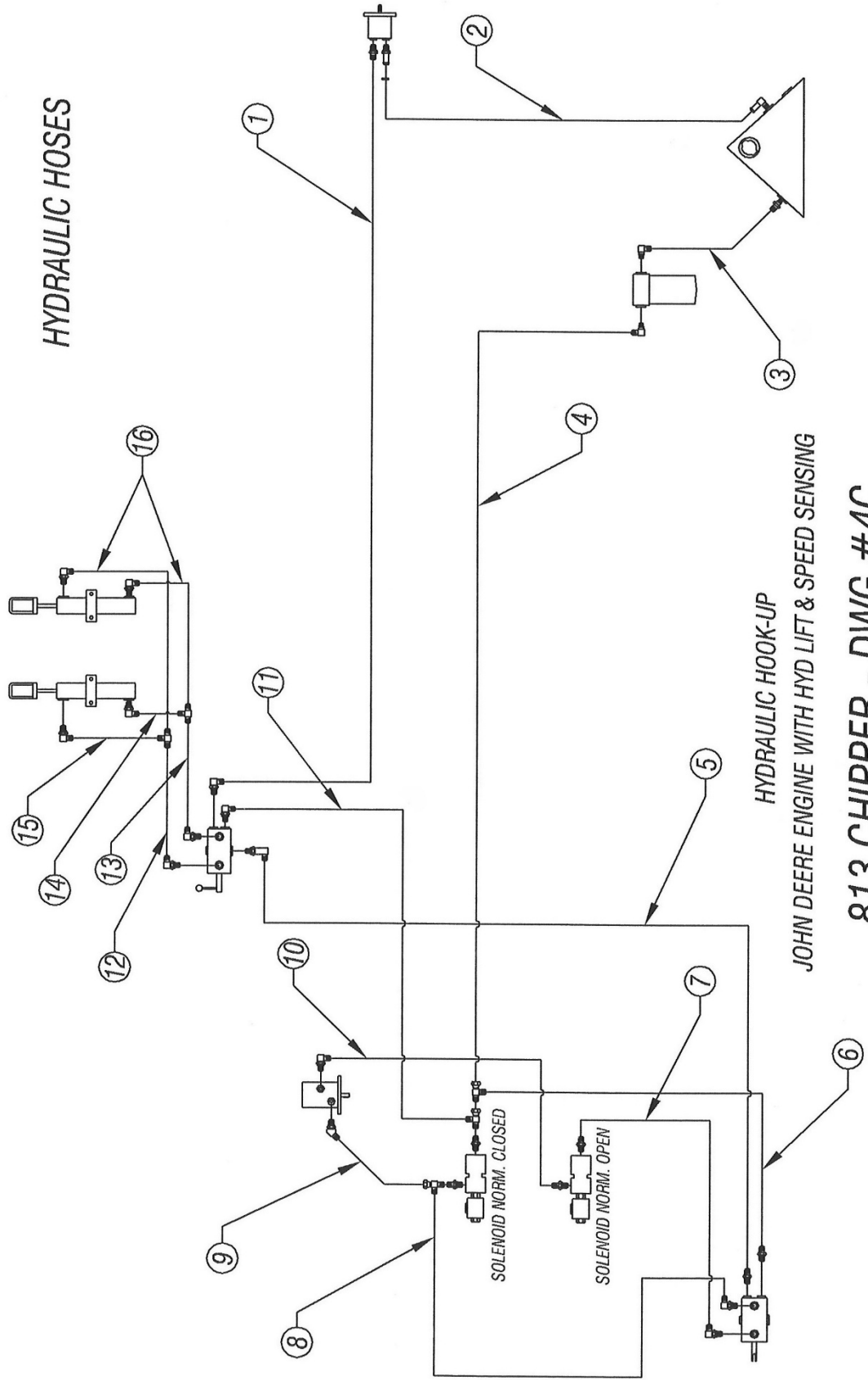

HYDRAULIC HOOK-UP
JOHN DEERE ENGINE WITH HYD LIFT & SPEED SENSING

813 CHIPPER - DWG #4C

HYDRAULIC COMPONENTS

ITEM	PART DESCRIPTION	PART#	QTY
1	HYD CYLINDER	0330046	2
2	PLT. YOKE CYL DOWNFORCE	0262188	2
3	MOUNT. CYL CLAMP	0276139	2
4	MOTOR. FEED ROLL	0330144	1
5	PUMP. LIVE HYD	0330168	1
6	HYD OIL TANK	0252025	1
7	OIL FILTER. HOUSING	0318022	1
8	VALVE. DIRECTIONAL- FD ROLL	0330162	1
9	VALVE.SOLENOID-NORM.OPEN	0330080	1
10	VALVE.SOLENOID-NORM.CLD	0330081	1
11	VALVE. DIRECTIONAL- WINCH	0330103	1
12	MOTOR. WINCH	0330143	1
13	VALVE. DIRECTIONAL- LIFT CYL	0330126	1

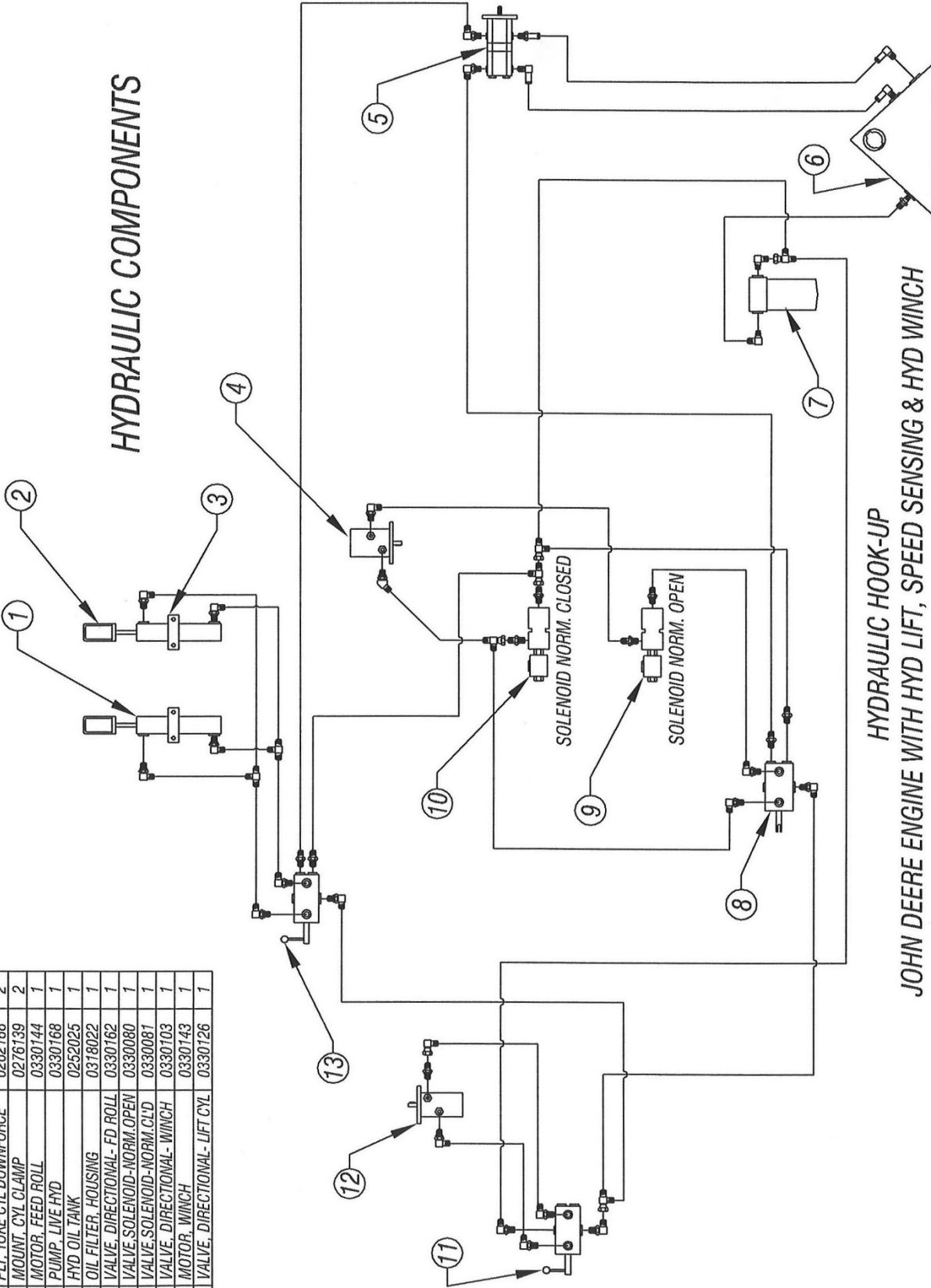

HYDRAULIC HOOK-UP
 HYDRAULIC HOOK-UP WITH HYD LIFT, SPEED SENSING & HYD WINCH
 JOHN DEERE ENGINE - DWG #5A

ITEM	PART DESCRIPTION	PART#	QTY	ITEM	PART DESCRIPTION	PART#	QTY	ITEM	PART DESCRIPTION	PART#	QTY
1	CONNECTOR, 1/2 FL x 5/8 O-RING	0317027	2	11	90° ELBOW, 1/2 FL x 1/2 O-RING	0317007	1	19	90° ELBOW, 3/8 FL x 3/8 O-RING	0317029	2
2	ADAPTER, 1" TUBE x 3/4 O-RING	0317129	2	12	90° ELBOW, 1/2 FL x 3/4 MPT	0317040	2	20	TEE, 3/8 FLARE x 3/8 FL x 3/8 FL	0317119	2
3	90° ADAPTER, 1" TUBE x 1" MPT	0317081	1	13	90° ELBOW, 5/8 FL x 1/2 MPT	0317211	2	21	90° ELBOW, 1/2 FLARE x 1/4 MPT	0317046	4
4	90° ADAPTER, 1" TUBE x 3/4" MPT	0317168	1	14	90° ELBOW, 5/8 FL x 5/8 O-RING	0317276	1	22	45° ELBOW, 1/2 FL x 5/8 O-RING	0317247	1
5	CONNECTOR, 5/8 FL x 3/4 MPT	0317262	1	15	CONNECT., 5/8 FL x 5/8 O-RING	0317277	1	23	90° ELBOW, 1/2 FL x 3/8 O-RING	0317008	1
6	SWIVEL TEE RUN, 1/2 x 1/2 x 1/2	0317118	5	16	SWIVEL ELBOW, 5/8 FL x 5/8 MPT	0317233	1	24	CONNECT., 1/2 FL x 3/8 O-RING	0317066	2
7	90° ELBOW, 1/2 FL x 3/4 O-RING	0317079	1	17	90° ELBOW, 1/2 FL x 1/2 O-RING	0317007	1				
8	90° ELBOW, 5/8 FL x 3/4 O-RING	0317214	1	18	CONNECT., 1/2 FL x 1/2 O-RING	0317030	2				
9	CONNECTOR, 1/2 FL x 1/2 O-RING	0317030	4	19							
10	90° ELBOW, 1/2 FL x 3/8 O-RING	0317064	2	20							

HYDRAULIC FITTINGS

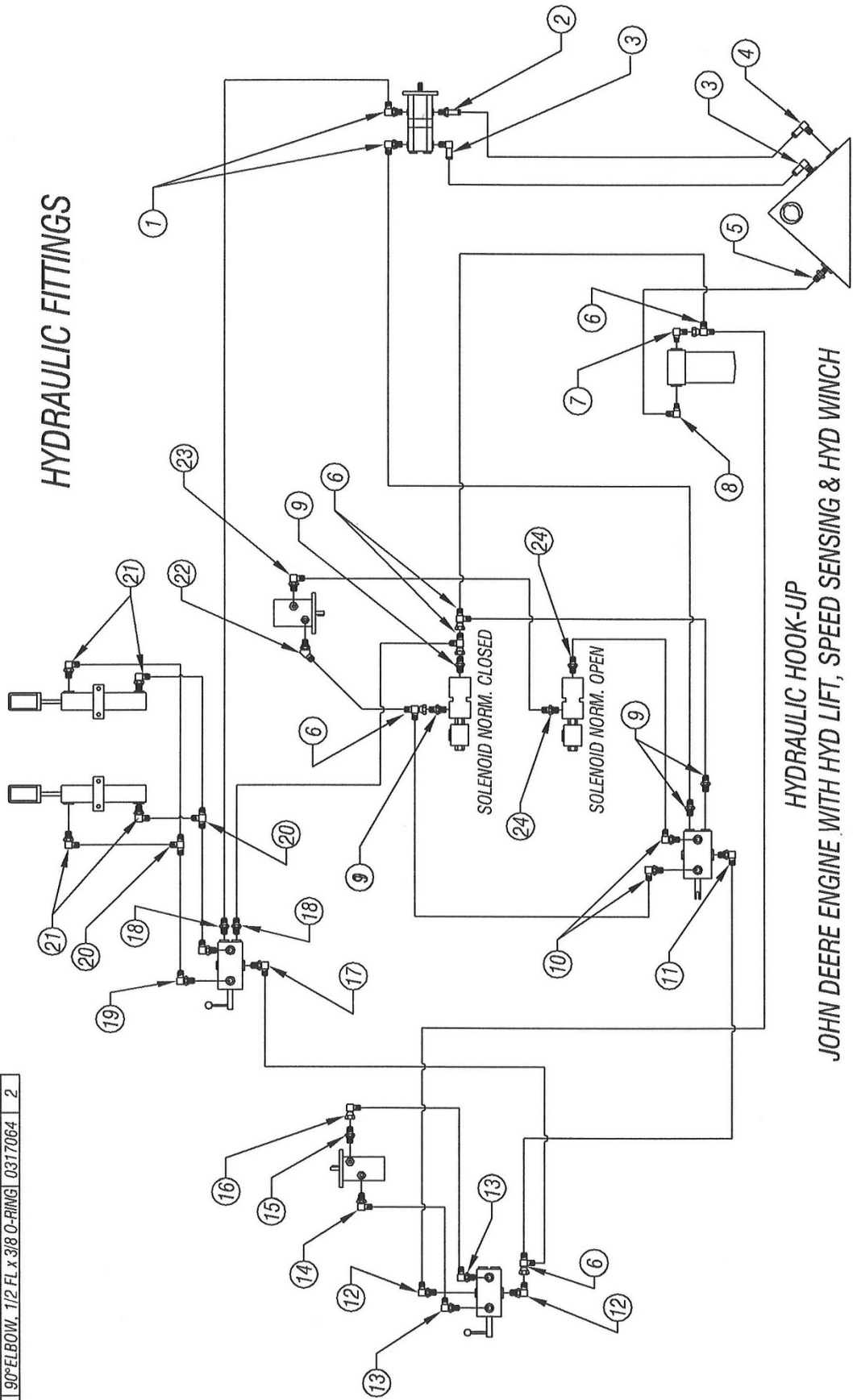

HYDRAULIC HOOK-UP
 JOHN DEERE ENGINE WITH HYD LIFT, SPEED SENSING & HYD WINCH
 813 CHIPPER - DWG #5B

ITEM	PART DESCRIPTION	QTY	PART #	ITEM	PART DESCRIPTION	QTY	PART #	ITEM	PART DESCRIPTION	QTY	PART #
1	R. VALVE TO PUMP, 1/2 ID x 100"	1	0327369	10	W. VAL. TO MOTOR, 1/2 ID x 22"	1	0327372	17	CYL. TO T-FITTING, 3/8 ID x 34"	1	0327101
2	L. VAL. TO AX. PUMP, 1/2 ID x 170"	1	0327370	11	MOTOR TO W. VAL., 5/8 ID x 20"	1	0327353	18	CYL. TO T-FITTING, 3/8 ID x 77"	1	0327103
3	R. VAL. TO SOL. NIC, 1/2 ID x 22"	1	0327099	12	SOL. NIC TO L. VAL, 1/2 ID x 58"	1	0327141	19	SOL. NIC TO FILTER, 1/2 ID x 20"	1	0327142
4	SOL. NIC TO MOTOR, 1/2 ID x 64"	1	0327145	13	L. VAL. TO T-FITTING, 3/8 ID x 34"	1	0327102	20	FILTER TO TANK, 5/8 ID x 24"	1	0327373
5	SOL. NIC TO MOTOR, 1/2 ID x 65"	1	0327144	14	CYL. TO T-FITTING, 3/8 ID x 42"	1	0327376	21	FILTER TO W. VAL., 1/2 ID x 83"	1	0327374
6	SOL. NIC TO R. VALVE, 1/2 ID x 18"	1	0327076	15	CYL. TO T-FITTING, 3/8 ID x 77"	1	0327103	22	AUX. PUMP TO TANK, 1" ID x FIT	1	BULK
7	SOL. NIC TO R. VALVE, 1/2 ID x 20"	1	0327090	16	L. VAL. TO T-FITTING, 3/8 ID x 28"	1	0327074	23	LIFE PUMP TO TANK, 1" ID x FIT	1	BULK
8	R. VALVE TO W. VAL., 1/2 ID x 61"	1	0327377								
9	R. VALVE TO L. VAL., 1/2 ID x 18"	1	0327078								

HYDRAULIC HOSES

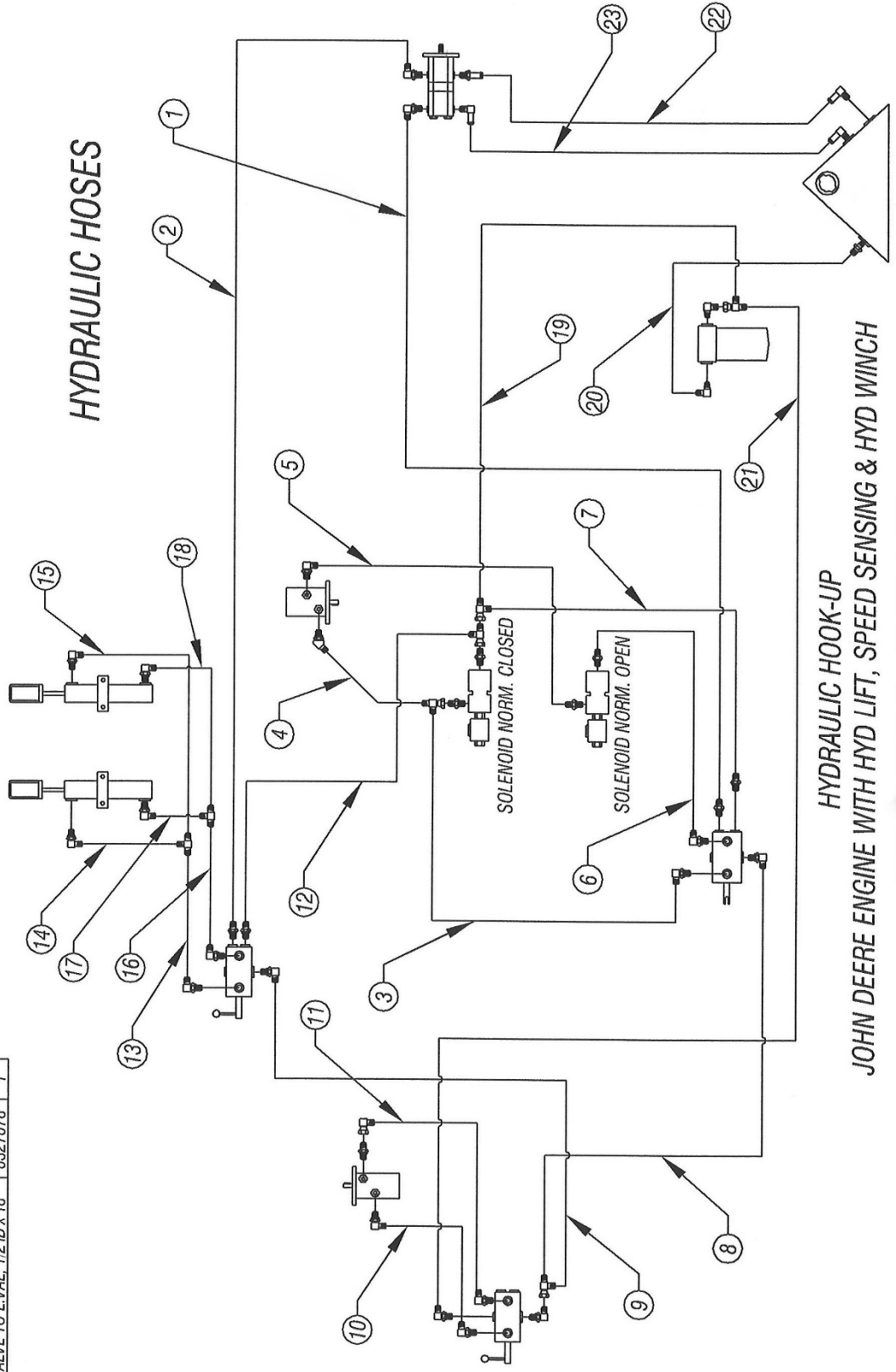

HYDRAULIC HOOK-UP
 JOHN DEERE ENGINE WITH HYD LIFT, SPEED SENSING & HYD WINCH
 813 CHIPPER - DWG #5C

Below is a quick reference chart for various “Flat Head Cap Screws” and the torque recommendations.

VALUES ARE STATED IN FOOT POUNDS

BOLT SIZE	Thds Per Inch	SAE Grade 5	SAE Grade 8
1/4	20	10	14
	28	---	---
5/16	18	19	29
	24	---	---
3/8	16	33	47
	24	---	---
7/16	14	54	78
	20	---	---
1/2	13	78	119
	20	---	---
9/16	12	114	169
	18	---	---
5/8	11	154	230
	11	---	---
3/4	10	257	380
	10	---	---
7/8	9	382	600
	9	---	---
1	8	587	700
	8	---	---

Drive Belt Tension Measurement by Deflection

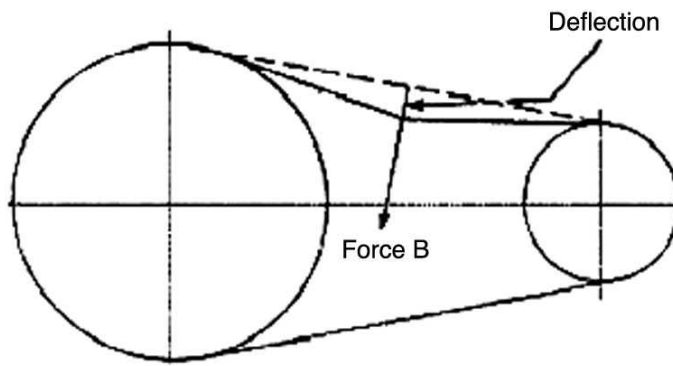

Deflection should be 3/8" when 8-12 lbs. push is applied at "B"

