

Salsco, INC.

LEADER BY DESIGN

OPERATORS AND PARTS MANUAL MODELS 730 & 765 TRUCKLOADER VACS

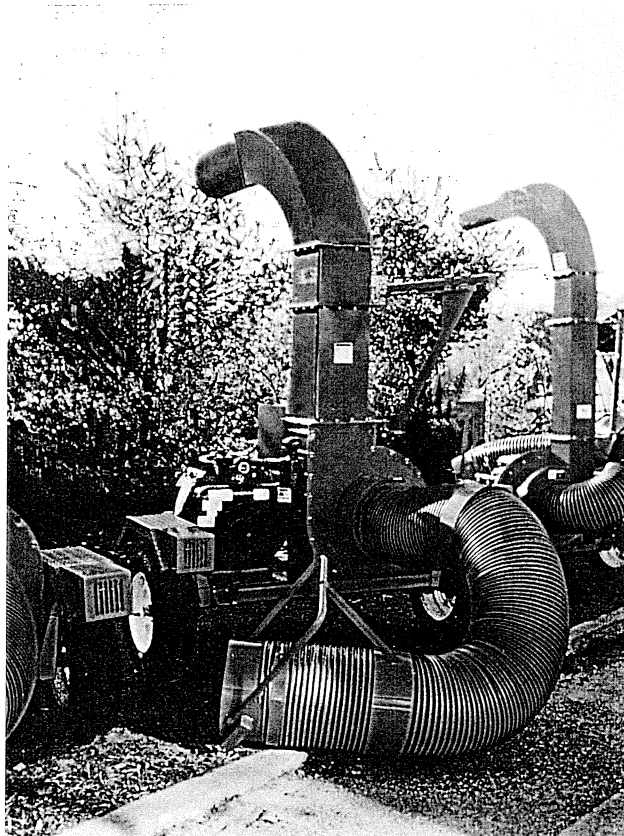

SALSCO, INC.

105 School House Road, Cheshire, CT 06410
203/271-1682, 203/271-2596 (Fax), 1/800/872-5726
salscoinc@AOL.com *www.salsco.com*

TABLE OF CONTENTS
MODEL (S) 730/765 TRUCKLOADER VACS

STATEMENT OF FACT Page 2

SPECIFICATIONS & FEATURESPage 3

MACHINE REGISTRATIONPage 4

SAFETY & OPERATING INSTRUCTIONSPage 5

COPIES OF DECALSPage 6

SERVICE & MAINTENANCE INSTRUCTIONSPage 6

PARTS DIAGRAMSPages 7 – 10

TORQUEPage 11 - 12

WARRANTY POLICY/PROCEDUREPage 13

COPIES OF WARRANTY CLAIM & DEALER DELIVERY REPORTPage 14

SERVICE SCHEDULE LOGPage 15

10/01
SALSCO, INC.
105 School House Rd., Cheshire, CT 06410
800-872-5726, 203-271-1682, 203-271-2596(Fax)
salscoinc@AOL.com, www.salsco.com

STATEMENT OF FACT

You have just purchased the highest quality, most dependable, Truckloader Leaf Vacuum, on the market today. This unit has the ability to meet exact standards and perform for years with minimum downtime. HOWEVER, it cannot read nor will it understand this manual no matter how long you leave it on top of the machine. It is your responsibility to read and understand this manual. It is also your responsibility to be certain this information is passed along to anyone who is expected to operate this equipment. Should you choose not to read, understand and pass along the information provided you, please expect equipment failure and possible injuries to persons around this equipment.

For the safety of the operator, it is **imperative** that this manual is carefully read and understood.

Having read this manual, it is your responsibility to be sure that all new operators read and understand this manual, especially all cautions stated.

As a manufacturer of equipment, we have a responsibility to design a safe piece of equipment. NOTE: The important safeguards and instructions in this manual are not meant to cover all possible conditions and situations that may occur. It must be understood that common sense, caution, and care are factors, which cannot be built into any product. These factors must be supplied by the person(s) caring for and operating this equipment.

HOWEVER, ONLY YOU CAN PREVENT ACCIDENTS!!

SPECIFICATIONS & FEATURES

MODEL: 730 (30hp Wisconsin, gas) or 765 (65hp Wisconsin, gas)

VACUUM HOSE: Model 730 has a 10' x 16" diameter hose
Model 765 has a 10' x 18" diameter hose

TAPER LOCK PULLEYS: All pulleys are taper lock and NOT set screw type.

BELT: Triple "B" section single back belt. Durable, cost effective way to drive the remote mounted impeller.

BATTERY: 12 volt, 350 CCA, automotive type.

HOSE HANDLE: Large rectangular handle with stabilizer bracket and hose ring.

HOSE HANGER ASSEMBLY: Swivels, height of hose and length of vacuum position adjustable.

IMPELLER: 26" diameter paddle type, machined and balanced; welded to a 2" main shaft for easy replacement; 4 blades, ½" thick x 11" x 12".

EXHAUST: 12" round tube exhaust.

FUEL TANK: Extra large 16 gallon steel fuel tank.

REPLACEABLE WEAR WRAP: Easy and inexpensive to replace.

SHREDDER WIRES: Replaceable wires will shred material up to 30%, depending on material being vacuumed.

AXLE: T-Flex torsion axle allows for smooth towing, even at highway speeds.

TIRES: F78-14ST Tubeless. 6 Ply x 26".

TRAILER FRAME: 2" x 3" x ¼" rectangular steel tubing; continuous welds and gusseted for extra strength.

JACK: Bulldog top wind swivel.

COUPLER: 2" Ball, standard size, with safety chain.

FENDERS: Heavy duty diamond plate steel fenders, gusseted, with tail light protectors.

TONGUE: Bolt on and gusseted, with bracket for holding hose while being transported.

LIGHT PACKAGE: D.O.T. approved; turn and stop lights, mounted inside light protectors, wired & ready to plug in.

PAINT: Powder coated baked enamel polyester finish; keeps the machine looking good for years to come; resists Ultraviolet light.

LENGTH: 110" * HEIGHT TO TOP OF EXHAUST 111" * WIDTH 77"

WEIGHT: Model 730 – Approximately 2,100-lb. * Model 765 – Approximately 2,500-lb.

OPTIONS:

- Available Skid Mounted or Trailered
- Choice of Coupler
- Extra length of Hose with Coupler
- Custom Color Powder Coat Paint

MACHINE REGISTRATION

MANUFACTURED BY:

SALSCO, INC.
105 School House Rd., Cheshire, CT 06410
800-872-5726, 203-271-1682, 203-271-2596 (Fax)
sales@salsco.com www.salsco.com

THIS MANUAL COVERS MODEL (s): 730 & 765 TRUCKLOADER VACUUMS:

This company reserves the right to discontinue, add improvements to, or change the design of any model or product at any time without obligation to improve existing machines, either by changing the design or adding new parts.

It has been and will continue to be the policy of SALSCO to update existing machines at its own discretion. Whenever possible, new designs will be made in such a way that they can be "Retro Fit" if so desired.

Record in the space provided below the model and serial number of this unit. Please retain these numbers for future reference.

No parts orders will be accepted **WITHOUT MODEL NUMBERS OR PART NUMBERS**. All part numbers are listed in this manual.

Serial Number

Model Number

NOTE: Be sure to complete your warranty card. This will insure immediate processing of any warranty claims.

READ AND UNDERSTAND THIS MANUAL BEFORE STARTING THE MACHINE

SAFETY INSTRUCTIONS

BEFORE YOU START THIS MACHINE:

1. **READ** and **UNDERSTAND** this owner's manual.
2. **DO NOT** run machine without guards and other safety covers in place.
3. **NEVER** leave machine running while unattended.
4. **NEVER** reach under or into machine for any reason while machine is running as it can cause serious injury.
5. **ALWAYS** remove spark plug wire, **MAKE SURE** engine is off, throttle is in stop position, and shut gas off when working on or checking inside machine.
6. **NEVER** clean inlet tube or outlet tubes while engine is running.
7. **EYE PROTECTION** should **ALWAYS BE WORN** when running machine.
8. **BE SURE** air intake on engine is clear of leaves and debris.
9. **DO NOT** remove caution decals.
10. Safety decals should be replaced immediately after repainting or when they become illegible. Safety is a prime concern at Salsco and the safety decals on your machine are a highly visible and constant reminder to all operators. Replacement safety decals may be obtained from your local dealer or by calling Salsco at (203) 271-1682 or 1-800-872-5726.

OPERATING INSTRUCTIONS

1. **READ MANUAL THOROUGHLY!**
2. **BE SURE** intake hose is connected to blower housing. **NEVER RUN UNIT WITH INTAKE HOSE DISCONNECTED.**
3. Place inlet hose on ground near pile of debris.
4. Before starting motor, **make sure everyone is clear of machine and discharge chute is pointing in the correct position.** Start the motor, and let it idle until engine warms up (see engine manual provided)
5. Bring up to full R.P.M. slowly, **checking for vibration.**
6. You can either move the inlet hose by hand or blow leaves to the inlet tube. It will pick up most of the pile by itself.

CAUTION: BE CAREFUL NOT TO PICK UP ROCKS, BOTTLES, ETC. AS THIS COULD RESULT IN DAMAGE TO THE UNIT AND INJURY TO THE OPERATOR.

SAFETY DECALS

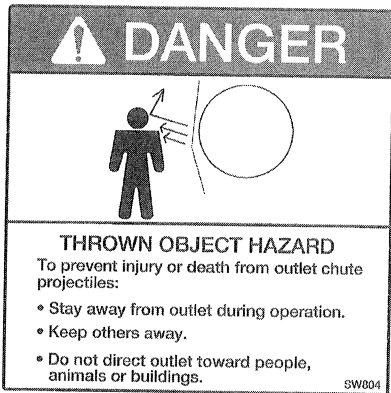

Warning
Moving Parts Hazard

To prevent serious injury or death from moving parts:
Close and secure guards and shield before starting engine.
Keep hands, feet, hair, and clothing away from moving parts.
Stop engine to adjust or service.
Do not stand or climb on machine while operating.

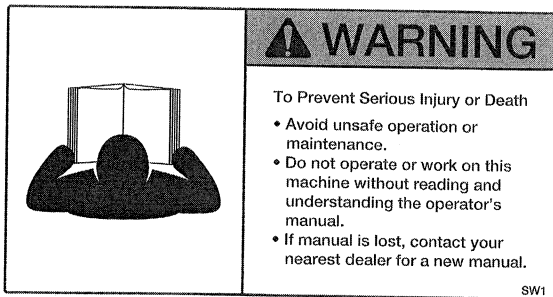

Danger

To prevent serious injury or death, operate only with vacuum tube securely installed.

ADJUSTING CLAMP TO FIT TAILGATE

1. Remove two bolts on each arm.
2. Adjust for approximate length on both sides to fit tailgate.
3. Reinsert two bolts on each arm.
4. Press each clamp lever into lowest position.
5. Lock each lever by tightening the knob.
6. Lower the safety lock on each side.
7. Tighten knob to secure lock in place.

SERVICE & MAINTENANCE SCHEDULE

Check Engine Oil (See Engine Manual)	Daily
Check Vibrations	Daily
Check for Torn or Damaged Hose	Daily
Visually Check for Loose Bolts or Damage	Daily
Clean Machine	Daily
Check Tires (Trailer Units)	Daily
Check Battery for Water & Electrical Connections	Weekly

IMPELLER ASSEMBLY
730/765 TRUCKLOADER VAC

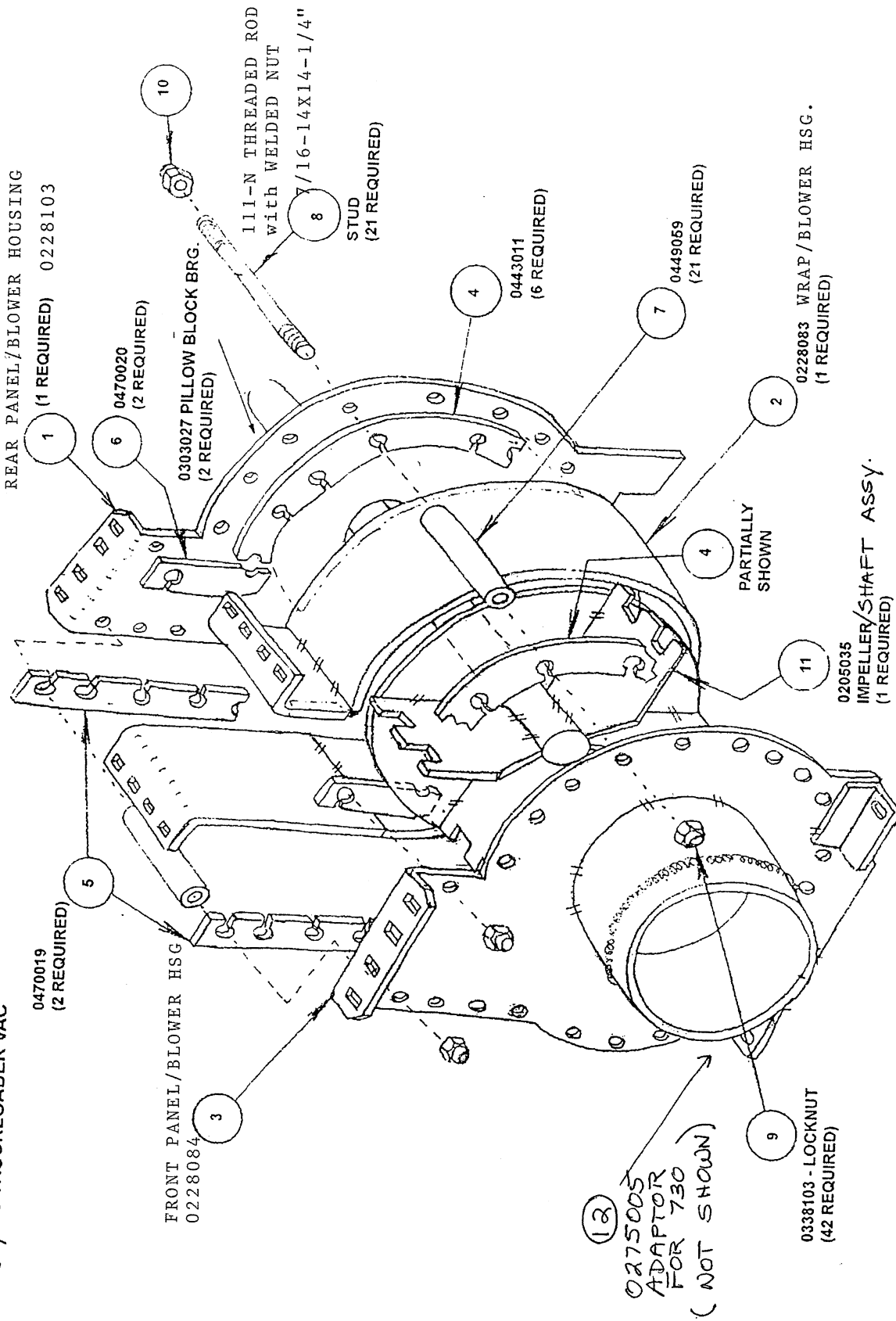

SHREDDER SPRING ASSEMBLY

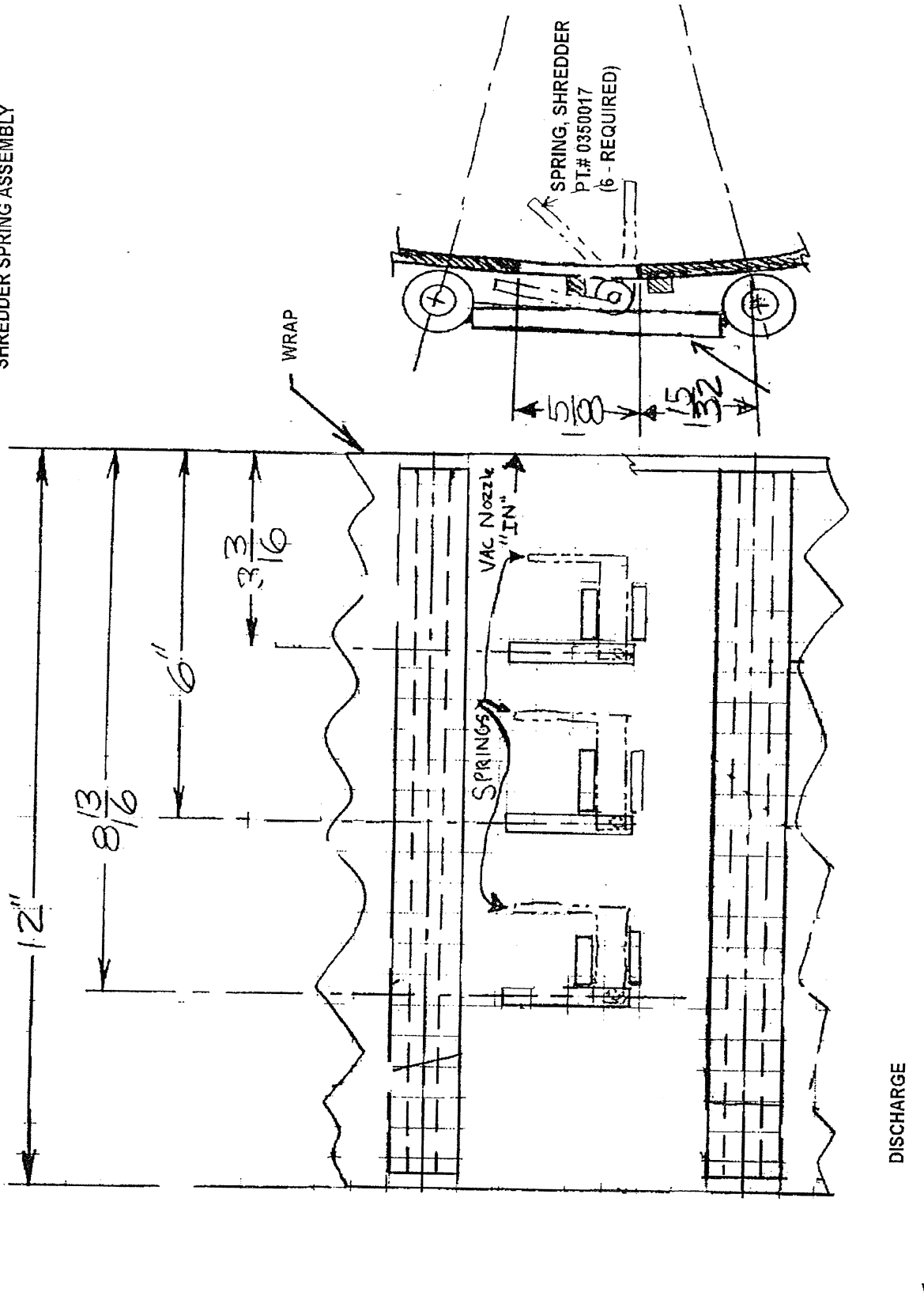

FRAME & TRAILER ASSEMBLY

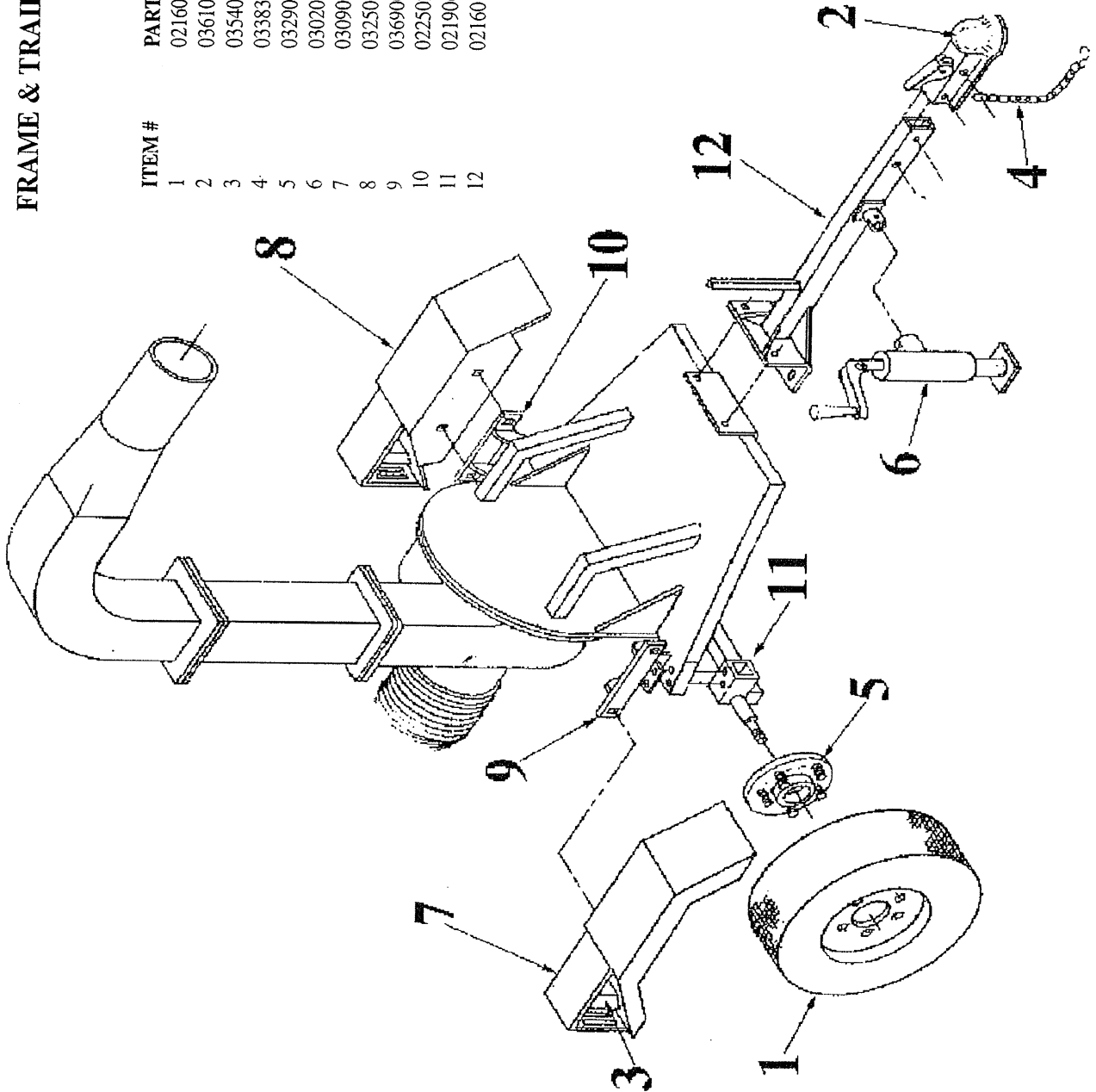

ITEM #	PART #	DESCRIPTION	QTY.
1	0216012	Fender, Right	1
2	0361006	Tail Light Kit	2
3	0354025	Wheel & Rim	2
4	0338306	Lug Nut	10
5	0329002	Hub Assembly	2
6	0302024	Axle	1
7	0309018	Safety Chain	1
8	0325007	Coupler, Tongue	1
9	0369001	Jack Swivel	1
10	0225022	Tongue Assembly	1
11	0219067	Town Frame	1
12	0216011	Fender, Left	1

Bolt Torque Info

Torque and Clamp loads for grade 5 and 8 fasteners.

Size	Grade 5			Grade 8		
	Clamps (lbs)	Torque (ft-lbs)		Clamps (lbs)	Torque (ft-lbs)	
		dry	oiled		dry	oiled
¼-20	2000	8	6	2850	12	9
¼-28	2300	10	7.5	3250	14	10
5/16-18	2250	17	13	4700	25	18
5/16-24	3700	19	14	5200	25	20
3/8-16	4950	30	23	7000	45	35
3/8-24	5600	35	25	7900	50	35
7/16-14	6800	50	35	9550	70	55
7/16-20	7600	55	40	10650	80	60
½-13	9000	75	55	12750	110	80
½-20	10250	90	65	14375	120	90
9/16-12	11600	110	80	16375	150	110
9/16-18	13000	120	90	18250	170	130
5/8-11	14400	150	110	20350	220	170
5/8-18	16375	180	130	23000	240	180
¾-10	21300	260	200	30100	380	280
¾-16	23800	300	220	33500	420	320

Drive Belt Tension Measurement by Deflection

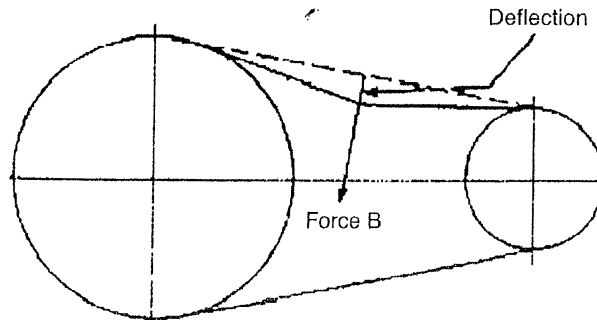

Deflection should be 3/8" when
8-12 lbs. push is applied at "B"

O:\Manuals\bolt torque info sheet.doc
Revised 8/04

Suggested Tightening Torques For **Alloy** 1960 Inch Series Socket Head Cap Screws

NOMINAL SIZE	BASIC SCREW DIAMETER INCHES	TORQUE TO TIGHTEN SCREWS TO YIELD (In-lb)		TIGHTENING TORQUE* (In-lb)	
		UNRC	UNRF	UNRC	UNRF
0	0.0600	—	3.5	—	2.6
1	0.0730	6	6.5	4.5	4.8
2	0.0860	10	11	7.5	8
3	0.0990	15	16	11	12
4	0.1120	22	24	16	18
5	0.1250	32	33	24	24
6	0.1380	40	45	30	34
8	0.1640	74	78	55	58
10	0.1900	105	120	79	90
		(ft-lb)		(ft-lb)	
1/4	0.2500	22	25	17	19
5/16	0.3125	46	51	35	38
3/8	0.3750	83	93	62	70
7/16	0.4375	132	146	100	109
1/2	0.5000	203	230	150	172
5/8	0.6250	380	430	283	317
3/4	0.7500	667	750	500	562
7/8	0.8750	917	1020	688	767
1	1.0000	1390	1520	1040	1080
1-1/4	1.2500	2780	3080	2080	2310
1-1/2	1.5000	4850	5450	3625	4080

Nominal Sizes	Tensile Strength P.S.I. Min.	Yield Strength P.S.I. Min.	Elongation* In 2 Inches Per Cent Min.	Reduction of Area* Per Cent Min.	Minimum Hardness Rockwell C
0 to 1/2	180,000	162,000	12	35	39
Over 1/2	170,000	153,000	14	40	38

* Listed tightening torques are 75 percent of the torque to yield based on ASTM574. Specification listing tensile strength of 180,000 PSI for screw size 0.500 and smaller and 170,000 PSI for screw size 0.625 and larger. Values based on plated and non-lubricated fasteners.

Tightening torques are only recommended for proper applications. Refer to your engineering stats.

Suggested Tightening Torques For Other **Alloy** Socket Screw Products (INCH-POUND)

Nom. size	Basic Screw Diameter	Button Head Flat Head Hex Key Size	Flat Head		Button Head		Shoulder Screw		Low Head	
			Tightening Torque	Tightening Torque	Tightening Torque	Tightening Torque	Nominal Size	Hex Key Size	Tightening Torque	Tightening Torque
0	.060	.035	—	1.5	—	1.5	—	—	—	—
1	.073	.050	2.5	2.5	2.5	2.5	—	—	—	—
2	.086	.050	4.5	4.5	4.5	4.5	—	—	—	—
3	.099	1/16	7	7	7	7	—	—	—	—
4	.112	1/16	8	8	8	9	4	.050	—	5.0
5	.125	5/64	12	13	12	12	5	.062	—	9.5
6	.138	5/64	15	17	16	16	6	.062	—	9.5
8	.164	3/32	30	31	30	30	8	5/64	—	19.4
10	.190	1/8	40	45	40	45	10	3/32	—	33.5
1/4	.250	5/32	100	110	100	110	1/4	1/8	50	77.9
5/16	.312	3/16	200	220	200	220	5/16	5/32	125	156.0
3/8	.375	7/32	350	400	350	400	3/8	3/16	285	273.0
7/16	.437	1/4	560	625	—	—	7/16	7/32	—	428.0
1/2	.500	5/16	850	1,000	850	1,000	1/2	1/4	470	615.0
9/16	.562	5/16	1,200	1,360	—	—	—	—	—	—
5/8	.625	3/8	1,700	1,900	1,700	1,800	5/8	5/16	1,150	1,315.0
3/4	.750	1/2	3,000	3,200	—	—	3/4	3/8	2,000	—
7/8	.875	9/16	5,000	5,400	—	—	—	—	—	—
1	1.000	5/8	8,000	7,600	—	—	1	1/2	4,000	—

* Listed tightening torques are 75 percent of the torque to yield based on ASTM574. Specification listing tensile strength of 180,000 PSI for screw size 0.500 and smaller and 170,000 PSI for screw size 0.625 and larger. Values based on plated and non-lubricated fasteners.

Tightening torques are only recommended for proper applications. Refer to your engineering stats.