

- AMS - ACTUATOR MOTOR SWITCH
- BD1 - BRIDGE DIODE 1
- BD2 - BRIDGE DIODE 2
- MCB - MAIN CIRCUIT BREAKER
- CB1 - CIRCUIT BREAKER 1
- CB2 - CIRCUIT BREAKER 2
- CB3 - CIRCUIT BREAKER 3
- CB4 - CIRCUIT BREAKER 4
- CPS - COOLANT PUMP SWITCH
- DSS - DOOR SAFETY SWITCH
- EMS - ELECTROMAGNET SWITCH
- ESS - EMERGENCY STOP SWITCH
- GMS - GRINDING MOTOR SWITCH
- LVR - LOW VOLTAGE RELAY
- MAG - MAGNETIC STARTER
- PX1 - LEFT PROXIMITY SWITCH
- PX2 - RIGHT PROXIMITY SWITCH
- REL - GRINDING MOTOR RELAY
- SCB - SECONDARY CIRCUIT BREAKER
- SSS - SYSTEM START SWITCH
- TDC - TRAVERSE DRIVE CONTROL
- TF1 - TRANSFORMER ASSEMBLY MAGNETS
- TF2 - TRANSFORMER ASSEMBLY ACTUATOR
- TMS - TRAVERSE MOTOR SWITCH
- TSP - TRAVERSE SPEED POT
- UPS - UNINTERUPTABLE POWER SUPPLY

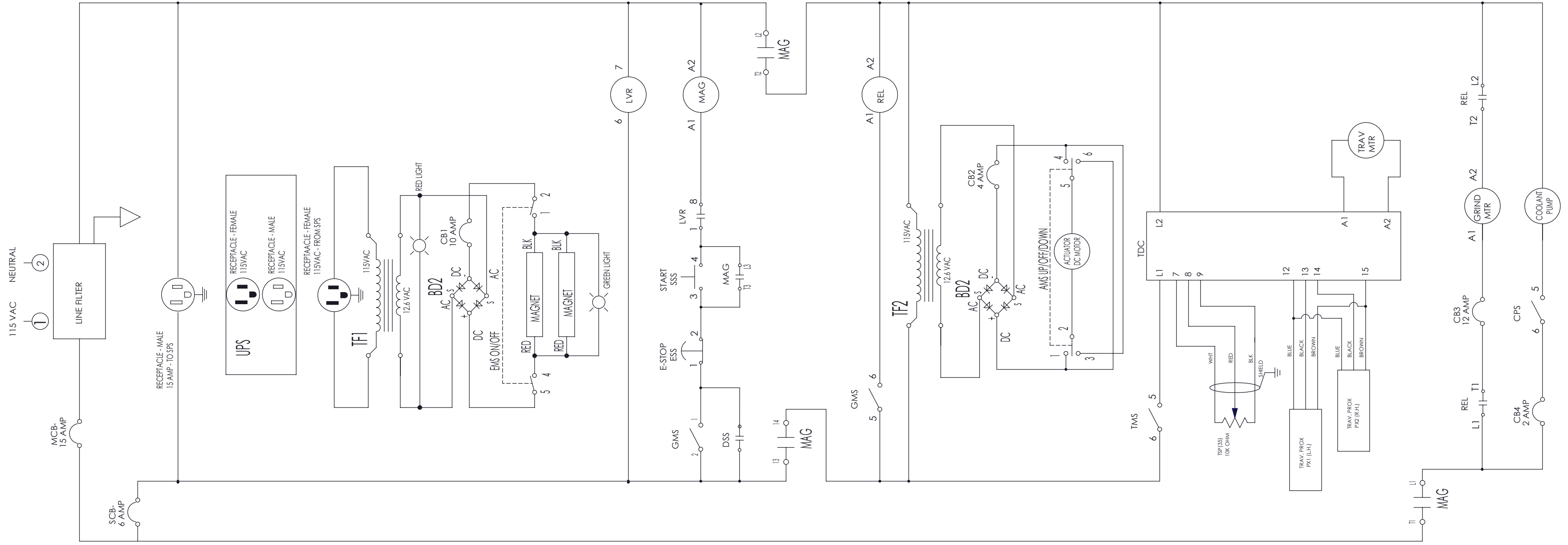

LIMITS IF NOT SPECIFIED		MATERIAL		2	018	THERMISTOR	GAV	9-24-10
.0	±.03	HEAT TREATMENT		1	010	RELEASE FOR PRODUCTION	GAV	5-7-10
.00	±.01	FINISH		REV	ECO	ISSUE AND CHANGE RECORD	BY	DATE
.000	±.005	672 ELECTRICAL SCHEMATIC						
ANGULAR	± 1°							
DIA. TOLERANCE FOR DRILLED HOLES								
0-.125	+0.002-.000							
.126-.500	+0.003-.000							
.501-LARGER	+0.005-.000	DO NOT SCALE		DR: G. VEENENDALL		5-7-10	PART NO.	
SCALE	NONE	SPEC. NO.		FOLEY-UNITED		5-7-10	6723507	
				APPR: G. VEENENDALL		5-7-10		