

6529564 TOUCH SCREEN CONVERSION KIT INSTALLATION INSTRUCTIONS

CONVERTS AN OLDER CIMREX TOUCH SCREEN OR EXTER TOUCH SCREEN

THIS TOUCH SCREEN CONVERSION KIT APPLIES TO 652 ACCU-MASTER AND 632 ACCU-PRO GRINDERS WITH THE ACCUTOUCH CONTROL USING A CIMREX OR EXTER TOUCHSCREEN.

INSTALLATION:

1. Unplug the Grinder from the wall outlet to remove all power to the machine.
2. Remove the 5 screws holding the Control Panel Top to the Control Panel.
3. Disconnect the cable that connects the Touchscreen to the PLC and disconnect all wires to the Control Panel Switches, Buttons and Knobs. (You may want to take a picture to aid in reattaching wires or use the Wiring Diagram from the Service Manual).
4. Lift the Control Panel Top from the Control Panel. The Top is sealed around the edges with clear silicon and may need to be cut to aid in the removal of the Top.
5. Install the new Control Panel Top (6529562) from the Update Kit.
6. Apply the new Decal (6529563) and install the new Touchscreen (6529565) to the Control Panel Top.
7. Transfer each Button, Switch, and Knob from the old Control Panel Top to the new Control Panel Top. There is a new Torque Pot Decal (3706077) to use for machines with the newer Spin Drive Control.
To remove Knobs: Loosen Set Screw and pull off Knob. Remove retaining nut.
To remove Buttons: Use a small, flat blade screwdriver to pry the spring to remove the wire terminal block and then unscrew the retaining nut.
To remove Switches: Push in locking tabs on the ends of the Switch and push Switch through the opening.
8. Install the new cord to the COM1 Port on the Touchscreen and the other end to the PLC port.
9. Install all wires to Buttons, Switches, and Knobs. (Use Wiring Diagram in Service Manual).
10. Install and reseal the Control Panel Top to the Control Panel, using the 5 screws and silicon.
11. Reconnect the power to the machine and turn ON and teste all functions.

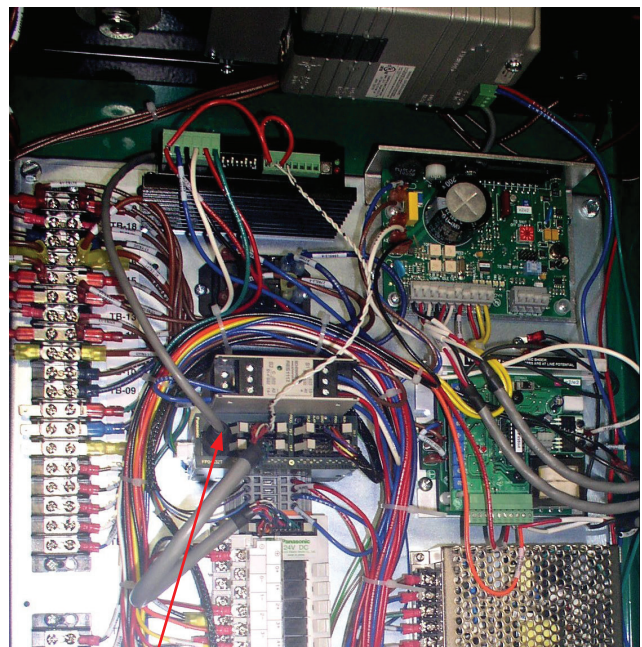
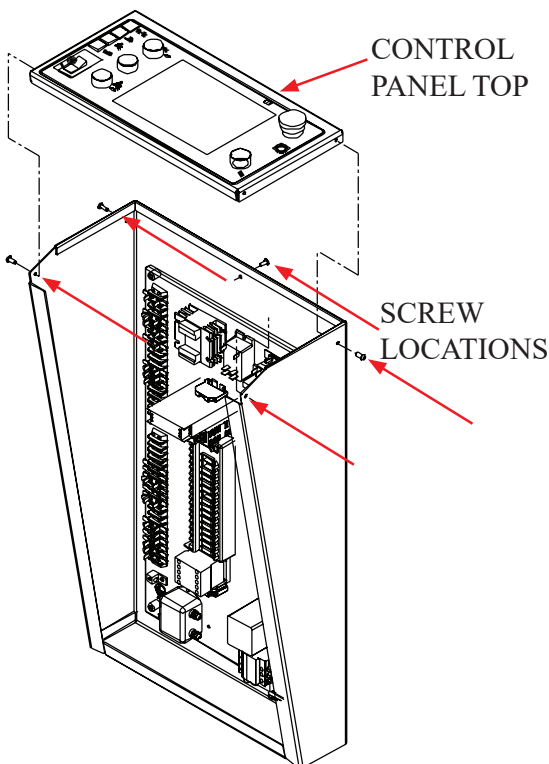

PLC

FIG 1.

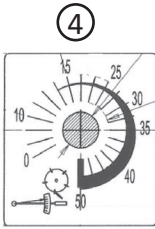

INCLUDE DECAL 3706077.
THESE ARE FOR NEWER MACHINES
WITH THE NEWER SPIN DRIVE CONTROL.

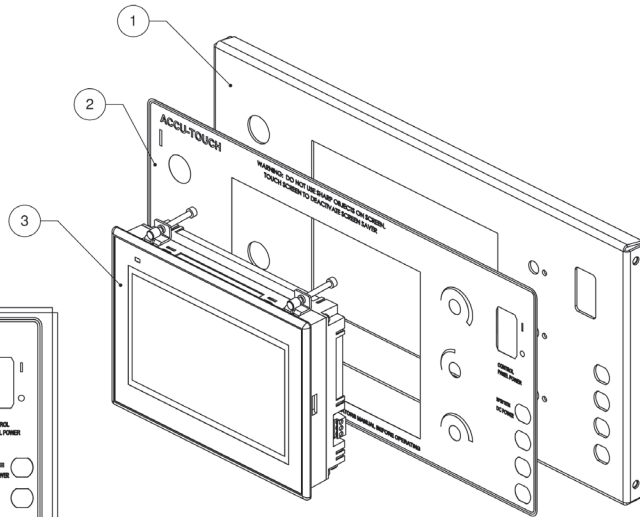
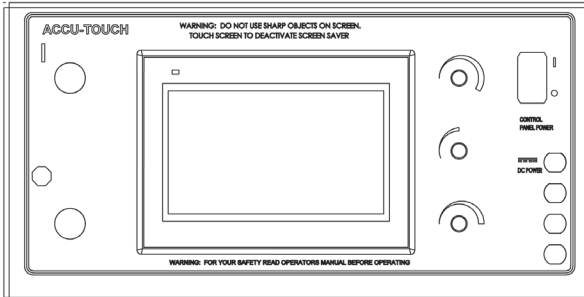

FIG 2.

DRAWING NO.	PART NO.	DESCRIPTION
1.....	6529562	CONTROL PANEL WELDMENT
2.....	6529563	CONTROL PANEL DECAL
3.....	6529565	7" TOUCHSCREEN
4.....	3706077	TORQUE POT DECAL
NOT SHOWN...	6529112	TOUCHSCREEN CABLE ASSEMBLY