

**ACCU-Master
AUTOMATIC
REEL MOWER GRINDER
with ACCU-Touch**

**ASSEMBLY
and
SERVICE
MANUAL**



WARNING

You must thoroughly read and understand this manual before assembling or maintaining the equipment, paying particular attention to the Warning & Safety instructions.

SAFETY INSTRUCTIONS



Safety Awareness Symbols are inserted into this manual to alert you to possible **Safety Hazards**. Whenever you see these symbols, follow their instructions.



The **Warning Symbol** identifies special instructions or procedures which, if not correctly followed, could result in personal injury.

The **Caution Symbol** identifies special instructions or procedures which, if not strictly observed, could result in damage to or destruction of equipment.

1. **KEEP GUARDS IN PLACE** and in working order.
2. **REMOVE WRENCHES AND OTHER TOOLS.**
3. **KEEP WORK AREA CLEAN.**
4. **DON'T USE IN DANGEROUS ENVIRONMENT.**
Don't use Grinder in damp or wet locations. Machine is for indoor use only. Keep work area well lit.
5. **KEEP ALL VISITORS AWAY.** All visitors should be kept a safe distance from work area.
6. **MAKE WORK AREA CHILD-PROOF** with padlocks or master switches.
7. **DON'T FORCE THE GRINDER.** It will do the job better and safer if used as specified in this manual.
8. **USE THE RIGHT TOOL.** Don't force the Grinder or an attachment to do a job for which it was not designed.
9. **WEAR PROPER APPAREL.** Wear no loose clothing, gloves, neckties, or jewelry which may get caught in moving parts. Nonslip footwear is recommended. Wear protective hair covering to contain long hair.
10. **ALWAYS USE SAFETY GLASSES.**
11. **SECURE YOUR WORK.** Make certain that the cutting unit is securely fastened with the clamps provided before operating.
12. **DON'T OVERREACH.** Keep proper footing and balance at all times.
13. **MAINTAIN GRINDER WITH CARE.** Follow instructions in Service Manual for lubrication and preventive maintenance.
14. **DISCONNECT POWER BEFORE SERVICING,** or when changing the grinding wheel.
15. **DO NOT USE SHARP OBJECTS ON THE TOUCH SCREEN.** Do not clean the touch screen with solvents.
16. **USE RECOMMENDED ACCESSORIES.** Consult the manual for recommended accessories. Using improper accessories may cause risk of personal injury.
17. **CHECK DAMAGED PARTS.** A guard or other part that is damaged or will not perform its intended function should be properly repaired or replaced.
18. **KNOW YOUR EQUIPMENT.** Read this manual carefully. Learn its application and limitations as well as specific potential hazards.
19. **KEEP ALL SAFETY DECALS CLEAN AND LEGIBLE.** If safety decals become damaged or illegible for any reason, replace immediately. Refer to replacement parts illustrations in Service Manual for the proper location and part numbers of safety decals.
20. **DO NOT OPERATE THE GRINDER WHEN UNDER THE INFLUENCE OF DRUGS, ALCOHOL, OR MEDICATION.**

SAFETY INSTRUCTIONS



IMPROPER USE OF GRINDING WHEEL MAY CAUSE BREAKAGE AND SERIOUS INJURY.

Grinding is a safe operation if the few basic rules listed below are followed. These rules are based on material contained in the ANSI B7.1 Safety Code for "Use, Care and Protection of Abrasive Wheels". For your safety, we suggest you benefit from the experience of others and carefully follow these rules.

DO

1. **DO** always **HANDLE AND STORE** wheels in a **CAREFUL** manner.
2. **DO VISUALLY INSPECT** all wheels before mounting for possible damage.
3. **DO CHECK MACHINE SPEED** against the established maximum safe operating speed marked on wheel.
4. **DO CHECK MOUNTING FLANGES** for equal and correct diameter.
5. **DO USE MOUNTING BLOTTERS** when supplied with wheels.
6. **DO** be sure **WORK REST** is properly adjusted.
7. **DO** always **USE A SAFETY GUARD COVERING** at least one-half of the grinding wheel.
8. **DO** allow **NEWLY MOUNTED WHEELS** to run at operating speed, with guard in place, for at least one minute before grinding.
9. **DO** always **WEAR SAFETY GLASSES** or some type of eye protection when grinding.

DON'T

1. **DON'T** use a cracked wheel or one that **HAS BEEN DROPPED** or has become damaged.
2. **DON'T FORCE** a wheel onto the machine **OR ALTER** the size of the mounting hole - if wheel won't fit the machine, get one that will.
3. **DON'T** ever **EXCEED MAXIMUM OPERATING SPEED** established for the wheel.
4. **DON'T** use mounting flanges on which the bearing surfaces **ARE NOT CLEAN, FLAT AND FREE OF BURRS**.
5. **DON'T TIGHTEN** the mounting nut excessively.
6. **DON'T** grind on the **SIDE OF THE WHEEL** (see Safety Code B7.2 for exception).
7. **DON'T** start the machine until the **WHEEL GUARD IS IN PLACE**.
8. **DON'T JAM** work into the wheel.
9. **DON'T STAND DIRECTLY IN FRONT** of a grinding wheel whenever a grinder is started.
10. **DON'T FORCE GRINDING** so that motor slows noticeably or work gets hot.



AVOID INHALATION OF DUST generated by grinding and cutting operations. Exposure to dust may cause respiratory ailments. Use approved NIOSH or MSHA respirators, safety glasses or face shields, and protective clothing. Provide adequate ventilation to eliminate dust, or to maintain dust level below the Threshold Limit Value for nuisance dust as classified by OSHA.

This machine is intended for grinding the reel of reel type mower units ONLY. Any use other than this may cause personal injury and void the warranty.



To assure the quality and safety of your machine and to maintain the warranty, you **MUST** use original equipment manufactures replacement parts and have any repair work done by a qualified professional.

ALL operators of this equipment must be thoroughly trained BEFORE operating the equipment.

Do not use compressed air to clean grinding dust from the machine. This dust can cause personal injury as well as damage to the grinder. Machine is for indoor use only. Do not use a power washer to clean the machine.



Low Voltage Relay



The grinder is equipped with a low voltage relay which is factory preset at 100 VAC. If the power supply line does not deliver 100 VAC power under load, the relay will open and trip out the starter. If this occurs, your power supply line is inadequate and must be correct before proceeding further with the grinder.

CONTENTS

Safety Warnings	Page 2-4
Service Data	Page 5
Assembly Instructions	Page 6-10
Maintenance Instructions	Page 11-14
Adjustments	Page 15-24
Machine Service	Page 25-26
Electrical Troubleshooting Index	Page 28
Electrical Troubleshooting	Page 29-48
Mechanical Troubleshooting	Page 50-51
Parts Lists	Page 52-89
Electrical Diagrams	Page 90-97

-Separate Drawings Included in the Product Packet

SPECIFICATIONS

Electrical Requirements	115V 50/60 Hz, 20 amp circuit
Net Weight	2300 lbs [1045 kg]
Shipping Weight	2500 lbs [1140 kg]
Maximum Grinding Length	34 in. [86 cm]

SERVICE DATA

SKILL AND TRAINING REQUIRED FOR SERVICING

This Service Manual is designed for technicians who have the necessary mechanical and electrical knowledge and skills to reliably test and repair the *ACCU*-Master Grinder. For those without that background, service can be arranged through your local distributor.

This Manual presumes that you are already familiar with the normal operation of the Grinder. If not, you should read the Operators Manual, or do the servicing in conjunction with someone who is familiar with its operation.

Persons without the necessary knowledge and skills should not remove the control box cover or attempt any internal troubleshooting, adjustments, or parts replacement.

If you have questions not answered in this manual, please call your distributor. They will contact the manufacturer if necessary.

TORQUE REQUIREMENTS

Throughout this manual we refer to torque requirements as "firmly tighten" or the like. For more specific torque values, refer to the information below.

Bolts Going Into a Nut, or Into a Thread Hole in Steel

Refer to the table at the right.

Bolts Going Into a Thread Hole in Aluminum

Use the Grade 2 values in the table at the right.

Socket-Head Screws Going Into a Nut or Steel



Use the Grade 8 values in the table at the right.

Machine Screws

No. 6 screws: 11 in.-lbs (0.125 kg-m)

No. 8 screws: 20 in.-lbs (0.23 kg-m)

No. 10 screws: 32 in.-lbs (0.37 kg-m)

	GRADE 2  SMOOTH HEAD	GRADE 5  3 MARKS on HEAD	GRADE 8  6 MARKS on HEAD
1/4 In. thread	6 ft-lbs (0.8 kg-m)	9 ft-lbs (1.25 kg-m)	13 ft-lbs (1.8 kg-m)
5/16 In. thread	11 ft-lbs (1.5 kg-m)	18 ft-lbs (2.5 kg-m)	28 ft-lbs (3.9 kg-m)
3/8 In. thread	19 ft-lbs (2.6 kg-m)	31 ft-lbs (4.3 kg-m)	46 ft-lbs (6.4 kg-m)
7/16 In. thread	30 ft-lbs (4.1 kg-m)	50 ft-lbs (6.9 kg-m)	75 ft-lbs (10.4 kg-m)
1/2 In. thread	45 ft-lbs (6.2 kg-m)	75 ft-lbs (10.4 kg-m)	115 ft-lbs (15.9 kg-m)

ASSEMBLY INSTRUCTIONS (Continued)

Remove the carton and remove the contents from the carton onto a workbench. The carton includes: (See Parts List in back of this manual for Part Numbers.)

- Spreader Bar Assembly
- Product Package: Includes Operators Manual
Assembly & Service Manual
Warranty Card
Warning Instruction Sheet
Vacuum Manual
Wiring Diagrams
- Spin Drive Coupler Assembly
- Grinding Wheels (3)
- Bulb & Lens for Flashing light
- Reel Position Gage
- Drip Pan Assembly
- Alignment Gage Assembly

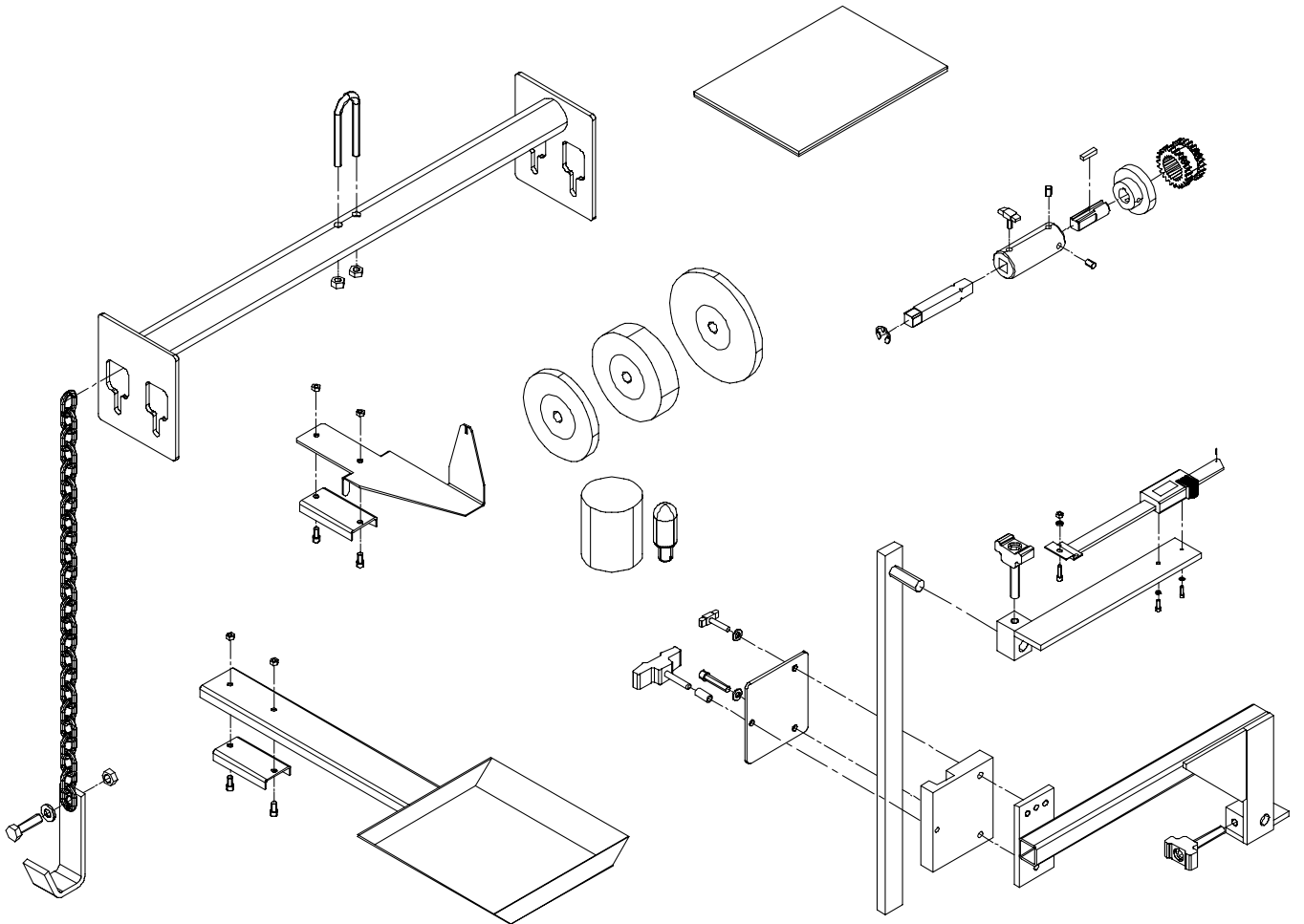

ASSEMBLY INSTRUCTIONS (Continued)

LEVEL BASE

Each leveling foot has been factory pre-adjusted so it protrudes from the base 2 1/4" [57 mm]. See FIG. 3. Place a level on the top of the table and check the levelness of the unit from side to side. Adjust the leveling feet as necessary to bring to level. See FIG. 4.

Place a level across the table from front to rear. Adjust the leveling feet on the end of the machine as necessary to level. See FIG. 5.

When both front to back and side to side leveling procedures have been completed, thread the hex jam nuts up against the nut that is welded to the bottom until they lock into place. Be careful not to move the leveling feet during this process. See FIG. 3. Make certain that all four leveling feet are firmly contacting the floor.

Recheck with level after locking nuts are firmly tightened.

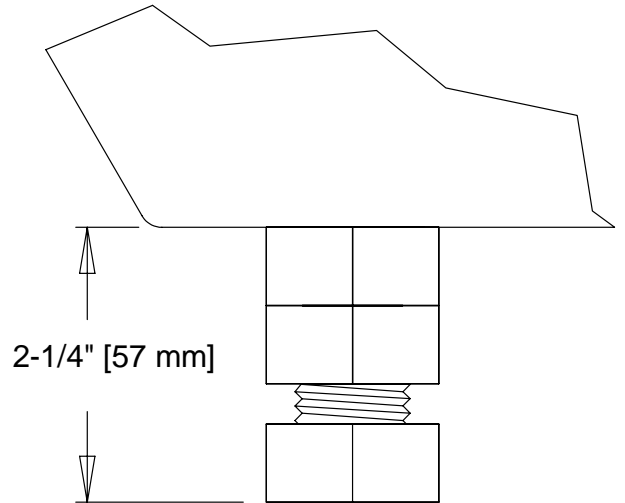

FIG. 3

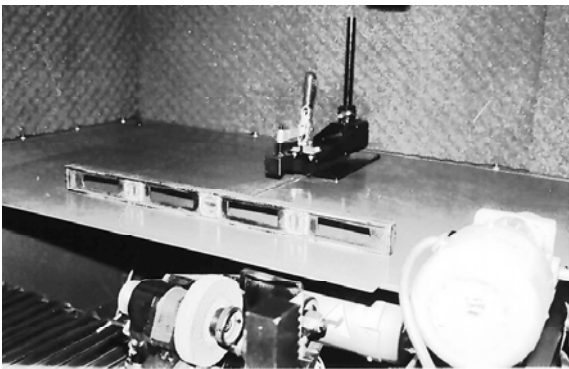

FIG. 4

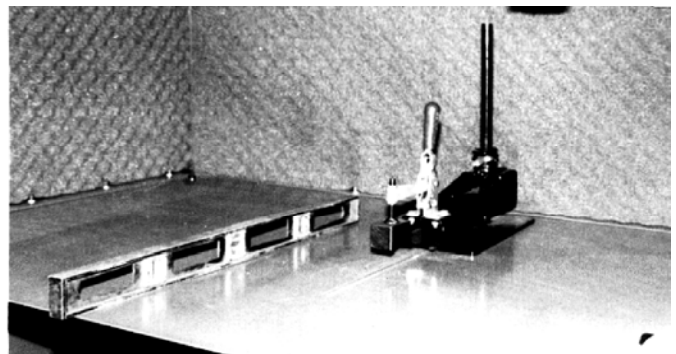

FIG. 5

INSTALL THE FLASHER LIGHT

Locate flasher bulb and lense in carton. Install bulb and lense to the flasher assembly socket located on the top of the right canopy door. See Fig. 6.

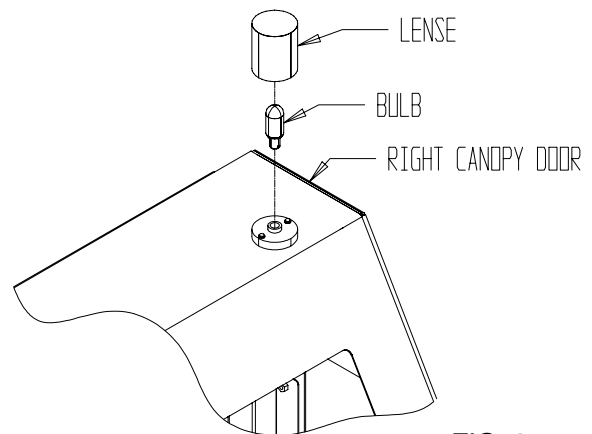

FIG. 6

ASSEMBLY INSTRUCTIONS (Continued)

APPLY POWER



BEFORE YOU APPLY POWER TO THE GRINDER, REFER TO THE "IMPORTANT GROUNDING INSTRUCTIONS" ON PAGE 10.

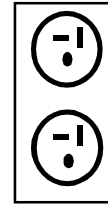

115 Volt Model Only. Plug the power cord into a standard 115V AC 20-amp grounded receptacle. See FIG. 7.

FIG. 7

220 Volt Model Only. For 220 Volt Applications order Part No. 6500952, which includes a prewired 3 KVA 220 V step down to 115 V 50-60 Hz transformer should be ordered..

IT IS RECOMMENDED THAT THIS ACCU-MASTER REEL MOWER GRINDER HAS ITS OWN PERMANENT POWER CONNECTION FROM THE POWER DISTRIBUTION PANEL, WITH NO OTHER MAJOR POWER DRAW EQUIPMENT ON THE SAME LINE.

The grinder is equipped with a low voltage relay which is factory preset at 100 VAC. If the power supply line does not deliver 100 VAC power under load, the relay will open and trip out the starter. If this occurs, your power supply line is inadequate and must be correct before proceeding further with the grinder.

IT IS REQUIRED THAT THE POWER DELIVERED TO THIS GRINDER IS 115 VAC - 20 AMPS. THE TOLERANCE ON THIS POWER REQUIREMENT IS +/- 5%. THEREFORE THE MINIMUM VOLTAGE REQUIREMENT IS 109VAC WITH 20 AMPS. VOLTAGE MUST BE CHECKED WITH ALL EQUIPMENT UNDER LOAD (OPERATING) ON THE CIRCUIT.

DO NOT OPERATE THIS GRINDER WITH AN EXTENSION CORD.

PROPER GROUNDING OF THE RECEPTACLE GROUND IN YOUR BUILDING MUST BE VERIFIED. IMPROPER GROUNDING IN YOUR BUILDING MAY CAUSE THE GRINDER TO MALFUNCTION.



FOR 20 AMP RATED LARGE MACHINES

Below is a list of required wire size in **your** building.

For 0 to 40 Feet from panel to receptacle = Use 12 Ga. Wire.

For 40 to 60 Feet from panel to receptacle = Use 10 Ga. Wire.

For 60 to 100 Feet from panel to receptacle = Use 8 Ga. Wire.

For 100 to 160 Feet from panel to receptacle = Use 6 Ga. Wire.

For 0 to 12 Meters from panel to receptacle = Use 2.5mm Wire.

For 12 to 30 Meters from panel to receptacle = Use 4.0mm Wire.

ASSEMBLY INSTRUCTIONS (Continued)

For 220 V 50 or 60Hz applications Product No. 6500952 should be ordered.

6500952 includes a 3 KVA 220 Volt Step Down to 115 volt 50/60 Hz transformer which is prewired.

The wiring diagram is shown in FIG. 8.

The power cord has no connector. A connector which is appropriate for your locality and 220 volt, 10 amp application should be installed.



Use only a qualified electrician to complete the installation.

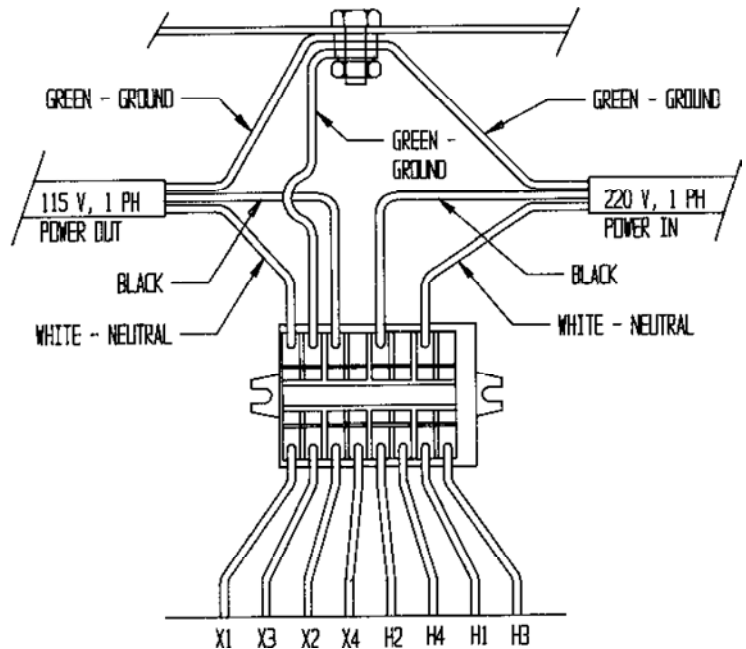

FIG. 8

IMPORTANT GROUNDING INSTRUCTIONS

In case of a malfunction or breakdown, grounding reduces the risk of electrical shock by providing a path of least resistance for electrical current.

This Grinder has an electrical cord with an equipment grounding conductor and a grounding plug. The plug must be plugged into a matching outlet that is properly installed and grounded according to all local or other appropriate electrical codes and ordinances.

Before plugging in the Grinder, make sure it will be connected to a supply circuit protected by a properly-sized circuit breaker or fuse.

Never modify the plug provided with the machine--if it won't fit the outlet, have a proper outlet and circuit installed by a qualified electrician.



ALWAYS PROVIDE A PROPER ELECTRICAL GROUND FOR YOUR MACHINE. AN IMPROPER CONNECTION CAN CAUSE A DANGEROUS ELECTRICAL SHOCK. IF YOU ARE UNSURE OF THE PROPER ELECTRICAL GROUNDING PROCEDURE, CONTACT A QUALIFIED ELECTRICIAN.

PERIODIC MAINTENANCE

DAILY MAINTENANCE IS SPECIFIED ON PAGE 4 OF THE OPERATOR'S MANUAL, AND IS TO BE PERFORMED BY THE OPERATOR.

LISTED BELOW ARE PERIODIC MAINTENANCE ITEMS TO BE PERFORMED BY YOUR COMPANY'S MAINTENANCE DEPARTMENT:

1. Clean the internal bag and cloth filter in the vacuum system weekly or more often depending on the number of reels ground.
2. Use the grease fitting provided to grease the dovetail with high quality lithium grease monthly. Wipe off excess grease. See FIG. 9.
3. Wipe and re-oil with spray lubricant, the grinding wheel diameter adjusting lead screw every three months. Wipe off all excess lubricant. See FIG. 8.
4. Check the gib adjustment on the grinding wheel diameter adjustment every 3 months. See FIG.8.
5. Inspect the Poly-V belt for cracking and adjust the belt tension per procedure called out in the adjustment section every six months.
6. Wipe and relub with never-seez, the vertical and horizontal alignment shafts and lead screws, every six months. See FIG. 10.
7. Lift the bellows and wipe off the traverse driveshaft and the bearing rails monthly. When a squeaking noise is coming from the actuator bearings, follow the lubrication procedure for actuator and linear bearings. Generally, this will be every six months to a year.

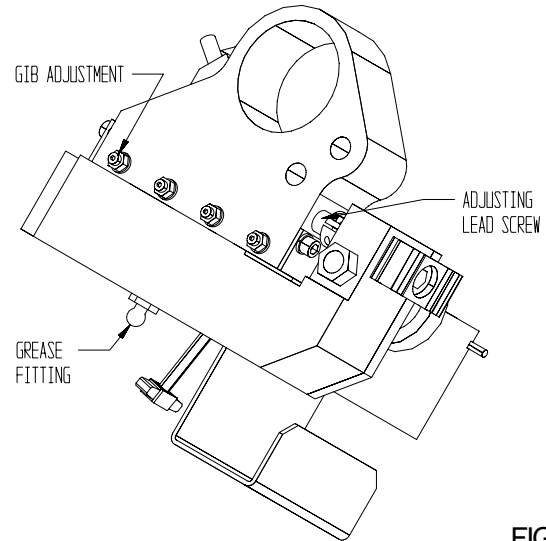

FIG. 9

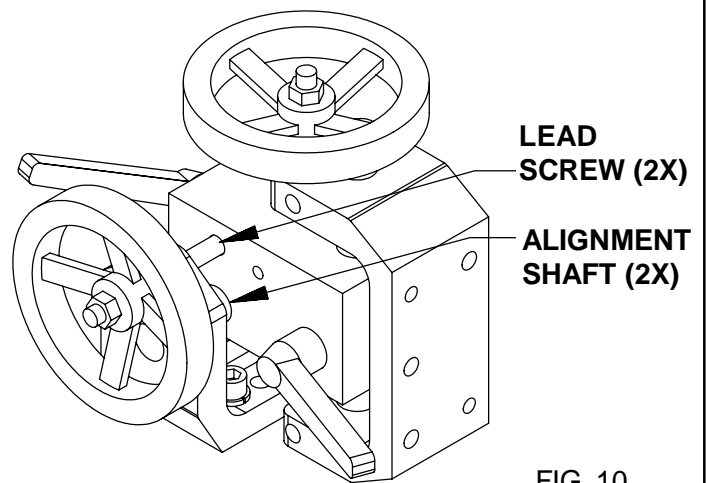

FIG. 10

LUBRICATION

LUBRICATION OF ACTUATOR AND LINEAR BEARINGS

STEP 1--Thoroughly clean all three shafts.

See FIG. 10.

STEP 2--Flood spray all three shafts with a spray lubricant (*do not use a teflon based lubricant*) until the lubricant is dripping off the shafts. Then run the carriage back and forth through its range of travel. This will carry the lubricant into the actuator and bearings.

NOTE: Because of the flood of lubricant you may find that the actuator slips and traversing is erratic or stalls. This is not a problem as it will be corrected in the subsequent steps.

STEP 3--With a clean rag, wipe off the excess amount of lubricant from the shafts. Run the carriage back and forth through its range of travel and wipe the shafts after each traverse. Repeat until the shafts are dry to the feel. This completes the lubrication process.

If the unit will be shut down for an extended period of time, more than four weeks, then the shafts and other appropriate parts of the unit should be flooded with lubricant and that lubricant left in place until the unit is brought back into service. When the unit is brought back into service the full lubrication procedure as stated above should be repeated.

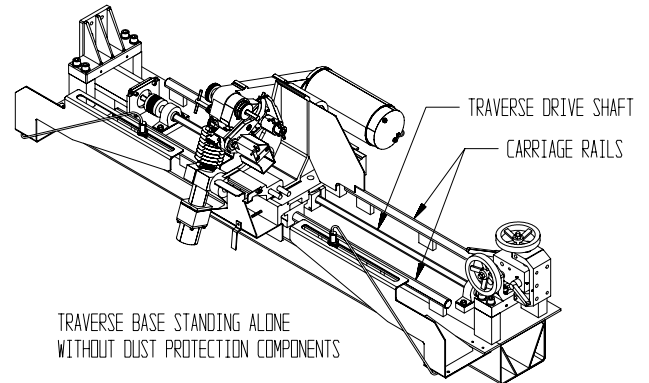

FIG. 10

MAINTENANCE (Continued)

CLEANING AND MAINTENANCE GUIDELINES FOR POLYCARBONATE WINDOWS

Cleaning Instructions



DO NOT USE GASOLINE

Adherence to regular and proper cleaning procedures is recommended to preserve appearance and performance.

Washing to Minimize Scratching

Wash polycarbonate windows with a mild dish washing liquid detergent and lukewarm water, using a clean soft sponge or a soft cloth. Rinse well with clean water. Dry thoroughly with a moist cellulose sponge to prevent water spots. Do not scrub or use brushes on these windows. Also, do not use butyl cellosolve in direct sunlight.

Fresh paint splashes and grease can be removed easily before drying by rubbing lightly with a good grade of VM&P naphtha or isopropyl alcohol. Afterward, a warm final wash should be made, using a mild dish washing liquid detergent solution and ending with a thorough rinsing with clean water.

Minimizing Hairline Scratches

Scratches and minor abrasions can be minimized by using a mild automobile polish. Three such products that tend to polish and fill scratches are Johnson paste Wax, Novus Plastic Polish #1 and #2, and Mirror Glaze plastic polish (M.G. M10). It is suggested that a test be made on a corner of the polycarbonate window with the product selected following the polish manufacturer's instructions.

Some Important "DON'TS"

- ◆ **DO NOT** use abrasive or highly alkaline cleaners on the polycarbonate windows.
- ◆ **Never** scrape polycarbonate windows with squeegees, razor blades or other sharp instruments.
- ◆ Benzene, gasoline, acetone or carbon tetrachloride should **NEVER** be used on polycarbonate windows.
- ◆ **DO NOT** clean polycarbonate windows in hot sun or at elevated temperatures.

Graffiti Removal

- Butyl cellosolve, (for removal of paints, marking pen inks, lipstick, etc.)
- The use of masking tape, adhesive tape or lint removal tools works well for lifting off old weathered paints.
- To remove labels, stickers, etc., the use of kerosene, VM&P naphtha or petroleum spirits is generally effective. When the solvent will not penetrate sticker material, apply heat (hair dryer) to soften the adhesive and promote removal.

GASOLINE SHOULD NOT BE USED!

MAINTENANCE (Continued)

DIGITAL GAGE

Important

- t t Do not mark the scale unit with an electric engraver or scratch the scale.
- t t **Always use an SR44 battery (silver oxide cell)**
- t t If the scale will not be used for more than three months, remove the battery and store it properly. Otherwise, leakage, if any, from the battery may damage the unit.

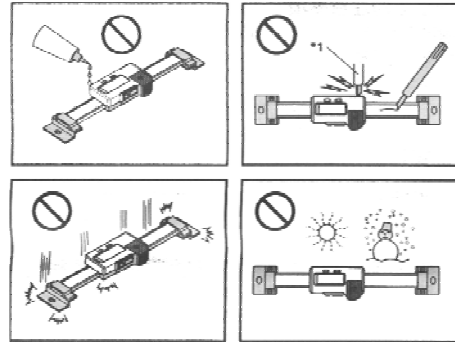

Description of Parts

- | | |
|------------------------|--------------------|
| 1. Beam | 2. Main Scale |
| 3. Battery compartment | 4. Outp Connection |
| 5. Display | 6. ON/OFF Power |
| 7. ZERO/ABS switch | 8. Origin Switch |
| 9. Inch/mm Switch | 10. Tapped hole |
| 11. Slider | |

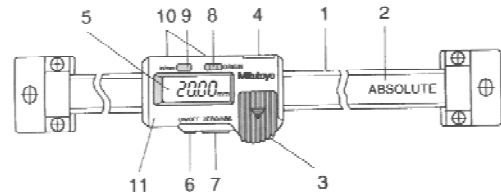

Battery Installation and Origin Setting

Set the origin of the scale after installing the battery. Otherwise, the error sign("E" at the least significant digit) may appear, resulting in incorrect measurements.

- 1) To install the battery, remove the compartment lid and install the SR44 battery with its positive side facing up. After the battery is installed, set the origin.
- 2) To set the origin, move the slider to an area you wish to set as your origin. Turn the power on. Hold the ORIGIN switch down for more than one second. The "0.00" display appears, indication Origin setting is complete. The origin will be retained even if the power is turned off.

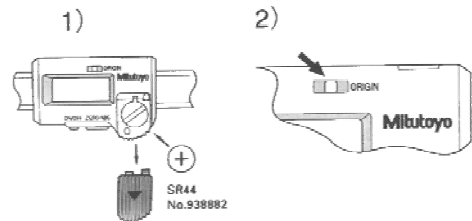

Incremental (INC) & Absolute (ABS) mode

The LCD will display measurements from the origin when turned on (ABS mode). To set the origin see above. The display can be set to zero at any desired position by pressing the ZERO/ABS switch. INC indicator will appear in the display (INC mode), permitting measurements from this zero point. To return to the ABS mode hold the ZERO/ABS button for more than 2 seconds.

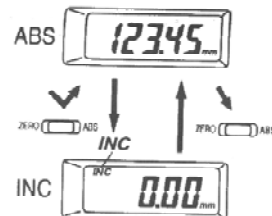

Error Symptoms & Remedies

- ◆◆ **ERRC and display flickering:** Occurs when the scale surface is stained. Clean the scale surface and coat a thin film of low viscosity oil to keep out moisture.
- ◆◆ **E in the least significant digit:** This occurs when the slider is moved too quickly, but it does not affect the measurement. If it stays on when the slider stops, the scale surface is probably stained. If this is the case, take remedies as for ErrC.
- ◆◆ **B indication:** Battery voltage is low. Replace the battery as soon as possible.

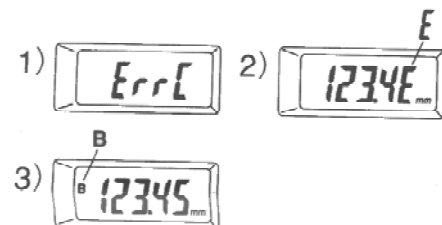

ADJUSTMENTS

LINEAR ACTUATOR BEARING REPLACEMENT

NOTE: It is not necessary to remove the linear actuator from the driveshaft--Remove only the bearings.

STEP 1--Remove the shoulder bolt from the top side of carriage. See FIG. 11.

STEP 2--Turn the actuator release lever 1/2 turn clockwise to release the actuator from the drive shaft. Slide the actuator release lever out of actuator bar assembly by loosening the retainer shaft collar, which preloads the holding spring. See FIG. 12.

STEP 3--Move the grinding head carriage to the left side. Lift the bellows. Remove shoulder bolts fastening the six bearings to the actuator body. See FIG 13. Remove the old bearings from the shoulder bolt, and discard, saving the inside washer. Insert the shoulder bolts through the new bearings and the saved inside washers. Then install these assemblies into the actuator body and tighten the shoulder bolts.

STEP 4--Slide the carriage over the actuator assembly to line up the hole in the carriage with the tapped hole in the actuator. Insert the shoulder bolt through self aligning bearings and tighten.

NOTE: Take extra caution not to cross the thread shoulder bolt.

STEP 5--Slide actuator release lever with collar, spring washer and foam seal back into actuator bar assembly and lock in place with retainer shaft collar. See FIG. 12. Turn actuator release lever 1/2 turn counterclockwise to engage bearings to drive shaft.

STEP 6--Using a spring scale, connect the scale to the carriage to pull on the carriage parallel to actuator drive shaft. Then while holding the drive shaft from rotating, pull on carriage; the pull force should be 60 lbs. (See Step 7 for readjustment if necessary.)



THE PULL FORCE IS TO BE CHECKED WHEN SHAFT IS WIPED CLEAN AND DRY. IF CHECKED WHEN OILY, TOO MUCH TENSION WILL BE SET AND AFFECT BEARING LIFE.

STEP 7--If readjustment is required to achieve pull force within specification, with actuator bearings engaged to drive shaft, readjust the two outboard screws with springs that hold the actuator together. See FIG 13. To reach these screws, the actuator bar assembly must be removed. Turn each screw an equal amount when resetting for more or less tension, clockwise is more tension. Repeat Step 6 and verify pull force. Continue to adjust until within specification. The factory preadjusted spring tension is .160 or 5/32" [4 mm] from under the washer holding the spring to the actuator block. See FIG. 12. This should give the 60 lbs. carriage pull force specified.

When adjustment is correct reinstall the actuator bar assembly. The bar assembly must be adjusted parallel to the actuator aluminum body and so it is just touching the outboard screw heads. Then tighten the lock nut on the lower actuator bar assembly mounting screw. See FIG. 12. Then reinstall the release lever package as above.

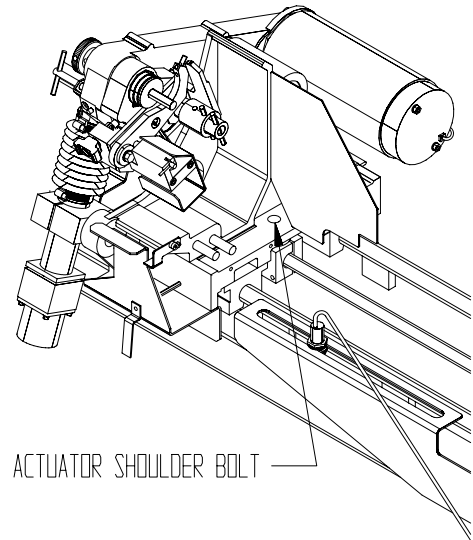

FIG. 11

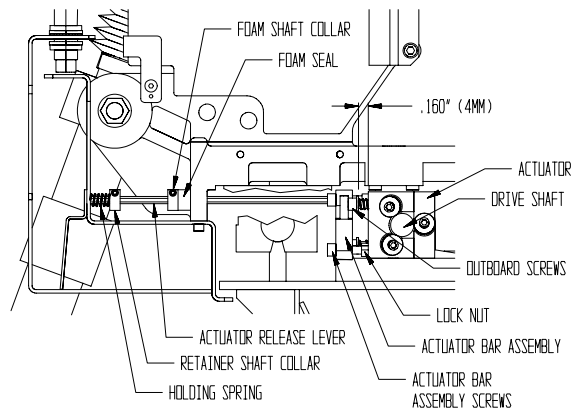

FIG. 12

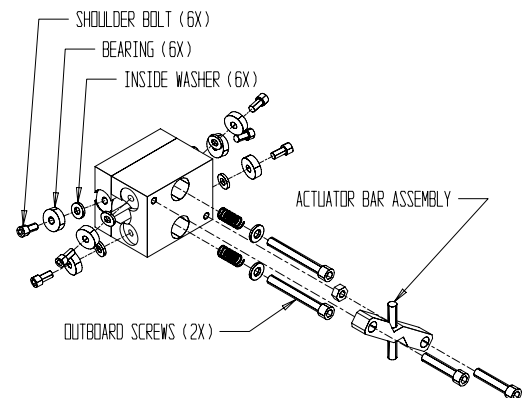

FIG. 13

ADJUSTMENTS (Continued)

CARRIAGE LINEAR BEARING REPLACEMENT

STEP 1--Detach the bellows mounting brackets from the carriage. Detach front and rear shields. See FIG. 15.

STEP 2--Remove the three screws of one linear bearing and slide the linear bearing off the end of the carriage shaft.

STEP 3--Insert a new linear bearing onto the end of the carriage shaft with the tension adjustment screw pointing outward. See FIG. 14. Adjust the tension screw of the linear bearing so when you radially rotate the linear bearing around the carriage shaft there should be no free play between the linear bearing and the carriage shaft.

NOTE: Tension is too tight if you feel a cogging action when you rotate linear bearing around the shaft. This cogging is from the skidding of the bearing on the shaft and indicates tension screw is too tight.

Finally, sliding the bearing block back and forth should be a smooth uniform motion.



SETTING THE BEARING TENSION CORRECTLY IS CRITICAL TO PROPER GRINDING. BEARINGS WHICH ARE TOO TIGHT OR TOO LOOSE WILL CAUSE POOR GRIND QUALITY. ALSO, BEARINGS WHICH ARE TOO TIGHT WILL HAVE SUBSTANTIALLY SHORTER LIVES AND MAY DAMAGE THE SHAFT.

STEP 4--Slide linear bearing under carriage and attach with the three screws.

NOTE: Repeat Steps 2 thru 4 with the other three linear bearings.

STEP 5--After all four linear bearings are reattached to the carriage check for correct bearing tension. The bearing tension is correct when you try to lift the carriage and can feel no carriage movement, which is free play up and down. The most dependable method of checking free play is to use a magnetic base dial indicator attached to the traverse frame weldment and reading the vertical movement above each bearing. This movement should be within .001" [.03 mm]. Also, when pulling the carriage in the traversing direction, there should be only approximately a 3 lb force, with the actuator disengaged, using a scale system similar to Step 6 of Linear Actuator Bearing Replacement Section in this manual. To double check the assembly, slide the carriage assembly from "end of travel" to "end of travel", it should have very uniform resistance through the full range of travel.

STEP 6--Replace the bellows carriage mounting brackets onto the carriage. Replace front and rear shields. See FIG. 15.

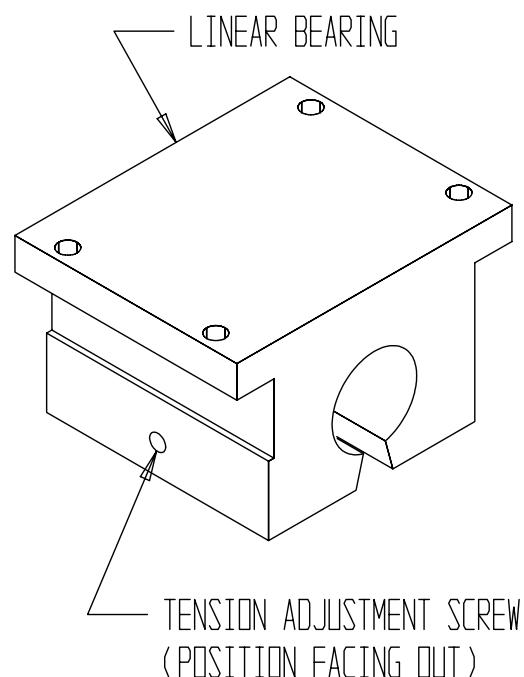

FIG. 14

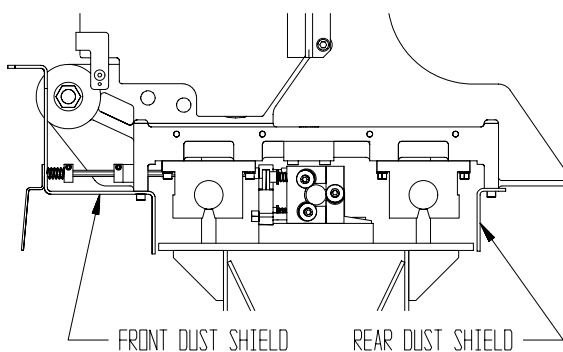

FIG. 15

ADJUSTMENTS (Continued)

REEL FINGER DOVETAIL GIB AND ADJUSTING KNOB ADJUSTMENTS

The reel finger slide to the reel finger positioner has a dovetail with an adjustable gib for tensioning. Tighten the gib set screws on the side so there is no free play in the dovetail slide. Check for movement when pushing on the relief finger side to side with a 20 lbs. (44 kg) force. Make sure the knob assembly for adjusting the relief finger to the grinding wheel is rotatable by hand. The gib adjustment should be sufficient to maintain a rigid position of the reel finger. See FIG. 16.

Check the knob assembly rotating tension by checking the tightness of the nylon plug to the knob assembly threads. The tightness has to be sufficient so the knob assembly does not rotate during the relief grinding cycle. See FIG. 17. NOTE: To adjust the nylon plug you must lock the index finger assembly down and then adjust the reel finger positioner so the clearance holes line up with the nylon plug set screw.

Take up any free play between the tee knob assembly, reel finger slide and .375 threaded split shaft collar. Loosen the shaft collar locking cap screw and rotate the shaft collar until there is no end play. Retighten locking cap screw on the threaded split shaft collar. See FIG. 16.

GRINDING HEAD BELT TENSION ADJUSTMENT

The grip grinding wheel knob need not be removed for belt tensioning adjustment. Remove the six socket head cap screws holding the vacuum hose bracket, the two double tube clamps and the belt cover. For grinding motor belt adjustment, loosen the four socket head cap screws that attach the motor. Adjust the grinding motor for proper belt tension and tighten the four socket head cap screws. The proper belt tension for the grinding head is to push down on the poly V belt half way between to two pulleys with 5 lbs. [2 kg] of force and belt movement dimensions to be .12 inches [3 mm]. See FIG. 18. To verify belt tension mount the belt guard with two screws. Turn the motor on. If the belt is tensioned correctly, start-up torque of the motor through the pulley to the belt should have zero slippage. If there is belt slippage when turning on the motor there will be a slight squeal before the belt comes up to speed. When you achieve correct tension, reassemble all of the remaining parts that have been removed.

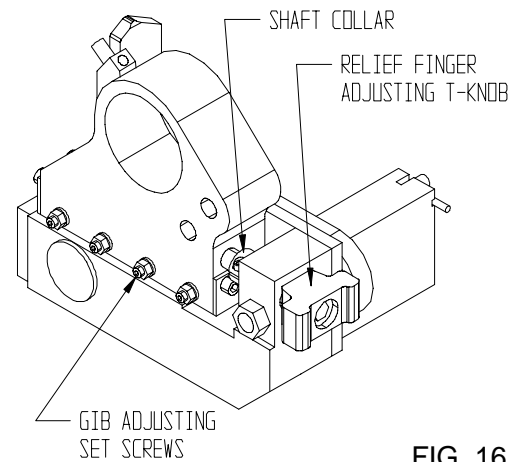

FIG. 16

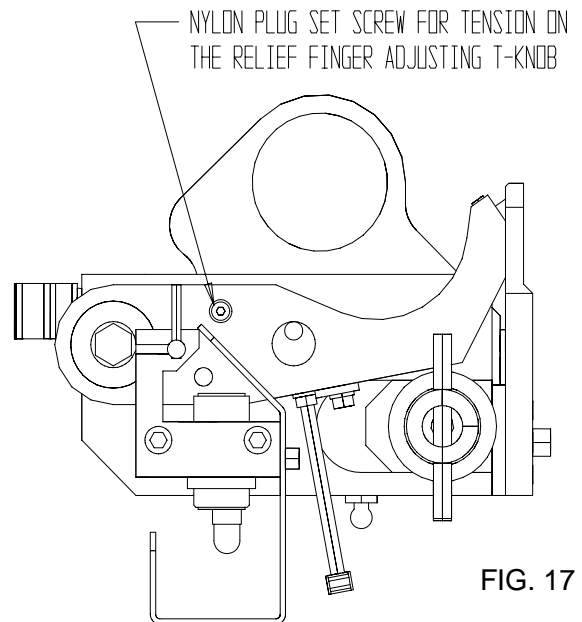

FIG. 17

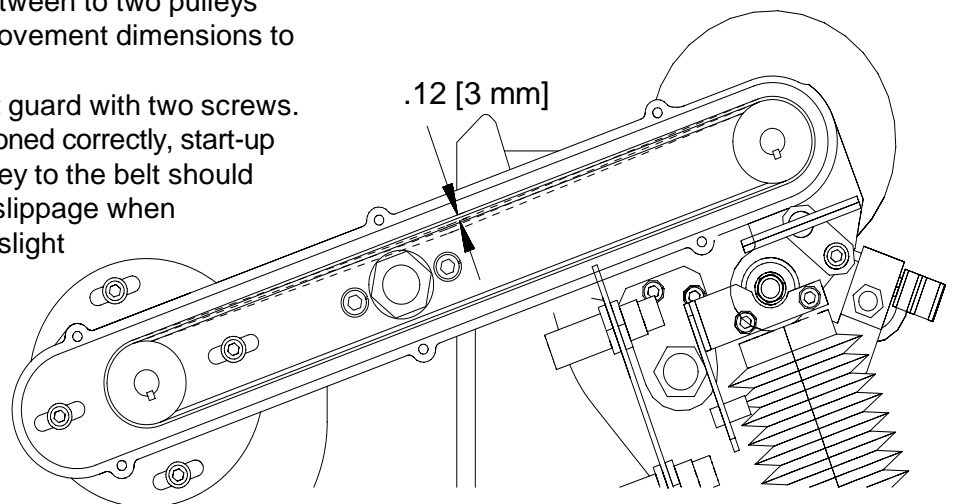

FIG. 18

ADJUSTMENTS (Continued)

INDEX FINGER PROXIMITY SETTING

Set all motor switches to the off position.

Press the machine system start switch, so the grinder is operational.

Push down on the index finger until the stop pin is within .06 inches (1.5 mm) of bottoming out. (You can use a 1/16" gage pin or rod stock between the stop pin and index finger). Set the proximity switch to activate the light at this setting. This assures the index finger to be close to its final stop position so the reel is completely indexed before the carriage starts to traverse. See FIG. 19.

The spring load force pushing up on the index finger brings it away from the proximity when released.

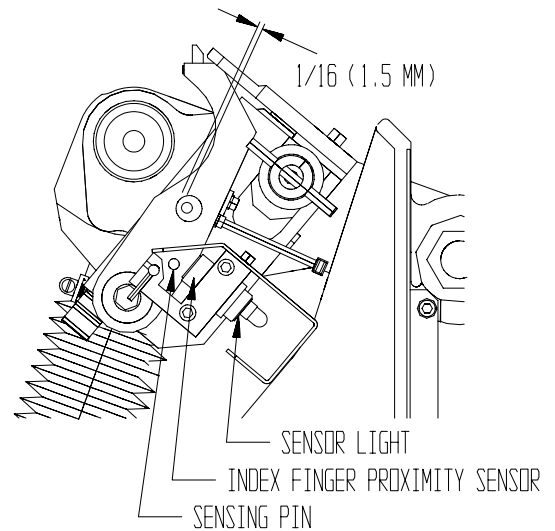

FIG. 19

STEPPER INFEEED TRAVEL LIMITS

The infeed stepper maximum extension is 6.0" (152 mm) and minimum compression is 3.5" (89 mm). If you experience a situation where the grind does not properly finish, check that you have not exceeded stepper travel by checking the values per FIG. 20.

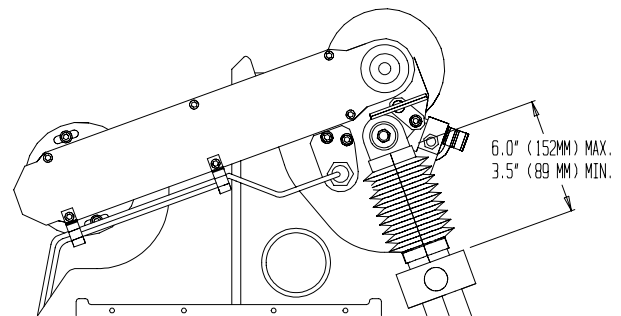

FIG. 20

LOCKING INDEX FINGER PIN

To align the Index Finger Locking Pin to the hole in the Index Finger Assembly loosen the two socket head cap screws so the index sensor block is movable. Push down on the index finger assembly until the spring loaded index finger locks into hole with no binding. Tighten the two socket head cap screws so the index sensor block is secured, and the locking pin moves freely. See FIG. 21.

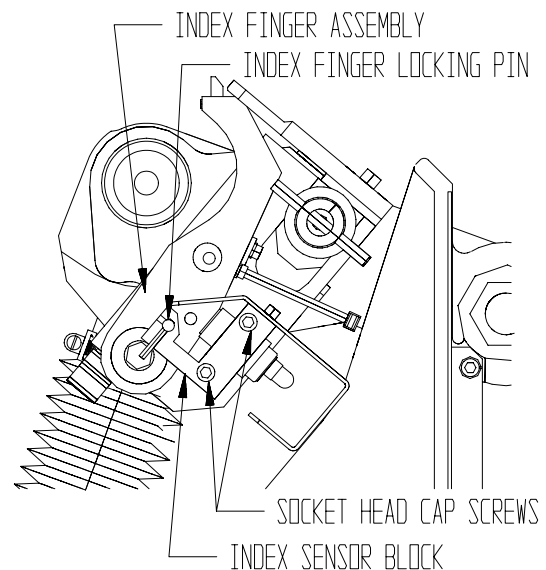

FIG. 21

ADJUSTMENTS (Continued)

PROXIMITY SWITCH

For the proximity switch to perform properly and reverse the direction of the carriage at each end of the rails, a distance of 3/16" [4 mm] to 1/4" [6 mm] needs to be maintained between the carriage proximity flag bracket and the proximity switch. See FIG. 22.

NOTE: The light on the proximity switch activates when metal crosses over the switch.

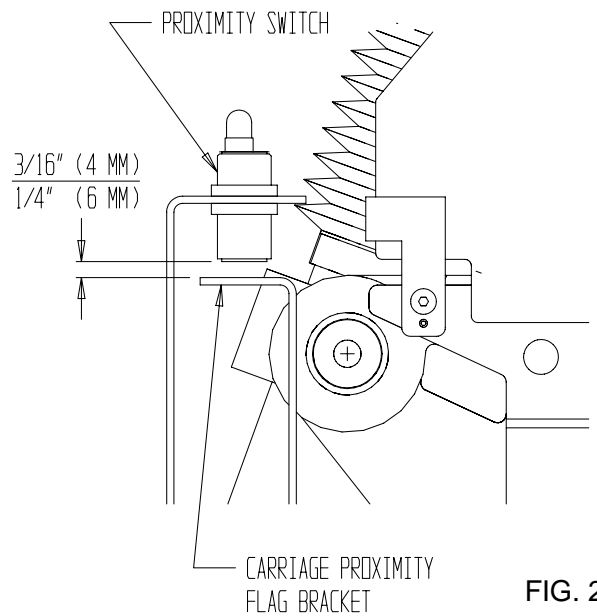

FIG. 22

ADJUSTABLE RELIEF TENSION

If the relief angle appears to vary during relief grinding adjust the tension on the nylon plug and set screw. See FIG. 23.

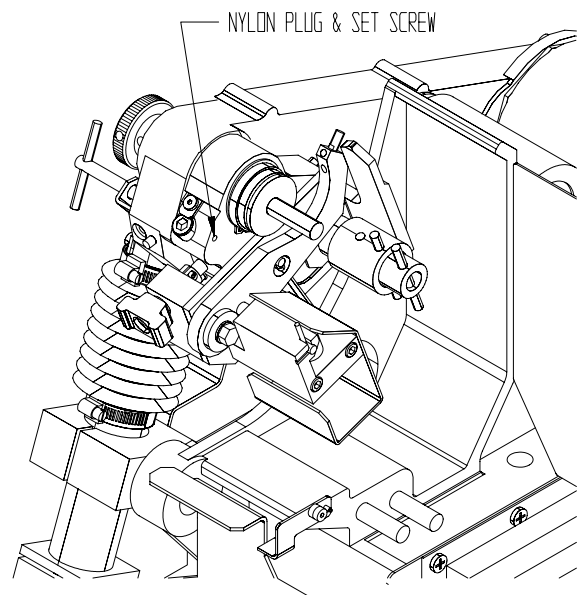

FIG. 23

ADJUSTMENTS (Continued)

SPIN GRINDING ATTACHMENT ADJUSTMENT

If free play develops so the crank handle wants to rotate with free play when operating in the scissor action (raising and lowering) on the spin grinding attachment, the free play can be eliminated by tightening the set screw identified in FIG. 24.

If there is too much play in the spin drive pivot points, torque down the hex nut tight so conical washer is compressed, then back off 1/2 turn. See FIG. 24.

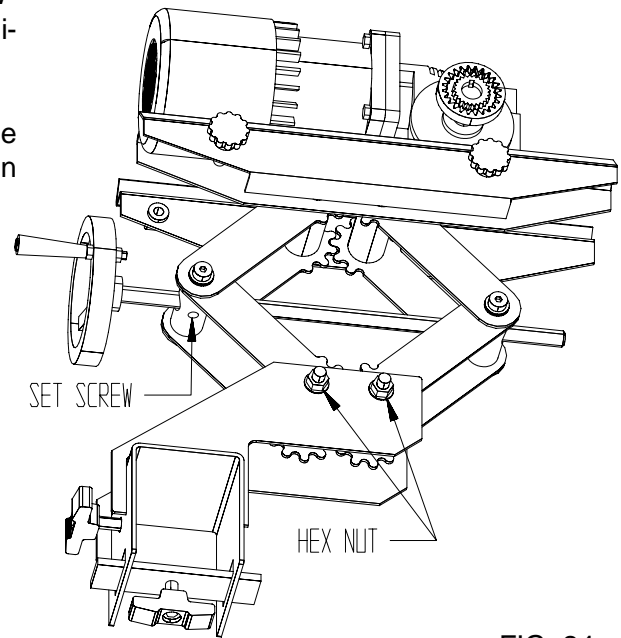

FIG. 24

TRAVERSE MOTOR COUPLING

Traverse motor shaft must be concentric to traverse drive shaft within .010. The traverse shaft and motor shaft are to have at least 1/8" [3 mm] to 1/2" [13 mm] clearance so they do not contact each other. The coupling is to be locked down tightly with the spiral grooves equally spaced for the full length. See FIG. 25.

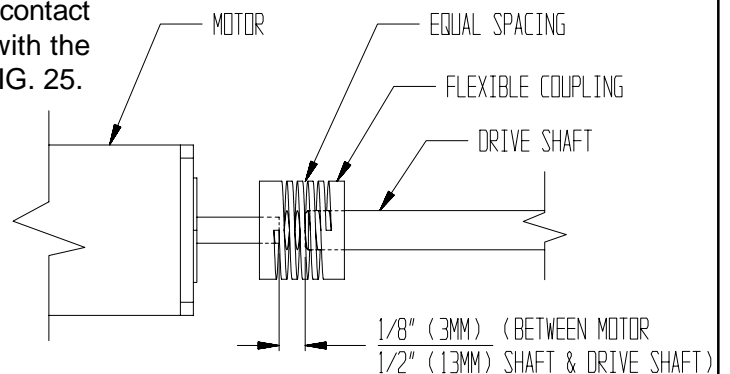

FIG. 25

ADJUSTMENTS (Continued)

ADJUSTING CROSS SLIDE ASSEMBLY

If the cross slide becomes very difficult to turn it may become necessary to adjust the assembly. To relieve the tension on the assembly follow the procedure listed below:

STEP 1--Using a hydraulic jack, raise the traversing carriage base just enough to alleviate the weight stress on the Cross Slide Assembly.

STEP 2--Knock out the pins on either side of the Mounting Frame Adjuster and loosen the 4 bolts (B504801) that connect the Carriage Mounting Frame to the frame of the grinder.

STEP 3--Jack the traversing carriage base up to put a preload on the Cross Slide Assembly.

STEP 4--Tighten the 4 bolts on the Carriage Mounting Frame to 75 ft-lbs.

STEP 5--Release the jack pressure and test the vertical and horizontal handwheels for ease of movement through their full range of motion.

STEP 6--If the Cross Slides tend to bind, repeat above steps jacking higher or lower (STEP 1) until the handwheels move freely.

STEP 7--When the Cross Slides move freely through their full range of motion, drill new holes and repin assembly.

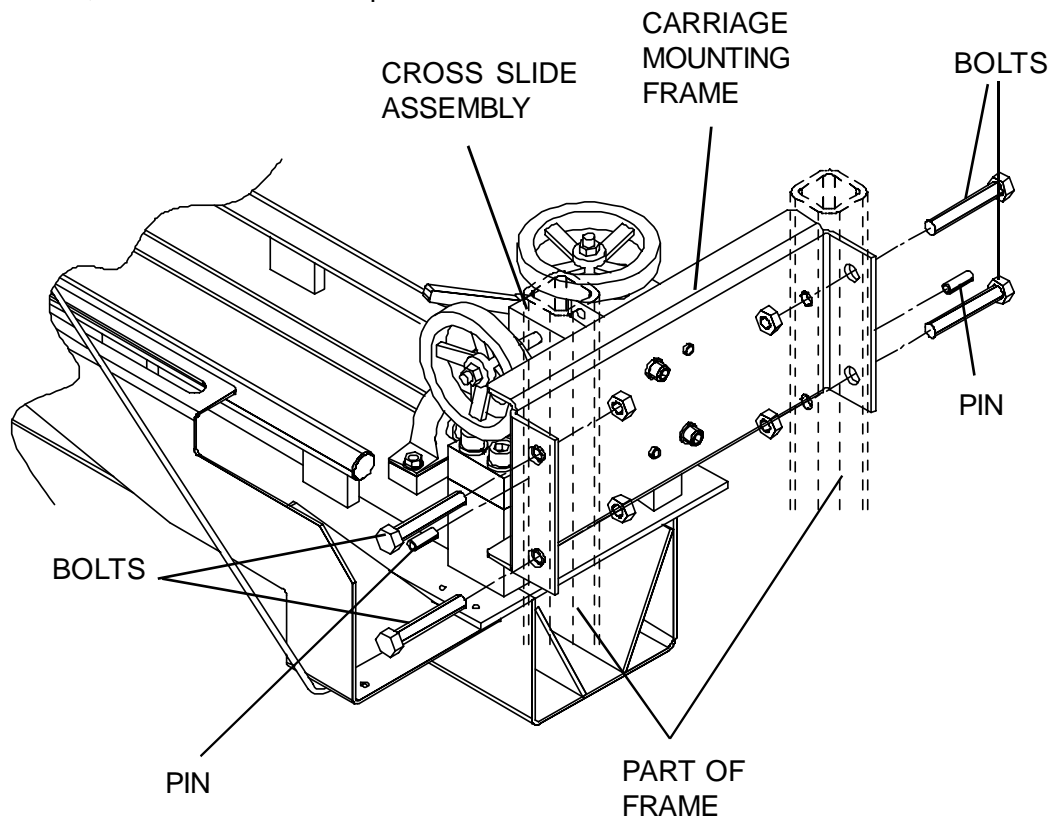

ADJUSTMENTS (Continued)

CROSS SLIDE SHAFT REPLACEMENT

If the cross slide shafts become scarred or gnarled, replace them by the following procedure:

STEP 1--Use a hydraulic jack to raise the weight off the Cross Slide Assembly.

STEP 2--Loosen the two nuts on the support casting that hold the dutchman and tap with plastic hammer to loosen.

STEP 3--Loosen the locking handles and tap the center stud with a plastic hammer.

STEP 4--Loosen locknut and setscrew and remove the handwheel.

STEP 5--Remove the Slide Shaft.

STEP 6--Remove all burrs and resurface the shaft to a clean, smooth, polished surface. (OR REPLACE WITH A NEW SHAFT.)

STEP 7--Coat shaft with Never-Cease and re-install the shaft through the Support, Cross Slide Block and the three Dutchman. The shaft must move freely inside the Cross Slide Block before reassembling.

STEP 8--Retightening the nuts at the end of the Dutchman to lock shaft in place.

STEP 9--Reinstall the Handwheel by snugging the setscrew to the flat located on the screw shaft, then torque nut until tight and back off 1/2 turn. Torque the setscrew to 70 in-lbs.

STEP 10--Test the Cross Slide, the handwheel should turn freely.

STEP 11--Lower the jack and retest the Cross Slide Assembly through full range of motion. If binding occurs, follow the procedure under Cross Slide Assembly located on page 21.

NOTE: It is also possible to remove the complete Cross Slide Assembly and do the repairs on a bench then reinstall.

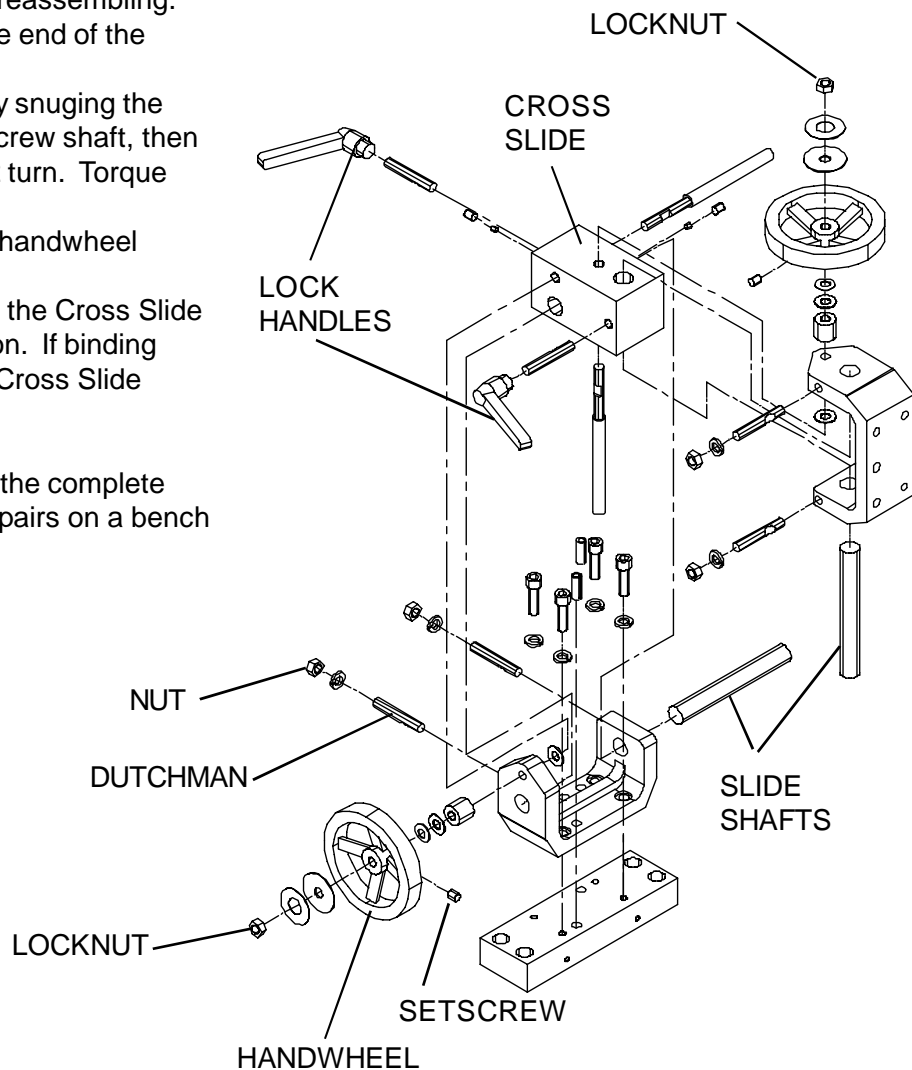
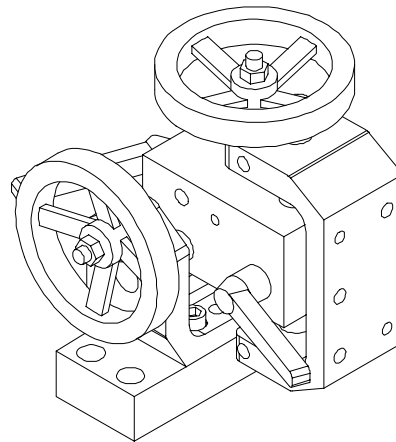

CONTROL BOARD POTENTIOMETER ADJUSTMENTS

SPIN DRIVE CONTROL BOARD (SDC)

The Spin Drive Control Board has three potentiometers on the lower board and two potentiometers on the upper board as shown on drawing 6504434 which is included. These potentiometers have been set at the factory to the positions shown on the drawing. Also see FIG. 27A and 27B.

In the Relief Grinding Mode---

The Remote Speed Pot and the Relief Torque Pot (RTP) interact with each other. The remote speed pot is located on the upper board of the Spin Drive Control (SDC) preset at 2:00 (20 Volts DC). The (RTP) is located on the control panel and is for relief torque adjustment. See FIG. 27B.

The Remote Speed Pot when rotated clockwise will increase maximum spin drive speed. This speed should never be above the 2:30 setting.

Relief Torque Pot (RTP) can vary the reel to finger holding torque for relief grinding. The recommended starting point is 15 in/lbs of torque setting. Never adjust the (RTP) potentiometer dial past the red line marking. Setting the reel to finger torque to high could cause the traverse motor system to not operating smoothly.

In the Spin Grinding Mode---

The Remote Torque Potentiometer and the Spin Speed Pot (SSP) interact with each other. The remote torque pot is located on the upper board of the Spin Drive Control (SDC) preset at 2:00 for torque setting. The (SSP) is located on the control panel and is for spin speed adjustment. See FIG. 27B.

The Remote Torque Potentiometer controls maximum torque allowable in the spin grind cycle only. This should never be adjusted past the 2:30 position.

The Spin Speed Pot (SSP) controls reel spin speed, adjust as required. This controls the spin drive speed for spinning the reel.

POTENTIOMETERS ON THE SPIN DRIVE CONTROL (SDC) LOWER BOARD See FIG. 27A.

Maximum Speed Pot---

The maximum speed is factory preset to 4:30 (fully clockwise) to allow for maximum spin speed.

Minimum Speed Pot---

The minimum speed is factory preset at 8:30 (full counterclockwise) so zero speed is obtainable for spin speed.

IR Compensation Pot---

The IR Compensation is factory set at 9:00.

Regulation of the spin or relief grind spin motor may be improved by a slight adjustment of the IR COMP trim pot clockwise from its factory-set position. Overcompensation causes the motor to oscillate or to increase speed when fully loaded. If you reach such a point, turn the IR COMP trim pot counterclockwise until the symptoms just disappear.

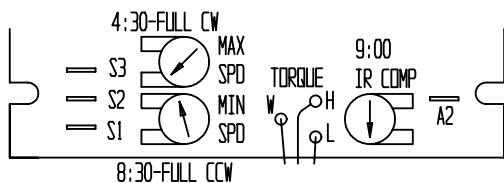

FIG. 27A

See potentiometer orientation on page 24

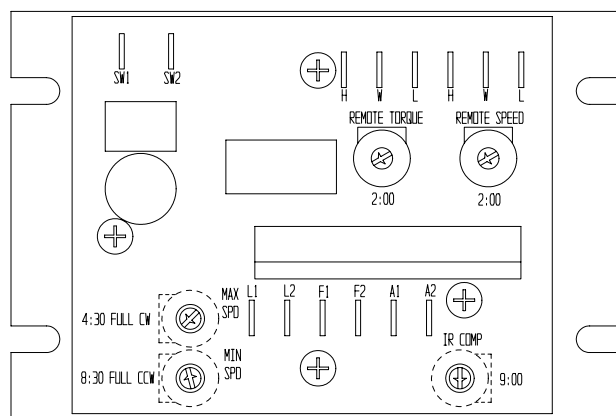

FIG. 27B

CONTROL BOARD POTENTIOMETER ADJUSTMENTS (Continued)

GRINDING MOTOR CONTROL BOARD (GMC)

The Grinding Motor Control Board has four potentiometers on the board as shown on drawing 6504434 which is included. These potentiometers have been set at the factory to the positions shown on the drawing. See FIG. 28.

Maximum Speed---

The maximum speed potentiometer is preset to 1:00 position for 95 Volts DC to the grinding motor for 4300 RPM. The 4300 RPM is for optimum grinding wheel operating speed. DO NOT go above the 4300 RPM. Check for 95 Volts DC on Grinding Motor Control (GMC) at Term A1 to Term A2.

Accel / Decel---

The accel/decel potentiometer is set full counterclockwise so it is nonfunctional for this application.

Current Limit---

The current limit is preset at 3:00 at the factory. Going above the current limit causes the motor to pulsate. The current limit can be turned clockwise to increase the motor's maximum torque for grinding overloads. The 10 amp circuit breaker on the control panel will trip if the overload persists for a prolonged period of time. Use a lower grinding head traverse speed if nuisance tripping is experienced.

IR Compensation---

Regulation of the grinder motor may be improved by slight adjustment of the IR COMP trim pot clockwise from its factory-set position. Overcompensation causes the motor to oscillate or to increase speed when fully loaded. If you reach such a point, turn the IR COMP trim pot counterclockwise until the symptoms just disappear.

The control is preset to 9:00 position. Never adjust past the 11:00 position when changing the setting to increase higher torque for heavy grinding.

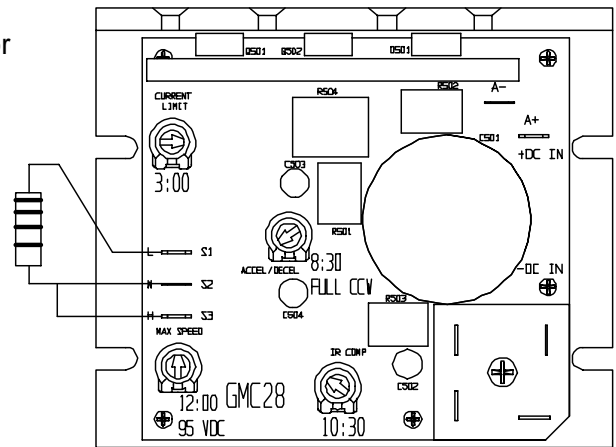
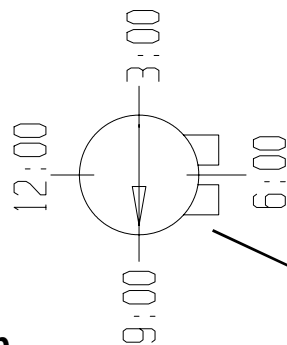

FIG. 28

Potentiometer Clock Orientation



Terminal ends (Feet) are always at the 6:00 position, no matter potentiometer orientation on the board.

MACHINE SERVICE

TRAVERSE DRIVE CONTROL BOARD (TDC)

The Traverse Drive Control Board has five potentiometers as shown on drawing 6504434 which is included. These potentiometers have been set at the factory to the positions shown on the drawing. Also see FIG. 29.

Maximum Speed---

The maximum speed potentiometer is preset to 10:30 position for 50 Volts DC to the traverse motor.

Rev Torque---

The Reverse Torque setting determines the maximum current limit for driving the motor in the reverse direction. The potentiometer is preset to the 3:00 position. It should not require adjustment.

Fwd Torque---

The Foward Torque setting determines the maximum current limit for driving the motor in the forward direction. The potentiometer is preset to the 3:00 position. It should not require adjustment.

Accel - Decel---

The potentiometer is factory preset to the minimum full counterclockwise 8:30 position. This position turns the Acceleration/Deceleration off for this application.

IR Compensation---

The IR Comp control is preset to 9:30 position. Never adjust past the 11:00 position.

Regulation of the traverse motor may be improved by slight adjustment of the IR COMP trim pot clockwise from its factory-set position. Overcompensation causes the motor to oscillate or to increase speed when fully loaded. If you reach such a point, turn the IR COMP trim pot counterclockwise until the symptoms just disappear.

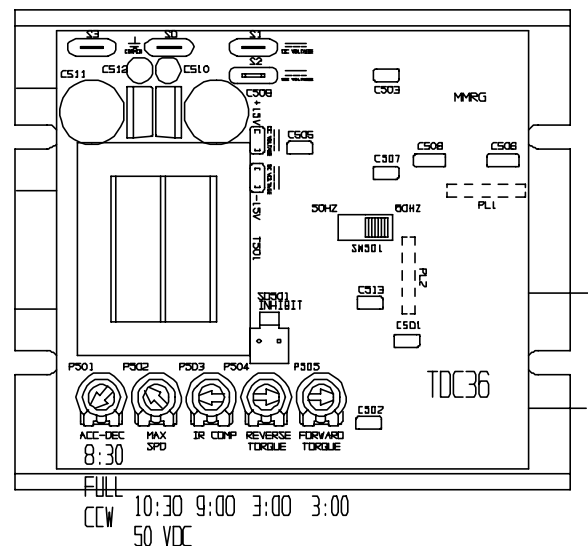

FIG. 29

MACHINE SERVICE (Continued)

GRINDING HEAD ASSEMBLY

Remove grinding wheel knob and grinding wheel. The Grinding Head Spindle Assembly consists of the grinding head spindle and a ball bearing press fit together. The other ball bearing is slip fit on the opposite end during assembly with loctite on the bearing bore. To replace the spindle assembly remove the grinding wheel grip knob, square key and belt cover. See FIG. 30. Loosen the 4 socket head cap screws on the motor to remove the poly-V belt. Loosen the 2 set screws on the spindle pulley and remove the pulley, square key and pulley spacer. Push on the right hand side of the spindle assembly to compress conical washers so there is no pressure on the shaft retaining ring and to expose the retaining ring for removal. Using a retaining ring pliers remove the small retaining ring from the spindle assembly. You can now remove the spindle assembly out the right side by lightly tapping on the left end with a rubber mallet. The second ball bearing can be removed from the belt side of the Grinding Head Housing.

To reassemble place the 4 conical washers (2 pair nested and then place the 2 pairs back to back) against the ball bearing on the new spindle assembly. See FIG. 31. Slide this assembly into the Grinding Head Housing and slip fit the new second ball bearing onto the spindle assembly and into grinding head housing (apply loctite #242 to the bore of the bearing before assembling). Using a C-clamp compress the conical washers so you can replace the retaining ring. The retaining ring is fragile and easily damaged when removing. Always use a new retaining ring when reassembling the grinding head spindle. Only open the retaining ring enough to install. Opening the ring excessively will damage the retaining ring, making it unusable.

Replace the pulley spacer and mount the square key positioned tight against the pulley spacer. Remount the pulley pushing against the pulley spacer and bottom out against the snap ring with no end play. Next tighten the two pulley set screws. Then remount the poly-V belt. (See Grinding Head Belt Tension Adjustment in the adjusting section). Replace belt cover and square key and mount the grinding wheel grip knob and tighten the two set screws.

THE RETAINING RING IS FRAGILE AND EASILY DAMAGED WHEN REMOVING. ALWAYS USE A NEW RETAINING RING WHEN REASSEMBLING THE GRINDING HEAD SPINDLE. ONLY OPEN THE RETAINING RING ENOUGH TO INSTALL. OPENING THE RING EXCESSIVELY WILL DAMAGE THE RETAINING RING, MAKING IT UNUSABLE.

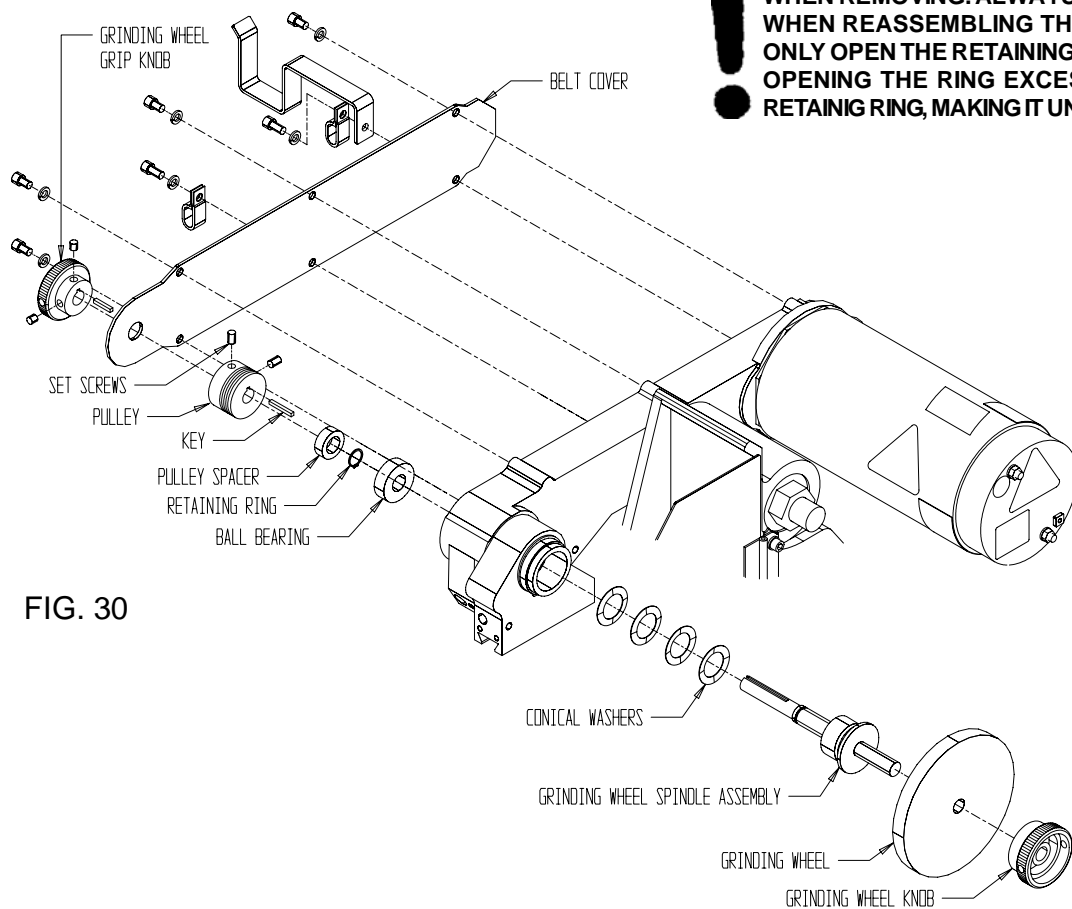

FIG. 31

-This page was left blank intentionally for note taking purposes-

ELECTRICAL TROUBLESHOOTING

SKILL AND TRAINING REQUIRED FOR ELECTRICAL SERVICING

This Electrical Troubleshooting section is designed for technicians who have the necessary electrical knowledge and skills to reliably test and repair the ACCU-Master electrical system. For those without that background, service can be arranged through your local distributor.

This manual presumes that you are already familiar with the normal operation of the Grinder. If not, you should read the Operators Manual, or do the servicing in conjunction with someone who is familiar with its operation.

Persons without the necessary knowledge and skills should not remove the control box cover or attempt any internal troubleshooting, adjustments, or parts replacement.

If you have any question not answered in this manual, please call your distributor. They will contact the manufacturer if necessary.

WIRE LABELS

All wires on the ACCU-Master have a wire label at each end for assembly and troubleshooting. The wire label has a code which tells you wiring information. The first set of digits are the schematic wire number: These identify the connection number. Look at the column numbers on the left side of the schematic rung to identify the wire(s) The next number(s) are the Foley wire number. The next group of numbers or letters are the code for the component to which the wire attaches. Example: RT1 for Relay Terminal 1. The last set of numbers or letters are the number of the terminal on the component to which the wire attaches.

ELECTRICAL TROUBLESHOOTING INDEX

AC Main Power Controls	Page 29
E-Stop	Page 30
Machine Light	Page 31
Spin Drive Controls in Spin Mode	Page 32-33
Spin Drive Controls in Relief Mode	Page 34-35
Grinding Motor Controls	Page 36-37
Dust Collector Controls	Page 38
Winch Controls	Page 39
Traverse Drive Controls--w/prox	Page 40-41
Stepper Infeed Controls--	Page 42-43
System Error Messages	Page 44-47
Flashing Light	Page 48

ELECTRICAL TROUBLESHOOTING (Continued)

PROBLEM--AC Main Power Controls: no electrical power to control panel.

In your Product Packet Assembly, there are a series of prints. Find the print titled 650-Wiring Diagram and Junction Box/Light Assembly, before starting the troubleshooting below. Verify all wires shown on that drawing are correct and pull on wire terminals with approximately 3 lbs force to verify there are no loose terminal connections and/or no loose crimps between wire and terminal. If loose terminals are found, retighten and retest system. If problem persists, test as listed below.

Possible Cause	Checkout Procedure	
You must turn ON the Switch on the front of the control panel.	A. Look for Touch screen to come on.	Machine works Yes--end troubleshooting No--go to Step B. next
Main Power Cord is not plugged in	B. Plug in main power cord	Machine works Yes--end troubleshooting No--go to Step C. next
Main 20 amp outlet circuit breaker has tripped	C. Check circuit breaker and reset if necessary. (Check wall outlet with a light to make sure it works)	Machine works Yes--end troubleshooting No--but a light works in outlet--go to Step D. next No--but light does not work in outlet. You must solve your power delivery problem independent of machine.
No 115 Volts AC power to (MAG)	D. Check for incoming power (MAG) for 115 Volts AC	(MAG) L1 black wire to L2 white wire 115 Volts AC Yes--go to Problem-Red E-stop screen displayed on touch screen, Next Page No--go to Step E. next
No power from junction box	E. At rear junction box (White box in back of grinder beside vacuum) Wire Block 2 (WB2) check for 115 Volts AC	(WB2) Across main power cord #02 white wire to #02 black wire for 115 Volts AC Yes--replace panel power cord #05 No--replace main power cord #02

ELECTRICAL TROUBLESHOOTING (Continued)

PROBLEM--Red E-Stop screen displayed on Touch Screen

In your Product Packet Assembly, there are a series of prints. Find the print titled 650-Wiring Diagram and Junction Box/Light Assembly, before starting the troubleshooting below. Verify all wires shown on that drawing are correct and pull on wire terminals with approximately 3 lbs force to verify there are no loose terminal connections and/or no loose crimps between wire and terminal. If loose terminals are found, retighten and retest system. If problem persists, test as listed below.

Possible Cause	Checkout Procedure	
You must push the green Push to Start Switch (PSS)	A. Listen for magnetic contactor (MAG) to pull in with a clunk.	Machine works Yes--end troubleshooting No--go to Step B. next
Pull red e-stop button out	B. Repeat push the green button (PSS) again.	Machine works Yes--end troubleshooting No--go to Step C. next
115V power not delivered to MAG coil	C. Check at Magnetic contactor coil for 115 Volts AC with main electrical power on and pushing (PSS)	(MAG) Term #A1 to A2 for 115 Volts AC Yes--replace magnetic starter No--go to Step D. next
Controller E-stop output relay on	D. Check on relay board (RT1) for light on for output "F" (farthest light to right)	Light is: Off-- Controller software corrupt or missing, contact factory. On-- go to step E. next
Controller E-stop relay no continuity	E. With the machine power on, Relay light on, measure across relay contacts.	(RT1) terminals F+ to F- for 115 Volts AC Yes-- Replace output relay F in (RT1) No-- go to step F. next
(PSS) Is bad	F. With the machine power on, measure across normally open contacts of (PSS)	(PSS) Term #3 to #4 for 115 Volts AC (PSS) not pushed, "0" Volts AC (PSS) pushed. No-- Replace (PSS) Yes-- go to step G. next
(ESS) Is bad	G. With the machine power on, measure across normally closed contacts of (ESS)	(ESS) Term #1 to #2 for "0" Volts (ESS) pulled out, 115 Volts AC (ESS) pressed in. No-- Replace (ESS) Yes-- go to step H. next
Bad wires	H. With the machine power off, verify continuity of wires and connections.	Measure continuity of wires #16, 29, 31, 32, 35, 37, 43, 49, and 27 from (LVR) term 6 to (MAG) L3. Replace any bad wires or repair loose connections.

ELECTRICAL TROUBLESHOOTING (Continued)

PROBLEM--Machine light is not working

Assuming AC main power cord wire #2 has 115 Volts AC at (WB2) Wire Block 2.

In your Product Packet Assembly, there are a series of prints. Find the print titled Junction Box and Light Assembly, before starting the troubleshooting below. Verify all wires shown on that drawing are correct and pull on wire terminals with approximately 3 lbs force to verify there are no loose terminal connections and/or loose crimps between wire and terminals. If loose terminals are found, tighten and retest system. If problem persists, test as listed below.

Possible Cause

Checkout Procedure

Light switches are not turned on or there is a bad bulb

A. Turn on machine light toggle switch on lamp holder. Check the light bulb in another light fixture or replace with a new bulb. Next turn on light switch electrical junction cover switch

Light works
Yes--end troubleshooting
No--go to Step **B.** next

Wire cord is bad

B. Remove cover of light junction box check for 115 Volts AC

Check for 115 Volts AC across light cord white wire #03 to switch black wire #03
Yes--go to Step **C.** next
No--replace light cord wire #03

Switch or machine light is bad

C. Check for 115 Volts AC across machine light assembly

Check for 115 Volts AC across machine black wire #10 to white wire #10
Yes--replace machine light assembly*
No--replace switch assembly

*NOTE: Again we want to remind, that there is a switch at the back of the machine light assembly, which must be turned on for the light to work.

ELECTRICAL TROUBLESHOOTING (Continued)

PROBLEM--Spin Drive not working in (manual) jog mode and in SPIN MODE.

Assuming 115 Volts AC to control panel and all other manual (jog) mode functions are working.

In your Product Packet Assembly, there are a series of prints. Find the print titled 650-Wiring Diagram before starting the troubleshooting below. Verify all wires shown on that drawing are correct and pull on wire terminals with approximately 3 lbs force to verify there are no loose terminal connections and/or loose crimps between wire and terminal. If loose terminals are found, tighten and retest system. If problem persists, test as listed below.

Possible Cause	Checkout Procedure	
Spin Speed Pot (SSP) set to zero	A. Set (SSP) to 200 on the control panel.	Spin Motor works Yes--end troubleshooting No--go to Step B. next
Spin Motor Switch not on on Touch Screen	B. Turn spin drive switch on (touch green area) from SPIN MANUAL screen.	Spin Motor works Yes--end troubleshooting No--go to Step C. next
Door is open	C. Alarm on screen should indicate that the door must be closed for the spin drive to operate. Close door.	Spin Motor works Yes--end troubleshooting No--go to step D. next
Circuit breaker 42 is tripped (4A)	D. Reset circuit breaker switch (Tripped by current overload) check that reel is free spinning	Spin Motor works Yes--end troubleshooting No--go to step E. next
Relay 9 (RT1) is not working	E. Check for (SDC) input of 115 Volts AC	(SDC) Term #L1 to #L2 for 115 Volts AC Yes--skip to step H. next No--go to Step F. next
Verify Light is on	F. Check (RT1) for light #9 to be on (Door must be closed and spin drive switch on)	Light is ON. Yes--go to Step G. next No--Contact factory
Verify Continuity of relay 9 in RT1	G. With light #9 on, Check (RT1) relay 9 for continuity.	(RT1) Term 9+ to term 9- for 115 Volts AC No--go to Step H. next Yes--Replace relay #9 in (RT1)
Relay 4 (RT1) is not working	H. With 115 Volts AC at Term L1 and L2, check (SDC) output. Have Spin speed pot (SSP) set at 400	(SDC) term A1 to term A2 measure approx 90 Volts DC Yes--Skip to Step L. No-- go to step I. Next
	I. With 115 Volts AC at Term L1 and L2, check (SDC) output. Have Relief Torque Pot (RTP) set to Red Line.	(SDC) term A1 to term A2 measure approx 12 Volts DC No-- Skip to step N. Yes-- go to step J. Next

ELECTRICAL TROUBLESHOOTING (Continued)

Possible Cause	Checkout Procedure	
	<p>J. Check (RT1) for light #4 to be on Insure that Spin Drive switch has been pressed on from SPIN MANUAL screen at least once</p>	<p>Light is: On-- go to Step K. next Off-- Contact factory</p>
Relay #4 is bad	<p>K. With light #4 on, verify continuity</p>	<p>(RT1) Term 4+ to term 4- for "0" Ohms Yes--Replace (SDC) No--replace Relay 4 (RT1)</p>
Reversing relay(s) bad (RT1)	<p>L. Measure voltage at spin motor</p>	<p>(RT1) Term A+ to term D+ should read the same 90 Volts DC measured at step H. Note polarity Yes--Skip to Step N. No-- go to Step M. next</p>
	<p>M. Reverse direction of spin motor from SPIN MANUAL touch screen</p>	<p>(RT1) Term A+ to term D+ should read the same 90 Volts DC measured at step H., but opposite polarity Yes--Skip to Step O. No-- Replace relays A, B, C, & D in (RT1)</p>
Spin Speed Pot (SSP) is not working	<p>N. (SSP) on Main Panel</p>	<p>(SDC) Black wire of (SSP)- H to Red wire of (SSP)-W Pot full CCW Pot Full CW 4.4 Volts DC 0 Volts DC (SDC) White wire of (SSP)- L to Red wire of (SSP)-W Pot full CCW Pot Full CW 0 Volts DC 4.4 Volts DC Yes-- Replace (SDC) No-- Replace (SSP)</p>
Spin Drive motor is bad	<p>O. With machine power off, Check spin motor continuity</p>	<p>At (RT1) Term A+ and B+ or C+ and D+ check approx. 0 ohms across the black and white wires Yes-- Replace (SDC) No--go to Step P. next</p>
Worn motor brushes	<p>P. Inspect motor brushes</p>	<p>Remove the brushes one at a time and maintain orientation for reinsertion. See if brush is worn short 3/8" [10mm] minimum length. Yes-- replace motor brushes No-- replace Spin Drive motor</p>

ELECTRICAL TROUBLESHOOTING (Continued)

PROBLEM--Spin Drive not working in (manual) jog mode and in RELIEF MODE.

Assuming 115 Volts AC to control panel and all other manual (jog) mode functions are working.

In your Product Packet Assembly, there are a series of prints. Find the print titled 650-Wiring Diagram before starting the troubleshooting below. Verify all wires shown on that drawing are correct and pull on wire terminals with approximately 3 lbs force to verify there are no loose terminal connections and/or loose crimps between wire and terminal. If loose terminals are found, tighten and retest system. If problem persists, test as listed below.

Possible Cause	Checkout Procedure	
Relief Torque Pot (RTP) set to zero	A. Set (SSP) to 20 on the control panel.	Spin Motor works Yes--end troubleshooting No--go to Step B. next
Spin Motor Switch not on on Touch Screen	B. Turn spin drive switch on (touch green area) from RELIEF MANUAL screen.	Spin Motor works Yes--end troubleshooting No--go to Step C. next
Door is open	C. Alarm on screen should indicate that the door must be closed for the spin drive to operate. Close door.	Spin Motor works Yes--end troubleshooting No--go to step D. next
Circuit breaker 42 is tripped (4A)	D. Reset circuit breaker switch (Tripped by current overload) check that reel is free spinning	Spin Motor works Yes--end troubleshooting No--go to step E. next
Relay 9 (RT1) is not working	E. Check for (SDC) input of 115 Volts AC	(SDC) Term #L1 to #L2 for 115 Volts AC Yes--skip to step H. next No--go to Step F. next
Verify Light is on	F. Check (RT1) for light #9 to be on (Door must be closed and spin drive switch on)	Light is On--go to Step G. next No--Contact factory
Verify Continuity of relay 9 in RT1	G. With light #9 on, Check (RT1) relay 9 for continuity.	(RT1) Term 9+ to term 9- for 115 Volts AC No--go to Step H. next Yes--Replace relay #9 in (RT1)
Relay 4 (RT1) is not working	H. With 115 Volts AC at Term L1 and L2, check (SDC) output. Have Relief Torque Pot (RTP) set at Red Line.	(SDC) term A1 to term A2 measure approx 12 Volts DC Yes--Skip to Step L. No-- go to step I. Next
	I. With 115 Volts AC at Term L1 and L2, check (SDC) output. Have Spin Speed Pot (SSP) set to 400	(SDC) term A1 to term A2 measure approx 90 Volts DC No-- Skip to step N. Yes-- go to step J. Next

ELECTRICAL TROUBLESHOOTING (Continued)

Possible Cause	Checkout Procedure	
Relay #4 is bad	<p>J. Check (RT1) for light #4 to be off Insure that Spin Drive switch has been pressed on from RELIEF MANUAL screen at least once</p>	<p>Light is: o r r . . g o o t o s t e p K. next On-- Contact factory</p>
Reversing relay(s) bad (RT1)	<p>K. With light #4 on, verify continuity</p> <p>L. Measure voltage at (RT1)</p> <p>M. Reverse direction of spin motor from SPIN MANUAL touch screen</p>	<p>(RT1) Term 4+ to term 4- for "0" Ohms Yes--Replace relay 4 (RT1) No--replace (SDS)</p> <p>(RT1) Term A+ to term D+ should read the same 12 Volts DC measured at step H. Note polarity Yes--Skip to Step M. No-- go to Step N. next</p> <p>(RT1) Term A+ to term D+ should read the same 12 Volts DC measured at step H., but opposite polarity Yes--Skip to Step O. No-- Replace relays A, B, C, & D in (RT1)</p>
Relief Torque Pot (RTP) is not working	<p>N. (RTP) on Main Panel</p>	<p>(SDC) Black wire of (RTP)- H to Red wire of (RTP)-W Pot full CCW Pot @ Red line .2 Volts DC .1 Volts DC (SDC) White wire of (RTP)- L to Red wire of (RTP)-W Pot full CCW Pot @ Red line .1 Volts DC .2 Volts DC Yes-- Replace (SDC) No-- Replace (SSP)</p>
Spin Drive motor is bad	<p>O. With machine power off, Check spin motor continuity</p>	<p>At (RT1) Term A+ and B+ or C+ and D+ check approx. 0 ohms across the black and white wires Yes-- Replace (SDC) No--go to Step P. next</p>
Worn motor brushes	<p>P. Inspect motor brushes</p>	<p>Remove the brushes one at a time and maintain orientation for reinsertion. See if brush is worn short 3/8" [10mm] minimum length. Yes-- replace motor brushes No-- replace Spin Drive motor</p>

ELECTRICAL TROUBLESHOOTING (Continued)

PROBLEM--Grinding motor not working in (manual) jog mode.

Assuming 115 Volts AC to control panel and all other manual (jog) mode functions are working.

In your Product Packet Assembly there are a series of prints. Find the print titled 650 - Wiring Diagram, before starting the troubleshooting below. Verify all wires shown in the drawing are correct and pull on wire terminals with approximately 3 lbs force to verify there are no loose terminal connections and/or loose crimps between wire and terminal. If loose terminals are found, tighten and retest system. If problem persists, test as listed below.

Possible Cause	Checkout Procedure	
Grinding Motor Switch (GMC) is not on	A. Turn switch on from either SPIN MANUAL screen or RELIEF MANUAL screen	Grinding Motor works Yes--end troubleshooting No--go to Step B. next
Circuit Breaker (CB28) 10A is tripped	B. Reset circuit breaker switch (tripped by current overload)	Grinding Motor works Yes--end troubleshooting No--go to step C. next
(GMC) is not working	C. Check for (GMC) incoming 115 Volts AC	(GMC) Term #L1 to #L2 for 115 Volts AC Yes--go to step D. next No--go to Step E. next
	D. Check for (GMC) output voltage of 95 Volts DC	(GMC) Term A+ to A- for 95 +/- 3 Volts DC Yes-- go to Step K. ** No--if 0 V replace (GMC)
Relay (RE112) is not working	E. Check for (RE112) input of 24 Volts DC at the coil. Reminder, Grind Drive switch must be on and doors must be closed.	(RE112) Term 0 to term 1 for 24 Volts DC Yes--If 24 Volts DC go to Step F. next No--Skip to Step H.
Relay (RE112) Contacts bad	F. Check for (RE112) input of 115 Volts AC	(RE112) Term 8 (black wire No. 40) to Term 4 (white wire No. 63) for 115 Volts AC Yes--Go to step G. next No--Check continuity of wires 40 and 63. if bad, replace bad wire.
	G. Check for (RE112) output of 115 Volts AC	(RE112) Term 6 (black wire No. 102) to Term 2 (white wire No. 61) for 115 Volts AC Yes--Check continuity of wires 102 and 61. if bad, replace bad wire. No--replace (RE112)

ELECTRICAL TROUBLESHOOTING (Continued)

Possible Cause	Checkout Procedure	
Relay 5 (RT1) is not working	<p>H. (RT1) check that the light is on for relay 5, make sure grind drive switch is on</p> <p>I. Light is on for Relay 5, check continuity</p>	<p>Light is: On-- Go to Step I. next Off--Contact Factory</p> <p>(RT1) Term 5+ to 5-, measure DC voltage 0 Volts DC-- Replace wires #51 and #52 24 Volts DC-- Replace relay 5 (RT1)</p>
Grinding Head DC Motor cord is bad (remove back cover to motor)	K. Check grinding motor cord #01	<p>At DC motor check term #A1 to #A2 for 95 Volts DC Yes--go to Step L. next No--replace grinding motor cord #1</p>
Grinding Motor is bad	L. Check grinding motor continuity	<p>Remove wires at terminal A1 and A2 at motor. Check for 0 ohms across terminals A1 and A2. Yes--end troubleshooting No--go to Step M. next</p>
Worn Motor Brushes	M. Inspect Motor Brushes	<p>Remove the brushes one at a time and maintain orientation for reinsertion. See if brush is worn short 9/16" [14 mm] minimum length. Yes--replace motor brushes. No--replace Spin Drive Motor</p>

****NOTE:** If voltage checks less than 95 VDC, but not 0 VDC, then adjust MAX SPEED POT on the (GMC) until you read 95 VDC. If you cannot achieve 95 VDC, replace the (GMC).

ELECTRICAL TROUBLESHOOTING (Continued)

PROBLEM--Dust Collector not working in (manual) jog mode.

Assuming 115 Volts AC to control panel and all other manual (jog) mode functions are working.

In your Product Packet Assembly, there are a series of prints. Find the print titled **650-Wiring Diagram** and **Junction Box and Light Assembly** before starting the troubleshooting below. Verify all wires shown on that drawing are correct and pull on wire terminals with approximately 3 lbs force to verify there are no loose terminal connections and/or no loose crimps between wire and terminal. If loose terminals are found, tighten and retest system. If problems persists, test as listed below.

Possible Cause	Checkout Procedure	
Dust Collector Switch (Vacuum) is not on	A. Turn switch on from SPIN MANUAL or RELIEF MANUAL screen	Dust Collector works-- Yes--end troubleshooting No--go to Step B. next
Circuit Breaker 6 (CB6) is tripped (10 amp) (See rear junction box)	B. Reset circuit breaker switch (tripped by current overload)	Dust Collector works-- Yes--end troubleshooting No--go to step C. next
(RT1) relay E is not working	C. With Vacuum switch on, Check for (RT1) Relay E on	Light is on: Yes--go to step D. next No--Contact Factory
	D. (RT1) Relay E verify continuity	(RT1) Term #E+ to #E- for 115 Volts AC Yes--replace Relay E (RT1) No--go to Step E. next
Circuit Breaker 2 (CB2) is not working (4 amp)	E. Check for (CB2) normally closed contacts	(WB1) Wire Block 1 (white wire) #78 to (CB2) (black wire) #58 for 115 Volts AC Yes--replace (CB2) and wire #70 No--replace wire #58
Relay 34 (RE34) is not working	F. Check for (RE34) input of 115 Volts AC at coil. (This relay is located in rear junction box.)	(RE34) Term 0 to term 1 for 115 Volts AC Yes-- go to Step G. next No--replace VAC relay cord #4
	G. Check for (RE34) input of 115 Volts AC at contacts	(RE34) Term 8 to term 4 for 115 Volts AC Yes--go to Step H. next No--go the step I. next
	H. Check for (RE34) output of 115 Volts AC at contacts	(RE34) Term 6 to term 2 for 115 Volts AC Yes--replace vacuum motor No--replace (RE34)
(CB6) is not working (10 amp)	I. Check for (CB6) normally closed contacts	(WB2) Wire Block 1 (white wire) #48 to (CB6) (black wire) #46 for 115 Volts AC Yes--replace (CB6)and wire #46 No--replace wire #48

ELECTRICAL TROUBLESHOOTING (Continued)

PROBLEM--Winch does not work in either direction.

In your Product Packet Assembly, there are a series of prints. Find the print titled Junction Box and Light Assembly before starting the troubleshooting below. Verify all wires shown on that drawing are correct and pull on wire terminals with approximately 3 lbs force to verify there are no loose terminal connections and/or loose crimps between wire and terminal. If loose terminals are found, tighten and retest system. If problem persists, test as listed below.

Possible Cause	Checkout Procedure	
7 amp circuit breaker on winch motor is tripped	A. Reason: Check for a lifting overload condition or wiring shorted to ground. Reset breaker located at end of winch motor.	Winch works-- Yes--end troubleshooting No--go to Step B. next
No voltage to motor	B. Check that motor coil cord from DC motor is plugged in	Winch works-- Yes--end troubleshooting No--go to Step C. next
	C. Check for 115 Volts AC at the plug end winch cord wire #6 by plugging in a hand drill	Drill works-- Yes--replace winch No-- go to Step D. next
	D. Check for main power cord #2 is plugged in to outlet	Winch works-- Yes--end troubleshooting No--go to Step E. next
	E. Check connections inside rear junction box on (WB2) Wire Block 2 from main power cord.	(WB2) 115 Volts AC check black side to white side wires Yes--replace cord #6 No--replace cord #2

ELECTRICAL TROUBLESHOOTING (Continued)

PROBLEM--Traverse Drive not working in (manual) jog mode

Assuming 115 Volts AC to control panel and all other manual (jog) mode functions are working.

In your Product Packet Assembly, there are a series of prints. Find the print titled 650-Wiring Diagram, before starting the troubleshooting below. Verify all wires shown on that drawing are correct and pull on wire terminals with approximately 3 lbs force to verify there are no loose terminal connections and/or loose crimps between wire and terminal. If loose terminals are found, tighten and retest system. If problem persists, test as listed below.

Possible Cause	Checkout Procedure	
Traverse Speed Pot (TSP) set to zero	A. Set (TSP) to 35 on the control panel	Traverse works Yes--end troubleshooting No--go to step B. next
Traverse Actuator release lever released	B. Insure release lever is in proper position	Traverse works Yes--end troubleshooting No--go to Step C. next
Circuit Breaker 32 (CB32) (2 amp) tripped out	C. Too heavy a grind causes grinding head traverse motor to overload and trip the circuit breaker. Reset (CB32)	Traverse works Yes--end troubleshooting No--go to Step D. next
Traverse Drive Control (TDC) do not have power	D. Check for 115 Volts AC incoming to (TDC) (insure traverse right or left has been pressed at least once)	On (TDC) Term L1 to L2 for 115 Volts AC Yes--Skip to Step H. No--go to Step E. next
Relay 8 (RT1) is bad	E. Check for relay 8 (RT1) light on (insure traverse right or left has been pressed at least once)	Light is: On-- go to Step F. next Off-- Contact Factory
	F. Check relay 8 for continuity Insure relay 8 light is on	(RT1) Term 8+ to 8- read 115 Volts AC Yes-- Replace Relay 8 (RT1) No-- go to Step G. next
Circuit Breaker 32 (CB32) bad	G. Check CB32 for voltage	(CB32) from Line neutral (White wire at the line filter wire # N11-34FTR8-FH to wire # 32-36CB32-BL at CB32 measure 115 Volts AC: No-- Replace CB32 Yes-- Verify continuity of wire #25. Replace or repair bad wire(s)

ELECTRICAL TROUBLESHOOTING (Continued)

Possible Cause	Checkout Procedure	
No DC Voltage from (TDC) Traverse Drive Control	<p>H. Check for 49 Volts DC across (TDC) terminals A1 to A2 this voltage drives the DC traverse motor. NOTE: Traverse must be on and have (TSP) turned full CW to maximum voltage of 49 VDC</p>	<p>Check (TDC) terminals A1 to A2 for 49 Volts DC Yes--go to step I. next No--go to Step J. next</p>
Traverse Motor is bad	<p>I. Check traverse motor continuity</p>	<p>Remove wires from terminals A1 & A2 0 ohms across the black and white wires Yes--go to Step J. next No--go to Step N.</p>
Check Relays 2 and 3	<p>J. (RT1) Verify that relay 2 light comes on when Traverse Right is pressed, and that relay 3 light comes on when Traverse Left is pressed</p>	<p>Lights come: On-- go to step K. next Off-- Skip to step L.</p>
(TSP) (10K) is bad	<p>K. Check (TSP) for 10,000 ohms Remove three wires from (TDC) red from term S2 white from term S0 black from inline connector (Wire 39)</p>	<p>Check for 10,000 ohms red to white wires Full CCW--0 ohms Full CW--10,000 ohms Red to black wires Full CCW--10,000 ohms Full CW--0 ohms Yes--go to Step L. next No--replace (TSP)</p>
Gap between flag and prox is incorrect.	<p>L. Gap between flag and Prox should be 3/16" to 1/4" [4-6mm]. Prox light does not light when flag is under prox.</p>	<p>If incorrect, adjust per adjustment section of manual. Traverse works-- Yes-- End troubleshooting No-- go to step M. next</p>
Proximity switch is bad	<p>M. From the Touch screen, Enter "HELP" screen from main menu.</p>	<p>Follow instructions on screen to verify traverse proximity switches are ok. Switch is Good-- Replace (TDC) Bad-- Replace switch</p>
Worn motor brushes	<p>N. Inspect Motor Brushes</p>	<p>Remove the brushes one at a time and maintain orientation for reinsertion. See if brush is worn short, 3/8" [10 mm] minimum length. Yes--replace motor brushes No--replace Traverse Drive Motor</p>

ELECTRICAL TROUBLESHOOTING (Continued)

PROBLEM--Stepper Infeed not working in (manual) jog mode.

Assuming 115 Volts AC to control panel and all other manual (jog) mode functions are working.

In your Product Packet Assembly, there are a series of prints. Find the print titled 650-Wiring Diagram before starting the troubleshooting below. Verify all wires shown on that drawing are correct and pull on wire terminals with approximately 3 lbs force all terminals to verify there are no loose terminal connections and/or loose crimps between wire and terminal. If loose terminals are found, tighten and retest system. If problem persists, test as listed below.

Possible Cause	Checkout Procedure	
Infeed Jog Switch is not held to on position	A. Hold switch on in either direction	Stepper motor works Yes--end troubleshooting No--go to Step B. next
Actuator is at physical limit	B. Move stepper in opposite direction	Stepper Motor works Yes--end troubleshooting No--go to step C. next
Circuit Breaker 3 (CB3) is tripped (2 amp)	C. Reset circuit breaker switch (tripped by current overload) Grinding head stepper infeed mechanism jammed causing overload	Stepper Motor works Yes--end troubleshooting No--go to step D. next
High Low Switch is not on high speed	D. Put switch on high speed (rabbit) for ease of checkout of Stepper Infeed Control (SIC)	High speed works Yes--end troubleshooting No--go to Step E. next
Stepper motor drive coupling is loose	E. You can feel stepper pulses on motor when (HLS) is on high or low & (IJS) switch is depressed in either up or down direction. Open stepper infeed inspection plate to check for loose coupling. Retighten coupling to drive actuator screw. See adjustment section of manual.	Stepper works-- Yes--end troubleshooting No--go to Step F. next
No DC voltage to Stepper Infeed Control (SIC)	F. (SIC) Check for 24 Volts DC Power in	(SIC) Term GND to V+ measure 24 Volts DC Yes-- go to step G. next No-- Skip to step H.
No DC Voltage to OPTO terminal of (SIC)	G. (SIC) Check voltage at OPTO terminal	(SIC) Term GND to OPTO measure 24 Volts DC Yes-- go to step I. No-- Replace wire #50 (with resistor)

ELECTRICAL TROUBLESHOOTING (Continued)

Possible Cause	Checkout Procedure	
Mag contact or wire bad	H. Measure voltage at (MAG) insure power is on, and green (PSS) has been pressed.	(MAG) term 13 to 14, Measure 0 volts DC Yes--Replace wire #46 No--Replace (MAG)
No Step pulse from PLC	I. Check light Y0 on PLC. While pressing up or down it should light (pressing down Y1 will also light)	Light comes on: Yes-- go to step H. next No-- Contact Factory
Stepper Infeed Control (SIC) Wiring bad	J. Check wiring at (SIC).	Insure all wires are connected at the (SIC) to the connectors and that none have become loose. Some connections have multiple wires in them, be sure all are tight by gently "tugging" on them. If all wires appear to be connected and correct, proceed:
Stepper Infeed Control (SIC) or Stepper motor is bad	K. Check output at (SIC). Have High/Low Switch set on high speed (rabbit)	(SIC) Terminal phase A to terminal phase A' Measure 4.7 Volts DC, 0.2-0.3 Volts while jog button is pressed. (SIC) Terminal phase B to terminal phase B' Measure 4.7 Volts DC, 0.2-0.3 Volts while jog button is pressed. Yes--replace stepper motor No--replace (SIC)

ELECTRICAL TROUBLESHOOTING (Continued)

PROBLEM--No Manual (jog) cycle or Auto Cycle stops because of a system error message on Touch Screen.

System Error Message	Checkout Procedure	Message Status
STORE FINGER FOR SPIN GRIND	A. Rotate index finger assembly to spin position	Clears--Proceed to next system error message you have or continue running. Remains--go to Step B. next
	B. Check (PLC) input from Finger Stored/Down prox	From "Help" Screen verify Finger Stored/Down prox input is on (Red) Follow instructions on screen.
ROTATE HEAD DOWN FOR SPIN GRIND	A. Rotate grind head assmby down	Clears--Proceed to next system error message you have or Continue running. Remains--go to Step B. next
	B. Check (PLC) input from Head in Relief Pos. (Position) prox	From "Help" Screen verify Head in Relief Pos. prox input is working. Follow instructions on screen.
HOME TRAVERSE (TO RIGHT PROX) TO START	A. Jog Grind head to right prox with touch screen controls	Clears--Proceed to next system error message you have or Continue running. Remains--go to Step B. next
	B. Check (PLC) input from Right Traverse prox switch	From "Help" Screen verify Right Traverse Prox input is working. Follow instructions on screen.
ROTATE HEAD UP FOR RELIEF GRIND	A. Rotate grind head assmby up	Clears--Proceed to next system error message you have or Continue running. Remains--go to Step B. next
	B. Check (PLC) input from Head in Relief Pos. prox	From "Help" Screen verify Head in Relief Pos. prox input is working. Follow instructions on screen.

ELECTRICAL TROUBLESHOOTING (Continued)

System Error Message	Checkout Procedure	Message Status
RELEASE FINGER FOR RELIEF	<p>A. Release finger. Make sure that the finger is allowed to come forward at least once.</p> <p>B. Check (PLC) input from Door Saftey Switch</p>	<p>Clears--Proceed to next system error message you have or continue running. Remains--go to Step B. next</p> <p>From "Help" Screen verify Finger Stored / Down prox input is working. Follow instructions on screen.</p>
ENTER NUMBER OF BLADES	<p>A. Blade count is required to run Relief grind. Count blades and enter the number under the Blade # Field.</p>	<p>Clears--Proceed to next system error message you have or continue running.</p>
LOW VOLTAGE DETECTED	<p>A. Input line voltage has dropped below 100V. Plug machine into a better source of power. See Power requirements at front of manual.</p>	<p>Clears--Proceed to next system error message you have or continue running.</p>
DOOR MUST BE CLOSED TO OPERATE	<p>A. For safety reasons, door must be closed to operate spin and / or grind motors. Close and latch door.</p> <p>B. Check (PLC) input from Door Saftey Switch</p>	<p>Clears--Proceed to next system error message you have or continue running. Remains--go to Step B. next</p> <p>From "Help" Screen verify Head in Relief Pos. prox input is working. Follow instructions on screen.</p>
INCREASE TORQUE KNOB SETTING	<p>A. An excessive amount of time has passed between blade indexes or at the start of a relief cycle. Increase the Relief Torque Pot.</p>	<p>Clears--Proceed to next system error message you have or continue running.</p>
TORQUE KNOB LOW OR DIRECTION WRONG	<p>A. An excessive amount of time has passed at the beginning of a Relief grind cycle before the finger down prox was detected. Verify Torque pot setting and / or spin direction. Reminder: Blade should push finger down.</p>	<p>Clears--Proceed to next system error message you have or continue running.</p>

ELECTRICAL TROUBLESHOOTING (Continued)

PROBLEM--No Manual (jog) cycle or Auto Cycle stops because of a system error message on Touch Screen (Continued)

System Error Message	Checkout Procedure	Message Status
FINGER NOT RELEASED, CHECK LH PROX POS (POSITION)	<p>A. During a relief grind cycle, the PLC did not see the finger released at the left prox position. Verify that the setting of the left traverse prox allows the finger to come off the blade.</p> <p>B. Check (PLC) input from Finger Stored/Down prox</p>	<p>Clears--Proceed to next system error message you have or continue running.</p> <p>Remains--go to Step B. next</p> <p>From "Help" Screen verify Finger Stored/Down prox input is Working. Follow instructions on screen.</p>
MOVE NOT POSSIBLE IN PAUSE MODE	<p>A. Press "Resume" on touch screen to finish current cycle.</p>	<p>Clears--Proceed to next system error message you have or Continue running.</p>
MACHINE IS IN PAUSE MODE, PRESS RESUME	<p>A. Machine was left in pause mode after last cycle. Press "resume" on touch screen.</p>	<p>Clears--Proceed to next system error message you have or Continue running.</p>
DOOR OPENED WHILE GRIND AND / OR SPIN ON	<p>A. Door was opened while potentially dangerous operations were still on. Turn off motors, pause, or finish cycle before opening doors.</p>	<p>Clears--Proceed to next system error message you have or Continue running.</p>
INCREASE TRAVERSE KNOB SETTING	<p>A. An excessive amount of time has passed at the beginning of an auto cycle before the grind head assy. has moved. Increase Traverse Speed pot or check that carriage is not released.</p>	<p>Clears--Proceed to next system error message you have or Continue running.</p>
TRAVERSE TIMEOUT, CHECK POT OR SETUP	<p>A. An excessive amount of time has passed during a traverse cycle. Increase Traverse Speed pot or verify that carriage assembly is not released or hitting an obstruction.</p>	<p>Clears--Proceed to next system error message you have or Continue running.</p>

ELECTRICAL TROUBLESHOOTING (Continued)

System Error Message	Checkout Procedure	Message Status
ACCEPT VALUES BEFORE RUNNING	A. Before an auto cycle can be started, verify the values in the displayed boxes and accept them by pressing the "Accept Values" button on the touch screen.	Clears--Proceed to next system error message you have or continue running.
OPEN DOOR TO RESET LIGHT	A. Before an auto cycle can be started, the last cycle completed must be cleared. Open the door or press the "Cycle Complete" button on the main screen to reset.	Clears--Proceed to next system error message you have or continue running.

ELECTRICAL TROUBLESHOOTING (Continued)

PROBLEM--Flasher light does not turn on at end of automatic cycle.

In your Product Packet Assembly, there are a series of prints. Find the print titled 650-Wiring Diagram, before starting the troubleshooting below. Verify all wires shown on that drawing are correct and pull on wire terminals with approximately 3 lbs force to verify there are no loose terminals. If loose terminals are found, tighten and retest system. If problem persists, test as listed below.

Possible Cause	Checkout Procedure	
Bulb is burned out	A. Remove bulb and test continuity	Bulb- Measure approx 300 Ohms Yes--go to Step B. next No--Replace bulb
Flasher (FLR) is bad	B. (FLR) Unplug flasher at terminal (RT1) 7+ and touch lead to black wire at (RT1) 7-	Light works: Yes--go to step C. next No-- Replace Flasher Assy.
No 115 Volts AC to flasher	C. After a cycle has completed, measure voltage to Flasher.	(RT1) Term. 7+ to (TB2) Measure 115 Volts AC Yes-- Replace Cord #06 No-- go to step D. next
Relay 7 (RT1) is bad	D. After a cycle has completed, check (RT1) for light 7 to be on	Light is on: Yes-- go to step E. next No-- Contact Factory
	E. Check continuity of relay 7	(RT1) Term 7+ to 7- Measure 115 Volts AC Yes-- Replace Relay 7 (RT1) No-- go to step F. next
Wire is bad	F. Measure voltage at relay	(RT1) Term 7- to (TB2) Measure 115 Volts Yes--Replace Cord #06 No-- Replace wire #36

-This page was left blank intentionally for note taking purposes-

MECHANICAL TROUBLESHOOTING

PROBLEM--Actuator drive shaft whipping excessively at high traverse speed.

Possible Cause

Bearings were bolted down tightly with bearings putting a bow into the drive shaft.

Checkout Procedure

Loosen bearing blocks and check squareness of bearing collar face 90 degrees to carriage rods with a square and tighten down. The drive shaft to carriage front shaft is 2.875 +/- .010" [73 +/- .3 mm] apart. See adjustment section for more information.

PROBLEM--Reels ground have high/low blades.

Traverse Speed set to fast.

Check roundness using a magnetic base dial indicator. Traverse speed should be set approximately 12 ft/min [4 meters/min] if roundness is varying.

Lineal bearings for the grinding head carriage are out of adjustment (loose) or have grit buildup causing uneven traversing load.

Relubricate and adjust linear bearings per adjustment section. If problem persists, replace lineal bearings on the carriage base. Check for any holes in the bellows that would permit any grinding grit penetration. See adjustment section for lineal bearing replacement.

PROBLEM--Excessive grinding stock being removed when traversing to the right in the relief grinding mode.

Gib adjustment for the relief finger assembly is loose so reel finger has movement. When traversing to the right minimum grinding stock removal should be seen as compared with heavy stock removal when traversing to the left.

Tighten the set screws for the gib adjustment. See procedure in the adjustment section in the manual.

PROBLEM--Grinding stock removal from reel is irregular during spin grinding.

Lineal bearings on the grinding head carriage are too loose.

The lineal bearing must be preloaded to the traverse shafts with no vertical movement. See manual adjustment section for carriage linear bearing adjustments.

PROBLEM--Carriage traversing varies speed while grinding.

Oil on carriage drive shaft.

Wipe oil completely from the traverse shaft. Spray down with a spray lubricant (do not use a teflon based lubricant) and wipe off completely.

Lineal bearings in the carriage do not rotate freely.

Check for grinding grit getting into the lineal bearings and cause excessive driving torque of carriage. Abrasive noise is detectable when excessive grit is in the lineal bearings. Replace the four lineal bearings in the main carriage. Check bellows for holes and replace if necessary.

Actuator bearings are not rotating freely.

Check bearings for free rotation or flat spots on the bearing outside diameter. Replace the six bearings if necessary. See adjustment section for bearing replacement.

MECHANICAL TROUBLESHOOTING (Continued)

PROBLEM--Too heavy a burr on cutting edge of reel blades.

Possible Cause

Traverse speed set to high causing a heavy burr on the reel blade when spin grinding.

Checkout Procedure

Traverse speed should be set lower approximately 12 ft/min. [4 meters/min.] for a smaller burr on cutting edge.

PROBLEM--Cone shaped reel after grinding.

Grinding head travel not parallel to the reel center shaft.

Grinding head travel was not setup parallel to the reel center shaft in vertical and horizontal planes. See Align the Reel Section in Operator's Manual.

PROBLEM--Relief grind on the reel blades do not go the full length of the reel.

The right side corner of the grinding wheel is always to be in contact with the reel blade. This is high point of the relief finger.

The right hand side of the grinding wheel is not in full contact for relief grinding. See Operator's Manual for NORMAL HELIX AND REVERSE HELIX for information of dressing the grinding wheel.

PARTS LIST

6509522 MAIN BASE ASSEMBLY

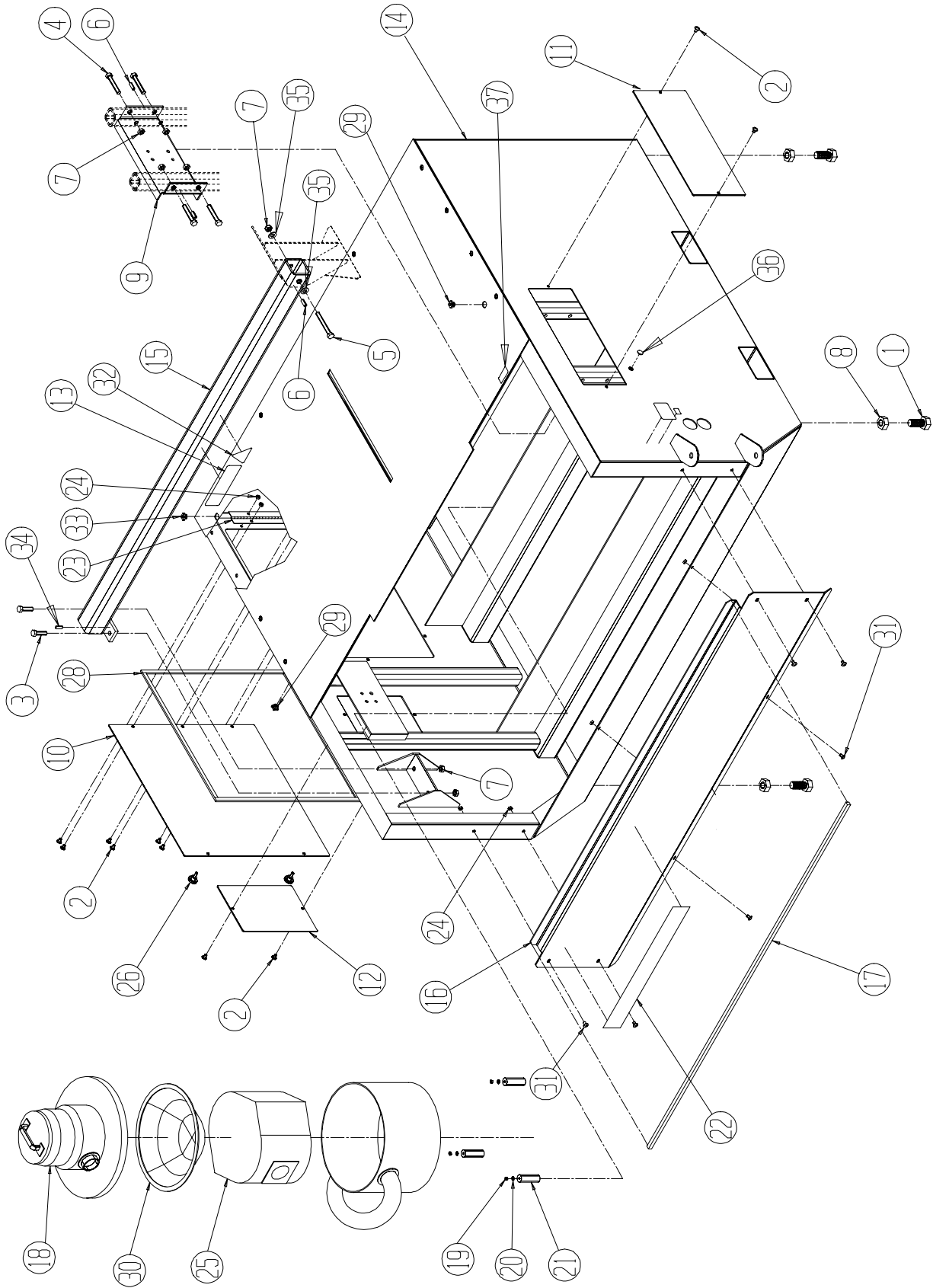

PARTS LIST (Continued)**6509522 MAIN BASE ASSEMBLY**

DIAGRAM NO.	PART NO.	DESCRIPTION
1	A993201	Hex Head Cap Screw 1-8 x 2
2	B310813	Button Head Socket Cap Screw 5/16-18 x 1/2
3	B502801	Hex Head Cap Screw 1/2-13 x 1 3/4
4	B504801	Hex Head Cap Screw 1/2-13 x 3
5	B506801	Hex Head Cap Screw 1/2-13 x 4 1/4
6	H371602	Roll Pin 3/8 Dia. x 1.00 Long
7	J507100	1/2-13 Locknut
8	J992000	1-8 Hex Jam Nut
9	6509035	Mounting Frame Adjuster
10	6509038	Large Access Panel - Left Hand
11	6509039	Access Panel - Right Hand
12	6509040	Small Access Panel - Left Hand
13	6509116	Fuel Warning Decal
14	6509505	Main Frame Base Weldment
15	6509510	Tooling Bar Weldment
16	6509069	Removable Front Panel
17	3708379	Foam Strip
18	6509337	Vacuum Assembly
19	J257100	1/4-20 Locknut
20	K250101	1/4 Flatwasher
21	6509163	Tube - Rubber Vacuum Mounting
22	6509074	ACCU-Master Decal
23	6509300	Hinge
24	J317000	5/16-18 Lock Nut
25	3708428	Vac Bag
26	3709756	Knob
28	3708378	Foam Strip .25 Thick
29	3707294	Heyco Bushing
30	3708437	Vacuum Cloth Filter
31	B311413	Button Head Cap Screw 5/16-18 x 7/8
32	3708612	Warning Decal Fuel, Symbol
33	3707273	Strain Relief
34	H372002	Roll Pin 3/8 Dia. x 1.25 Long
35	K500001	1/2 Flat Washer SAE
36	3708542	5/8 Hole Plug
37	6309111	Up/Down Decal

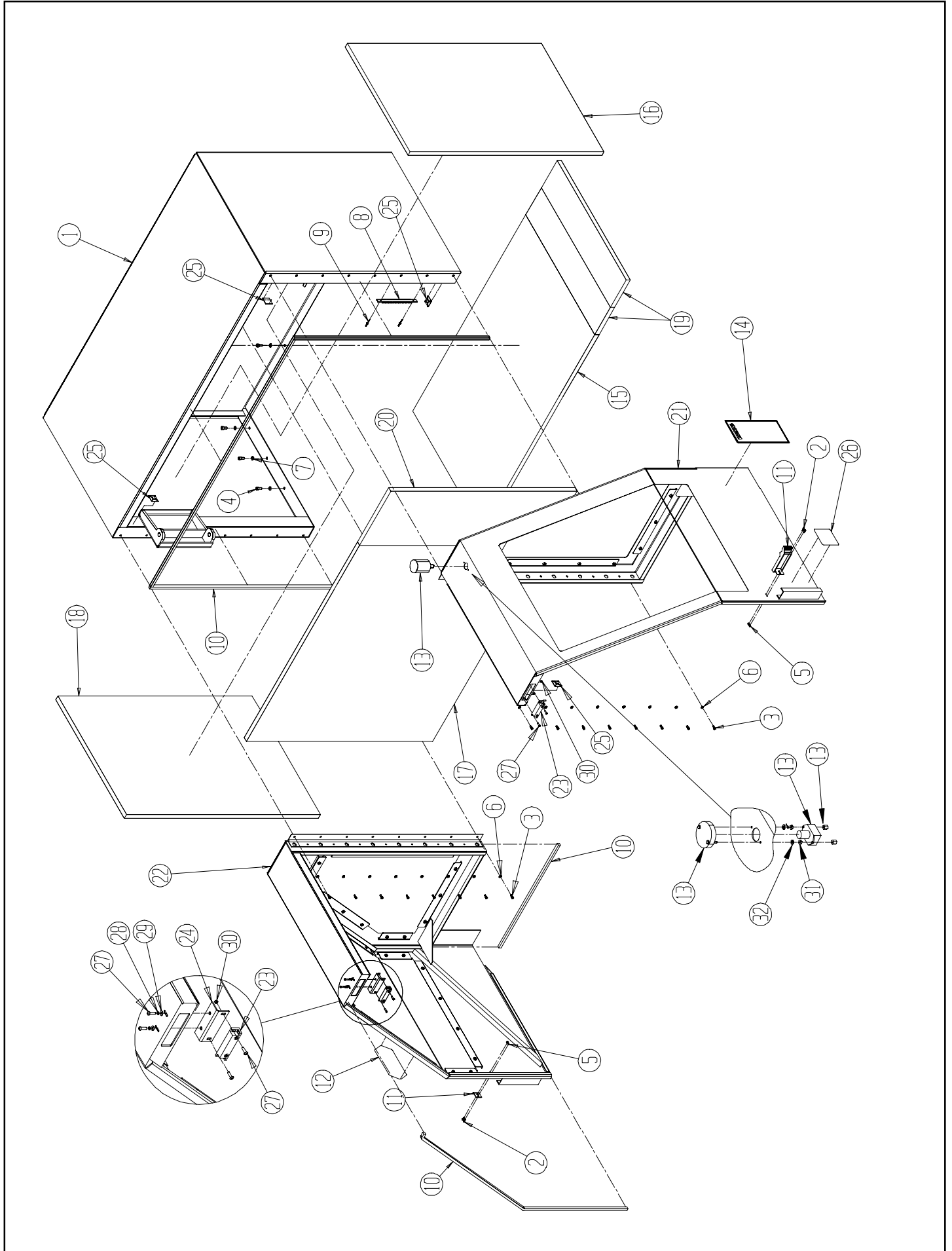

PARTS LIST (Continued)**6509440 CANOPY ASSEMBLY**

<u>DIAGRAM NO.</u>	<u>PART NO.</u>	<u>DESCRIPTION</u>
1	6509541	Canopy Frame Weldment
2	B190811	Socket Head Cap Screw 10 - 24 x 1/2
3	B310813	Socket Head cap Screw 5/16 -18
4	B371211	Socket Head Cap Screw 3/8 - 16 x 3/4
5	J197100	10 - 24 Locknut
6	K310001	5/16 Flatwasher
7	K371501	3/8 Split Lockwasher
8	3708205	Socket Holder
9	3708465	Blind Rivet
10	3708379	Foam Strip - .50 Thick
11	3708416	Soft Latch
12	3709990	Decal
13	6509411	Amber light 120 VAC
14	6509176	Warning Decal
15	6509217	Large Top Foam Pad
16	6509218	Foam Pad - Left Hand
17	6509219	Large Back Foam Pad
18	6509259	Foam Pad - Right Hand
19	6509260	Small Top Foam Pad
20	6509261	Small Back Foam Pad
21	6509437	Canopy Door Assembly - Right Hand
22	6509439	Canopy Door Assembly - Left Hand
23	6509441	Door Safety Switch Assembly
24	6509435	Door Safety Switch Bracket
25	3707224	Cable Tie Holder-Typical used throughout machine
26	3708703	Decal - Warning Safety
27	3708820	#8-32 x .50 Long Tamper Proof Screw
28	K161501	#8 Lockwasher
29	K160001	#8 Flat washer
30	J167000	#8-32 Jam Locknut
31	R000558	#8-32 Kep Nut
32	R000480	#8 Lockwasher w/teeth

PARTS LIST

6509437 - RIGHT HAND CANOPY DOOR

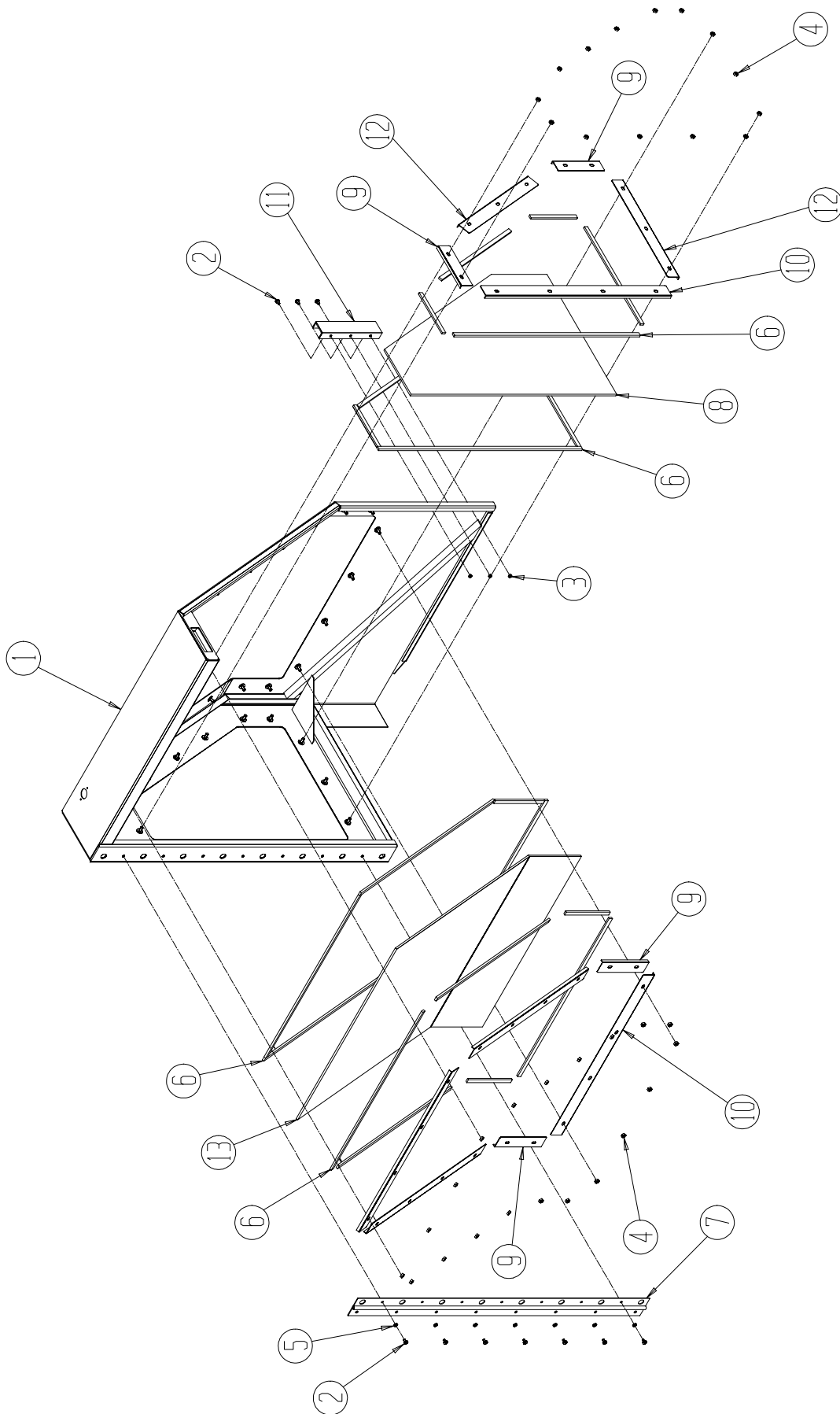

PARTS LIST (Continued)**6509437 - RIGHT HAND CANOPY DOOR**

<u>DIAGRAM NO.</u>	<u>PART NO.</u>	<u>DESCRIPTION</u>
1	6509436	Canopy Door Weldment - Right Hand
2	B250816	Button Head Socket Cap Screw 1/4-20 x 1/2
3	J257100	1/4-20 Locknut
4	J311000	5/16-18 Hex nut
5	K250001	1/4 Flatwasher
6	3708378	Foam Strip .25 Thick
7	6509099	Canopy Door Hinge
8	6509105	Canopy Door Side Window
9	6509111	Short Retaining Window Bracket
10	6509110	Long Retaining Window Bracket
11	6509112	Handle
12	6509182	Medium Retaining Window Bracket
13	6509104	Canopy Door Front Window

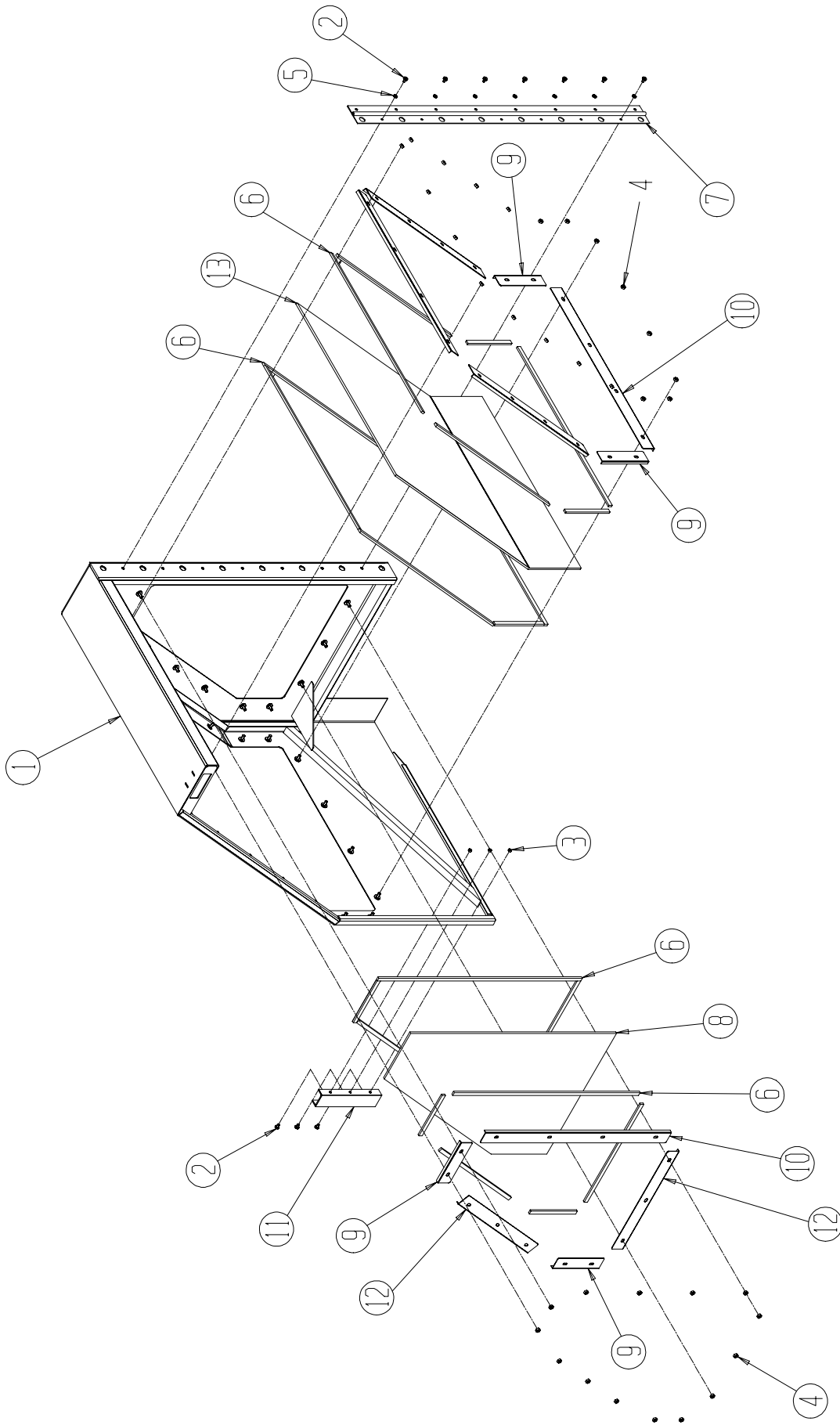

PARTS LIST (Continued)**6509439 CANOPY LEFT HAND DOOR****DIAGRAM****NO.****PART NO.****DESCRIPTION**

1	6509438	Canopy Door Weldment - Left Hand
2	B250816	Button Head Socket Cap Screw 1/4-2 1/2
3	J257100	1/4-20 Locknut
4	J311000	5/16-18 Hex nut
5	K250001	1/4 Flatwasher
6	3708378	Foam Strip .25 Thick
7	6509099	Canopy Door Hinge
8	6509105	Canopy Door Side Window
9	6509111	Short Retaining Window Bracket
10	6509110	Long Retaining Window Bracket
11	6509112	Handle
12	6509182	Medium Retaining Window Bracket
13	6509104	Canopy Door Front Window

PARTS LIST

6509526 WINCH AND BOOM ASSEMBLY

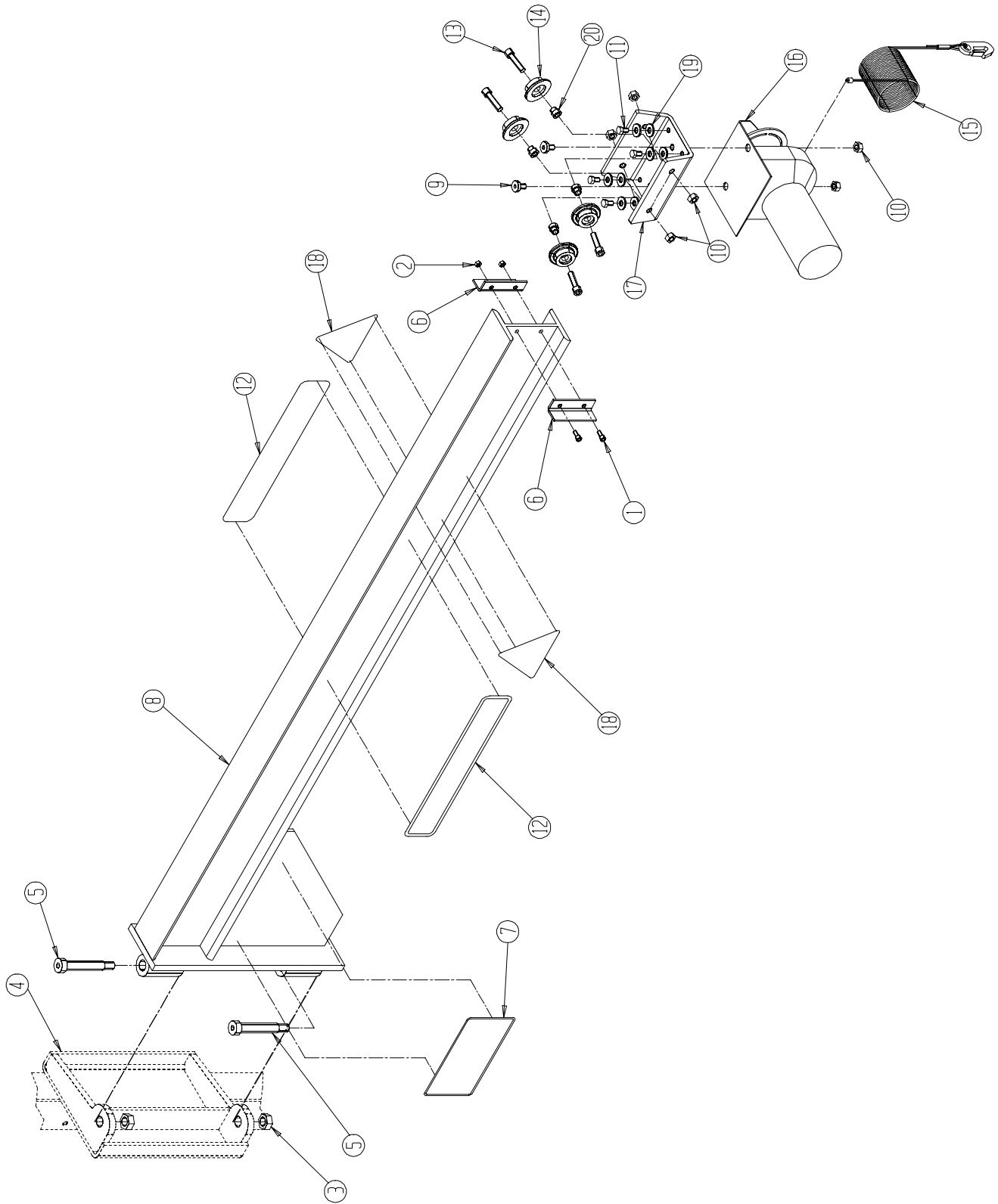

PARTS LIST (Continued)**6509526 WINCH AND BOOM ASSEMBLY**

DIAGRAM NO.	PART. NO.	DESCRIPTION
1	B251611	Socket Head Cap Screw 1/4-20 x 1 Long
2	J257100	1/4-20 Nylok Locknut
3	J627100	5/8-11 Locknut
4	6509541	Canopy Frame Weldment
5	3708398	Shoulder Bolt, .75 Dia. x 3.5 Long
6	6509103	Trolley stop Bracket
7	6509115	Winch Warning Decal
8	6509544	Boom Weldment
9	B371616	Button Head Socket Cap Screw 3/8-16 x 1" Long
10	J377100	3/8-16 Hex Jam Nylok Locknut
11	3708519	5/16-18 x 1/2 Nylon HHCS
12	6509298	Decal - Boom Cap
13	B372411	3/8-16 x 1.50 SHCS
14	6509367	Trolley Wheel Assy
15	6509594	Hook and Cable Assembly
16	6509546	Electric Winch
17	6509364	Trolley Base
18	3708456	Decal - Boom Capacity Symbol
19	K310101	5/16 Flat Washer
20	6509366	Spacer - Trolley Wheel

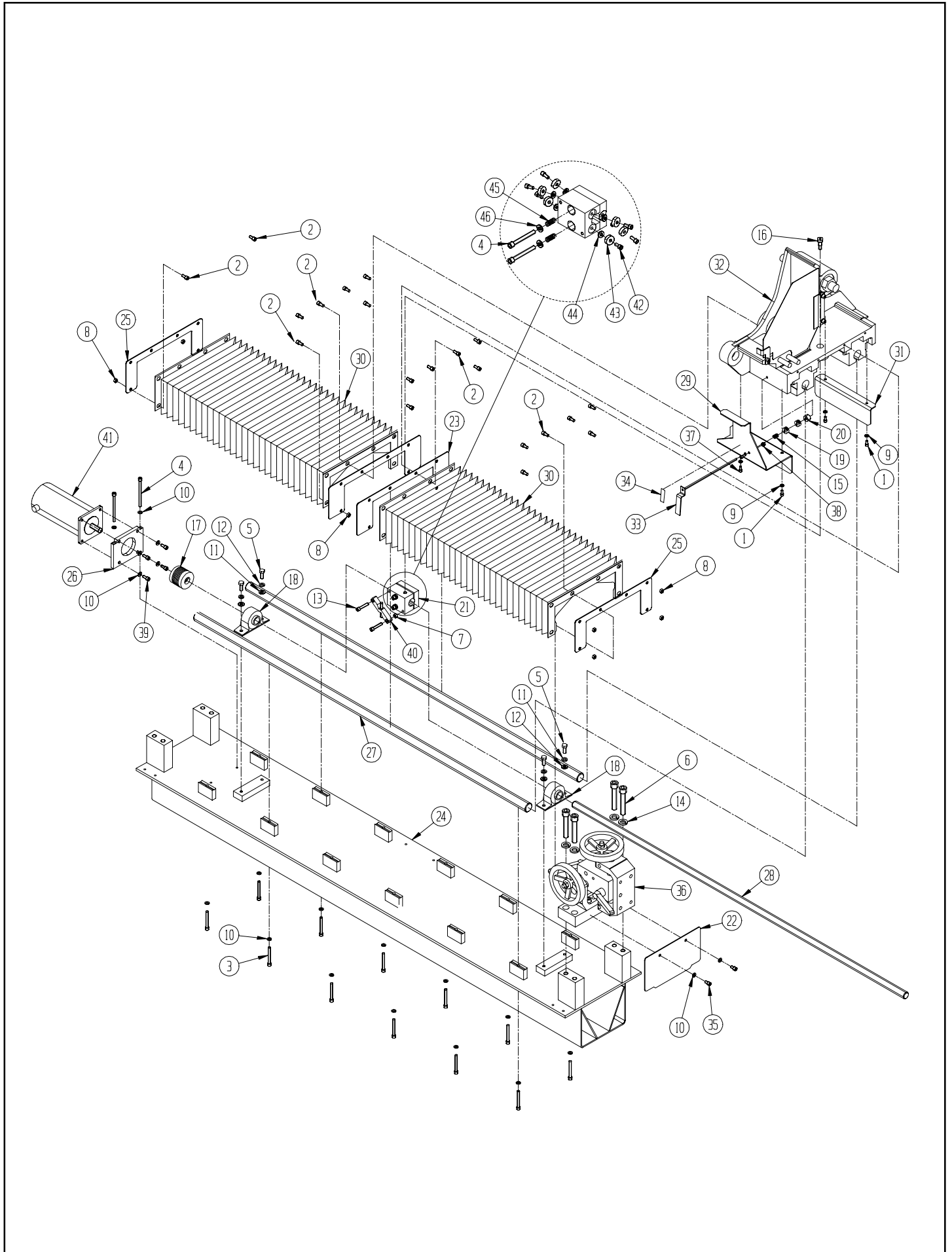

PARTS LIST (Bottom) 6309510 TRAVERSE AND CARRIAGE ASSEMBLY

<u>DIAGRAM NUMBER</u>	<u>PART NUMBER</u>	<u>DESCRIPTION</u>
1	B190611	Socket Head Cap Screw 10-24 x 3/8 Long
2	B250819	Button Head Socket Cap Screw 1/4-20 x 1/2 Long
3	B253211	Socket Head Cap Screw 1/4-20 x 2 Long
4	B255211	Socket Head Cap Screw 1/4-20 x 3.25 Long
5	B311201	Hex Head Cap Screw 5/16-18 x 3/4 Long
6	B503211	Socket Head Cap Screw 1/2-13 x 2 Long
7	J251000	1/4-20 Hexnut
8	J257100	1/4-20 Nylok Locknut
9	K191501	No. 10 Washer
10	K251501	1/4 Split Lockwasher
11	K310001	5/16 Flatwasher
12	K311501	5/16 Split Lockwasher
13	B252011	Socket Head Cap Screw 1/4-20 x 1 1/4 Long
14	K501501	1/2 Split Lockwasher
15	3619224	Compression Spring
16	3708147	Shoulder Bolt .375 Dia. x .625 Long
17	3709583	Flexible Coupling
18	3709635	Pillow Block Bearing
19	6009152	Shaft Collar
20	6009153	Rubber Washer
21	6509343	Actuator Assy.
22	6509020	Traverse Base Adjustable End Cap
23	6509021	Bellows Carriage Mounting Bracket
24	6509024	Machined Traverse Base
25	6509025	Bellows End Mounting Bracket
26	6509061	Motor Mount Bracket
27	6509063	Carriage Shaft
28	6509065	Carriage Drive Shaft
29	6509211	Carriage Proximity Flag Bracket
30	6509250	650 Way Cover Bellows
31	6509253	Carriage Dust Cover Bracket
32	6509566	Carriage Sub Assembly
33	6509585	Release Arm Weldment
34	3708454	Release Decal
35	B250616	Button Head Cap Screw 1/4-20 x 3/8
36	6509565	Cross Slide Sub Assembly
37	B190811	Socket Head Cap Screw 10-24 x 1/2 Long
38	J197000	10-24 Locknut - Jam
39	B251211	Socket Head Cap Screw 1/4-20 x 3/4 Long
40	6009548	Actuator Bar Assembly
41	6309085	Traverse Motor Assy
42	3709668	Socket Head Screw
43	3709597	Sealed Bearing
44	3709596	Spacer
45	3709469	Compression spring
46	K250001	1/4" Flat Washer

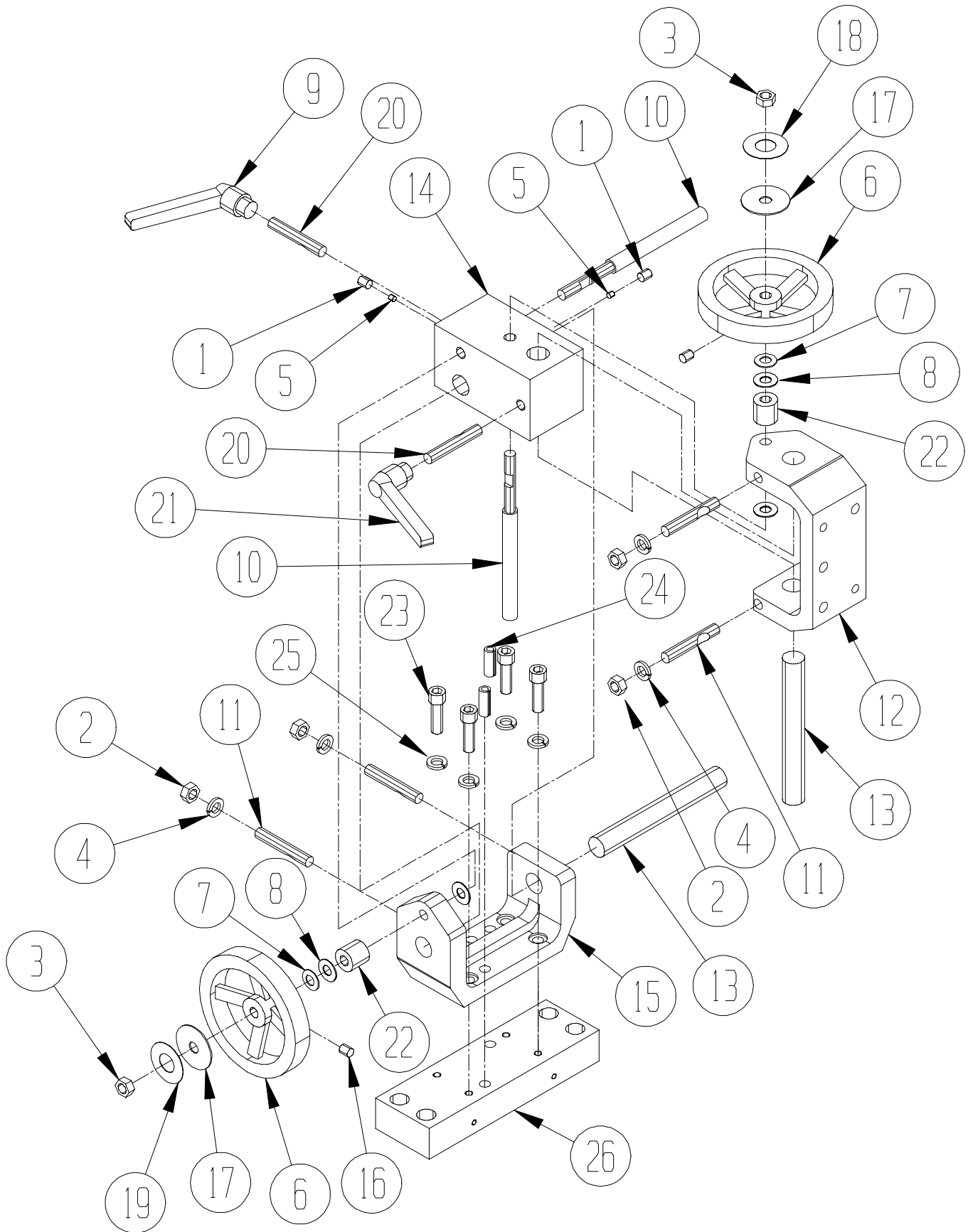

PARTS LIST (Continued)**6509565 CROSS SLIDE ASSEMBLY**

<u>DIAGRAM NUMBER</u>	<u>PART NUMBER</u>	<u>DESCRIPTION</u>
1	C311220	Socket Set Screw CPPT 5/16-18 x 3/4 Long
2	J371000	3/8-16 Hex Nut
3	J377000	3/8-16 Hex Jam Nylon Locknut
4	K371501	3/8 Split Lockwasher
5	3579109	3/16 Dia. Nylon Plug
6	3708148	Handwheel 4.5 Dia. .38 Bore
7	3709062	Bell V Washer .75 O. D. x .035 T
8	3709304	Thrust Washer
9	3708705	Adjustable Handle 5/16-18 Female - Orange
10	6509390	Adjusting ACME Shaft
11	6009035	Locking Stud Shaft
12	6009082	Cross Slide Support
13	6009095	Slide Shaft
14	6509011	Cross Slide
15	6509015	Cross Slide Horizontal support
16	C310820	Socket Set Screw 5/16-18 x 5/8 Long
17	3708665	Flat Washer
18	6309115	Grey Decal
19	6309114	Orange Decal
20	6309113	5/16-18 Locking Stud
21	3708706	Adjustable Handle 5/16-18 Female - Grey
22	3969065	Spacer .406 ID x .75 OD x 1.0 Long
23	B372011	Socket Head Cap Screw 3/8-16 x 1 1/4 Long
24	H371602	Rollpin 3/8 Dia. x 1 Long
25	K371501	3/8 Split Lockwasher
26	6509010	Traverse Base Adjuster Bracket

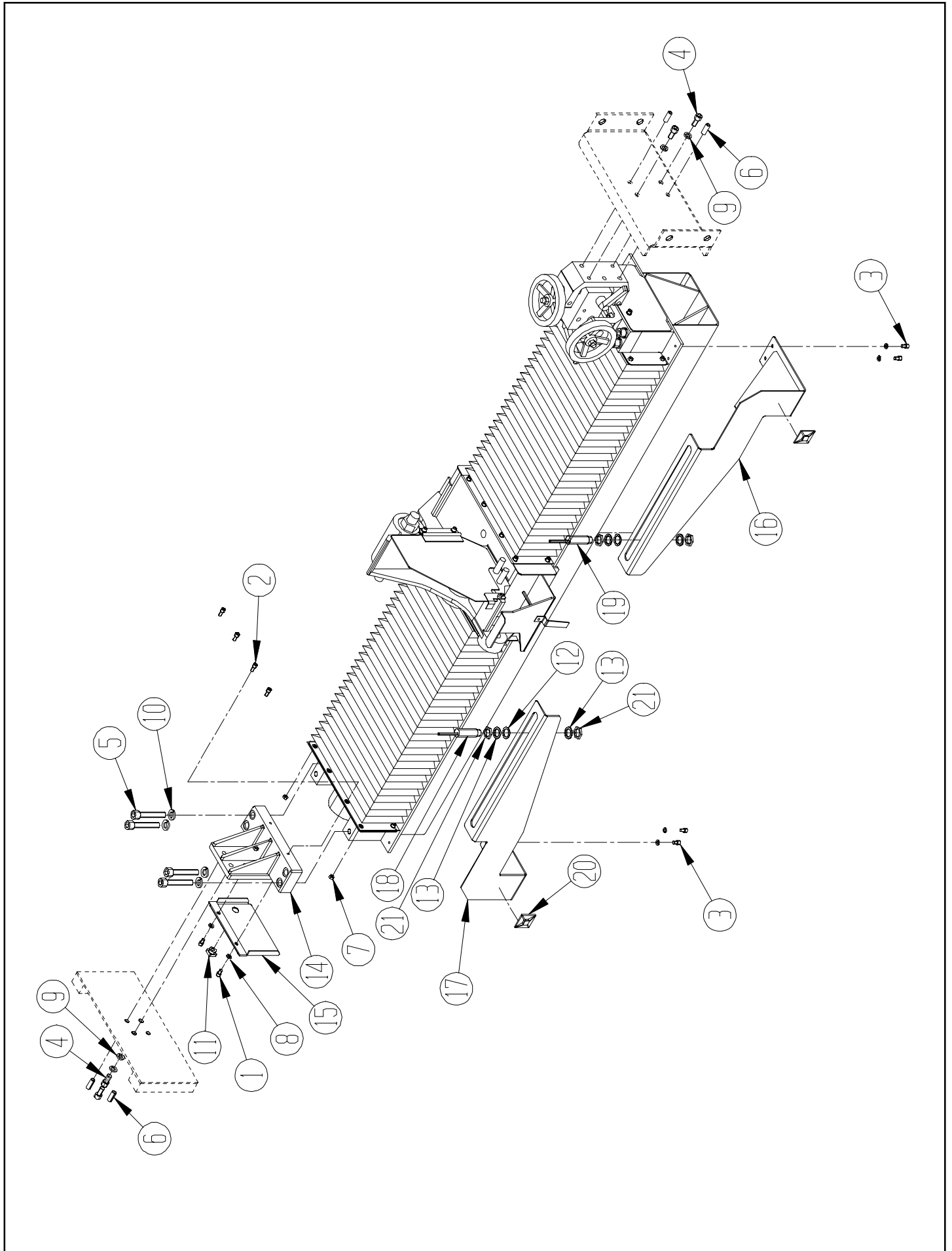

PARTS LIST (Continued)**6509530 TRAVERSE & CARRIAGE ASSEMBLY**

<u>DIAGRAM NUMBER</u>	<u>PART NUMBER</u>	<u>DESCRIPTION</u>
1	B250811	1/4-20 Socket Head Cap Screw x 1/2" Long
2	B250819	1/4" Truss Head Machine Screw x 1/2" Long
3	B251011	1/4-20 Socket Head Cap Screw x 5/8" Long
4	B371211	3/8-16 Socket Head Cap Screw x 3/4" Long
5	B503211	1/2-13 Socket Head Cap Screw x 2" Long
6	H371602	3/8" Dia. Roll Pin x 1" Long
7	J257100	1/4-20 Full Height Locknut
8	K251501	1/4 Lockwasher
9	K371501 3/8 Lockwasher
10	K501501	1/2 Lockwasher
11	3707279	Strain Relief
12	3708419	Wave Spring
13	3708421	Flat Washer - 3/4 ID x 1 OD x .075Thick
14	6509221	Fixed Traverse Base Bracket
15	6509553	Fixed End Cap Weldment
16	6509560	RH Proximity Switch Bracket Weldment
17	6509561	LH Proximity Switch Bracket Weldment
18	6509458	LH Traverse Proximity Switch
19	6509459	RH Traverse Proximity Switch
20	3707224	Cable Tie Mount (Used Throughout Machine)
21	3707459	Proximity Switch Nut

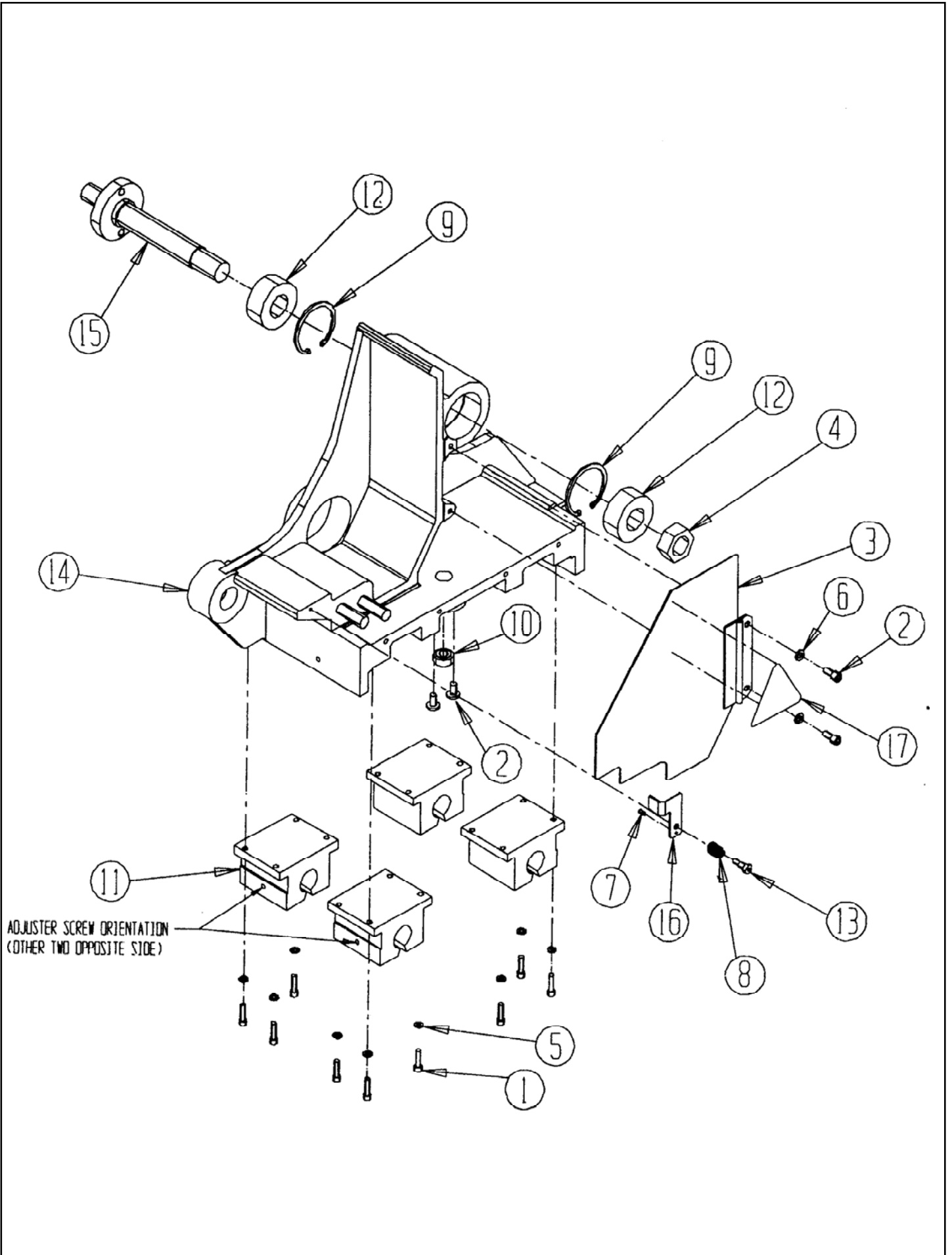

PARTS LIST (Continued)**6509566 CARRIAGE SUB ASSEMBLY**

DIAGRAM NO.	<u>PART NUMBER</u>	<u>DESCRIPTION</u>
1	B191211	Socket Head Cap Screw 10-24 x 3/4 Long
2	B250616	BS Head Cap Screw 1/4-20 x .38 Long
3	6509584	Swind Door Weldment
4	J887300	7/8-14 Nylok Jam Locknut
5	K191501	No. 10 Lockwasher
6	K251501	1/4 Split Lockwasher
7	R602031	#4 x .31 Drive Screw
8	3708105	Compression Spring
9	3708184	Retaining Ring
10	3709040	Spherical Bearing
11	3709044	Ball Bushing Bearing
12	3708186	Ball Bearing
13	3708208	Shoulder Bolt .250 Dia. x .387 Long
14	6509019	Carriage Base
15	6509023	Grinder Head Pivot Shaft
16	6509251	Swing Door Latch
17	3708462	Decal - RPM, Symbol

PARTS LIST

6309510 GRINDING HEAD ASSEMBLY (TOP)

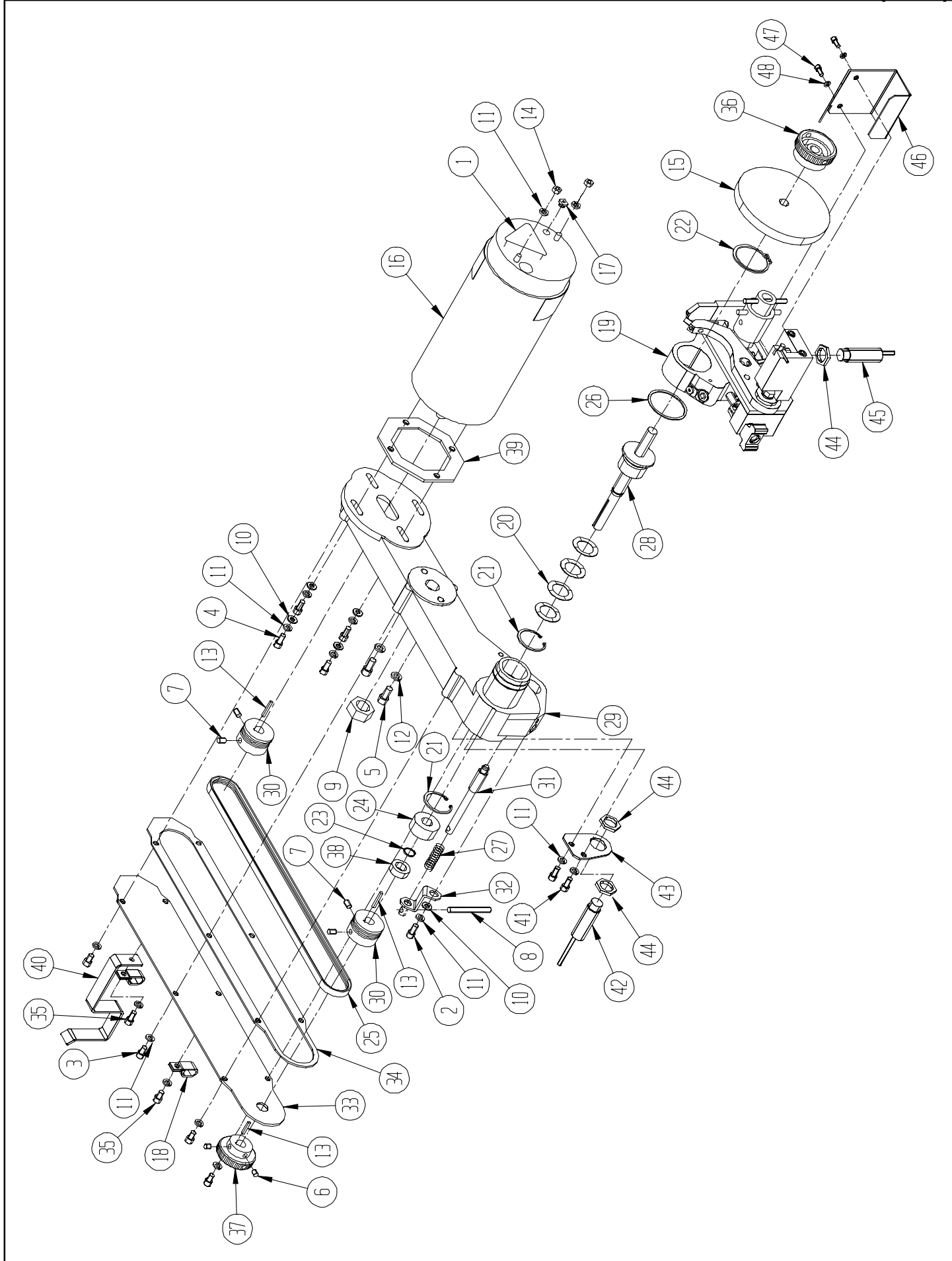

PARTS LIST (Continued)**6309510 GRINDING HEAD ASSEMBLY (TOP)**

<u>DIAGRAM NUMBER</u>	<u>PART NUMBER</u>	<u>DESCRIPTION</u>
1	3708448	Warning Electric Symbol
2	B250811	Socket Head Cap Screw 1/4-20 x 1/2 Long
3	B250818	Pan Head Machine Screw 1/4-20 x 1/2 Long
4	B251611	Socket Head Cap Screw 1/4-20 x 1 Long
5	B311611	Socket Head Cap Screw 5/16-18 x 1 Long
6	C250420	Socket Set Screw 1/4-20 x 1/4 Long
7	C250627	Socket Set Screw 1/4-20 x 3/8 Long Nylon Patch
8	H184002	Roll. Pin 3/16 x 2.5 Long
9	J757300	3/4-16 Full Nylok Locknut
10	K250001	1/4 Flat Washer
11	K251501	1/4 Split Lockwasher
12	K311501	5/16 Split Lockwasher
13	R000376	Square Key 1/8 x 3/4" Long
14	J257100	1/4-20 Locknut
15	3700089	Grinding Wheel 5" Dia. x 1" Wide
16	3707023	DC Motor 1 HP 90V
17	3707294	Strain Relief
18	3707935	Tube Clamp
19	6309573	Finger Sub Assembly
20	3708193	Conical Washer
21	3708194	Internal Retaining Ring 5000-137
22	3708195	External Retaining Ring 5100-187
23	3708196	Internal Retaining Ring 5100-59
24	3708204	Ball Bearing
25	3708202	Poly V Belt
26	3708436	Wave Spring
27	3709072	Compression Spring
28	6509578	Grinding Head Spindle Assembly
29	6509018	Grinding Head Housing
30	6509052	Poly V Pulley
31	6509484	Plunger Pin
32	6509054	Plunger Pin Retainer
33	6509055	Belt Cover
34	6509210	Belt Cover Gasket
35	B251016	Button Head Socket Cap Screw 1/4-20 x 5/16 Long
36	6509237	Grinding Wheel Knob
37	6509238	Grip Grinding Wheel Knob
38	6509247	Pulley Spacer
39	6509256	Motor Spacer
40	6509269	Vac Hose Bracket
41	B250618	1/4-20 Pan Head Machine Screw x 3/8 Long
42	6509460	Proximity Switch - Head Position
43	6509216	Proximity Switch Bracket
44	3707459	Proximity Switch Nut
45	6509461	Proximity Switch - Finger Position
46	6509230	Proximity Switch Guard
47	B190634	#10-32 Button Head Socket Cap Screw x 3/8 Long
48	K191501	#10 Lockwasher

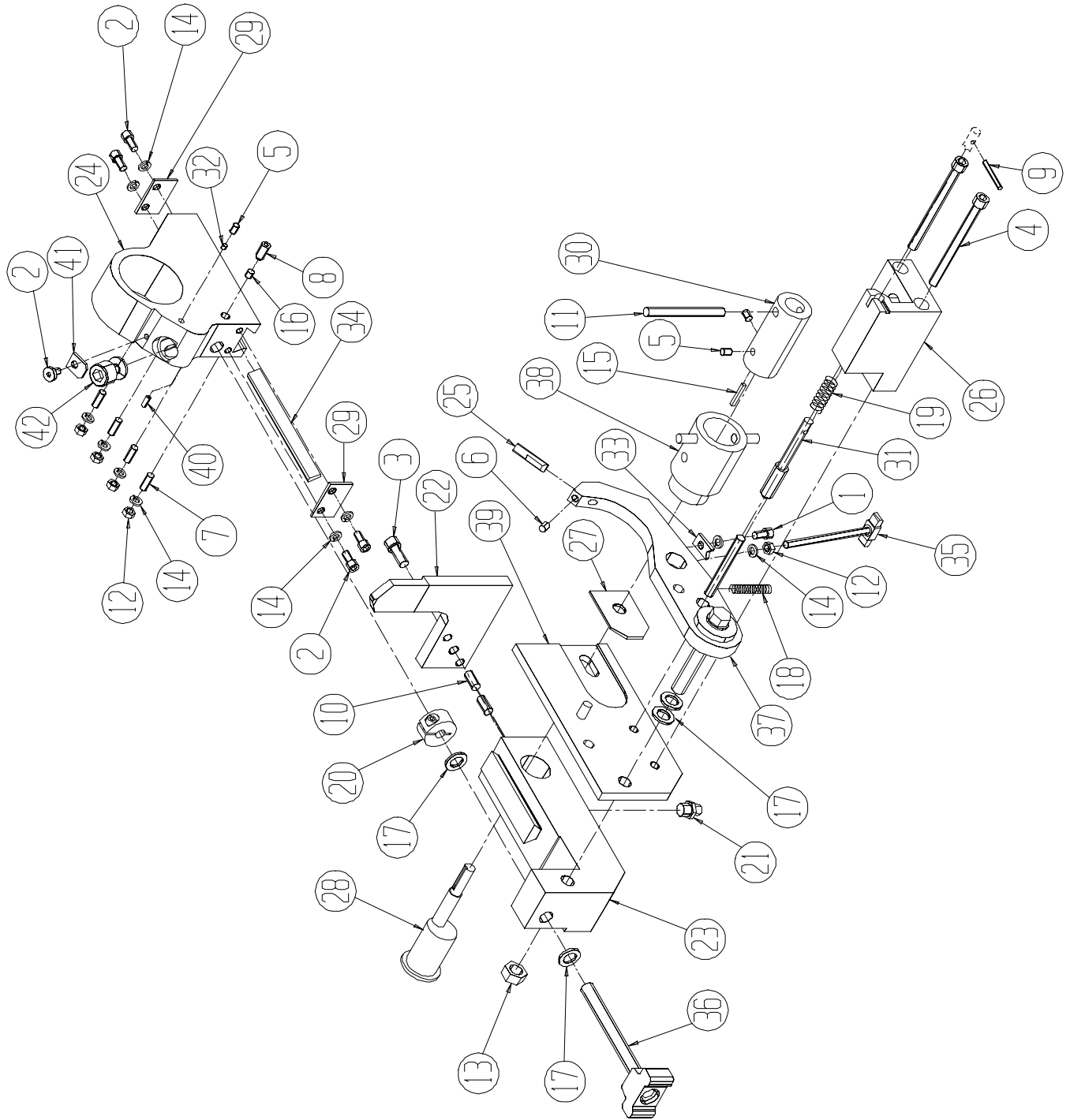

PARTS LIST (Continued)**6309573 FINGER AND BODY ASSEMBLY**

<u>DIAGRAM NUMBER</u>	<u>PART NUMBER</u>	<u>DESCRIPTION</u>
1	B190631	Socket Head Cap Screw 10-32 x 3/8 Long
2	B190634	Button Head Socket Cap Screw 10-32 x 3/8 Long
3	B251011	Socket Head Cap Screw 1/4-20 x 5/8 Long
4	B254811	Socket Head Cap Screw 1/4-20 x3 Long
5	C190460	Socket Set Screw 10-24 x 1/4
6	C190467	Socket Set Screw - Nylok Cup 10-32 x .25 Long
7	C190860	Socket Set Screw - CP-PT 10-32 x 1/2 Long
8	C190860	Socket Set Screw - 10-32 x 1/2 Long
9	H122002	Roll Pin 1/8 Dia. x 1 1/4 Long
10	H250813	Dowel Pin 1/4 Dia. x .5 Long
11	H254009	Drive Lock Pin 1/4 x 2.5 Long
12	J191100	10/32 Hex Nut
13	J377200	3/8-24 Jam Nylok Locknut
14	K191501	No. 10 Lock Washer
15	R000351	Square Key .093 x .75 Long
16	3579284	1/8 Dia. Nylon Plug
17	3709304	Thrust Washer
18	3708107	Compression Spring
19	3708175	Compression Spring
20	3708199	3/8-16 Dia. Split Shaft Collar
21	3709472	Straight Grease Fitting
22	6509432	Relief Finger
23	6509004	Reel Finger Slide
24	6509357	Reel Finger Positioner
25	6509007	Index Stop Pin
26	6509008	Index Sensor Block
27	6509009	Slide Washer
28	6509058	Eccentric Index Pin
29	6509060	Gib Stop Plate
30	6509215	Adjustable Index Lever
31	6509229	Locking Index Finger Pin
32	3579284	1/8" Diameter Nylon Plug
33	6509239	Anti Rotation Plate
34	6509258	Dovetail Gib
35	6509501	Tee Knob Assembly
36	6509547	Knob Assembly
37	6509572	Index Finger Assembly
38	6509591	Index Lock Handle Weldment
39	6509592	Index Finger Positioner Weldment
40	H120402	1/8" Diameter x 1/4" Long Pin Roll
41	6509358	Stop Plate
42	6509356	Reel Positioner Adjuster

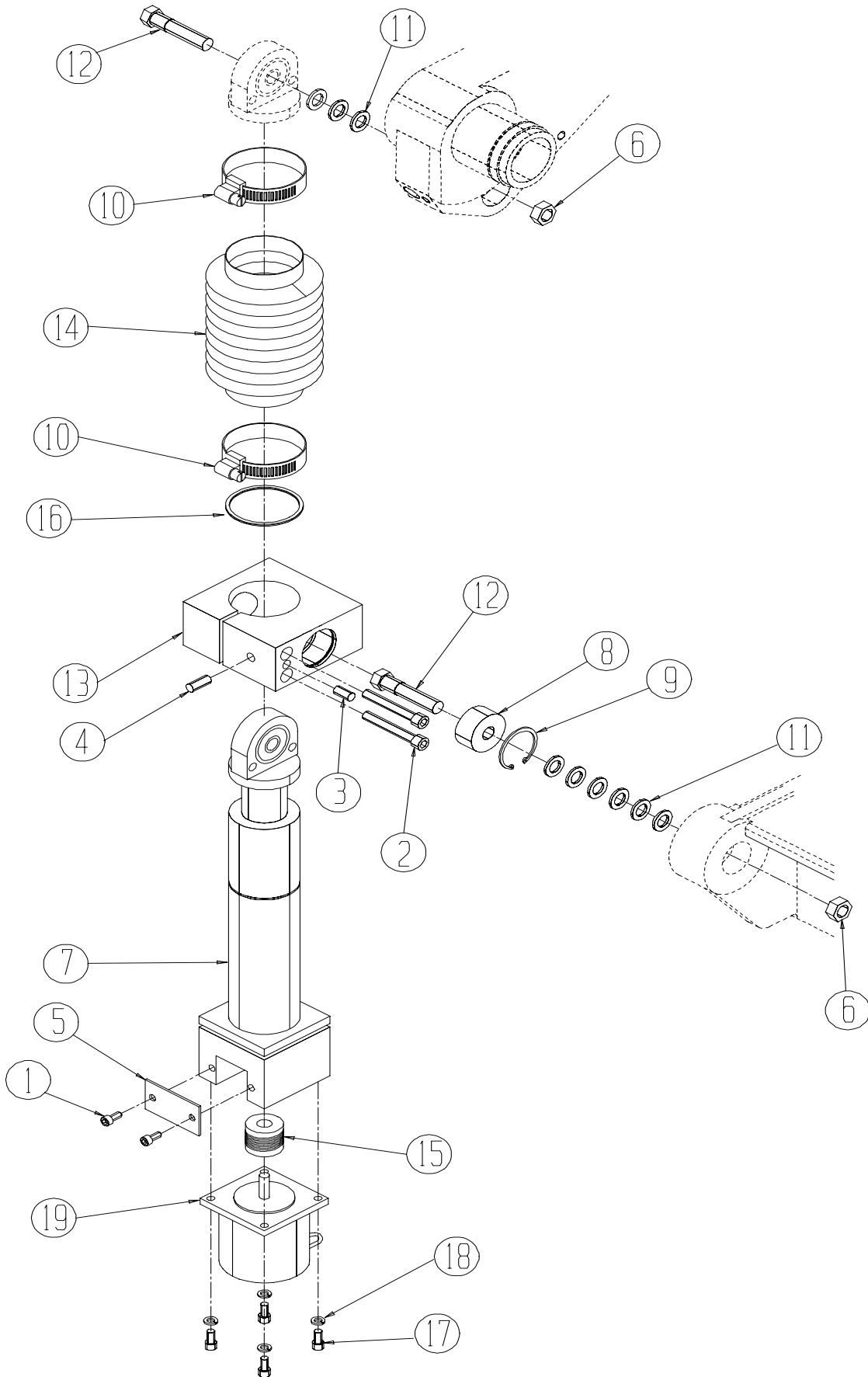

PARTS LIST (Continued) 6509574 STEPPER & MOUNTING ASSEMBLY

DIAGRAM NO.	PART NUMBER	DESCRIPTION
1	B190613	Button Head Cap Screw #10-24 x 3/8 Long
2	B252811	Socket Head Cap Screw 1/4-20 x 1 3/4 Long
3	C250825	Socket Set Screw 1/4-20 x 1/2
4	C251020	1/4-20 x 5/8" Set Screw
5	6509381	Base Cover Plate
6	J377200	3/8-24 Nylok Jam Locknut
7	6509384	Infeed Stepper Assy.
8	3708187	Ball Bearing
9	3708189	Retaining Ring
10	3708192	Hose Clamp 2.25 Dia.
11	3709304	Thrust Washer
12	6509048	Hex Pivot Pin
13	6509051	Trunion Block
14	6509056	Bellows, 1.88 I. D.
15	3708629	Flex Coupling
16	3708424	Spiral Retaining Ring
17	B190811	Socket Head Cap Screw 10-24 x 1/2 Long
18	K191501	No. 10 Lock Washer
19	6509470	Stepper Infeed Motor

PARTS LIST

6509434 CONTROL PANEL ASSEMBLY

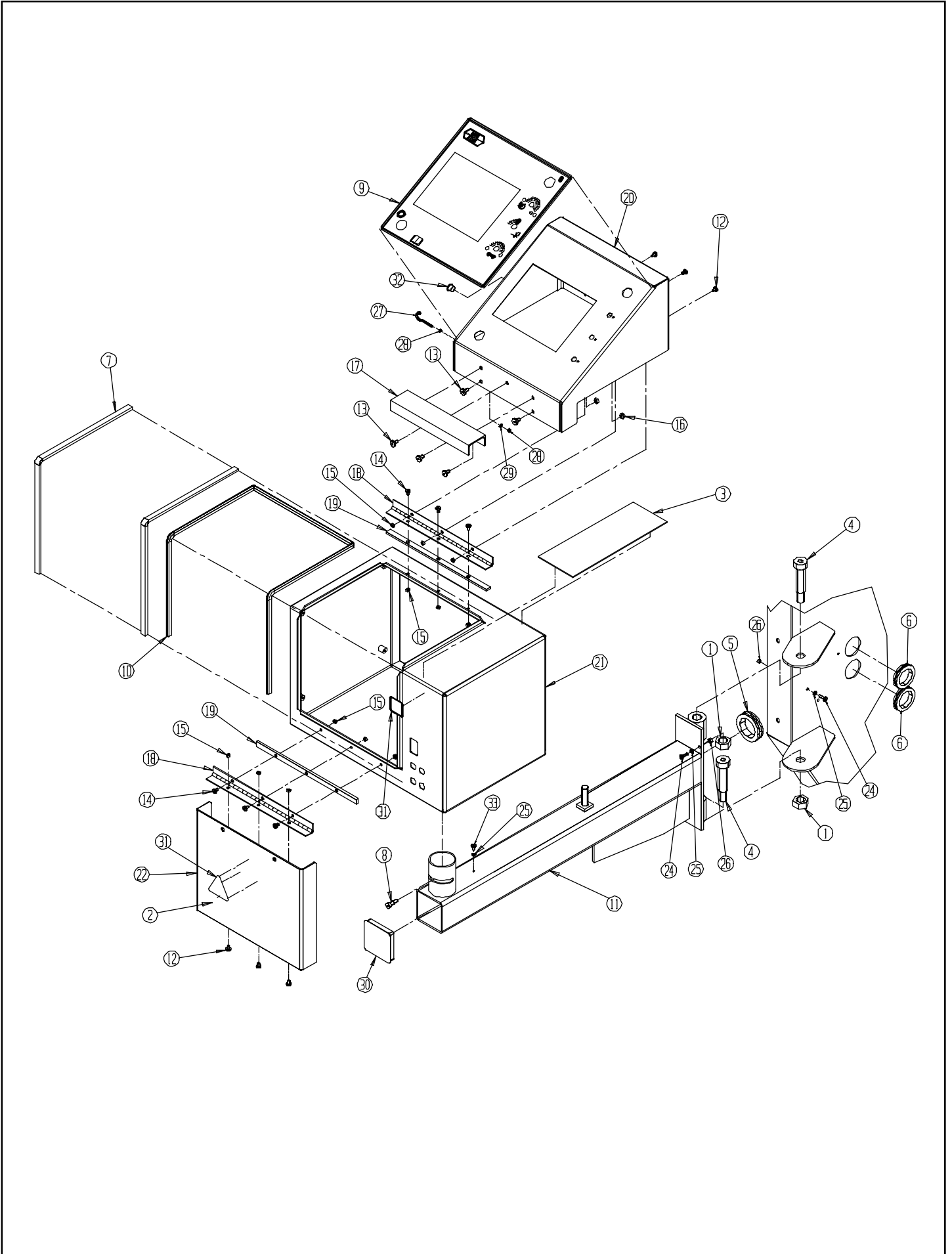

PARTS LIST (Continued)**6509434 CONTROL PANEL ASSEMBLY**

DIAGRAM NO.	<u>PART NUMBER</u>	<u>DESCRIPTION</u>
1	J627100	Full Nylok Locknut 5/8-11 Long
2	3708448	Warning Decal
3	3708203	Rubber Pad
4	3708371	Shoulder Bolt .75 Dia. x 2.25 Long
5	3708375	Grommet 1.75 I.D. .25 Groove
6	3708376	Grommet 1.50 I.D. .125 Groove
7	3708378	Foam Strip
8	3708425	Shoulder Bolt .312 Dia. x .375 Long
9	6509433	Control Panel Decal
10	6509096	Rubber Trim
11	6509558	Control Arm Weldment
12	B190834	Button Head Cap Screw 10-32 x 1/2 Long
13	B250816	Button Head Socket Cap Screw 1/4-20 x 1/2 Long
14	B191034	Button Head Cap Screw 10-32 x 5/8 Long
15	J197300	10-32 Locknut
16	J257000	1/4-20 Nylok Inst. Locknut
17	6509112	Handle
18	6509212	Control Panel Hinge
19	6509213	Control Panel Hinge Spacer
20	6509423	Top Swing Panel Weldment
21	6509428	Control Box Weldment
22	6509575	Front Swing Panel Weldment
23	B250816	Button Head Socket Cap Screw 1/4-20 x 1/2 Long
24	B190809	Phillip Head Cap Screw 10-24 x 1/2
25	R000483	#10 Toothed Lock Washer
26	R000553	10-24 Lock Nut
27	3708426	Chart Holder Hook
28	J161000	8-32 Nut
29	K161501	#8 Lockwasher
30	3708427	3" Square Plug
31	3708696	650 Patent Decal
32	3709372	1/2" Hole Plug
33	B190611	#10-32 Socket Head Cap Screw x 3/8 Long

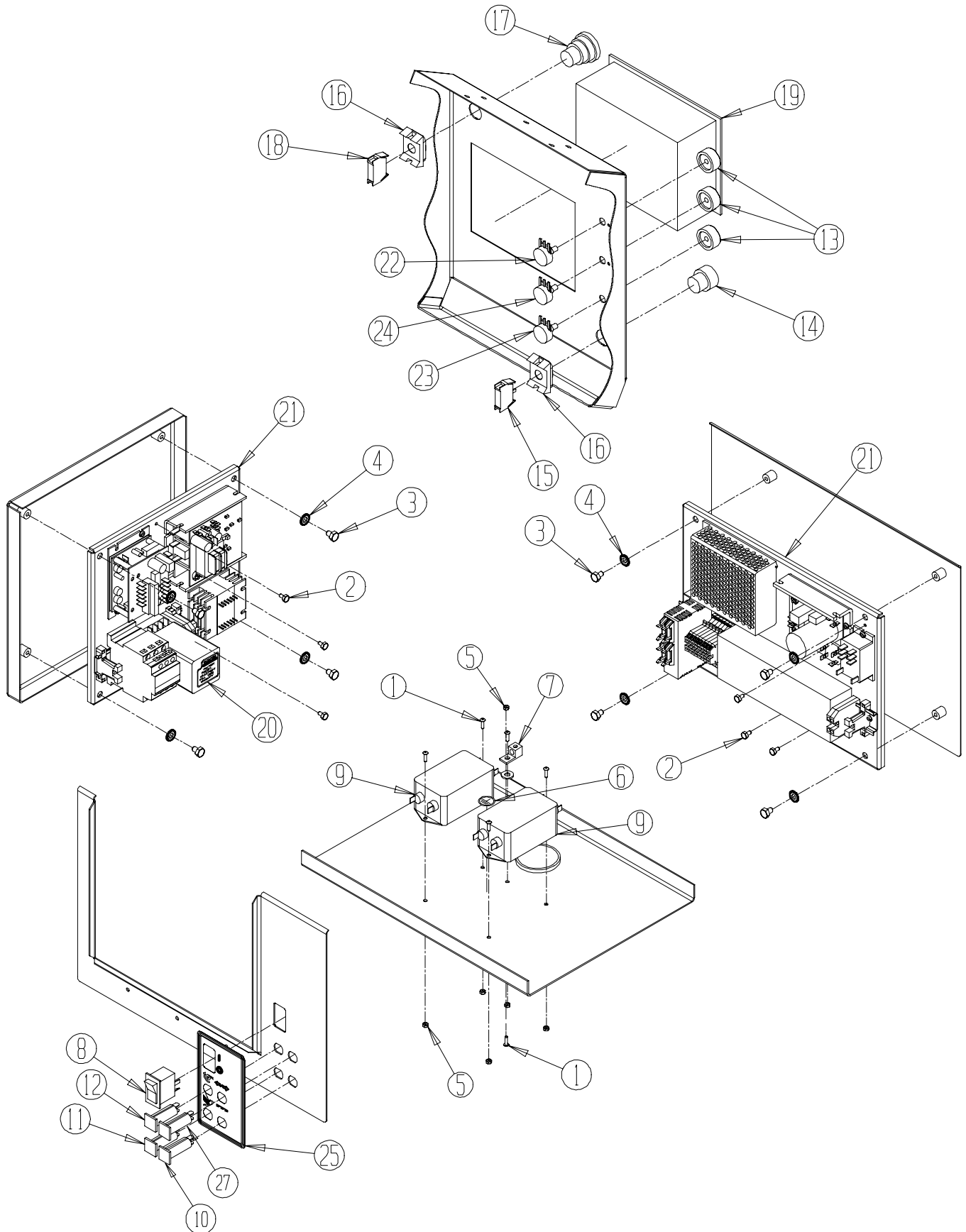

PARTS LIST (Continued)**6509434 CONTROL PANEL ASSEMBLY**

<u>DIAGRAM NO.</u>	<u>PART NUMBER</u>	<u>DESCRIPTION</u>
1	B160607	#8-32 Button Head Cap Screw x 3/8" Long
2	D160600	#8 Pan Head Self-Tapping Machine Screw
3	D250800	1/4 Self Tapping Machine Screw
4	R000536	1/4 Lock Washer With Teeth
5	R000558	#8-32 Kep Nut
6	3707163	Primary Ground Decal
7	3707164	Primary Ground Lug
8	3707367	On/Off Rocker Switch
9	3707403	Power Line Filter
10	3707442	2 - Amp Circuit Breaker
11	3707443	4 - Amp Circuit Breaker
12	3707444	10 - Amp Circuit Breaker
13	3707446	Potentiometer Knob With Pointer
14	3707564	Green Pushbutton - Start
15	3707565	Normaly Open Contact Block
16	3707566	Mounting Switch for Pushbutton
17	3707567	Red Push/Pull Button - Stop
18	3707568	Normaly Closed Contact Block
19	3707572	5.7" Color Touch Screen
20	3708683	Low Voltage Warning Decal
21	6509444	Electrical Panel Sub-Assembly
22	6509445	Traverse Potentiometer
23	6509446	Spin Speed Potentiometer
24	6509447	Relief Torque Potentiometer
25	6509468	Power Switch Decal
26	6509472	Decal-Mirror
27	3707399	3 - Amp Circuit Breaker

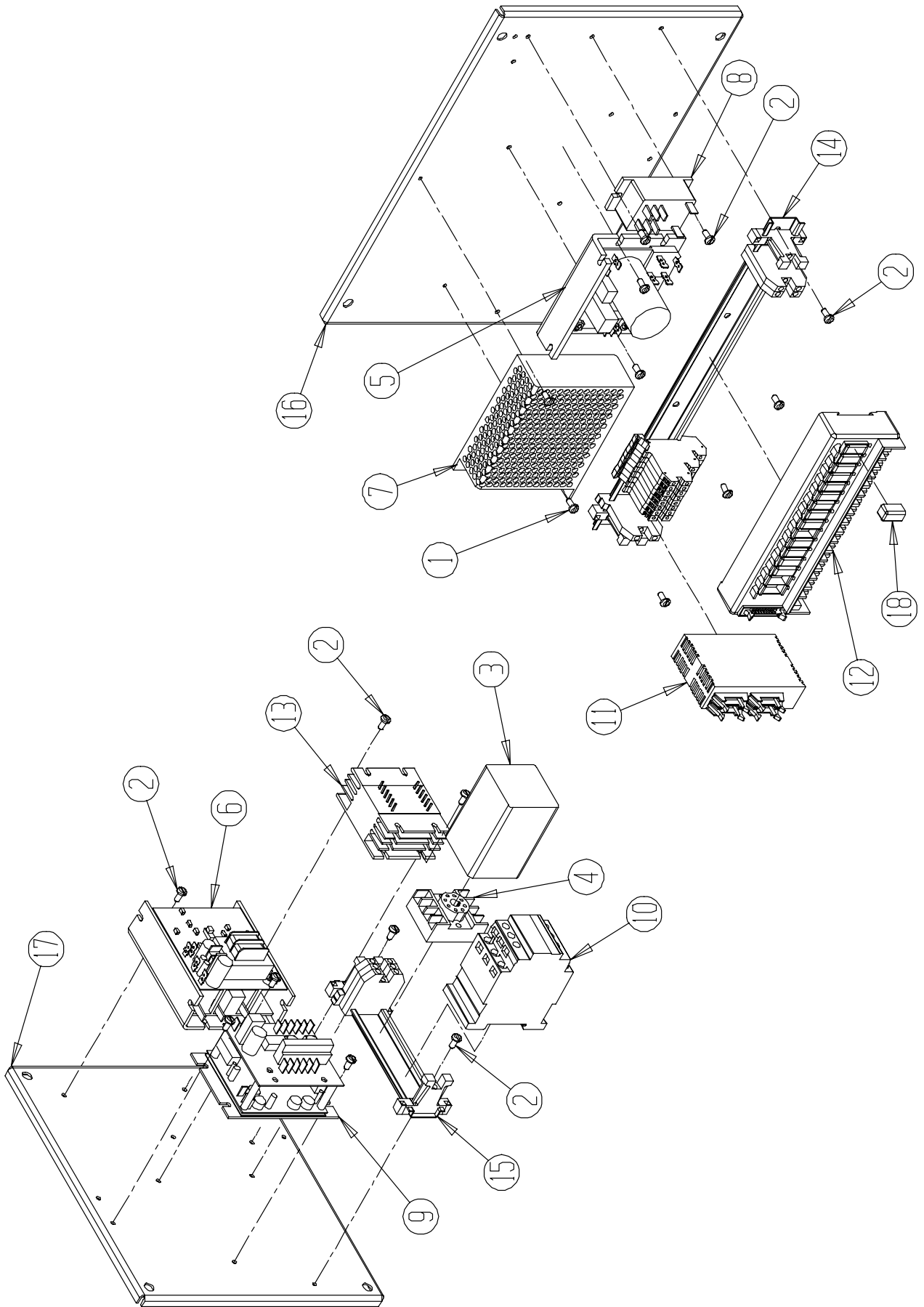

PARTS LIST (Continued)**6509444 CONTROL PANEL SUB-ASSEMBLY****DIAGRAM****NO.****PART NUMBER****DESCRIPTION**

1	D130608	#6 Pan Head Thread Cutting Machine Screw
2	D160666	#8 Pan Head Thread Cutting Machine Screw
3	3707558	Low Voltage Sensor
4	3707073	8-Pin Socket
5	3707317	Grind Motor Board
6	3707321	Traverse Control Board
7	3707322	DC Power Supply
8	3707431	24V DC Relay
9	3707524	Spin/Relief Control Board
10	3707556	Magnetic Starter
11	3707569	PLC
12	3707571	PLC Output Block w/Relays
13	3707577	Stepper Motor Drive
14	3707581	Terminal Block Assembly - Rear
15	3707582	Terminal Block Assembly - Side
16	6509424	Rear Electrical Panel
17	6509425	Side Electrical Panel
18	3707574	5-Amp Relay for PLC Output Block

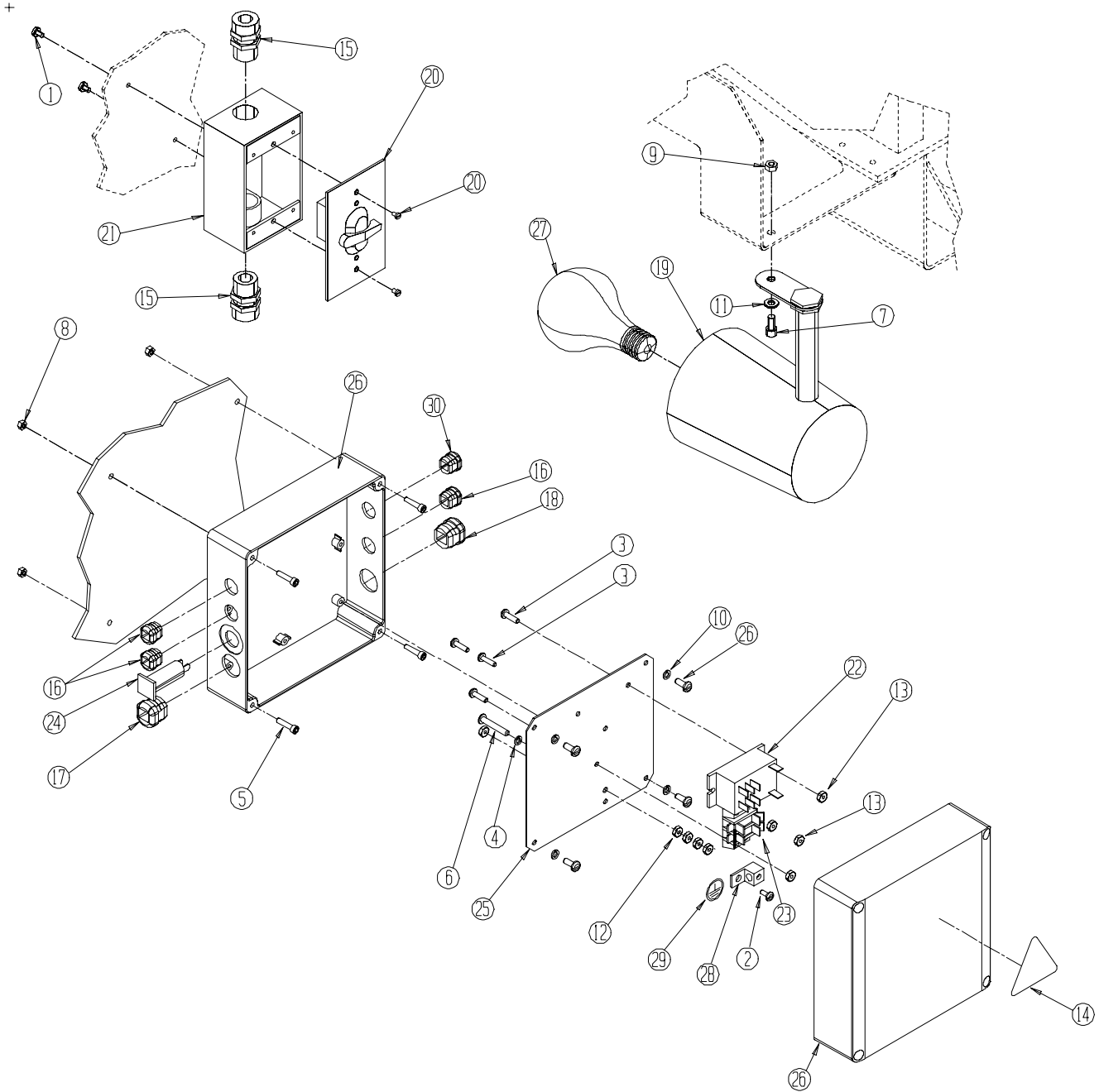

PARTS LIST (Continued) 6509598 JUNCTION BOX AND LIGHT ASSEMBLY

<u>DIAGRAM NO.</u>	<u>PART NUMBER</u>	<u>DESCRIPTION</u>
1	B160607	Button Head Socket Cap Screw 8-32 x 1/4
2	B160613	Phillip Head Mach. Screw 8-32x3/8
3	B161014	Phillip Head Mach. Screw 8-32 x 5/8
4	R000483	#10 Lock Washer
5	B161211	Socket Head Cap Screw 8-32 x 3/4
6	B192013	Button Head Socket Cap-Full Thread 10-24 x 1.25
7	B251201	Hex Head Cap Screw 1/4-20 x 3/4
8	J167000	8-32 Lock Nut
9	J257100	1/4-20 Nylok Lock Nut
10	K161501	No. 8 Lock Washer
11	K250101	Flat Washer
12	R000553	10-24 Kep Nut
13	R000558	8-32 Kep Nut
14	3708448	Warning Decal
15	3707180	Liquid Tight Connector
16	3707273	Strain Relief Wire .33/.36
17	3707275	Strain Relief Wire .37/.43
18	3707294	Strain Relief Wire .43/.47
19	6509340	4" Stem Machine Light
20	3707412	Electrical Box Cover with Switch
21	3707413	Aluminum Electrical Box
22	3707447	DPDT 120VDC Coil Relay
23	3707439	.25 Spade Terminal Block
24	3707444	10 AMP Circuit Breaker
25	6509480	Electric Junction Panel
26	6509481	Junction Box
27	3707046	Rough Service 100 Watt
28	3707164	Primary Ground Lug
29	3707163	Primary Ground Decal
30	3707279	Strain Relief .30

PARTS LIST

6309538 MOWER SUPPORT ASSEMBLY

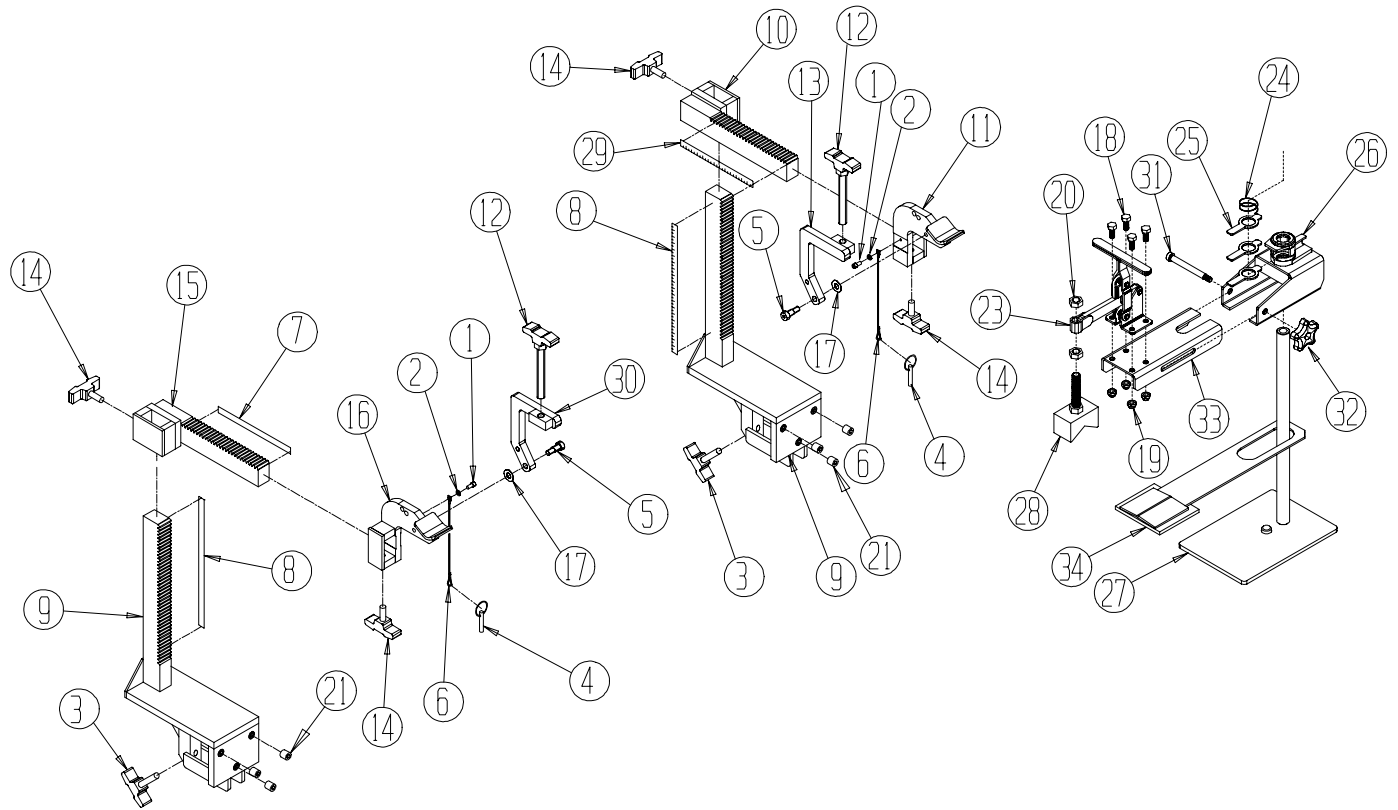

PARTS LIST (Continued)**6309538 MOWER SUPPORT ASSEMBLY**

<u>DIAGRAM NUMBER</u>	<u>PART NUMBER</u>	<u>DESCRIPTION</u>
1	B190614	Pan Head Machine Screw 10-24 x 3/8 Long
2	K191501	No.10 Lockwasher
3	6009577	Knob Assembly
4	3708364	Quick Release Pin .31 Dia.
5	3708158	Shoulder Bolt .375 Dia. x .50 Long
6	3708366	6" type B Lanyard
7	6509128	Horizontal Scale Decal RH
8	6509129	Vertical Scale Decal
9	6509507	Bar Mounting Weldment Bracket
10	6509517	L.H. Front Roller Horiz. Weldment Bracket
11	6509422	L. H. Roller Clamp Weldment Bracket
12	6509559	Knob Assembly
13	6509564	L.H. Front Roller Clamp Weldment
14	6509588	Knob Assembly
15	6509515	R.H. Front Roller Horiz. Weldment Bracket
16	6509421	R.H. Roller Clamp Weldment Bracket
17	3709304	Thrust Washer
18	B311201	Hex Head Cap Screw 5/16-18 x 3/4 Long
19	J317100	5/16-18 Nylok Locknut
20	J507000	1/2-13 Hex Jam Nut
21	C500861	1/2-20 x 1/2 Flat Pt Socket Head Set Screw
23	6309534	Toggle Clamp
24	3709849	Pony Clamp Spring
25	3709858	Pony Leaf
26	6309532	R.R. Clamp Arm Weldment
27	6309536	R.R. Clamp Base Weldment
28	6509545	R.R. Clamp Block Weldment
29	6509304	Horizontal Scale Decal LH
30	6509576	R.H. Front Roller Clamp Weldment
31	3708579	Shoulder Bolt .375 x 3.25 Long
32	3709613	Star Knob
33	6309022	Slide
34	6309544	Rear Roller Bracket Weldment

PARTS LIST

6509465 SPIN DRIVE ASSEMBLY

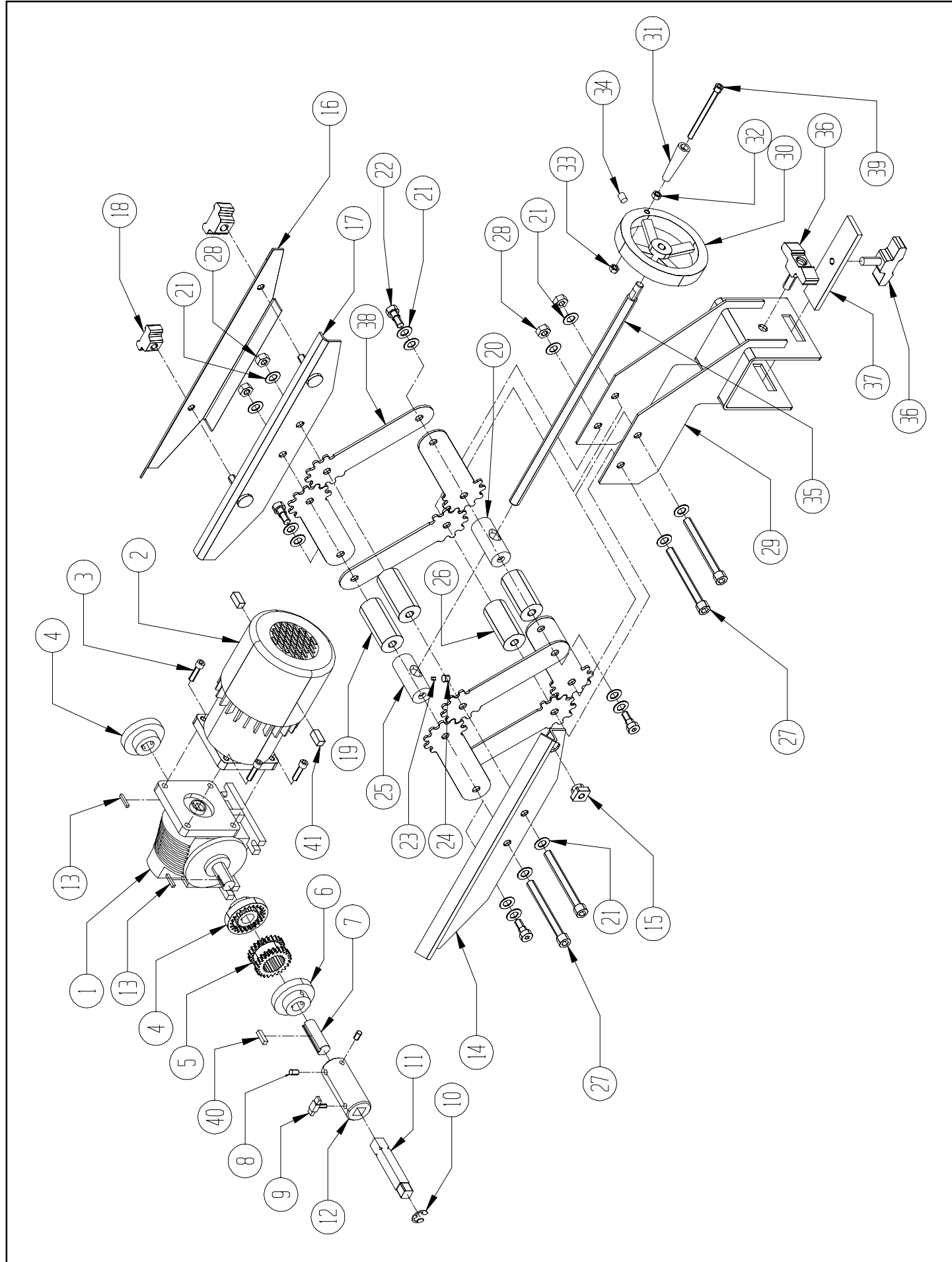

PARTS LIST (Continued)**6509465 SPIN DRIVE ASSEMBLY**

DIAGRAM NO.	PART NUMBER	DESCRIPTION
1	3708391	Reducer: 10:1 Ratio
2	6509457	Motor, DC .20 HP TEFC
3	B251411	Self Tapping Screw 1/4-20 x 1 Long
4	3709586	Flange Coupler .50
5	3709585	Sleeve Coupler
6	3709584	Flange Coupler 5/8
7	6009217	Drive Coupling Adapter
8	C250620	Socket Set Screw 1/4-20 x 3/8
9	6009598	Tee Knob Assembly .50 Long
10	3709073	Retaining Ring
11	6009051	Drive Adapter 1/2 Square
12	6009052	Adapter
13	R000376	Square Key 1/8 x .75 Long
14	6009078	Gearbox Slide Bracket
15	3707279	Strain Relief Wire
16	6009079	Gearbox Clamp Bracket
17	6009580	Gear Box Slide Weldment Bracket
18	3708262	T-Knob 5/16-18
19	6009048	Linkage Spacer 2.29 Long
20	6009046	Linkage Spacer R.H. Thread
21	3709062	Belleville Washer .75 Dia. x .035 T
22	3709809	Shoulder Bolt .375 Dia. x .375 Long
23	3709705	Nylon Ball 5/32 Dia.
24	C310420	Socket Set Screw 5/16-18 x 1/4
25	6009047	Linkage Spacer L.H. Thread
26	6009045	Linkage Spacer 2.5 Long
27	B375611	Socket Head Cap Screw
28	J377100	Nylock Hex Locknut 3/8-16
29	6509519	Support Bracket Weldment
30	3708148	Handwheel 4.5 Dia.
31	3709370	Handle
32	J252000	Hex Jam Nut 1/4-20
33	J257000	1/4-20 Nylok Locknut
34	C310620	Socket Set Screw 5/16-18 x 3/8 Long
35	6009076	Double Thread Rod
36	6009555	Knob Assembly
37	6509114	Spin Drive Plate Lock
38	6009067	Geared Linkage
39	B255011	Socket Head Cap Screw 1/4-20 x 3 1/8 Long
40	R000377	Square Key 3/16 x .75 Long
41	3707254	DC Motor Brush

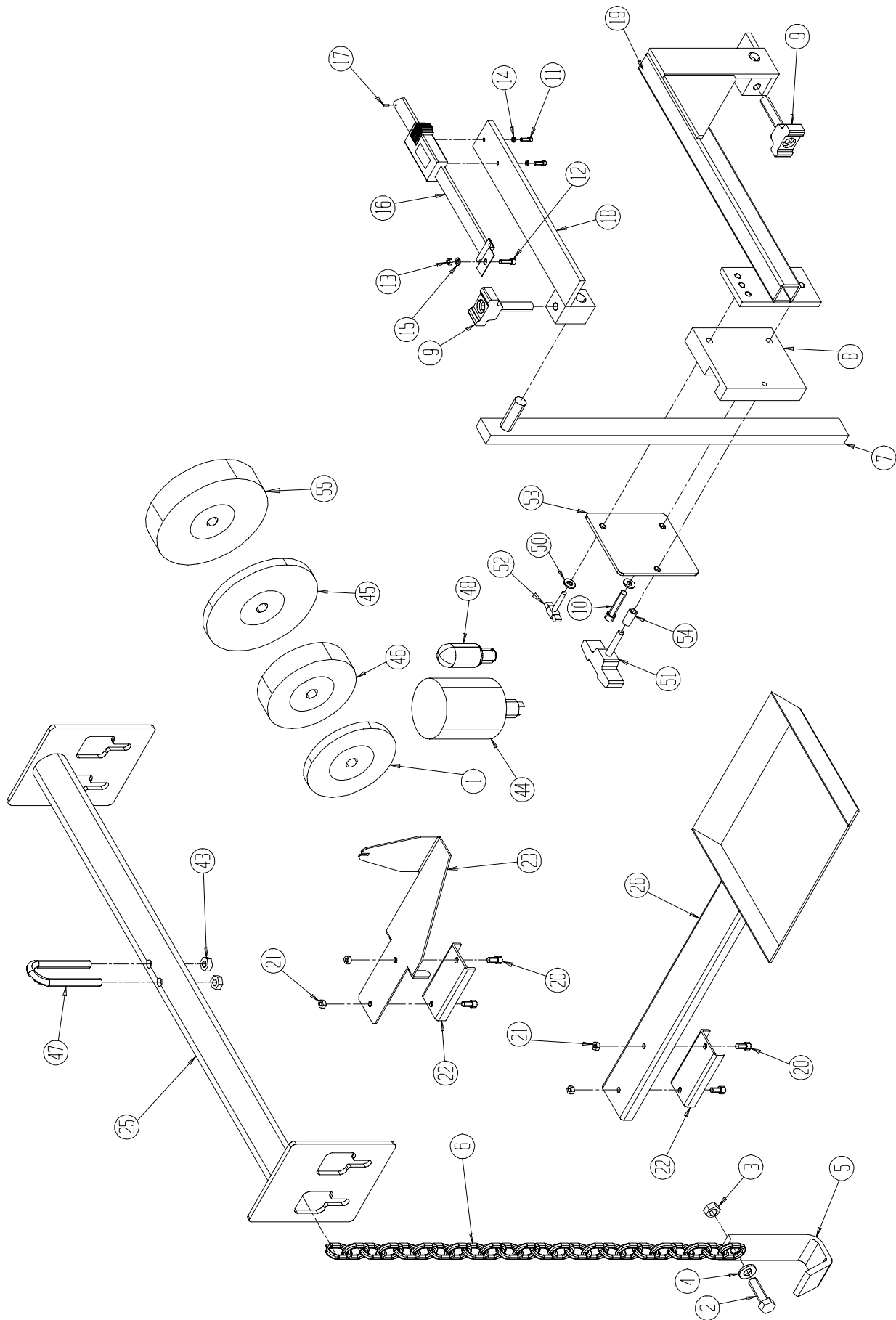

PARTS LIST (Continued)**6509549 MISCELLANEOUS PARTS**

DIAGRAM NO.	PART NO.	DESCRIPTION
1	3700088	Grinding Wheel 3.5" Dia. x .38 W
2	B371601	Hex Head Cap Screw 3/8-16 x 1 Long
3	J377100	Nylok Locknut
4	K370001	3/8 Flat Washer
5	6009102	Grab Hook
6	6509113	Chain
7	6509569	Gage Bar Assembly-Vertical
8	6509418	Pivot Plate
9	6509567	Knob Assembly
10	B252011	1/4-20 x 1.25 Socket Head Cap Screw
11	B120611	Socket Head Cap Screw 5-40 x .38 Long
12	B161011	Socket Head Cap Screw 8-32 x 5/8 Long
13	J161000	8-32 Hex Nut
14	K121501	No. 5 split Lockwasher
15	K161501	No. 8 Lockwasher
16	6509359	Digital Gage
17	H060302	1/16" x 3/16" Roll Pin
18	6509412	Base Weldment Indicator
19	6509568	Alignment Extension Weldment
20	B190811	Socket Head Cap Screw 10-24 x 1/2
21	J197100	10-24 Nylok Locknut
22	3708384	Magnet
23	6509143	Reel Positioner Gage
25	6509590	Spreader Bar Weldment
26	6509557	Drip Pan Weldment
43	J317100	5/16-18 Lock Nut
44	6509411	Amber Light Assembly (Lense, Socket, Flasher & Bulb)
45	3700087	Grinding Wheel 5" Dia. x .38" Wide
46	3700086	Grinding Wheel 3.5" Dia. x 1" Wide
47	3709316	5/16-18 x 3" U-Bolt 1 1/2"
48	3707465	25W Light Bulb
50	K251501	1/4 Lock Washer
51	6609501	T-Knob Assembly
52	3708813	T-Knob Assembly
53	6509349	Retainer Plate
54	3529069	Spacer
55	3700089*	Grinding Wheel 5" Dia.x 1" Wide

* 3700089- Grinding wheel is installed on grinding head when shipped. The other wheels are located in the carton assembly.

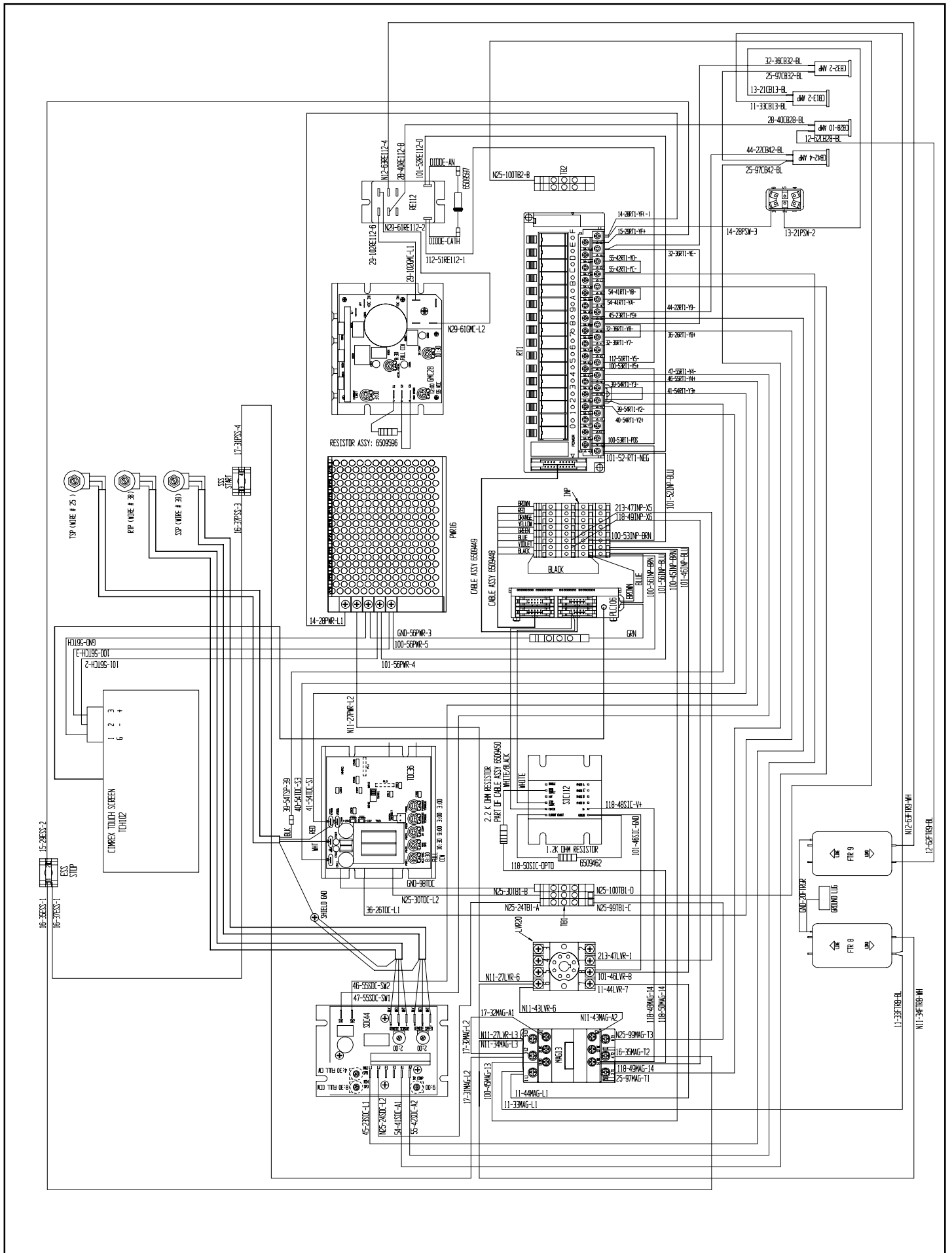

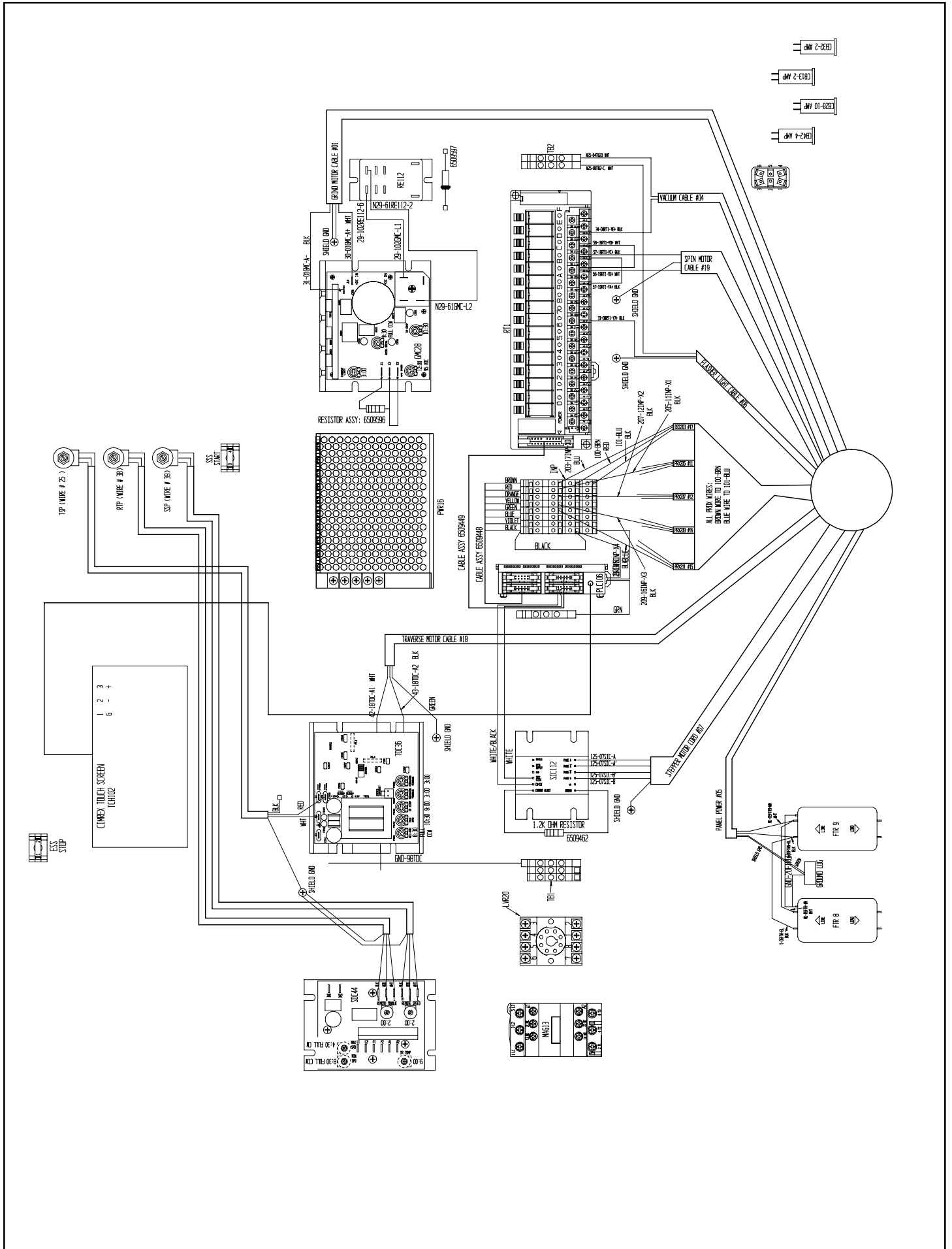

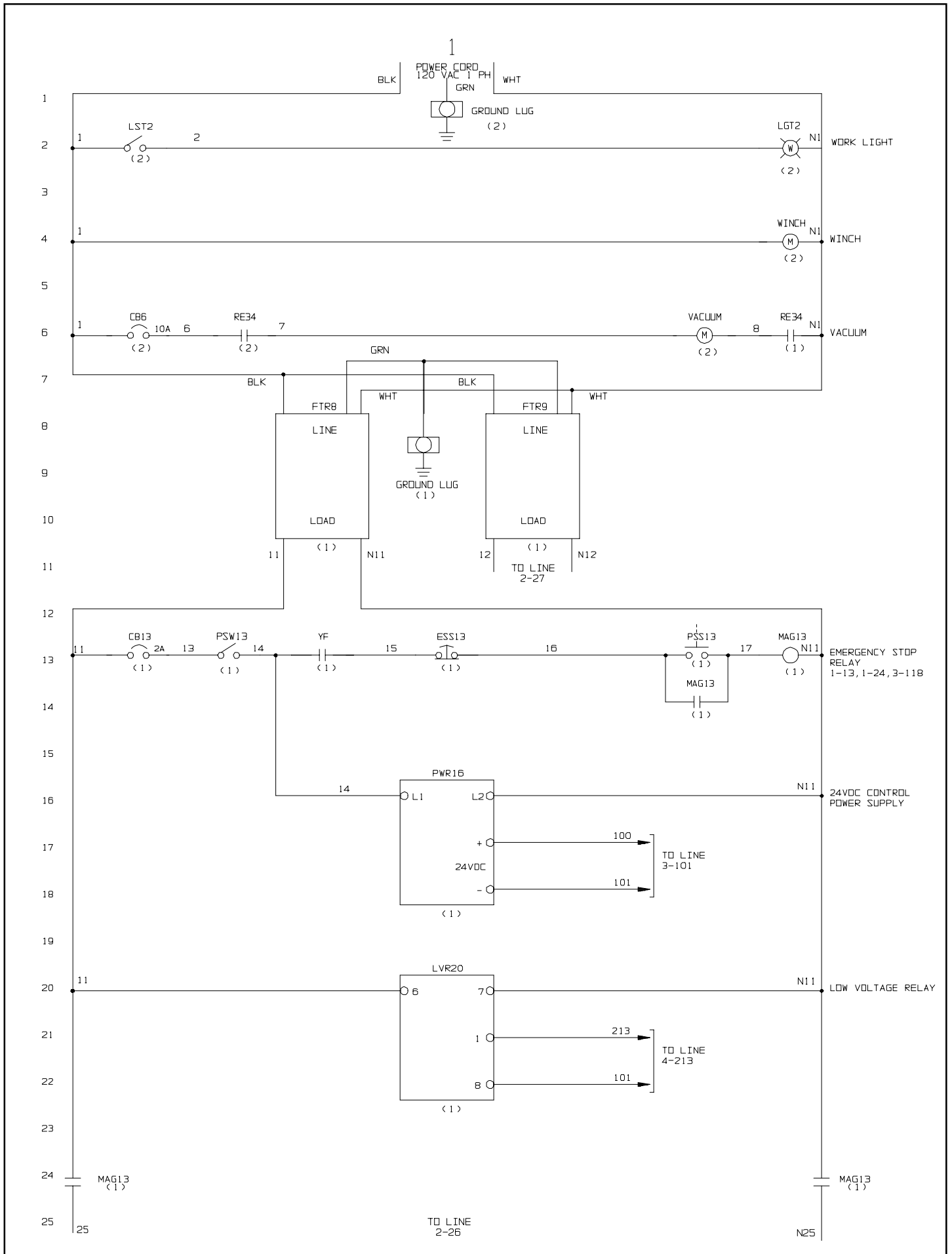

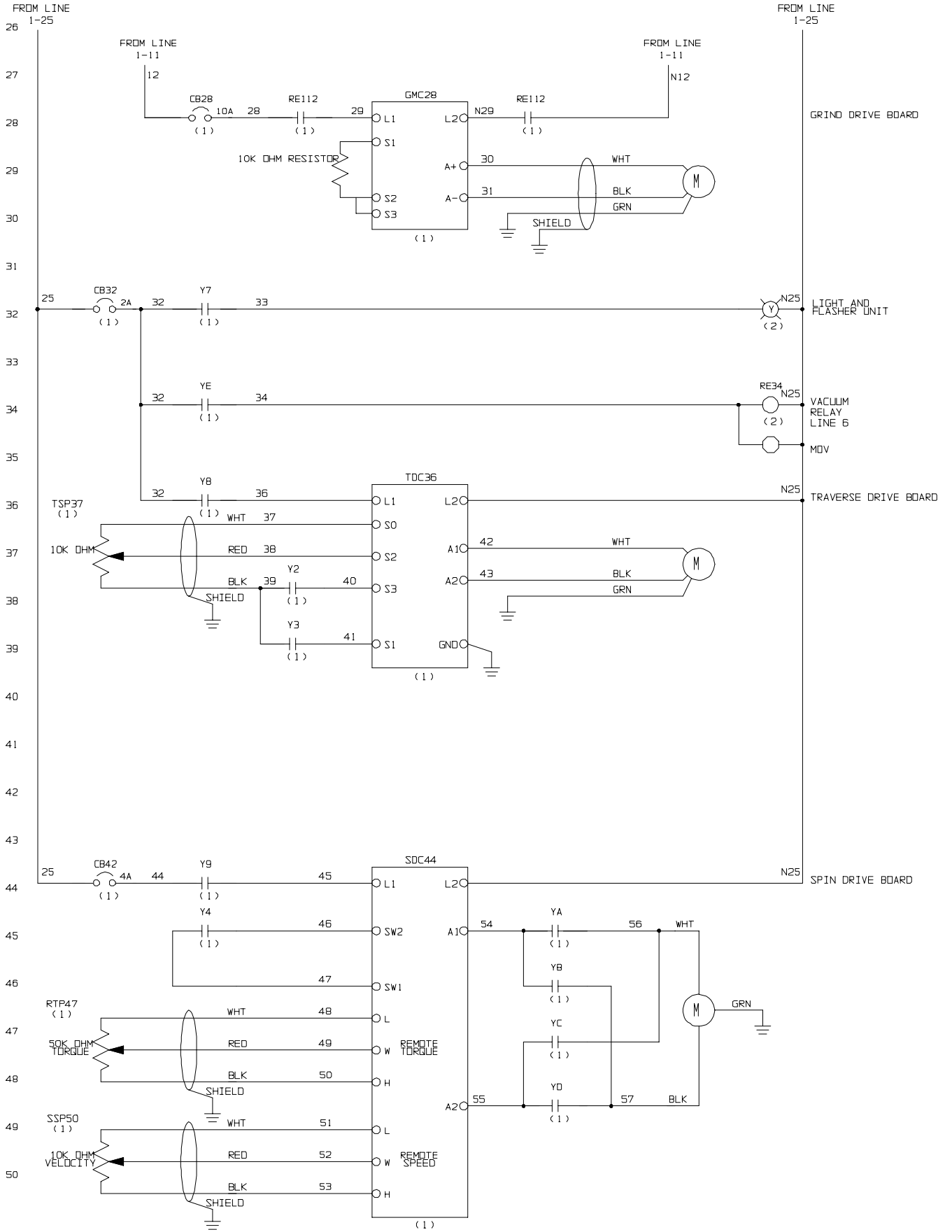

3

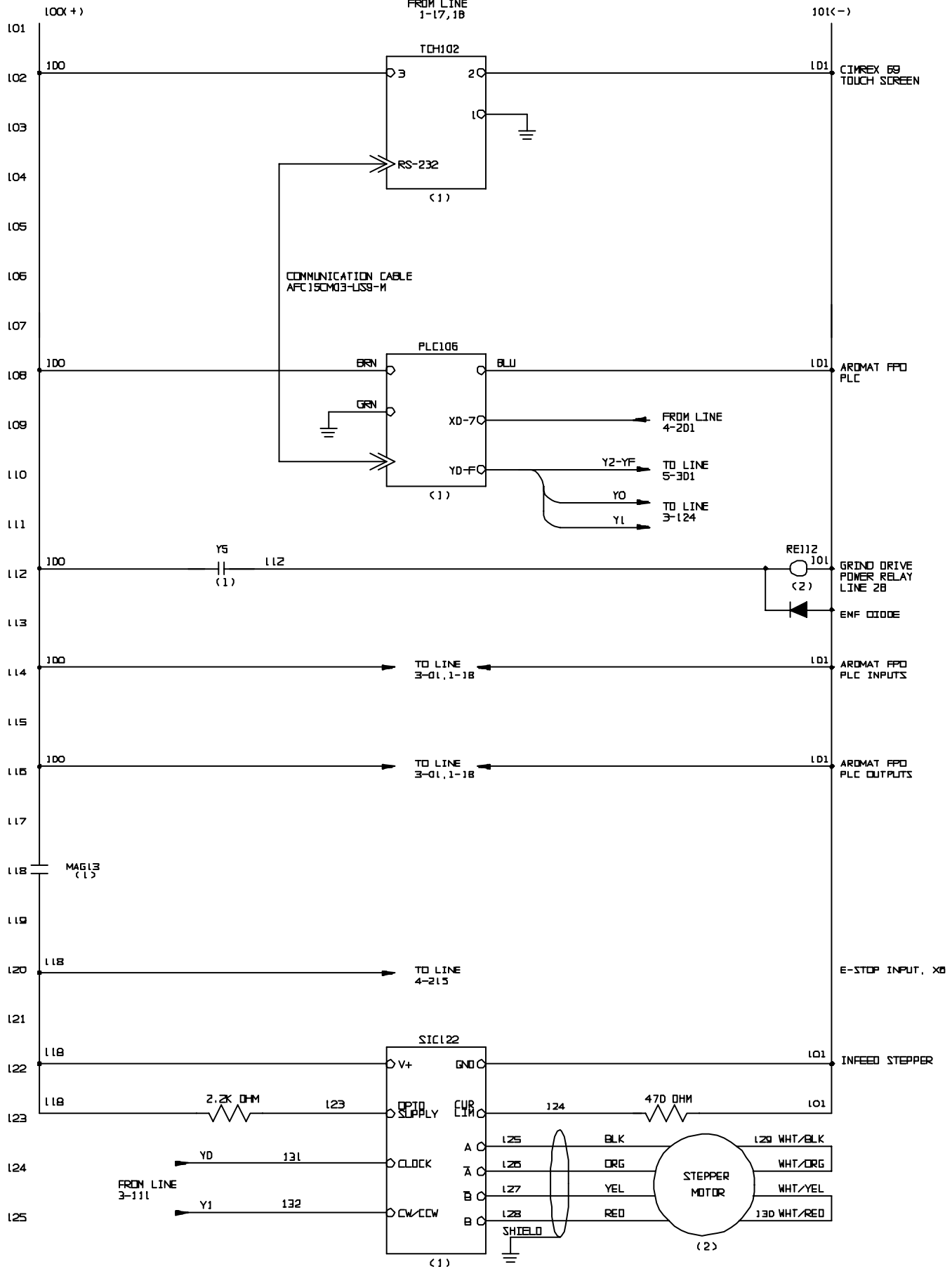

FROM LINE
3-114

100X (+)

101 (-)

PLC INPUTS
TERMINAL BLOCKS

TO LINE
3-108

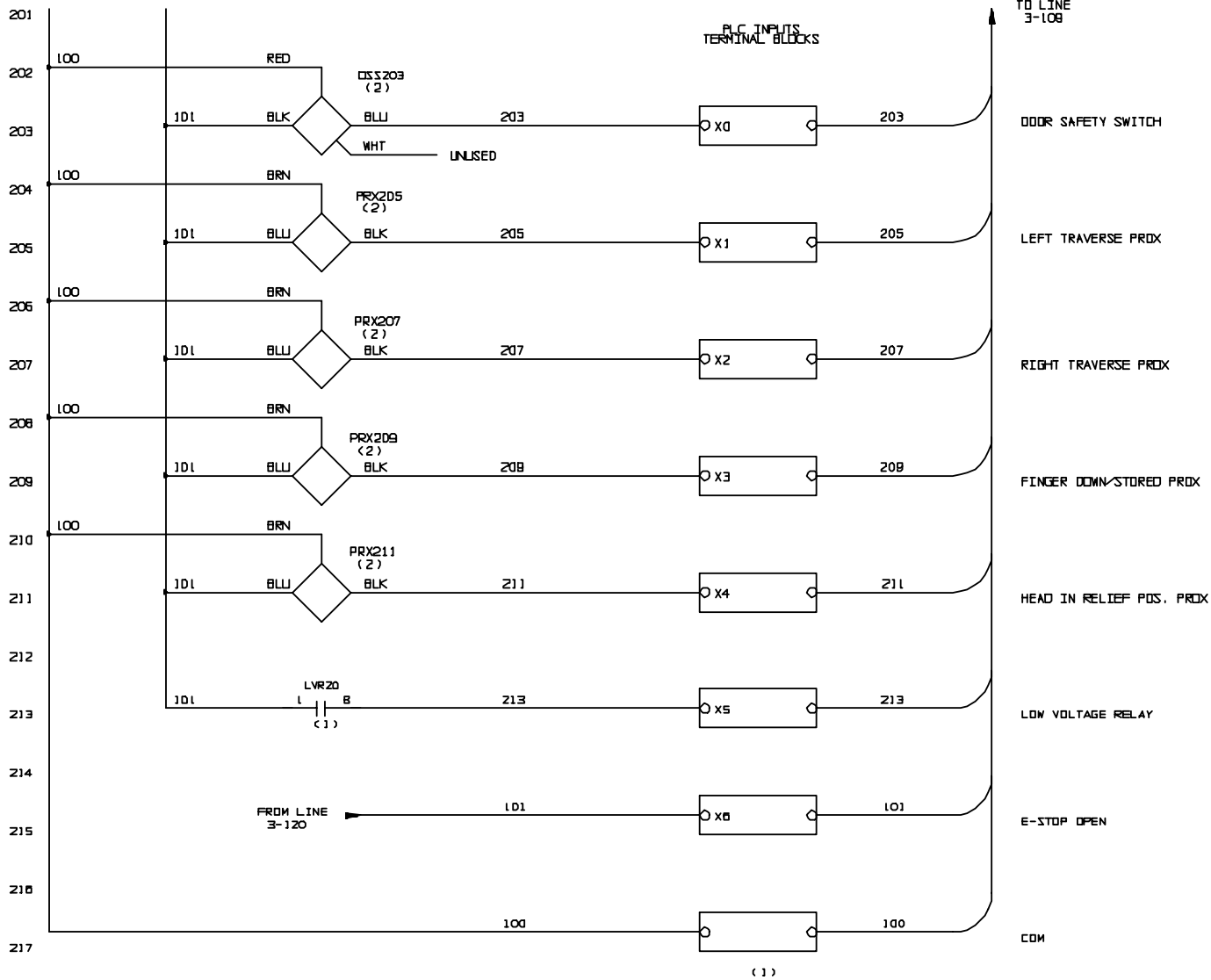

201
202
203
204
205
206
207
208
209
210
211
212
213
214
215
216
217
218
219
220
221
222
223
224
225

5

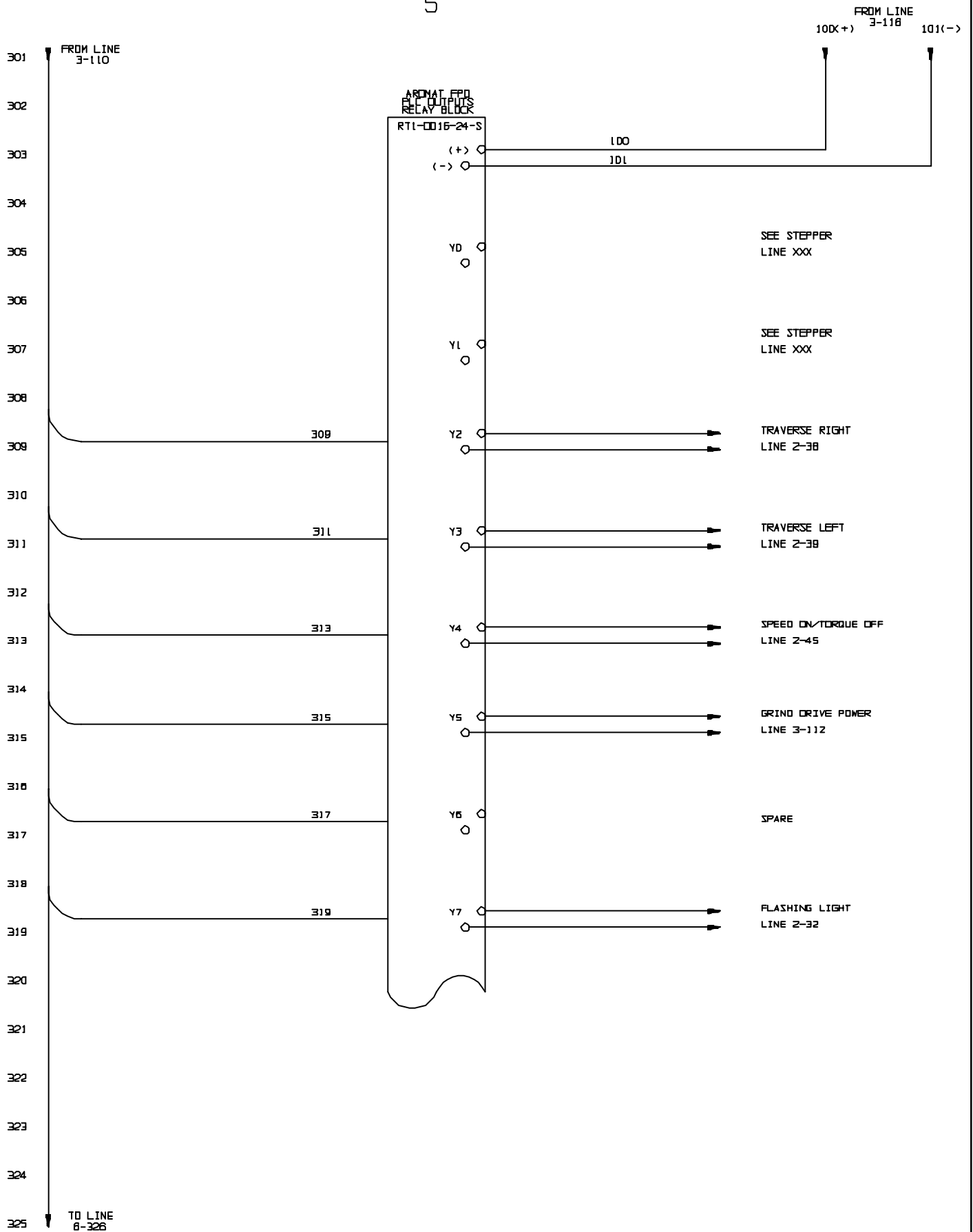

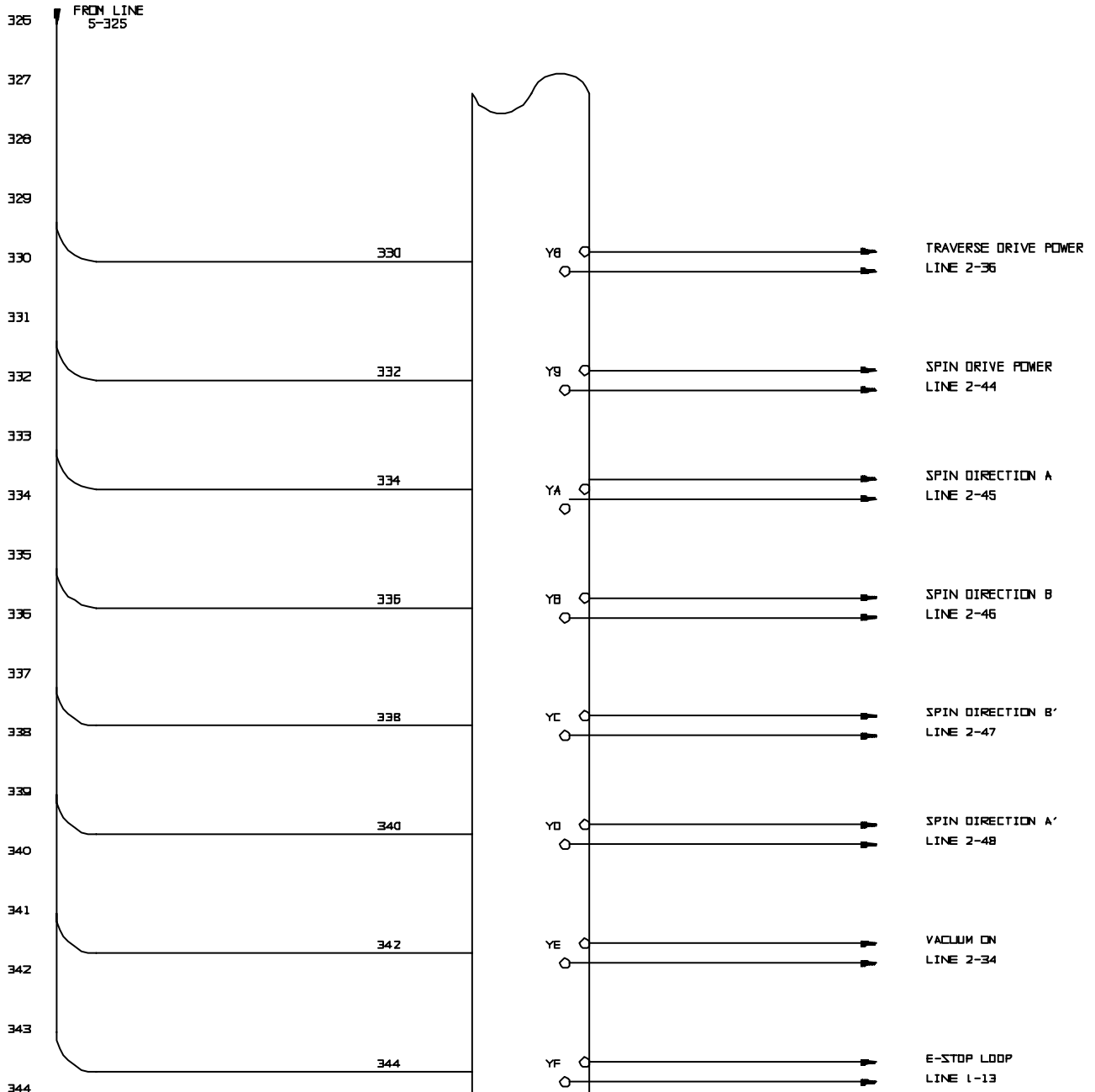

(1)

326
327
328
329
330
331
332
333
334
335
336
337
338
339
340
341
342
343
344
345
346
347
348
349
350

