

ACCU-Pro 630 SPIN/RELIEF GRINDER

ASSEMBLY and SERVICE MANUAL



WARNING

You must thoroughly read and understand this manual before operating the equipment, paying particular attention to the Warning & Safety instructions.

SAFETY INSTRUCTIONS



Safety Awareness Symbols are inserted into this manual to alert you to possible **Safety Hazards**. Whenever you see these symbols, follow their instructions.



The **Warning Symbol** identifies special instructions or procedures which, if not correctly followed, could result in personal injury.

The **Caution Symbol** identifies special instructions or procedures which, if not strictly observed, could result in damage to or destruction of equipment.

1. **KEEP GUARDS IN PLACE** and in working order.
2. **REMOVE WRENCHES AND OTHER TOOLS.**
3. **KEEP WORK AREA CLEAN.**
4. **DON'T USE IN DANGEROUS ENVIRONMENT.**
Don't use Grinder in damp or wet locations. Machine is for indoor use only. Keep work area well lit.
5. **KEEP ALL VISITORS AWAY.** All visitors should be kept a safe distance from work area.
6. **MAKE WORK AREA CHILD-PROOF** with padlocks or master switches.
7. **DON'T FORCE THE GRINDER.** It will do the job better and safer if used as specified in this manual.
8. **USE THE RIGHT TOOL.** Don't force the Grinder or an attachment to do a job for which it was not designed.
9. **WEAR PROPER APPAREL.** Wear no loose clothing, gloves, neckties, or jewelry which may get caught in moving parts. Nonslip foot wear is recommended. Wear protective hair covering to contain long hair.
10. **ALWAYS USE SAFETY GLASSES.**
11. **SECURE YOUR WORK.** Make certain that the cutting unit is securely fastened with the clamps provided before operating.
12. **DON'T OVERREACH.** Keep proper footing and balance at all times.
13. **MAINTAIN GRINDER WITH CARE.** Follow instructions in Service Manual for lubrication and preventive maintenance.
14. **DISCONNECT POWER BEFORE SERVICING,** or when changing the grinding wheel.
15. **REDUCE THE RISK OF UNINTENTIONAL STARTING.** Make sure the switch is OFF before plugging in the Grinder.
16. **USE RECOMMENDED ACCESSORIES.** Consult the manual for recommended accessories. Using improper accessories may cause risk of personal injury.
17. **CHECK DAMAGED PARTS.** A guard or other part that is damaged or will not perform its intended function should be properly repaired or replaced.
18. **KNOW YOUR EQUIPMENT.** Read this manual carefully. Learn its application and limitations as well as specific potential hazards.
19. **KEEP ALL SAFETY DECALS CLEAN AND LEGIBLE.** If safety decals become damaged or illegible for any reason, replace immediately. Refer to replacement parts illustration in Service Manual for the proper location and part numbers of safety decals.
20. **DO NOT OPERATE THE GRINDER WHEN UNDER THE INFLUENCE OF DRUGS, ALCOHOL OR MEDICATION.**

SAFETY INSTRUCTIONS



IMPROPER USE OF GRINDING WHEEL MAY CAUSE BREAKAGE AND SERIOUS INJURY

Grinding is a safe operation if the few basic rules listed below are followed. These rules are based on material contained in the ANSI B7.1 Safety Code for "Use, Care and Protection of Abrasive Wheels". For your safety, we suggest you benefit from the experience of others and carefully follow these rules.

DO

1. **DO** always **HANDLE AND STORE** wheels in a **CAREFUL** manner.
2. **DO VISUALLY INSPECT** all wheels before mounting for possible damage.
3. **DO CHECK MACHINE SPEED** against the established maximum safe operating speed.
4. **DO CHECK MOUNTING FLANGES** for equal and correct diameter.
5. **DO USE MOUNTING BLOTTERS** when supplied with wheels.
6. **DO** be sure **WORK REST** is properly adjusted.
7. **DO** always **USE A SAFETY GUARD COVERING** at least one-half of the grinding wheel.
8. **DO** allow **NEWLY MOUNTED WHEELS** to run at operating speed, with guard in place, for at least one minute before grinding.
9. **DO** always **WEAR SAFETY GLASSES** or some type of eye protection when grinding.

DON'T

1. **DON'T** use a cracked wheel or one that has become damaged.
2. **DON'T FORCE** a wheel onto the machine **OR ALTER** the size of the mounting hole - if wheel won't fit the machine, get one that will.
3. **DON'T** ever **EXCEED MAXIMUM OPERATING SPEED** established for the wheel.
4. **DON'T** use mounting flanges on which the bearing surfaces **ARE NOT CLEAN, FLAT AND FREE OF BURRS**.
5. **DON'T TIGHTEN** the mounting nut excessively.
6. **DON'T** grind on the **SIDE OF THE WHEEL** (see Safety Code B7. 2 for exception).
7. **DON'T** start the machine until the **WHEEL GUARD IS IN PLACE**.
8. **DON'T JAM** work into the wheel.
9. **DON'T STAND DIRECTLY IN FRONT** of a grinding wheel whenever a grinder is started.
10. **DON'T FORCE GRINDING** so that motor slows noticeably or work gets hot.



AVOID INHALATION OF DUST generated by grinding and cutting operations. Exposure to dust may cause respiratory ailments. Use approved NIOSH or MSHA respirators, safety glasses or face shields, and protective clothing. Provide adequate ventilation to eliminate dust, or maintain dust level below the Threshold Limit Value for nuisance dust as classified by OSHA.

This machine is intended for grinding the reel of reel type mower units ONLY. Any use other than this may cause personal injury and void the warranty.



To assure the quality and safety of your machine and to maintain the warranty, you **MUST** use original equipment manufacturers replacement parts and have any repair work done by a qualified professional.

ALL operators of this equipment must be thoroughly trained **BEFORE** operating the equipment.

Do not use compressed air to clean grinding dust from the machine. This dust can cause personal injury as well as damage to the grinder. Machine is for indoor use only. Do not use a power washer to clean the machine.



Low Voltage Relay

The grinder is equipped with a low voltage relay which is factory preset at 100 VAC. If the power supply line does not deliver 100 VAC power under load, the relay will open and trip out the starter. If this occurs, your power supply line is inadequate and must be correct before proceeding further with the grinder.

CONTENTS

Safety Warnings	Page 2- 4
Service Data	Page 5
Assembly Instructions	Page 6 -11
Maintenance Instructions	Page 12 -15
Adjustments	Page 16 -23
Machine Service	Page 24 -27
Electrical Troubleshooting Index	Page 28
Electrical Troubleshooting	Page 29 -45
Mechanical Troubleshooting	Page 46 -47
Parts List	Page 48 -75
Electrical Diagrams	Page 76 -81

SPECIFICATIONS

Electrical Requirements	115V 50/60 Hz, 15 amp circuit
Net Weight	1240 lbs (560 kg)
Shipping Weight	1400 lbs (636 kg)
Maximum Grinding Length	34 inches (86cm)

SERVICE DATA

SKILL AND TRAINING REQUIRED FOR SERVICING

This Service Manual is designed for technicians who have the necessary mechanical and electrical knowledge and skills to reliably test and repair the ACCU-PRO Spin/Relief Grinder. For those without the background, service can be arranged through your local distributor.

This Manual presumes that you are already familiar with the normal operation of the Grinder. If not, you should read the Operators Manual, or do the servicing in conjunction with someone who is familiar with its operation.

Persons without the necessary knowledge and skills should not remove the control box cover or attempt any internal troubleshooting, adjustments, or parts replacement.

If you have questions not answered in this manual, please call your distributor. They will contact the manufacturer if necessary.

TORQUE REQUIREMENTS

Throughout this manual we refer to torque requirements as "firmly tighten" or the like. For more specific torque values, refer to the information below.

Bolts Going Into a Nut, or Into a Thread Hole in Steel.

Refer to the table at the right.

Bolts Going Into a Thread Hole In Aluminum

Use the Grade 2 values in the table at the right.

Socket-Head Screws Going Into a Nut or Steel



Use the Grade 8 values in the table at the right.

Machine Screws

No. 6 screws: 11 in.- lbs (0.125kg - m)

No. 8 screws: 20 in. - lbs (0.23 kg - m)

No. 10 screws: 32 in. - lbs (0.37 kg - m)

	GRADE 2  SMOOTH HEAD	GRADE 5  3 MARKS on HEAD	GRADE 8  6 MARKS on HEAD
1/4 In. thread	6 ft-lbs (0.8 kg-m)	9 ft-lbs (1.25 kg-m)	13 ft-lbs (1.8 kg-m)
5/16 In. thread	11 ft-lbs (1.5 kg-m)	18 ft-lbs (2.5 kg-m)	28 ft-lbs (3.9 kg-m)
3/8 In. thread	19 ft-lbs (2.6 kg-m)	31 ft-lbs (4.3 kg-m)	46 ft-lbs (6.4 kg-m)
7/16 In. thread	30 ft-lbs (4.1 kg-m)	50 ft-lbs (6.9 kg-m)	75 ft-lbs (10.4 kg-m)
1/2 In. thread	45 ft-lbs (6.2 kg-m)	75 ft-lbs (10.4 kg-m)	115 ft-lbs (15.9 kg-m)

ASSEMBLY INSTRUCTIONS

Remove the sides, front, and back of the crate. Remove the plastic bag, shrink wrap and bubble wrap around boom assembly. Remove the metal clips that secure the grinder to the crate base. With a fork lift, raise the grinder from the wood base and set it in its final position. See FIG. 1 and 2.



THE UNIT WEIGHS 1240 LBS. (560 kg). TO LIFT, USE POWER EQUIPMENT.

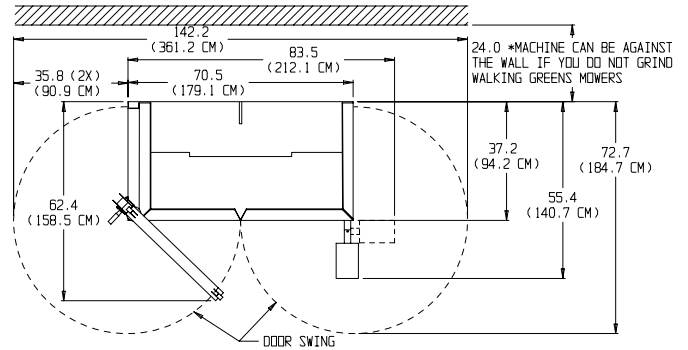

FIG. 1

Remove shipping straps from traverse carriage. Remove window protective sheets.

POSITION BASE

The ACCU-Pro Spin/Relief Grinder will require an operating area of about 150" W x 108" D x 87" H (381 x 274 x 221 cm). The mower reel will be lifted from the front of the machine. The machine operator will operate the unit from this same position. Position the base to allow sufficient operating room in front of the machine. See FIG. 1 and 2.

The base should be placed on a relatively level concrete floor, with ample ceiling height to allow for the installation of the unit. Do not place the unit across two concrete slab seams or across a large crack.

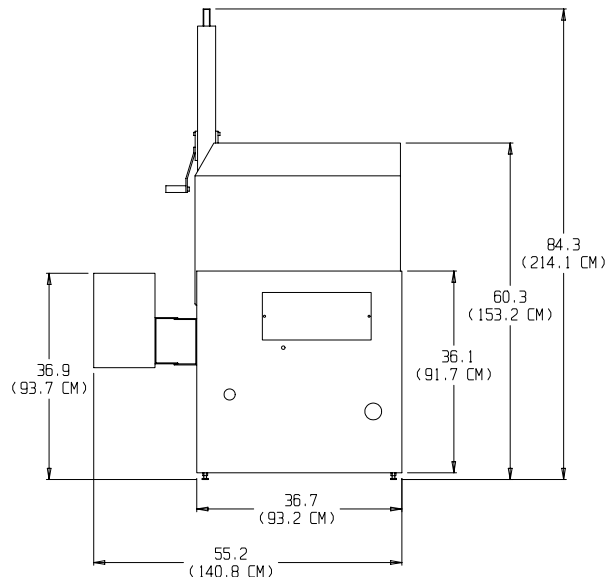
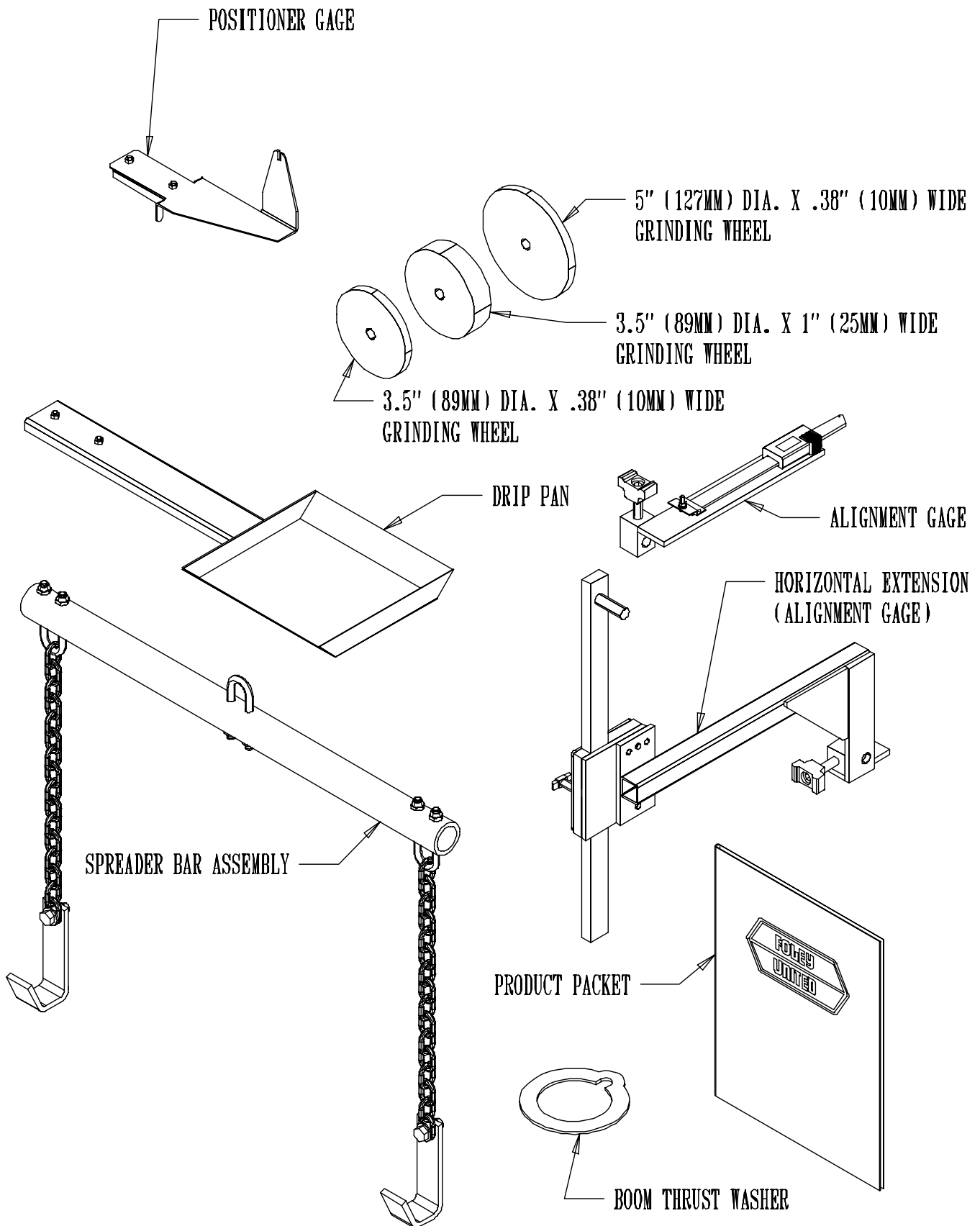

FIG. 2

ASSEMBLY INSTRUCTIONS (Continued)

Remove the carton and remove the contents from the carton onto a workbench. The carton includes:



ASSEMBLY INSTRUCTIONS (Continued)

LEVEL BASE

Each leveling foot has been factory pre-adjusted so it protrudes from the base 1 3/4" (57 mm). See FIG. 3. Place level on the top of the table and check the levelness of the unit from side to side. Adjust the leveling feet as necessary to bring to level. See FIG. 4.

Place a level across the table from front to rear. Adjust the leveling feet on the end of the machine as necessary to level. See FIG. 5

When both front to back and side to side leveling procedures have been completed, thread the hex jam nuts up against the nut that is welded to the bottom until they lock into place. Be careful not to move the leveling feet during this process. See FIG. 3. Make certain that all four leveling feet are firmly contacting the floor.

Recheck with level after locking nuts are firmly tightened.

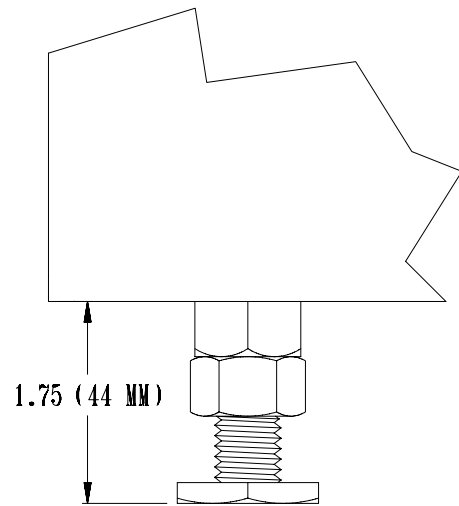

FIG. 3

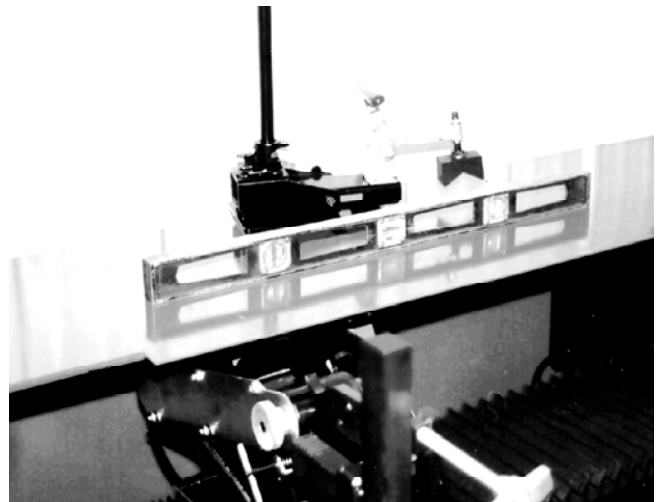

FIG. 4

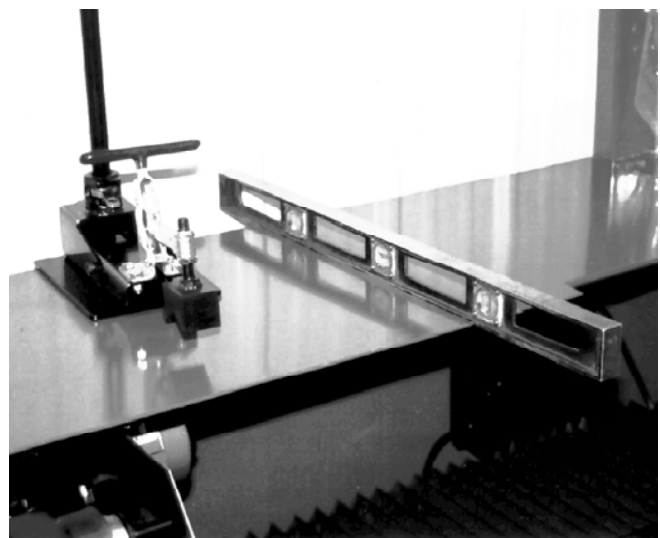

FIG. 5

STORAGE PROCEDURE

It is important to follow the procedures below when placing your grinding in storage for an extended period of time. Proper care will help maintain the working functions of the grinder and decrease maintenance and problems that occur when storing the grinder.

BEFORE STORING THE GRINDER:

-Clean the machine thoroughly. (Do not use compressed air or a power washer to clean this machine!) See Maintenance section for instructions on cleaning polycarbonate.

-Lubricate the following parts by flooding the area with a spray lubricant and leaving it in place: (Do not use a Teflon based lubricant)

 Traverse shafts, linear bearings and drive shaft (see Lubrication section of manual)
 Remove grinding wheel and spray the movable parts of the finger system
 Cross slide shafts and adjustment screws (Right side of Traverse Base)
 Scratches in the paint or any other bare metal surfaces

-Work the lubricant in by moving parts through their full range of motion.

-Make sure all controls are in the off position and unplug the unit from the wall. Turn off the digital alignment gage.

-Cover the unit if possible with a sheet or tarp.

BRINGING THE UNIT BACK INTO SERVICE:

-Remove the cover and reapply lubricant to the items stated above. Wipe off all excess lubricant. (See Lubrication section for more details.)

-Plug the unit into the wall and test all electrical functions.

-Check the belt for cracking and adjust the tension if necessary.

-Check for damaged or missing parts.

ASSEMBLY INSTRUCTIONS (Continued)

APPLY POWER



BEFORE YOU APPLY POWER TO THE GRINDER, REFER TO THE "IMPORTANT GROUNDING INSTRUCTIONS" ON PAGE 9.

115 Volt Model Only. Plug the control box power cord into a standard 115V AC 15-amp grounded receptacle. See FIG. 7.

220 Volt Model Only. For 220 Volt Applications order Part No. 6300951, which includes a prewired 2 KVA 220 V step down to 115V 50-60 Hz transformer. See details on Page 11.



FIG. 7

IT IS RECOMMENDED THAT THIS ACCU-PRO SPIN/RELIEF GRINDER HAS ITS OWN PERMANENT POWER CONNECTION FROM THE POWER DISTRIBUTION PANEL, WITH NO OTHER MAJOR POWER DRAW EQUIPMENT ON THE SAME LINE.

The grinder is equipped with a low voltage relay which is factory preset at 100 VAC. If the power supply line does not deliver 100 VAC power under load, the relay will open and trip out the starter. If this occurs, your power supply line is inadequate and must be correct before proceeding further with the grinder.



IT IS REQUIRED THAT THE POWER DELIVERED TO THIS GRINDER IS 115 VAC - 15 AMPS. THE TOLERANCE ON THIS POWER REQUIREMENT IS +/- 5%. THEREFORE THE MINIMUM VOLTAGE REQUIREMENT IS 109VAC WITH 15 AMPS. VOLTAGE MUST BE CHECKED WITH ALL EQUIPMENT UNDER LOAD (OPERATING) ON THE CIRCUIT.

DO NOT OPERATE THIS GRINDER WITH AN EXTENSION CORD.



PROPER GROUNDING OF THE RECEPTACLE GROUND IN YOUR BUILDING MUST BE VERIFIED. IMPROPER GROUNDING IN YOUR BUILDING MAY CAUSE THE GRINDER TO MALFUNCTION.



FOR 15 AMP RATED LARGE MACHINES

Below is a list of required wire size in your building.

For 0 to 30 Feet from panel to receptacle = Use 14 Ga. Wire.
For 30 to 50 Feet from panel to receptacle = Use 12 Ga. Wire.
For 50 to 80 Feet from panel to receptacle = Use 10 Ga. Wire.
For 80 to 140 Feet from panel to receptacle = Use 8 Ga. Wire.

For 0 to 15 Meters from panel to receptacle = Use 2.5mm Wire.
For 15 to 42 Meters from panel to receptacle = Use 4.0mm Wire.

ASSEMBLY INSTRUCTIONS (Continued)

FOR 220 V 50 or 60Hz applications Product No. 6300951 should be ordered.

6300951 includes a 2 KVA 220V, step down to 115 V 50-60 Hz transformer should be ordered.

The wiring diagram is shown in FIG. 8.

The power cord has no connector. A connector which is appropriate for your locality and 220 volt, 8 amp application should be installed.

! Use only a qualified electrician to complete the installation.

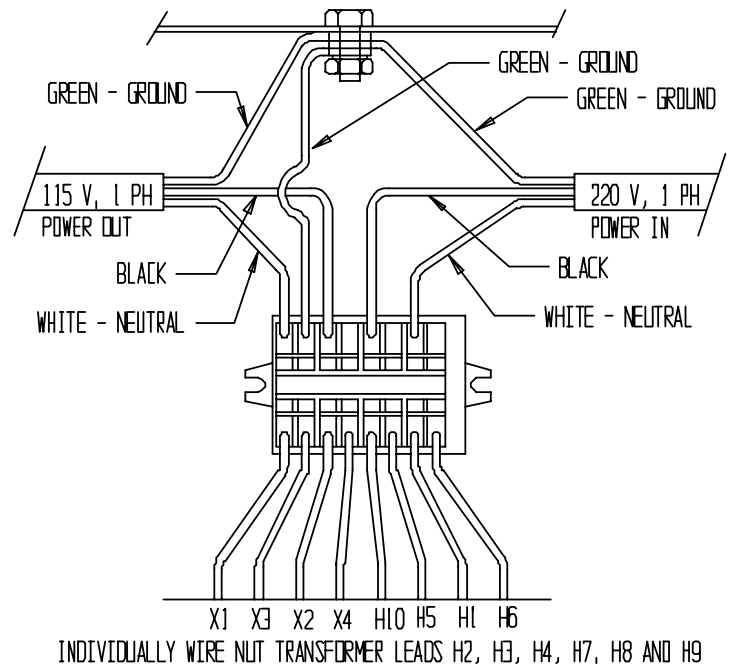

FIG. 8

IMPORTANT GROUNDING INSTRUCTIONS

In case of a malfunction or breakdown, grounding reduces the risk of electrical shock by providing a path of least resistance for electrical current.

This Grinder has an electrical cord with an equipment grounding conductor and a grounding plug. The plug must be plugged into a matching outlet that is properly installed and grounded according to all local or other appropriate electrical codes and ordinances.

Before plugging in the Grinder, make sure it will be connected to a supply circuit protected by a properly-sized circuit breaker or fuse.

Never modify the plug provided with the machine--if it won't fit the outlet, have a proper outlet and circuit installed by a qualified electrician.



ALWAYS PROVIDE A PROPER ELECTRICAL GROUND FOR YOUR MACHINE. AN IMPROPER CONNECTION CAN CAUSE A DANGEROUS ELECTRICAL SHOCK. IF YOU ARE UNSURE OF THE PROPER ELECTRICAL GROUNDING PROCEDURE, CONTACT A QUALIFIED ELECTRICIAN.

PERIODIC MAINTENANCE

DAILY MAINTENANCE IS SPECIFIED ON PAGE 4 OF THE OPERATOR'S MANUAL, AND IS TO BE PERFORMED BY THE OPERATOR. LISTED BELOW ARE PERIODIC MAINTENANCE ITEMS TO BE PERFORMED BY YOUR COMPANY'S MAINTENANCE DEPARTMENT:

1. Clean the internal bag and cloth filter in the vacuum system weekly or more often depending on the number of reels ground. (Vacuum system is optional equipment).
2. Use the grease fitting provided to grease the dove tail with high quality lithium grease monthly. Wipe off excess grease. See FIG. 7.
3. Wipe and re-oil with spray lubricant, the grinding wheel diameter adjusting lead screw every three months. Wipe off all excess lubricant. See FIG. 7.
4. Check the gib adjustment on the Grinding wheel diameter adjustment every 3 months. See FIG. 7.
5. Inspect the Poly-V belt for cracking and adjust the belt tension per procedure called out in the adjustment section every three months.
6. Wipe and relube with never-seez, the vertical and horizontal alignment shafts and lead screws, every six months. See FIG. 8.
7. Lift the bellows and wipe off the traverse driveshaft and the bearing rails monthly. When a squeaking noise is coming from the actuator bearings, follow the lubrication procedure for actuator and linear bearings. Generally, this will be every six months to a year.

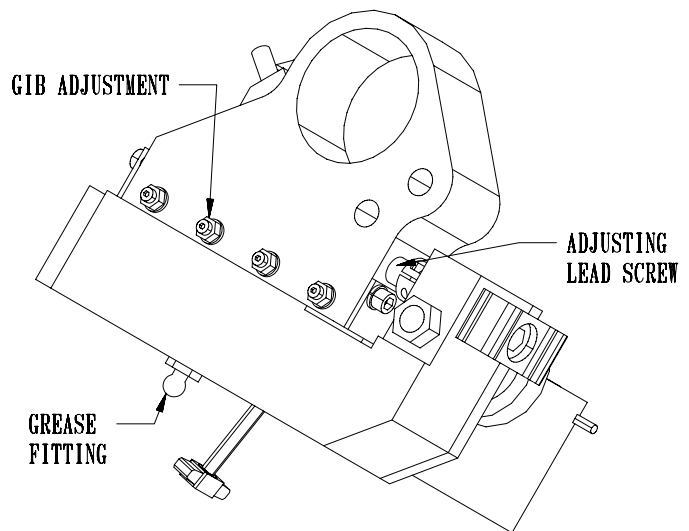

FIG. 7

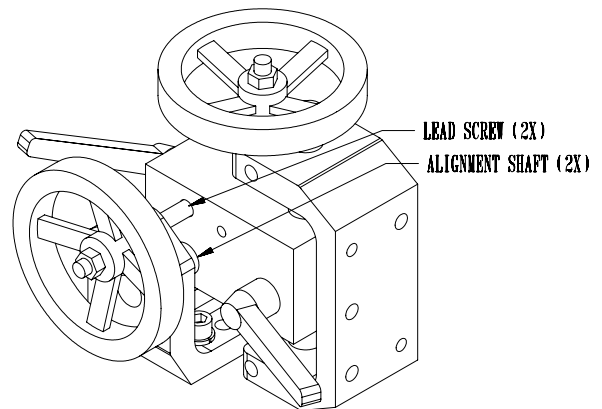

FIG. 8

LUBRICATION

LUBRICATION OF ACTUATOR AND LINEAR BEARINGS

STEP 1--Thoroughly clean all three shafts.

STEP 2--Flood spray all three shafts with a spray lubricant (do not use a teflon based lubricant) until the lubricant is dripping off the shafts. See FIG. 10 Then run the carriage back and forth through its range of travel. This will carry the lubricant into the actuator and bearings.

NOTE: Because of the flood of lubricant you may find that the actuator slips and traversing is erratic or stalls. This is not a problem as it will be corrected in the subsequent steps.

STEP 3--With a clean rag, wipe off the excess amount of lubricant from the shafts. Run the carriage back and forth through its range of travel and wipe the shafts after each traverse. Repeat until the shafts are dry to the feel. This completes the lubrication process.

If the unit will be shut down for an extended period of time, more than four weeks, then the shafts and other appropriate parts of the unit should be flooded with lubricant and that lubricant left in place until the unit is brought back into service. When the unit is brought back into service the full lubrication procedure as stated above should be repeated.

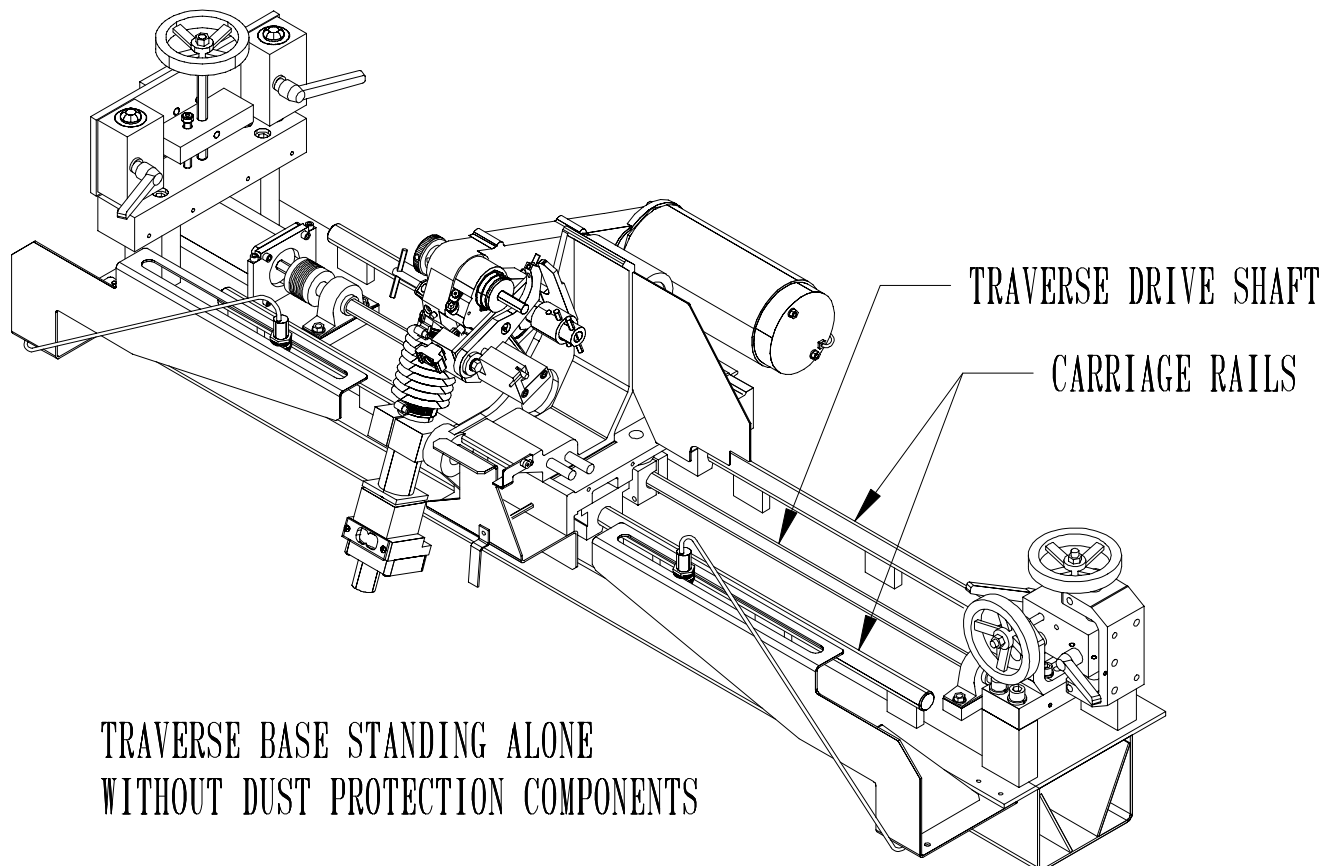

FIG. 10

MAINTENANCE (Continued)

CLEANING AND MAINTENANCE GUIDELINES FOR POLYCARBONATE WINDOWS

Cleaning Instructions



DO NOT USE GASOLINE

Adherence to regular and proper cleaning procedures is recommended to preserve appearance and performance.

Washing to Minimize Scratching

Wash polycarbonate windows with a mild, liquid dish washing detergent and lukewarm water, using a clean, soft sponge or a soft cloth. Rinse well with clean water. Dry thoroughly with a moist cellulose sponge to prevent water spots. Do not scrub or use brushes on these windows. Also do not use butyl cellosolve in direct sunlight. Fresh paint splashes and grease can be removed easily before drying by rubbing lightly with a food grade VM&P naphtha or isopropyl alcohol. Afterward, a warm final wash should be made, using mild, liquid dish washing detergent solution and ending with a thorough rinsing with clean water.

Minimizing Hairline Scratches

Scratches and minor abrasions can be minimized by using a mild automobile polish. Three such products that tend to polish and fill scratches are Johnson Paste Wax, Novus Plastic Polish #1 and #2, and Mirror Glaze plastic polish (M. G. M10). It is suggested that a test be made on a corner of the polycarbonate window with the product selected following the polish manufacturer's instructions.

Some Important "DON'TS"

- tt **DO NOT** use abrasive or highly alkaline cleaners on the polycarbonate windows.
- tt **NEVER** scrape polycarbonate windows with squeegees, razor blades or other sharp instruments.
- t t Benzene, gasoline, acetone or carbon tetrachloride should **NEVER** be used on polycarbonate windows
- t t **DO NOT** clean polycarbonate windows in hot sun or at elevated temperatures.

Graffiti Removal

- t t Butyl cellosolve, (for removal of paints, marking pen inks, lipstick, etc.)
- t t The use of masking tape adhesive tape or lint removal tools works well for lifting off old weathered paints.
- t t To remove labels, stickers, etc., the use of kerosene, VM&P naphtha or petroleum spirits is generally effective. When the solvent will not penetrate sticker material, apply heat (hair dryer) to soften the adhesive and promote removal.
GASOLINE SHOULD NOT BE USED!

MAINTENANCE (Continued)

DIGITAL GAGE

Important

- t t Do not mark the scale unit with and electric engraver or scratch the scale.
- t t **Always use an SR44 battery (silver oxide cell)**
- t t If the scale will not be used for more than three months, remove the battery and store it properly. Otherwise, leakage, if any, from the battery may damage the unit.

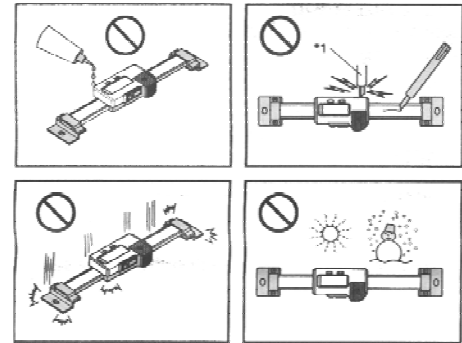

Description of Parts

- | | |
|------------------------|--------------------|
| 1. Beam | 2. Main Scale |
| 3. Battery compartment | 4. Outp Connection |
| 5. Display | 6. ON/OFF Power |
| 7. ZERO/ABS switch | 8. Origin Switch |
| 9. Inch/mm Switch | 10. Tapped hole |
| 11. Slider | |

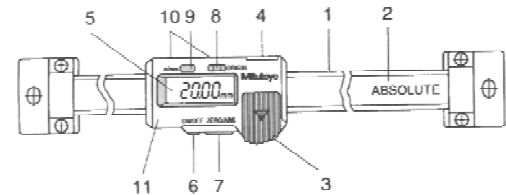

Battery Installation and Origin Setting

Set the origin of the scale after installing the battery. Otherwise, the error sign("E" at the least significant digit) may appear, resulting in incorrect measurements.

- 1) To install the battery, remove the compartment lid and install the SR44 battery with its positive side facing up. After the battery is installed, set the origin.
- 2) To set the origin, move the slider to an area you wish to set as your origin. Turn the power on. Hold the ORIGIN switch down for more than one second. The "0.00" display appears, indicating Origin setting is complete. The origin will be retained even if the power is turned off.

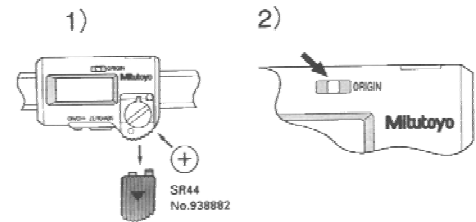

Incremental (INC) & Absolute (ABS) mode

The LCD will display measurements from the origin when turned on (ABS mode). To set the origin see above. The display can be set to zero at any desired position by pressing the ZERO/ABS switch. INC indicator will appear in the display (INC mode), permitting measurements from this zero point. To return to the ABS mode hold the ZERO/ABS button for more than 2 seconds.

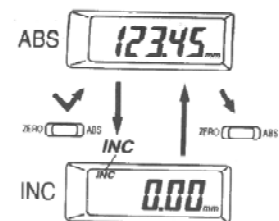

Error Symptoms & Remedies

- t t **ERRC and display flickering:** Occurs when the scale surface is stained. Clean the scale surface and coat a thin film of low viscosity oil to keep out moisture.
- t t **E in the least significant digit:** This occurs when the slider is moved too quickly, but it does not affect the measurement. If it stays on when the slider stops, the scale surface is probably stained. If this is the case, take remedies as for ErrC.
- t t **B indication:** Battery voltage is low. Replace the battery as soon as possible.

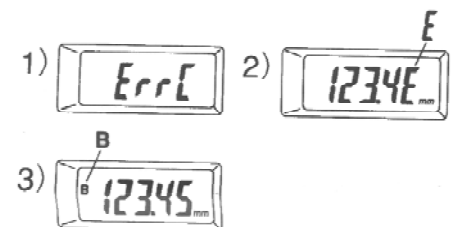

ADJUSTMENTS

LINEAR ACTUATOR BEARING REPLACEMENT

NOTE: It is not necessary to remove the linear actuator from the drive shaft—Remove only the bearings.

STEP 1—Remove the shoulder bolt from the top side of carriage. See FIG. 11.

STEP 2—Turn the actuator release lever 1/2 turn clockwise to release the actuator from the drive shaft. Slide the actuator release lever out of actuator bar assembly by loosening the retainer shaft collar, which preloads the holding spring. See FIG. 12.

STEP 3—Move the grinding head carriage to the left side. Lift the bellows. Remove shoulder bolts fastening the six bearings to the actuator body. See FIG. 13. Remove the old bearings from the shoulder bolt, and discard, saving the inside washer. Insert the shoulder bolts through the new bearings and the saved inside washers. Then install these assemblies into the actuator body and tighten the shoulder bolts.

STEP 4—Slide the carriage over the actuator assembly to line up the hole in the carriage with the tapped hole in the actuator. Insert the shoulder bolt through self aligning bearings and tighten.

NOTE: Take extra caution not to cross thread the shoulder bolt.

STEP 5—Slide actuator release lever with collar, spring washer and foam seal back into actuator bar assembly and lock in place with retainer shaft collar. See FIG.12. Turn actuator release lever 1/2 turn counterclockwise to engage bearings to drive shaft.

STEP 6—Using a spring scale, connect the scale to the carriage to pull on the carriage parallel to actuator drive shaft. Then while holding the drive shaft from rotating, pull on carriage; the pull force should be 60 lbs. (See Step 7 for readjustment if necessary.)

THE PULL FORCE IS TO BE CHECKED WHEN SHAFT IS WIPED CLEAN AND DRY. IF CHECKED WHEN OILY, TOO MUCH TENSION WILL BE SET AND AFFECT BEARING LIFE.

STEP 7—If readjustment is required to achieve pull force within specification, with actuator bearings engaged to drive shaft, readjust the two outboard screws with springs that hold the actuator together. See FIG. 13. To reach these screws, the actuator bar assembly must be removed. Turn each screw an equal amount when resetting for more or less tension, clockwise is more tension. Repeat Step 6 and verify pull force. Continue to adjust until within specification. The factory preadjusted spring tension is .160 or 5/32" (4 mm) from under the washer holding the spring to the actuator block. See FIG. 12. This should give the 60 lbs. carriage pull force specified.

When adjustment is correct reinstall the actuator bar assembly. The bar assembly must be adjusted parallel to the actuator aluminum body and so it is just touching the outboard screw heads. Then tighten the lock nut on the lower actuator bar assembly mounting screw. See FIG. 12. Then reinstall the release lever package as above.

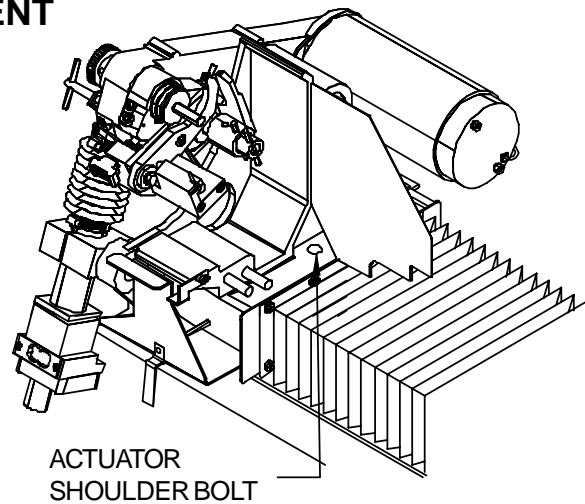

FIG. 11

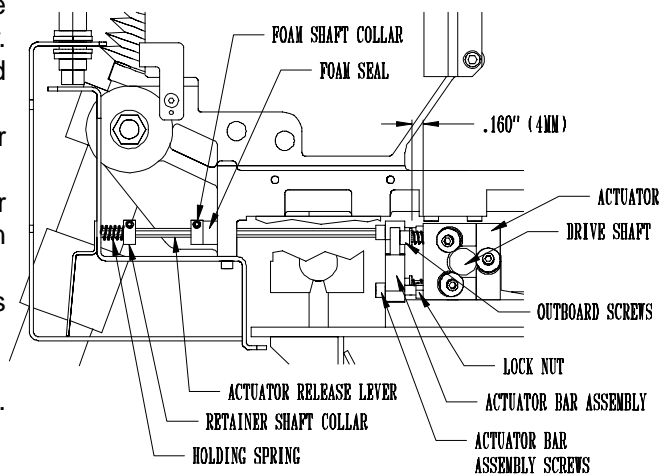

FIG. 12

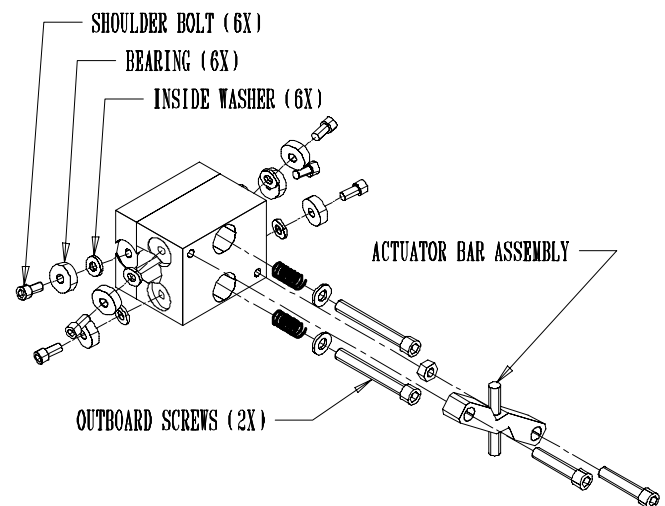

FIG. 13

ADJUSTMENTS (Continued)

CARRIAGE LINEAR BEARING REPLACEMENT

STEP 1--Detach the bellows mounting brackets from the carriage. Detach front and rear shields. See FIG. 15.

STEP 2--Remove the three screws of one linear bearing and slide the linear bearing off the end of the carriage shaft.

STEP 3--Insert a new linear bearing onto the end of the carriage shaft with the tension adjustment screw pointing outward. See FIG. 14. Adjust the tension screw of the linear bearing so when you radially rotate the linear bearing around the carriage shaft there should be no free play between the linear bearing and the carriage shaft.

NOTE: Tension is too tight if you feel a cogging action when you rotate the linear bearing around the shaft. This cogging is from the skidding of the bearing on the shaft and indicates tension screw is too tight.

Finally, sliding the bearing block back and forth should be a smooth uniform motion.

! SETTING THE BEARING TENSION CORRECTLY IS CRITICAL TO PROPER GRINDING. BEARINGS WHICH ARE TOO TIGHT OR TOO LOOSE WILL CAUSE POOR GRIND QUALITY. ALSO, BEARINGS WHICH ARE TOO TIGHT WILL HAVE SUBSTANTIALLY SHORTER LIVES AND MAY DAMAGE THE SHAFT.

STEP 4--Slide linear bearing under carriage and attach with the three screws.

NOTE: Repeat Steps 2 thru 4 with the other three linear bearings.

STEP 5--After all four linear bearings are reattached to the carriage check for correct bearing tension. The bearing tension is correct when you try to lift the carriage and can feel no carriage movement, which is free play up and down. The most dependable method of checking free play is to use a magnetic base dial indicator attached to the traverse frame weldment and reading the vertical movement above each bearing. This movement should be within .001" (.03 mm) Also, when pulling the carriage in the traversing direction, there should be only approximately a 3 lb force, with the actuator disengaged, using a scale system similar to Step 6 of Linear Actuator Bearing Replacement Section in this manual. To double check the assembly, slide the carriage assembly from "end of travel" to "end of travel", it should have very uniform resistance through the full range of travel.

STEP 6--Replace the bellows carriage mounting brackets onto the carriage. Replace front and rear shields. See FIG. 15.

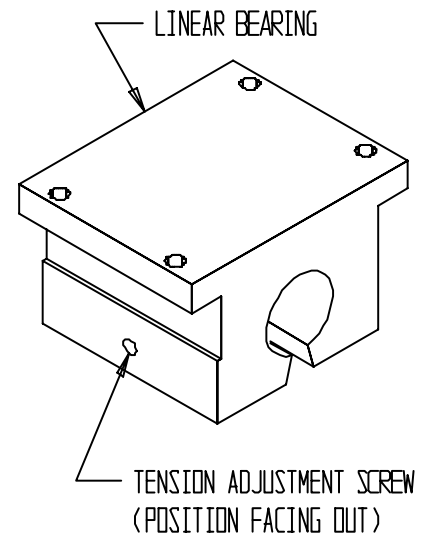

FIG. 14

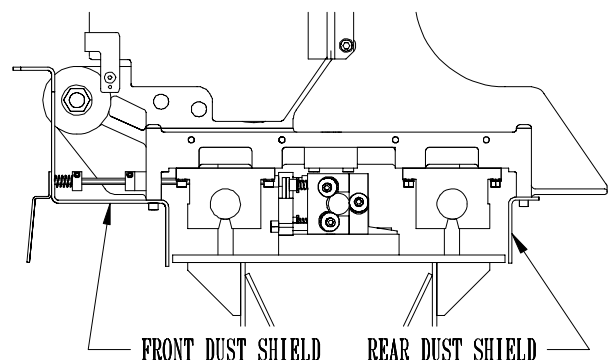

FIG. 15

ADJUSTMENTS (Continued)

REEL FINGER DOVETAIL GIB AND ADJUSTING KNOB ADJUSTMENTS

The reel finger slide to the reel finger positioner has a dovetail with an adjustable gib for tensioning. Tighten the gib set screws on the side so there is no free play in the dovetail slide. Check for movement when pushing on the relief finger side to side with 20 lbs. (44kg) force. Make sure the knob assembly for adjusting the relief finger to the grinding wheel is rotatable by hand. The gib adjustment should be sufficient to maintain a rigid position of the reel finger. See FIG. 16.

Check the knob assembly rotating tension by checking the tightness of the nylon plug to the knob assembly threads. The tightness has to be sufficient so the knob assembly does not rotate during the relief grinding cycle. See FIG. 17.

NOTE: To adjust the nylon plug you must lock the index finger assembly down and then adjust the reel finger positioner so the clearance holes line up with the nylon plug set screw.

Take up any free play between the tee knob assembly, reel finger slide and .375 threaded split shaft collar. Loosen the shaft collar locking cap screw and rotate the shaft collar until there is no end play. Retighten locking cap screw on the threaded split shaft collar. See FIG. 16.

GRINDING HEAD BELT TENSION ADJUSTMENT

The grip grinding wheel knob need not be removed for belt tensioning adjustment. Remove the six socket head cap screws holding, the two double tube clamps and the belt cover. For grinding motor belt adjustment, loosen the four socket head cap screws that attach the motor. Adjust the grinding motor for proper belt tension by pushing back on the motor and tighten the four socket head cap screws. The proper belt tension for the grinding head is to push down on the poly V belt half way between the two pulleys with 5 lbs. (2KG) of force and belt movement dimensions to be .12 inches (3mm). See FIG. 18. To verify belt tension mount the belt guard with two screws. Turn the motor on. If the belt is tensioned correctly, start-up torque of the motor through the pulley to the belt should have zero slippage. If there is belt slippage when turning on the motor there will be a slight squeal before the belt comes up to speed. When you achieve correct tension, reassemble all of the remaining parts that have been removed.

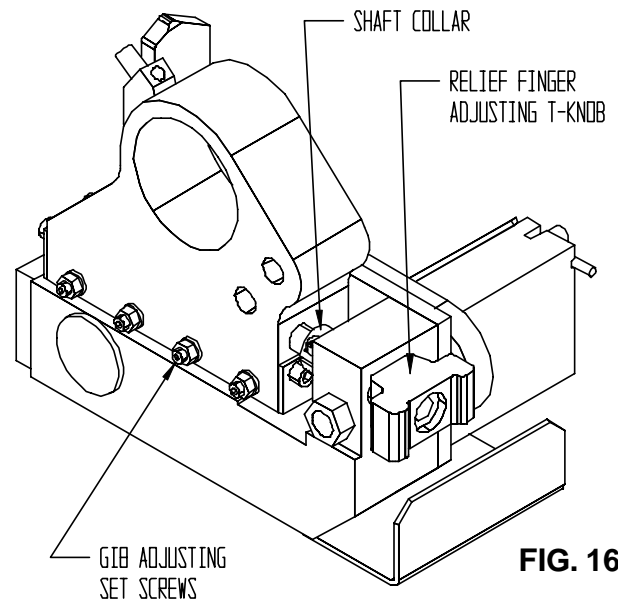

FIG. 16

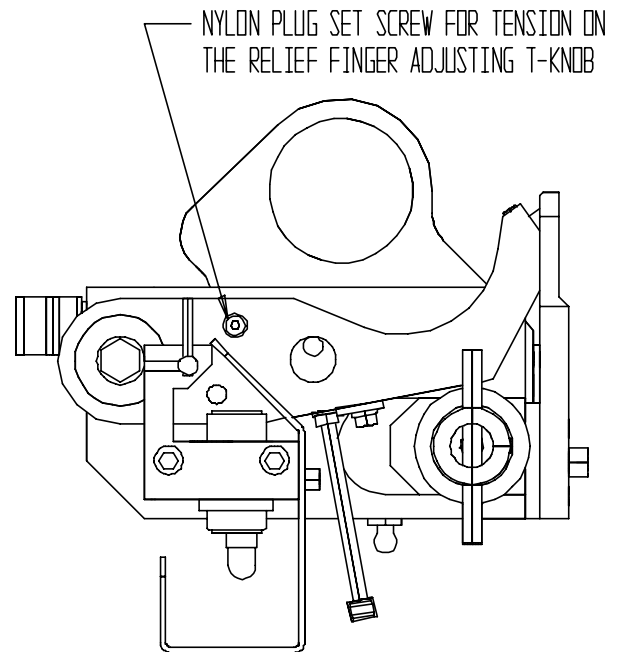

FIG. 17

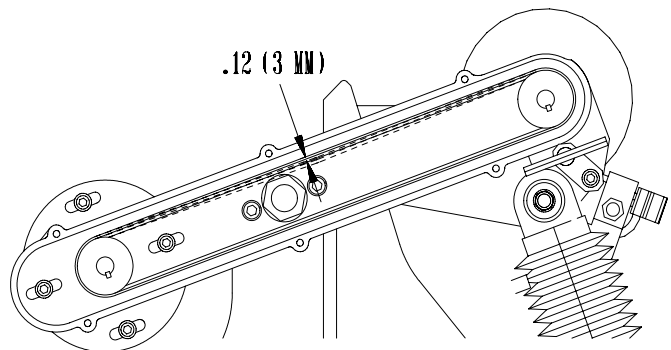

FIG. 18

ADJUSTMENTS (Continued)

LOCKING INDEX FINGER PIN

To align the Index Finger Locking Pin to the hole in the Index Finger Assembly loosen the two socket head cap screws so the index sensor block is movable. Push down on the index finger assembly until the spring loaded index finger locks into hole with no binding. Tighten the two socket head cap screws so the index sensor block is secured, and the locking pin moves freely. See FIG. 19.

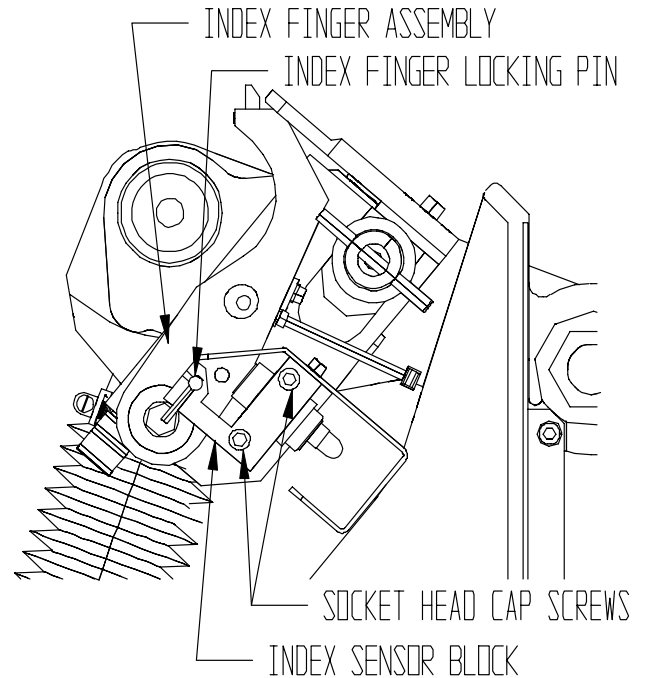

FIG. 19

PROXIMITY SWITCH

For the proximity switch to perform properly and reverse the direction of the carriage at each end of the rails, a distance of $3/16"$ (4 mm) to $1/4"$ (6 mm) needs to be maintained between the carriage proximity flag bracket and the proximity switch. See FIG. 20.

NOTE: Light on proximity activates when metal crosses over the switch.

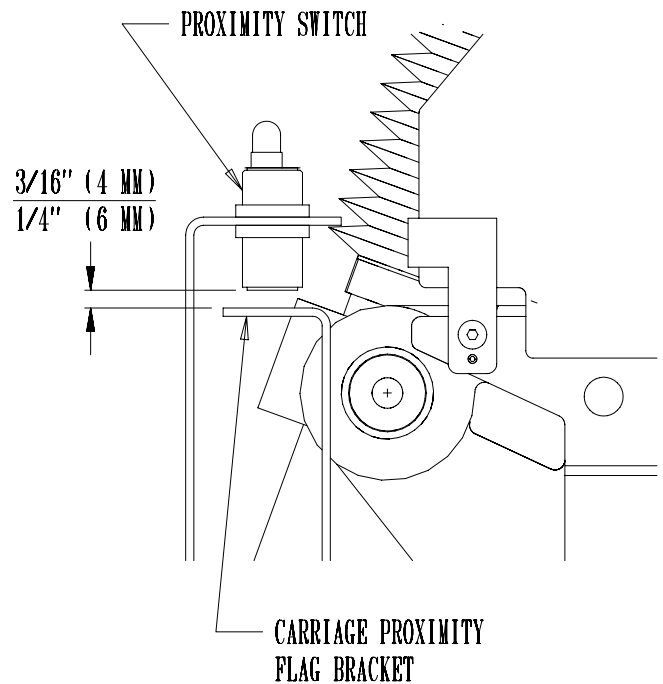

FIG. 20

ADJUSTMENTS (Continued)

ADJUSTABLE RELIEF TENSION

If the relief angle appears to vary during relief grinding, adjust the tension on the nylon plug and set screw. See FIG. 21.

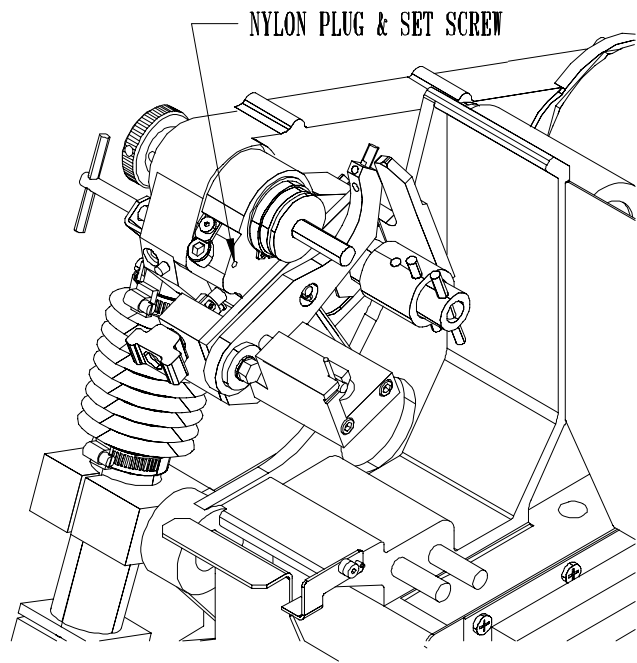

FIG. 21

FREQUENT OVERLOADING AND CIRCUIT TRIPPING

The magnetic starter is factory set at a 12 AMP rating. See FIG. 22.

If your magnetic starter is frequently shutting down, contact your distributor.

The main control power source is for a 15 AMP supply circuit. See machine setup section for explanation.

NOTE: Manual/Auto Selector is factory set at manual mode.

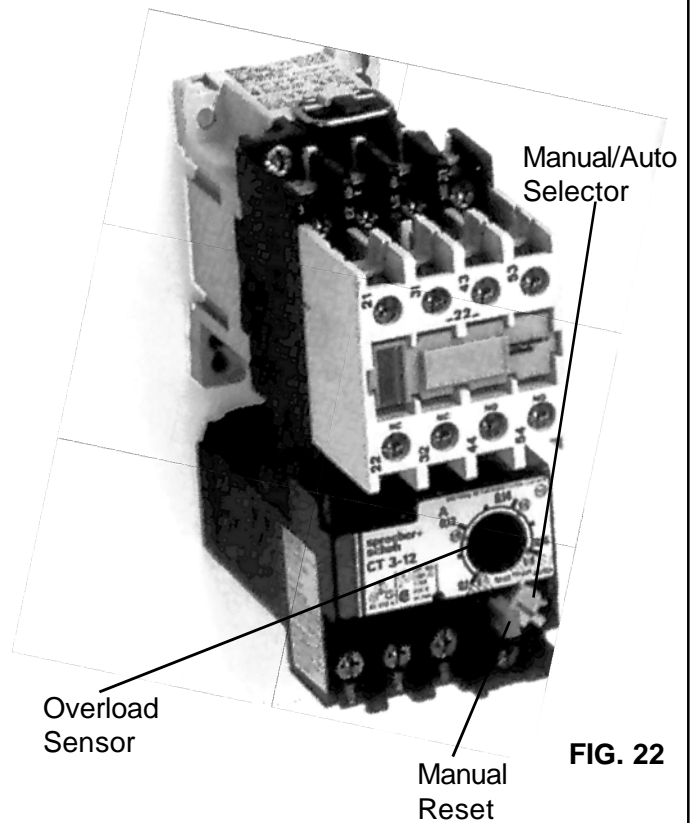

FIG. 22

ADJUSTMENTS (Continued)

SPIN GRINDING ATTACHMENT ADJUSTMENT

If play develops so crank handle wants to rotate in the scissor action on the spin grinding attachment, the play can be eliminated by tightening the set screw identified in FIG. 23.

If there is too much play in the spin drive pivot points, torque down the hex nut tight so conical washer is completely compressed, then back off 1/2 turn. See FIG. 23.

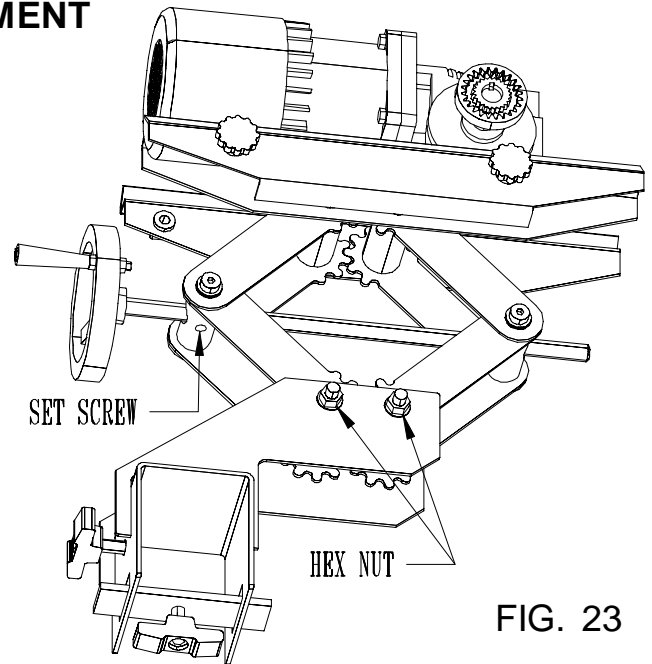

FIG. 23

TRAVERSE MOTOR COUPLING

Traverse motor shaft must be concentric to traverse drive shaft within .010. The traverse shaft and motor shaft are to have at least 1/8" (3 mm) to 1/2" (13 mm) clearance so they do not contact each other. The coupling is to be locked down tightly with the spiral grooves equally spaced for the full length. See FIG. 24.

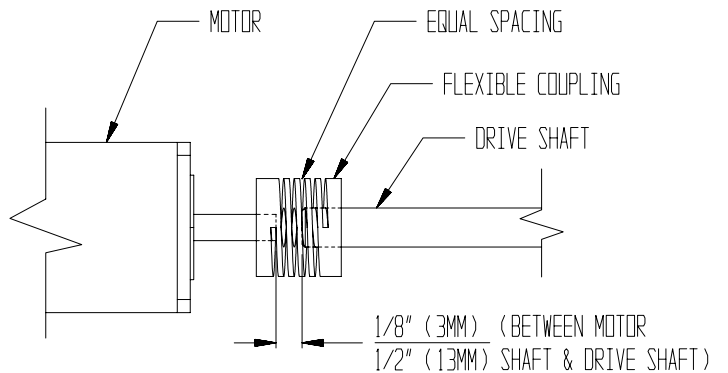

FIG. 24

REDUCER MOTOR ADAPTER TO ACTUATOR DRIVE SCREW CLAMPING COLLAR POSITIONING

The lower clamp collar, next to the reducer motor adapter, is to be positioned flush to the end of the actuator screw shaft and tighten down with 6 ft. lbs (0.8 kg) of torque. See FIG. 25. The top clamp collar is factory adjusted and does not need any further adjustment. There is to be no slippage between the reducer motor adapter shaft and actuator screw when pushing down on grinding head and stalling the reducer motor.

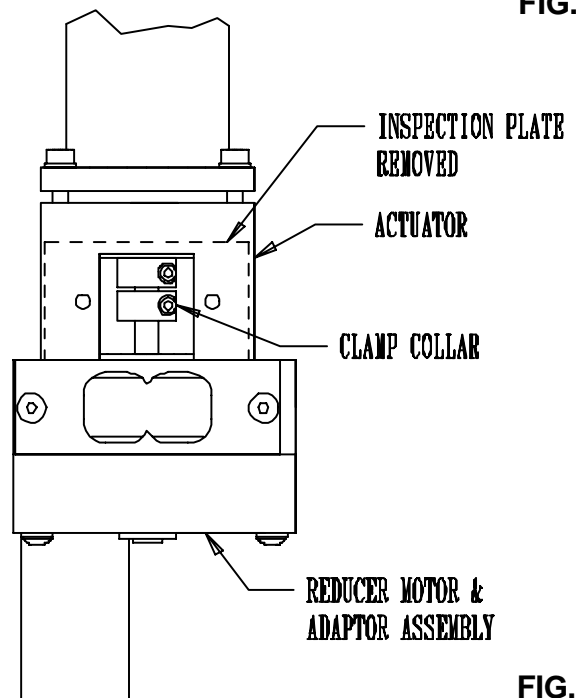

FIG. 25

ADJUSTMENTS (Continued)

ADJUSTING CROSS SLIDE ASSEMBLY

If the cross slide becomes very difficult to turn it may become necessary to adjust the assembly. To relieve the tension on the assembly follow the procedure listed below:

STEP 1--Using a hydraulic jack, raise the traversing carriage base just enough to alleviate the weight stress on the Cross Slide Assembly.

STEP 2--Knock the pins on either side of the Mounting Frame Adjuster and loosen the 4 bolts (B504801) that connect the Carriage Mounting Frame to the frame of the grinder.

STEP 3--Jack the traversing carriage base up to put a preload on the Cross Slide Assembly.

STEP 4--Tighten the 4 bolts on the Carriage Mounting Frame to 75 ft-lbs.

STEP 5--Release the jack pressure and test the vertical and horizontal handwheels for ease of movement through their full range of motion.

STEP 6--If the Cross Slides tend to bind, repeat above steps jacking higher or lower (STEP 1) until the handwheels move freely.

STEP 7--When the Cross Slides move freely through their full range of motion, drill new holes and repin assembly.

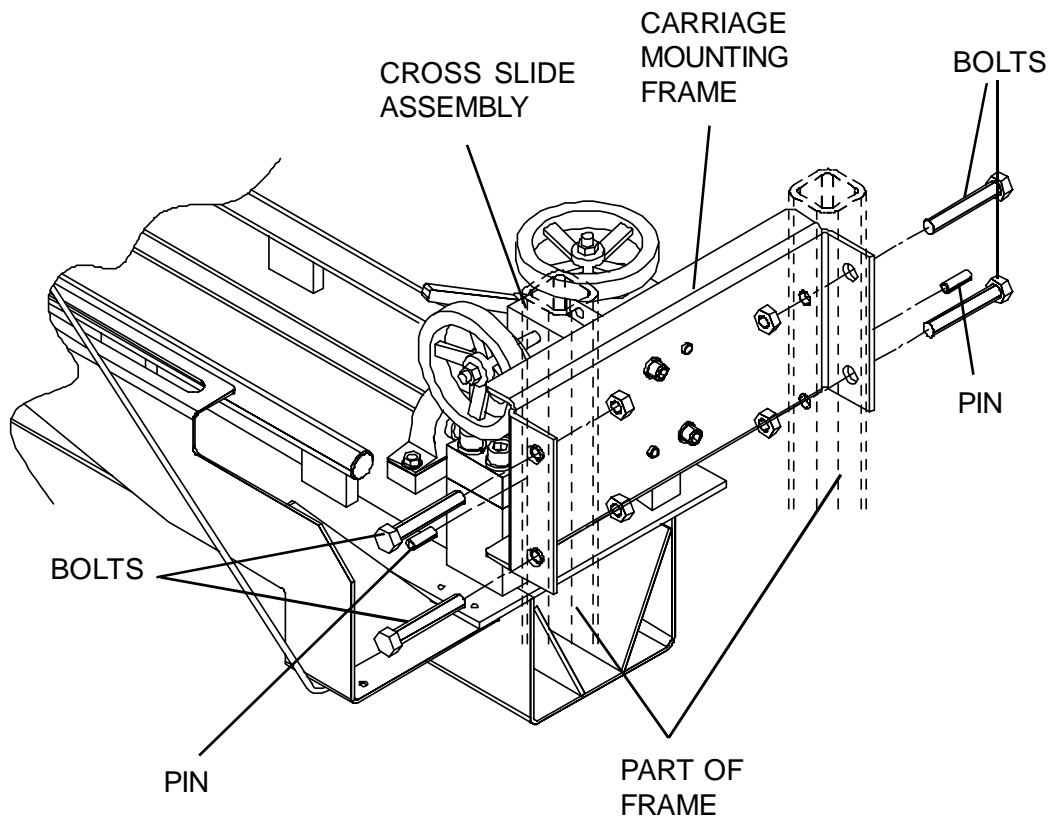

ADJUSTMENTS (Continued)

CROSS SLIDE SHAFT REPLACEMENT

If the cross slide shafts become scarred or gnarled, replace them by the following procedure:

STEP 1--Use a hydraulic jack to raise the weight off the Cross Slide Assembly.

STEP 2--Loosen the two nuts on the support casting that hold the dutchman and tap with plastic hammer to loosen.

STEP 3--Loosen the locking handles and tap the center stud with a plastic hammer.

STEP 4--Loosen locknut and setscrew and remove the handwheel.

STEP 5--Remove the Slide Shaft.

STEP 6--Remove all burrs and resurface the shaft to a clean, smooth, polished surface. (OR REPLACE WITH A NEW SHAFT.)

STEP 7--Coat shaft with Never-Cease and re-install the shaft through the Support, Cross Slide Block and the three Dutchman. The shaft must move freely inside the Cross Slide Block before reassembling.

STEP 8--Retightening the nuts at the end of the Dutchman to lock shaft in place.

STEP 9--Reinstall the Handwheel by snugging the setscrew to the flat located on the screw shaft, then torque nut until tight and back off 1/2 turn. Torque the setscrew to 70 in-lbs.

STEP 10--Test the Cross Slide, the handwheel should turn freely.

STEP 11--Lower the jack and retest the Cross Slide Assembly through full range of motion. If binding occurs, follow the procedure under Cross Slide Assembly located on page 22.

NOTE: It is also possible to remove the complete Cross Slide Assembly and do the repairs on a bench then reinstall.

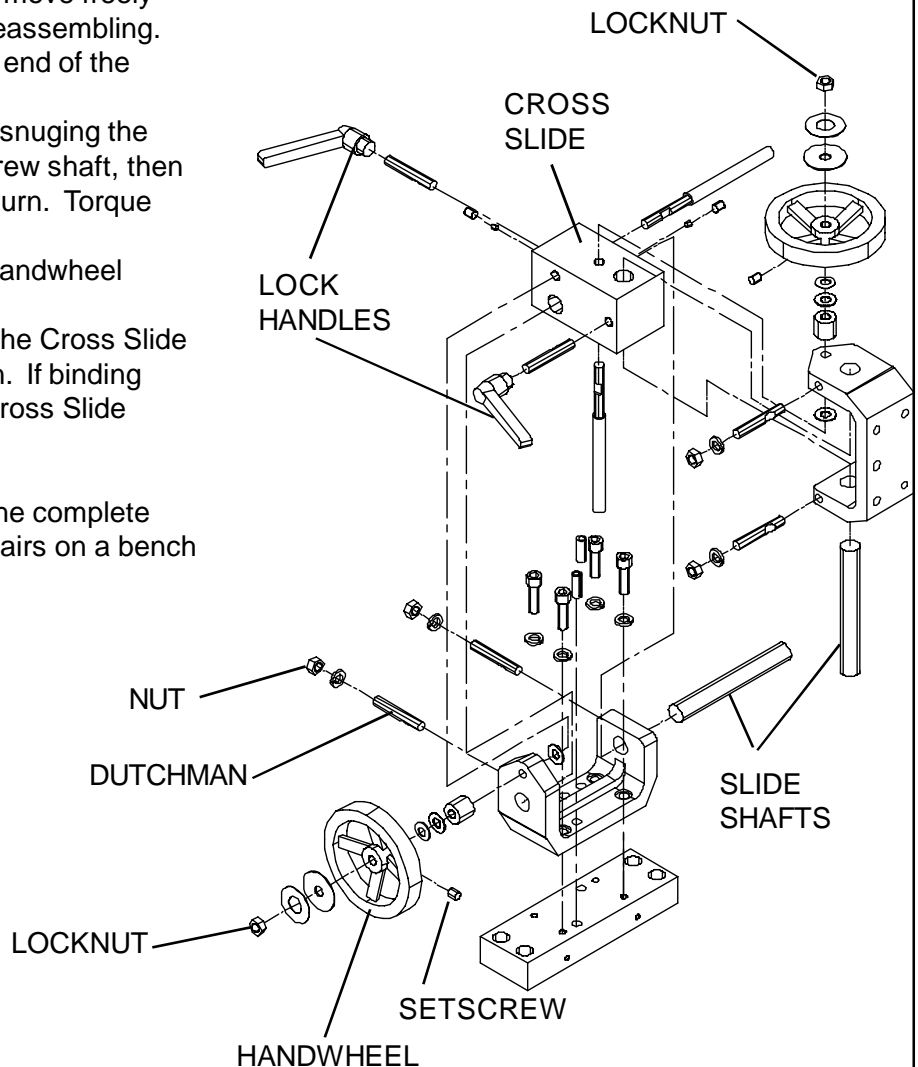
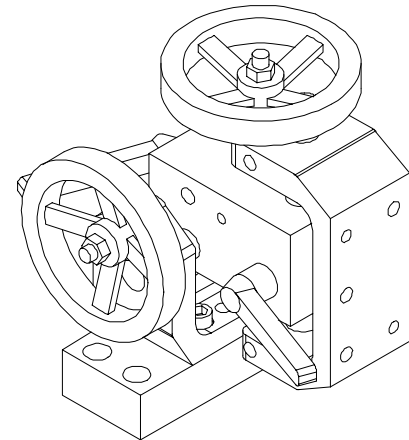

CONTROL BOARD POTENTIOMETER ADJUSTMENTS

POTENTIOMETER ADJUSTMENTS TRAVERSE DRIVE CONTROL (TDC)

Min. Speed--Factory set at full (CCW) 8:30. Do not change this setting.

(Right Traverse) Forward Torque--Factory set at full (CW) 4:30. Do not change this setting.

(Left Traverse) Reverse Torque--Factory set at full (CW) 4:30. Do not change this setting.

IR COMP--Factory set to 9:00. IR COMP is current (I) resistance (R) compensation (COMP).

IR COMP adjusts the output voltage of the drive which balances load to motor RPM. Regulation of a traverse motor may be improved by slight adjustment of the IR COMP trim pot clockwise from its factory-set position. Overcompensation causes the motor to oscillate or to increase speed when fully loaded. If you reach such a point, turn the IR COMP trim pot counterclockwise until the symptoms disappear.

Max. Speed--Set at 3:30 for maximum voltage of 90 Volts DC to the traverse motor. When voltage is above 90 volts DC, the traverse motor will start to pulsate and not run smoothly.

(Right Traverse) Forward Acceleration--Factory set at full (CCW) 8:30. Do not change this setting.

(Left Traverse) Reverse Acceleration--Factory set at full (CCW) 8:30. Do not change this setting.

(DB) Dead Band is the potentiometer setting for the 50 or 60 Hz cycle control. Factory set to 9:00, works for both 50 and 60 Hz. Do not change this setting.

Calibrating the **DWELL TIME** rotary DIP switch adjusts the amount of time the process remains in the stop position after a limit switch is actuated. The **DWELL TIME** range is adjustable from 0 - 4 seconds. A DIP switch setting of 0 sets the **DWELL TIME** to 0 seconds, while a setting of 8 sets the **DWELL TIME** to 4 seconds. Dwell time is preset to #4 setting for a 2 second dwell time when reversing at each end of stroke.

Diagnostic LED's indicate the function that is currently being performed:

- * **POWER** indicates that ac power is being applied to the control.
- * **FORWARD** indicates that the process is running in the forward direction (traversing left).
- * **REVERSE** indicates that the process is running in the reverse direction (traversing right).
- * **PROX 1 FWD LIMIT** lights when the forward limit switch is actuated (left prox).
- * **PROX 2 REV LIMIT** lights when the reverse limit switch is actuated (right prox).
- * **DWELL** lights when the process remains stopped after a proximity switch is actuated.

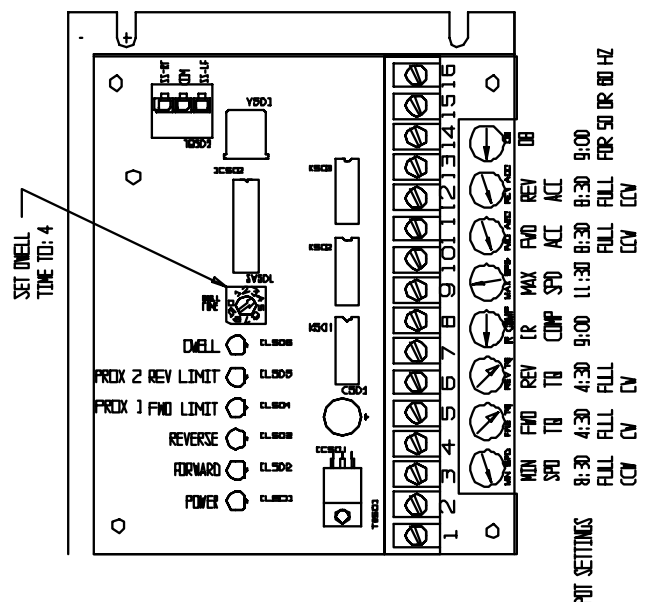
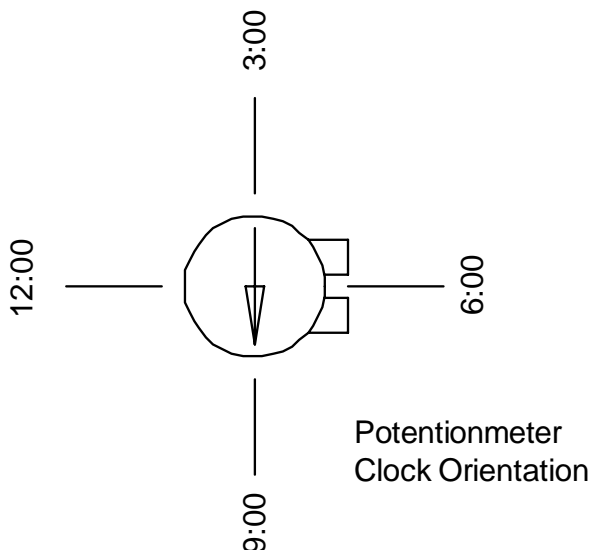

CONTROL BOARD POTENTIOMETER ADJUSTMENTS (Continued)

SPIN DRIVE CONTROL BOARD (SDC)

The Spin Drive Control Board has three potentiometers on the lower board and two potentiometers on the upper board as shown on FIG. 26 and FIG. 27. These potentiometers have been set at the factory to the positions shown on FIG. 26 and FIG. 27.

In the Relief Grinding Mode--

The Relief Speed Pot (RSP) and the Relief Torque Pot (RTP) interact with each other. The (RSP) is located on the upper spin board as a remote speed preset at 2:00 (20 Volts DC). See FIG. 26. The (RTP) is located on the control panel and is for relief torque adjustment.

Relief Speed Pot (RSP) when rotated clockwise will increase maximum spin drive speed. This speed should never be above the 2:30 setting.

Relief Torque Pot (RTP) can vary the reel to finger holding torque for relief grinding. The recommended starting point is 30 in/lbs of torque setting. Never adjust the (RTP) potentiometer dial past the red line marking. Setting the reel to finger torque to high could cause the traverse motor system to not operate smoothly.

In the Spin Grinding Mode--

the Spin Torque Potentiometer (STP) and the Spin Speed Pot (SSP) interact with each other. The (STP) is located on the upper spin board as remote torque preset at 2:00 for torque setting. See FIG. 26. The (SSP) is located on the control panel and is for spin speed adjustment.

Spin Torque Pot (STP) controls maximum torque allowable in the spin grinding cycle only. This should never be adjusted past the 2:30 position. If the reel does not turn check that the reel is free turning by hand spinning.

The Spin speed Pot (SSP) controls reel spin speed, adjust as required. This controls the spin drive speed for spinning the reel.

POTENTIOMETERS ON THE LOWER BOARD OF THE SPIN DRIVE CONTROL (SDC)

See FIG. 27.

Maximum Speed Pot--

The maximum speed is factory preset to 4:30 (fully clockwise) to allow for maximum spin speed.

Minimum Speed Pot--

The minimum speed is factory preset at 8:30 (full counterclockwise) so zero speed is obtainable for spin speed.

IR Compensation Pot--

The IR Compensation is factory set at 9:00.

Regulation of the spin or relief grind spin motor may be improved by a slight adjustment of the IR COMP pot clockwise from its factory-set position. Overcompensation causes the motor to oscillate or to increase speed when fully loaded. If you reach such a point, turn the IR COMP pot counterclockwise until symptoms just disappear.

CONTROL BOARD POTENTIOMETER ADJUSTMENTS (Continued)

GRINDING MOTOR CONTROL BOARD (GMC)

The Grinding Motor Control Board has four potentiometers on the board. These potentiometers have been set at the factory to the positions shown on the drawing. See FIG. 28

Maximum Speed--

The maximum speed potentiometer is preset to 1:00 position for 90 Volts DC to the grinding motor for 4300 RPM. The 4300 RPM is for optimum grinding wheel operating speed. DO NOT go above the 4300 RPM.

Check for 90 to 95 Volts DC on Grinding Motor Control (GMC) at Term A1 to Term A2.

NOTE: OVER VOLTAGE OPERATION CAN BE DAMAGING TO THE MOTOR. DO NOT OPERATE THE MOTOR AT HIGHER THAN 95 VOLTS DC.

Minimum Speed--

the minimum speed is set full counterclockwise so it is nonfunctional for this application.

Current Limit--

The current limit is preset at 3:00 at the factory. The red light above current limit indicates when the grinding motor is above the preset current limit. Going above the current limit causes the motor to pulsate. The current limit can be turned clockwise to increase the motor's maximum torque for grinding overloads. The overload in the control panel will trip if the overload persists for a prolonged period of time. Use a lower grinding head traverse speed if nuisance tripping is experienced.

IR Compensation

Regulation of the grinder motor may be improved by slight adjustment of the IR COMP pot clockwise from its factory-set position. Over compensation causes the motor to oscillate or increase speed when fully loaded. If you reaches such a point, turn the IR COMP pot counterclockwise until the symptoms disappear.

The control is preset to 9:00 position. Never adjust past the 11:00 position when changing the setting to increase higher torque for heavy grinding.

UPPER SPIN BOARD

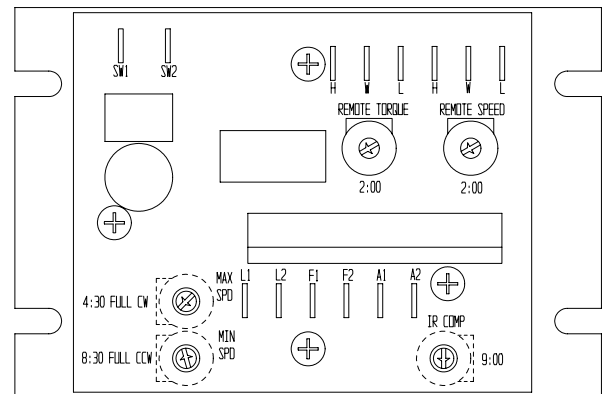

FIG. 26

LOWER SPIN BOARD

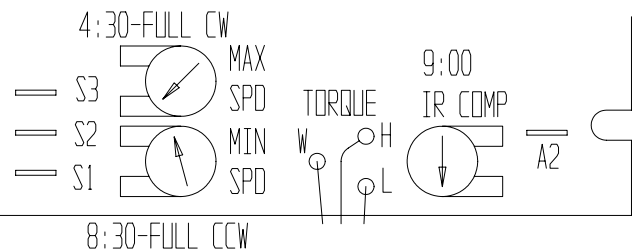

FIG. 27

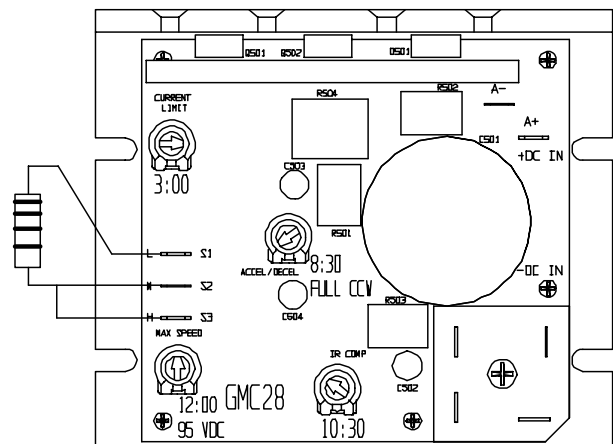

FIG. 28

MACHINE SERVICE (Continued)

Remove grinding wheel and grinding wheel knob. The Grinding Head Spindle Assembly consists of the grinding head spindle and a ball bearing press fit together. The other ball bearing is slip fit on the opposite end during assembly with loctite on the bearing bore. To replace the spindle assembly remove the grinding wheel grip knob, square key and belt cover. See FIG. 30. Loosen the 4 socket head cap screws on the motor to remove the poly-V belt. Loosen the 2 set screws on the spindle pulley and remove the pulley, square key and pulley spacer. Push on the right hand side of the spindle assembly to compress conical washers so there is no pressure on the shaft retaining ring and to expose the retaining ring for removal. Using a retaining ring pliers remove the small retaining ring from the spindle assembly. You can now remove the spindle assembly out the right side by lightly rapping on the left end with a rubber mallet. The second ball bearing can be removed from the belt side of the Grinding Head Housing.

To reassemble place the 4 conical washers (2 Pair nested and then place the 2 pairs back to back) against the ball bearing on the new spindle assembly. See FIG. 31. Slide this assembly into the Grinding Head Housing and slip fit the new second ball bearing onto the spindle assembly and into grinding head housing (apply loctite #242 to the bore of the bearing before assembling). Using a C-clamp compress the conical washers so you can replace the retaining ring. The retaining ring is fragile and easily damaged when removing. Always use a new retaining ring when reassembling and grinding head spindle. Only open the retaining ring enough to install. Opening the ring excessively will damage the retaining ring, making it unusable.

Replace the pulley spacer and mount the square key positioned tight against the pulley spacer. Remount the pulley pushing against the pulley spacer and bottom out against the snap ring with no end play. Next tighten the two pulley set screws. Then remount the poly-V belt. (See Grinding Head Belt Tension Adjustment in the adjusting section). Replace belt cover and square key and mount the grinding wheel grip knob and tighten the two set screws.

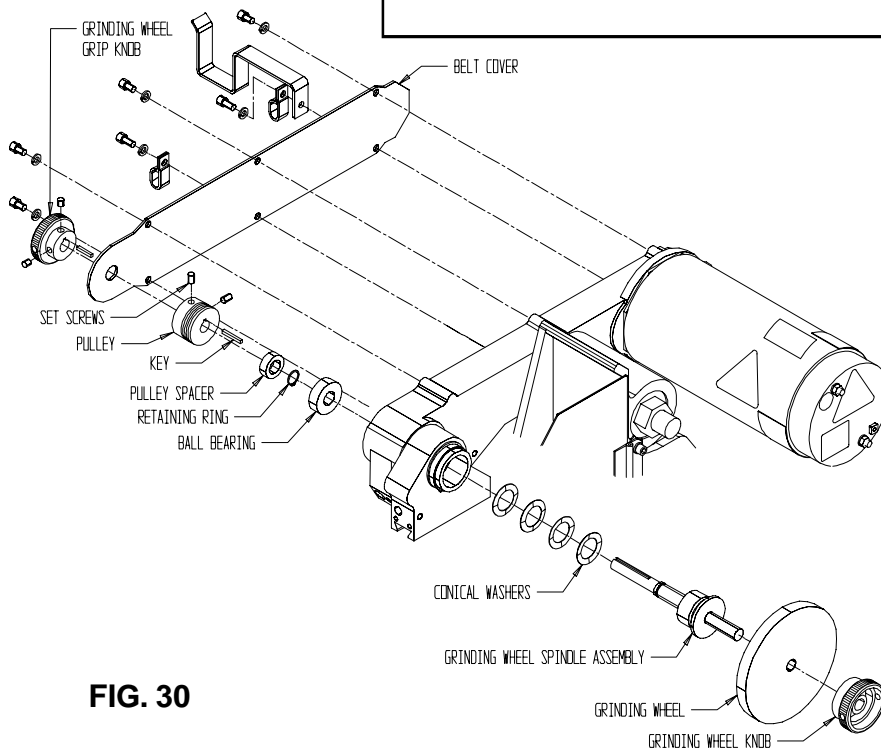
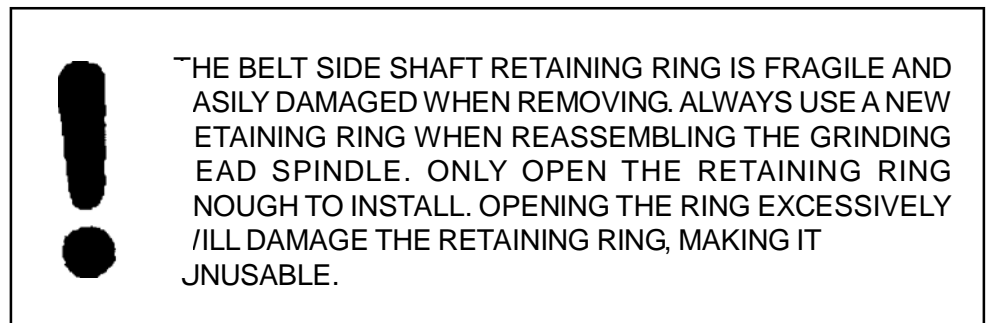

FIG. 30



FIG. 31

ELECTRICAL TROUBLESHOOTING

SKILL AND TRAINING REQUIRED FOR ELECTRICAL SERVICING

This Electrical Troubleshooting section is designed for technicians who have the necessary electrical knowledge and skills to reliably test and repair the ACCU-Pro electrical system. For those without that background, service can be arranged through your local distributor.

This manual presumes that you are already familiar with the normal operation of the Grinder. If not, you should read the Operators Manual, or do the servicing in conjunction with someone who is familiar with its operation.

Persons without the necessary knowledge and skills should not remove the control box cover or attempt any internal troubleshooting, adjustments, or parts replacement.

If you have any question not answered in this manual, please call your distributor. They will contact the manufacturer if necessary.

WIRE LABELS

All wires on the ACCU-Pro have a wire label at each end for troubleshooting. The wire label has a code which tells you wiring information. The wire label has a seven position code. The first two digits are the wire number: 01-99. The next three numbers or letters are the code for the component to which the wire attaches. Example: GMC for Grind Motor Control. The last two numbers or letters are the number of the terminal on the component to which the wire attaches.

ELECTRICAL TROUBLESHOOTING INDEX

AC Main Power Controls	Page 29-31
Spin Drive Controls in Spin Mode	Page 32-33
Spin Drive Controls in Relief Mode	Page 34-36
Grinding Motor Controls	Page 37-38
Traverse Drive Controls-w/prox	Page 39-40
Traverse--stopping and reversing	Page 41-43
Infeed Controls	Page 44-45

ELECTRICAL TROUBLESHOOTING (Continued)

PROBLEM--AC Main Power Controls: no electrical power to control panel.

Verify all wires shown on the wiring diagram on pages 72-75 are correct and pull on wire terminals with approximately 3 lbs force to verify there are no loose terminal connections and/or no loose crimps between wire and terminal. If problem persists, test as listed below.

Possible Cause	Checkout Procedure	
You must push the System Start Switch (SSS) to get power to control Panel	A. Listen for the Magnetic Starter (MAG) contacts to pull in with a clunk	Machine works Yes--end troubleshooting No--go to Step B. next
Main Power Cord is not plugged in	B. Plug in main power cord	Machine works Yes--end troubleshooting No--go to step C. next.
Guard doors must be closed and latched for contactor to pull in.	C. Close and latch guard doors.	Machine works Yes--end troubleshooting No--go to step D. next.
Main 15 amp outlet circuit breaker has tripped	D. Check circuit breaker in your building and reset if necessary. (Check wall outlet with a light to make sure it works)	Machine works Yes--end troubleshooting No--but light works in outlet--go to Step E. next. No--but light does not work in outlet. You must solve your power delivery problem independent of machine.
No 115 volts AC power to (MAG)	E. Check for incoming power (MAG) for 115 Volts.	(MAG) Terminals L1 to L2 for 115 Volts AC Yes-- Go to Step F next. No--Replace the main power cord #32
No 115 Volts AC power out of (MAG)	F. Check for 115 V	(MAG) Term #T1 to T3 for 115 Volts AC Yes--check continuity of wires between T1 and T3 to switches
(MAG) not working	G. Push reset button on front of (MAG) Ref: Factory set for 12 amp	This may have tripped from either a motor overload condition or during machine shipment. Push (SSS). If machine works-- Yes--end troubleshooting No--go to Step H. next
	H. Contactor coil chatters when (MAG) is powered up. Tighten terminals T1 , T2, & T3 that connect the overload and contactor together	Bad contacts in contactor cause it not to hold in when turned on. If machine works: Yes-- end troubleshooting No--go to Step I. next

ELECTRICAL TROUBLESHOOTING (Continued)

<u>Possible Causes</u>	<u>Checkout Procedure</u>	
115V power not delivered to (MAG) coil.	I. Check at Magnetic Starter coil for 115 Volts AC with main electrical power on and pushing (SSS) and Grinding Motor Switch (GMS) in the off position.	(MAG) Term #A1 to A2 for 115 volts AC Yes--replace magnetic starter No--go to Step J. next
No power to the control circuit	J. Check voltage to Fuse F1	Measure 115 volts AC from fuse wire #02 at the fuse end to (MAG) L2. Yes-- Go to Step K. next No--Check continuity of wire #02, if bad replace
Blown Fuse F1	K. Check voltage after Fuse F1	Measure 115 Volts AC from fuse wire #03 at the fuse end to (MAG) L2. Yes--To Step L. next No--Replace fuse
Bad Emergency Stop Switch (ESS)	L. Check voltage after the (ESS)	Measure 115 Volts AC from (ESS) term 2 to (MAG) L2 Yes--Go to Step M. next No--Check wire #03 for continuity, then verify switch continuity. If bad replace EES
Door saftey switch not operating	M. Check output of safety switch with guards closed	Check light on end of the safety switch. Light should be off when guard is closed, on when opened. Yes--Go to Step N. next No--Go to Step U. next.
	N. Check voltage	Measure 24 Volts DC at the saftey switch, between the Orange and Gray wire. Yes--Go to Step O. next No--Replace Saftey Switch
Relay (REL) not operating	O. Check voltage at relay (REL2)	Measure 24 Volts DC at (REL2) term 0 and 1. Yes--Go to Step P. next. No--Verify continuity of wires between the saftey switch and (REL2)
Bad Relay contact	P. Check relay contact	With saftey switch on and (REL2) on, measure 115 Volts AC at relay term 8 to 6 Yes--Verify wiring, Replace relay No--Check continuity of wires on relay.

ELECTRICAL TROUBLESHOOTING (Continued)

<u>Possible Cause</u>	<u>Checkout Procedure</u>	
System Start Switch (SSS) not functioning.	Q. Check push button contact input.	Measure 115 volts AC at switch term 3 to (MAG) L2 Yes--Go to Step R. next No--Check continuity of wire #89 from SSS to GMS, 89 from GMS to REL, term 6.
	R. Check push button contact output.	Measure 115 Volts AC at switch term 4 to (MAG) L2 with button pressed Yes-- Go to Step S. next No--Replace switch
(MAG) not operating	S. Check contractor action.	Measure 115 Volts AC at A1 and A2 on contractor with (SSS) on. Yes--If MAG is not clicking on, replace contractor No--Go to Step T. next.
	T. Check related wiring.	Check Related wiring to (MAG) Check continuity of wire 23 from SSS terminal 4 to (MAG) terminal 14. Check continuity wire 17 from (MAG) terminal 14 to (MAG) terminal A1. Check voltage at (MAG) With SSS on, measure 115 Volts AC at (MAG) A1 to (MAG) L2. Yes--Check continuity of wire 15 from (MAG) term 96 to (MAG) term A2
Bad power to Saftey Circuit	U. Confirm 24 Volts DC to saftey circuit.	Measure 24 Volts DC at Bridge diode (BD2) terminal 107BD2+ to term 107BD2 - Yes--Verify continuity of wires between BD2 and door saftey switch / replace saftey switch N o . . . G o o t o S t e p V. next
Bad Bridge Diode	V. Measure voltage	Measure 24 Volts AC at input of (BD2). Terminal (~) to Terminal (~) Yes--Replace Bridge Diode (BD2) No-- Go to Step W. next
Bad Fuse or Transformer	W. Measure voltage	Measure 115VAC at primary of (TFR) The two black wires are the primary side. Yes--Replace Transformer (TFR) No-- Check Fuse FU3 and replace if needed. Verify wiring from FU3 to TFR.
PROBLEM--(MAG) turns on only with System Start Switch held in.		
<u>Possible Cause</u>	<u>Checkout Procedure</u>	
(MAG) holding contact has failed	A. Check wiring to and from MAG holding contact in. Verify the magnetic starter holding contact is working.	Measure 115 Volts AC at MAG term 13 to 14 with SSS not pushed. Yes--Replace contactor No--Verify wiring to 13 and 14. If bad replace.

ELECTRICAL TROUBLESHOOTING (Continued)

PROBLEM--SPIN DRIVE NOT WORKING IN SPIN MODE.

Assuming (SSS) System Start Switch is on with 115 volts AC to control panel and all other functions are working.

Verify all wires shown on the wiring diagram on pages 72-75 are correct and pull on wire terminals with approximately 3 lbs force to verify there are no loose terminal connections and/or not loose crimps between wire and terminal. If loose terminals are found, retighten and retest system. If problem persists, test as listed below.

Possible Cause

Checkout Procedure

Spin Speed Pot (SSP) set to zero

A. Set (SSP) to 200 on the control panel.

Spin Motor works
Yes--end troubleshooting
No--go to Step **B** next

Spin Rotation Switch (SRS) are not on

B. Turn (SRS) switch to direction of reel rotation required. NOTE: center position is off

Spin Motor works
Yes--end troubleshooting
No--go to Step **C**. next

Fuse 2 (4 AMP) is blown

C. Check fuse and replace if bad. Check that reel is free spinning.

Spin Motor works
Yes--end troubleshooting
No--go to Step **D**. next

Spin Rotation Switch (SRS) is not working

D. Check for (SRS) input of 115 Volts AC

(SRS) Term 5 to term 8 for 115 Volts AC
Yes--go to Step **E**. next
No--after verification of 115 VAC power at (MAG) term's T1 and T3, replace wire 91 & 92

E. Check for (SRS) output of 115 Volts AC NOTE: Check spin rotation switch in both positions.

(SRS) Term 1 to term 4 for 115 Volts AC
Yes--go to Step **F**. next
No--replace (SRS) switch

Spin Drive Control (SDS) is not working

F. Check (SDS) L1 to L2 for 115 Volts AC

(SDC) Term L1 to term L2 for 115 volts AC
Yes--go to Step **G**. next
No--replace wires 82, 83 and 24

G. Check (SDC) A1 & A2 for approx. 90 Volts DC (Have Spin Speed Pot set to 400 RPM)

(SDC) Term A1 to A2 for approx 90 volts DC
Yes--go to Step **H**. next
No--go to Step **L**. next

H. Check for approx 90 Volts DC input to (SRS)

(SRS) Term 6 to 7 for approx 90 Volts DC
Yes--go to Step **J**. next
No--replace wires 13 & 14

J. Check for approx 90 Volts DC out put to (SRS).

(SRS) Term 2 to 3 for approx 90 Volts DC
Yes--go to Step **K**. next
No--replace (SRS) switch

Spin Drive motor is bad

K. Check spin motor continuity

Remove wires at (SRS) Term 2 & 3 check 0 ohms across the black and white wires
Yes--end troubleshooting
No--got to Step **P**. next



Disconnect Power from Machine!

ELECTRICAL TROUBLESHOOTING (Continued)

Possible Cause

Checkout Procedure

Spin Speed Pot (SSP) is not working

L. (SSP) (10K) on control panel

Input/output Controller (IOC) Pin #36 to 41
 Pot Full CCW --0 volts DC
 Pot Full CW--4.21 Volts DC
 (IOC) Pin #36 to 43
 Pot Full CCW --4.12 Volts DC
 Pot Full CW-- DC 0 Volts DC

Spin Torque Pot (STP) is not set correctly

M. Check (STP) remote torque on the top (SDC) board

(STP) OK (SDC) remote torque should be set at 2:00 o'clock position. See Fig. 26. Adjust if incorrect and check Spin Drive Function.
 Yes--end of troubleshooting
 No--Replace (SDC)

(SSP) is not working

N. (SSP) (10K) Remove 3 Remote Speed wires.
 Red wire to term W
 White wire to term L
 Black wire to term H

Check for 10,000 ohms
 Red wire to white wire
 Full CCW--0 ohms
 Full CW-10,000 ohms
 Red wire to black wire
 Full CCW--10,000 ohms
 Full CW--0 ohms
 Yes--replace (SDC)
 No--replace (SSP)

Worn Motor Brushes

P. Inspect Motor Brushes

Remove the brushes one at a time and maintain orientation for reinsertion. See if brush is worn short 3/8" (10 mm) minimum length.
 Yes--replace motor brushes
 No--replace Spin Drive Motor



DISCONNECT POWER FROM MACHINE !

ELECTRICAL TROUBLESHOOTING (Continued)

PROBLEM--Spin Drive not working in relief mode.

Assuming (SSS) System Start Switch is on with 115 volts AC to control panel and all other functions are working.

Verify all wires shown on the wiring diagram on pages 72-75 are correct and pull on wire terminals with approximately 3 lbs force to verify there are no loose terminal connections and/or no loose crimps between wire and terminal. If loose terminals are found, retighten and retest system. If problem persists, test as listed below.

Possible Cause

Checkout Procedure

Relief Torque Pot (RTP) set to zero

A. Set (RTP) to 20 on the control panel

Spin Motor works
Yes--end troubleshooting
No--go to Step B. next

Spin Rotation Switch (SRS) are not on.

B. Turn (SRS) switch to direction of reel rotation required.
NOTE: center position is off.

Spin Motor works
Yes--end troubleshooting
No--go to Step C. next

Fuse 2 (4 AMP) is blown

C. Check fuse and replace if bad. Check that reel is free spinning

Spin Motor works
Yes--end troubleshooting
No--go to step D. next

(SRS) is not working

D. Check for (SRS) input of 115 Volts AC

(SRS) Term 5 to term 8 for 115 Volts AC
Yes--go to Step E. next
No--After verification of 115 Volts AC power at (MAG) term. T1 & T3, replace wire #77 & 79.

E. Check for (SRS) output of 115 Volts AC NOTE: Check spin rotation switch in both positions

(SRS) Term 1 to term 4 for 115 Volts AC
Yes--go to Step F. next
No--replace (SRS) switch

Spin Drive control (SDC) is not working.

F. Check (SDC) L1 to L2 for 115 Volts AC

(SDC) Term L1 to term L2 for 115 Volts AC
Yes--go to Step G. next
No--replace wires #82, 83 & 24

G. Check (SDC) A1 & A2 for approx 20 Volts DC. Have Relief torque Pot (RTP) set to red line.

(SDC) Term A1 to A2 for approx 20 Volts DC
Yes--go to Step H. next
No--go to Step L. next

H. Check (SRS) for approx 20 volts DC output

(SRS) Term 6 to 7 for approx 20 Volts DC
Yes--go to Step J. next
No--replace wires 13 & 14

J. Check (SRS) for approx 20 Volts output

(SRS) Term 2 to 3 for approx 20 Volts DC
Yes--go to Step K. next
No--replace (SRS) switch

Spin Drive Motor is bad

K. Check spin motor continuity

Remove wire at (SRS) Term #2 & 3 for 0 ohms across the black and white wires
Yes--end troubleshooting motor should work (if it does not, replace motor)
No--go to Step P. next



DISCONNECT POWER FROM THE MACHINE

ELECTRICAL TROUBLESHOOTING (Continued)

Possible Cause

Checkout Procedure

(RTP) Relief Torque Pot is not working

L. Check (RTP) (50K) on control panel (check voltage with pots at fully clockwise and counterclockwise positions)

(SDC) Term Remote Torque W to H Pot CCW-- volts DC
Pot CW-- .21 Volts DC
(SDC) Term Remote Torque W to L Pot CCW-- .21 Volts DC
Pot CW-- DC 0 Volts DC
Yes--go to Step **M.** next
No--go to Step **N.** next

Relief Speed Pot (RSP) is not set correctly.

M. Check (RSP) remote speed (10k) on (SDC) top board (this is preset to 9:00)

(RSP) to the top (SDC) board should be set at 2:00. See Fig. 26. Adjust if incorrect and check Relief Torque function.

Yes--end of troubleshooting
No--replace (SDC)

(RTP) is not working

N. (RTP) (50K) Remove 3 Remote Torque Wires
red wire to term W
white wire to term L.
black wire to term H.

Check for 50,000 ohms
Red wire to white wire
Full CCW--0 ohms
Full CW--50,000 ohms
Red wire to black wire
Full CCW--50,000 ohms
Full CW--0 ohms
Yes--Replace (SDC)
No--replace (RTP)

Worn Motor Brushes

P. Inspect Motor Brushes



DISCONNECT POWER FROM MACHINE !

Remove the brushes one at a time and maintain orientation for reinsertion. See if brush is worn short 3/8" (10 mm) minimum length
Yes--replace motor brushes
No--replace Spin Drive Motor

PROBLEM : Spin drive speed goes at one speed only.

Possible Cause

Remedy

Wiring hookup to potentiometer is improper. (If components have been replaced

A. Check potentiometer wiring for proper hookup. See that speed pot is wired per electrical diagram

If wiring is wrong, correct and test.
Yes--end of troubleshooting
No--Go to Step B. next

Defective spin speed control (SSP) potentiometer.

B. (SSP) 10K Remove 3 remote speed wires.
red wire to term W
white wire to term L
black wire to term H

Check for 10,000 ohms
Red wire to white wire
Full CCW--0 ohms
Full CW--10,000 ohms
Red wire to black wire
Full CCW--10,000 ohms
Full CW--0 ohms
Yes-- Go to Step C. next
No--Replace (SSP)

Main circuit board dial pot settings not correct. (If board has been replaced

C. Check all pot settings on both boards as of the (SDC) shown on Page 22. (See Adjustment Section Spin Drive Control [SDC] Board Setting).

Yes-- end of troubleshooting
No--replace (SDC)

PROBLEM: Spin drive motor speed varies

IR Comp trim pot not adjusted properly.

A. See adjustment section for trim pot setting on Page 24.

Original adjustment was not set properly

Torque to rotate the reel too high.

B. Readjust bearing preload for the reel. Maximum torque load 25 in./lb to rotate reel.

Too much load on drive motor will cause motor to hunt and vary speed.

Check all terminal connections for tightness.

C. When .250 female spade terminals are not tight, remove and crimp slightly together. When re-installing, push on pressure should have increased for good contact.

When connections are not tight the control board varies voltage to the DC motor which then varies speed.

ELECTRICAL TROUBLESHOOTING (Continued)

PROBLEM-- Grinding motor not working.

Assuming (SSS) System Start Switch is on with 115 volts AC to control panel and all other manual (jog) mode functions are working.

Verify all wires shown on the wiring diagram on pages 72-75 are correct and pull on wire terminals with approximately 3lbs force to verify there are no loose terminal connections and/or no loose crimps between wire and terminal. If loose terminals are found, retighten and retest system. If problem persists, test as listed below.

Possible Cause	Checkout Procedure	
Grinding Motor Switch (GMS) is not on	A. Turn switch on	Grinding Motor works Yes--end troubleshooting No--go to Step B. next
Guard doors are not closed and latched	B. Close and latch guard doors.	Grinding Motor works Yes--end troubleshooting No--go to Step C. next
GMS not working	C. Check for power to GMS	GMS term 5 (MAG) to T3 for 115 Volts AC Yes--go to Step D. next No--With power off, check continuity of wire 78 and replace if bad.
	D. Check for power from GMS	GMS Term 4 to (MAG) T3 for 115 Volts AC Yes--Go to Step E. next No--replace GMS
Relay (REL1) not working	E. Check for power to relay coil	(REL1) Term 0 to 1 for 24 Volts DC. Yes--go to Step F. next No--Doors not closed or door switch bad. Follow separate troubleshooting on power.
Relay contacts not working	F. Check for power to relay contacts	(REL1) Term 2 on (MAG) T3 for 115 Volts AC Yes--Go to Step G. next No--Replace wire #81
	G. Check for power from relay contacts	(REL) Term 4. to T3 for 115 Volts AC Yes--Go to Step J. next No--Replace (REL)
	I. Check line side of filter for input of 115 volts AC	(FTR) wire #98BL to #98 WH for 115 Volts AC Yes--go to Step J. next No--replace wire #98
Filter (FTR) is not working (Filter is located in the second control box at the inside back of the grinder	J. Check load side of filter for output of 115 Volts AC	(FTR) Wire 361 to #62 for 115 Volts AC Yes--go to Step K. next No--replace (FTR)

ELECTRICAL TROUBLESHOOTING (Continued)

Possible Cause

Checkout Procedure

Grinding Motor Control (GMC) is not working (GMC) is located in the second control box at the inside back of the grinder.

K. Check (GMC) for input voltage of 115 Volts AC

(GMC) Term L1 to L2 for 115 Volts AC
Yes--go to Step **L.** next
No--replace wires #61 and #62

L. Check (GMC) resistor assy wire connections.

(GMC) Term #S1, 52 and S3 for loose wires
Yes--repair or replace resistor assembly
No--go to Step **M.** next.

M. Check (GMC) output voltage of 90 Volts DC to motor.

(GMC) Term #A1 for 90 +/- 5 volts DC
Yes--go to Step **N.** next**
No--if 0 V replace (GMC)

Grinding Head DC Motor cord is bad (remove back cover to motor)

N. Check grinding motor cord #01.

At DC motor check Term #A1 to #A2 for 90 Volts DC
Yes--go to Step **O.** next
No--replace grinding motor cord #97

Grinding Motor is bad

O. Check grinding motor continuity



DISCONNECT POWER FROM MACHINE!

Remove wires at terminal A1 and A2 at motor. Check for 0 ohms across terminals A1 and A2
Yes--end troubleshooting
No--go to Step **P.** next

Worn Motor Brushes

P. Inspect Motor Brushes.



DISCONNECT POWER FROM MACHINE!

Remove the brushes one at a time and maintain orientation for reinsertion. See if brush is worn short 9/16" (14mm) minimum length.
Yes--replace motor brushes.
No--replace Grinding Motor.

****NOTE:** If voltage checks less than 90 VDC, but not 0 VDC, then adjust MAX SPEED POT on the (GMC) until you read 90 VDC. If you cannot achieve 90 VDC, replace the (GMC).



ELECTRICAL TROUBLESHOOTING (Continued)

PROBLEM--Traverse Drive not working.

Assuming (SSS) System Switch is on with 115 Volts AC to control panel and all other functions are working.

Possible Cause	Checkout Procedure	
Traverse Motor Switch (TMS) is not on	A. Turn on (TMS)	Traverse works Yes--end troubleshooting No--got to Step B. next
Traverse Speed Pot (TSP) set to zero	B. Set (TSP) to 35 on the control panel	Traverse works Yes--end troubleshooting No--go to Step C. next
Fuse on Traverse Drive Control (TDC) has failed	C. Check fuse and replace if failed. See Page ? ?. Too heavy a grind causes grinding head traverse motor to overload and blow the fuse,	Traverse works Yes--end troubleshooting No--go to Step D. next
Traverse Drive Control (TDC) is bad	D. Check for 115 Volts AC incoming to (TDC)	On (TDC) Terminal L1 to L2 for 115 Volts AC Yes--Go to Step F. next No--Go to Step E. next
Bad wires to (TDC)	E. Check for 115 Volts AC at (TMS). (Make certain (TMS) is on)	Check for 115 Volts AC at Term 1 & 4 of the (TMS) Note: Switch must be on. Yes--With power off, check continuity of wires 28 & 29, if bad replace wires. No--Check 115 Volt AC power delivered to (TMS) Term 2 & 5 per separate AC power troubleshooting section.

ELECTRICAL TROUBLESHOOTING (Continued)

Possible Cause	Checkout Procedure	
No DC Voltage from (TDC) Traverse Drive Control	F. Check for 90 Volts DC across (TDC) terminals #A1 to #A2 this voltage drives the DC traverse motor. NOTE: Traverse must be on and have (TSP) turned full CW to maximum voltage of 90 VDC	Check (TDC) terminals #A1 to #A2 for 90 Volts DC Yes--go to Step G. next No--go to Step H. next
Traverse Motor is bad	G. Check grinding motor continuity  DISCONNECT POWER FROM MACHINE	Remove motor wires from Jumper #J1 terminals #A1 & #A2 0 ohms across the black and white wires Yes--end troubleshooting No--go to Step K. next
(TSP) is not working	H. Check (TSP) (10K) on control panel	(TDC) Pin #8 to #7 Pot Full CCW Pot Full CW 0VDC 9.75 VDC Pin #8 to 9 Pot Full CCW Pot Full CW 9.75 VDC 0 VDC Yes--replace the (TDC) No--go to Step J. next
(TSP) (10K) is bad	J. Check (TSP) for 10,000 ohms. Remove three wires from (TDC) red from term #8 white from term #7 black from term #9	Check for 10,000 ohms red to white wires Full CCW--0 ohms Full CW--10,000 ohms Red to black wires Full CCW--10,000 ohms Full CW--0 ohms Yes--replace the (TDC) No--replace (TSP)
Worn motor brushes	K. Inspect Motor Brushes  DISCONNECT POWER FROM MACHINE	Remove the brushes one at a time and maintain orientation for reinsertion. See if brush is worn short, 3/8" (10 mm) minimum length. Yes--replace motor brushes No--replace Traverse Motor

ELECTRICAL TROUBLESHOOTING (Continued)

PROBLEM--Traverse does not stop to reverse directions when flag goes under the proximity switch on the left side or right side of machine.

Possible Cause Checkout Procedure

<p>Gap between flag and prox is incorrect.</p>	<p>A. Gap between flag and prox should be 3/16 to 1/4" (4-6 mm). Prox LED does not light when flag is under prox.</p>	<p>If incorrect, adjust per adjustment section of manual. Yes--end troubleshooting No--go to Step B. next</p>	
<p>Proximity Switch is bad.</p>	<p>B. Proximity switch is not working properly or wire connections are loose.</p>	<p>First check to see if proximity light comes on. When the light is on, it means that there is electricity coming to proximity switch. Actuate prox switches with steel tool to take measurements.</p>	<p>The light coming on shows the proximity is getting electrical contact.</p>
		<p>Left proximity (PROX 1) check Traverse drive Control (TDC) between terminals #13 (black wire) and #15 (brown wire).</p>	<p>Proximity light on- 0 Volts DC Proximity light off- 12 Volts DC</p>
		<p>Right proximity (PROX) check #13 (black wire) and #15 (brown wire).</p>	<p>Proximity light on- 0 Volts DC Proximity light off- 12 Volts DC</p>
			<p>Replace proximity switch if the voltages do not read as above.</p>

ELECTRICAL TROUBLESHOOTING (Continued)

PROBLEM--Traverse speed control goes at one speed only.

Possible Cause

Checkout Procedure

Defective speed control potentiometer

A. Check potentiometer on control panel.

Traverse Drive Control Pin #8 to 7
 Pot full CCW Pot Full CW
 0 VDC 9.75 VDC
 Pin #8 to 9
 Pot full CCW Pot Full CW
 9.75 VDC 0 VDC
 Yes--Pot is OK
 No--Go to Step **B.** next

B. Check potentiometer for 10,000 ohms.
 Remove three wires from Traverse Drive Control
 red from term #8
 white from term #7
 black from term #9

Check for 10,000 ohms
 Red to White wires
 Full CCW - 0 ohms
 Full CW - 10,000 ohms
 Red to Black wires
 Full CCW - 10,000 ohms
 Full CW - 0 ohms
 Yes--Go to Step **C.** next
 No--replace potentiometer.
 Wiper inside of potentiometer controls speed. Wiper may be bad and not making contact.

Wiring hookup to potentiometer is improper. (If components have been replaced.)

C. Check potentiometer wiring for proper hookup. See that speed pot is wired per electrical diagram

Wrong wire hookup effects traverse control. Reversing red and orange wires to potentiometer to the D C motor will run at zero speed but maximum will be too slow. Reversing red and white wires does not affect speed control.
 Check for Proper function.
 Yes--end troubleshooting
 No--Go to Step **D.** next

Main circuit board dial pot settings not correct. (If board has not been replaced.)

D. Check all pot settings on circuit board as shown in wiring diagram. (See adjustment section Traverse Motor Control Board Settings.)

Minimum and maximum pot settings effect traverse speed.

ELECTRICAL TROUBLESHOOTING (Continued)

PROBLEM--If the carriage traverses to one end of stroke or the other and it stops and does not reverse direction.

Possible Cause	Remedy	Reason
Proximity switch is not working properly or wire connections are loose	First check to see if proximity light comes on. When the light is on, it means that there is electricity coming to proximity switch. Actuate prox switches with steel tool to take measurements.	The light coming on shows the proximity is getting electrical contact.
	Left proximity (PROX1) check Traverse drive Control (TDC) between terminals #14 (black wire) and #15 (brown wire).	Proximity light on- 0 Volts DC Proximity light off- 12 Volts DC
	Right proximity (PROX) check (TDC) between terminals #13 (black wire) and #15 (brown wire).	Proximity light on- 0 Volts DC Proximity light off- 12 Volts DC
		Replace proximity switch if the voltages do not read as above.

PROBLEM--Insufficient hesitation at carriage stops prior to reversing traverse.

The dwell time on the traverse drive control not set properly.	Reset dwell time as required. One increment increases Dwell time by 1/2 second.
--	---

PROBLEM--Traverse changes directions erratically while running in traverse cycle.

Loose wire to proximity switch.	Check wire connections from the proximity switches and tighten down screws.	A loose wire connection will give intermittent electrical contact.
---------------------------------	---	--

ELECTRICAL TROUBLESHOOTING (Continued)

PROBLEM--Infeed motor not working.

Assuming (SSS) System Start Switch is on with 115 Volts AC to control panel and all other functions are working.

Possible Cause	Checkout Procedure	
Infeed Jog Switch (IJS) is not held to on position	A. (IJS) Hold switch on in either direction	Infeed motor works Yes--end troubleshooting No--go to Step B. next
Infeed Speed Switch (IJS) is not on high speed	B. Put (IJS) on high speed for ease of checkout	High speed works Yes--end troubleshooting No--go to Step C. next
Infeed motor/reducer drive coupling is loose	C. Open infeed motor coupling inspection plate to check for loose coupling. Retighten coupling to drive actuator screw. See adjustment section of manual.	Infeed works-- Yes--end troubleshooting No--go to Step D. next
No DC voltage to Grinding Wheel Infeed Motor (GIM)	D. Check for 12+ Volts DC across terminals labeled 2 and 5 of the (IJS) with (IJS) held on.	Check term 2 & 5 of (IJS) for 12+ Volts DC. Yes--go to Step E. next No--go to Step G. next
Infeed Motor/Reducer will not function	E. Check for 12 Volts DC at the (GIM) terminals	Check for 17 Volts DC at Term marked 73 GIMBL and 3 GIMRD. You will need jumpers to check. Yes--Go to Step F. next No--Replace cord wire no. 94
	F. Disconnect (GIM) from the infeed actuator and check (GIM) function under no load.	Check (GIM) function when disengaged from Infeed Actuator. Yes--Replaced Infeed Actuator No--Replace (GIM)
Switch (IJS) is bad	G. Check for 12+ Volts to (IJS).	Check for 12+ Volts DC at Term 6 & 4 and 3 & 1 of (IJS). Yes--Replace (IJS) No--go to Step H. next.
No DC Voltage from the Voltage Regulator.	H. Check for 12 volts DC at Bridge Diode output.	Check for 12 Volts DC at term 105BD1+ and 105BD1- Yes--Replace Voltage Regulator No--Go to Step I. next.

ELECTRICAL TROUBLESHOOTING (Continued)

PROBLEM--Infeed motor not working.

Assuming (SSS) System Switch is on with 115 volts AC to control panel and all other functions are working

Possible Cause	Checkout Procedure	
Bad Bridge Diode	I. Check Voltage	Check 12.6 Volts AC at input of Bridge Diode (BD1) Term (~) to Term (~) Yes--Replace Bridge Diode BD1 No--Go to Step W. next
No AC Voltage to the input side of transformer	J. Check for 115 Volts AC at transformer input black wires.	Check for 115 Volts AC at Term. 76 TFRBL and 76 TFRBL. You will need jumpers to check this. Yes-- Replace Transformer No--Check fuse FU3 and replace if needed. Follow separate trouble shooting procedure on AC main power.

MECHANICAL TROUBLESHOOTING (Continued)

PROBLEM--Actuator drive shaft whipping excessively at high traverse speed.

Possible Cause

Bearing were bolted down tightly with bearings putting a bow into the drive shaft.

Checkout Procedure

Loosen bearing blocks and check squareness of bearing collar face 90 degrees to carriage rods with a square and tighten down. The drive shaft to carriage front shaft is 2.875 +/- .010" (73 +/- .3mm) apart. See adjustment section for more information.

PROBLEM--Reels ground have high/low blades

Traverse Speed set too fast.

Check roundness using a magnetic base dial indicator. Traverse speed should be set approximately 12 ft/min. (4 meters/ min.) if roundness is varying.

Lineal bearings for the grinding head carriage are out of adjustment (loose) or have grit buildup causing uneven traversing load.

Relubricate and adjust linear bearings per adjustment section. If problem persists, replace lineal bearings on the carriage base. Check for any holes in the bellows that would permit any grinding grit penetration. See adjustment section for lineal bearing replacement.

PROBLEM--Excessive grinding stock being removed when traversing to the right in the relief grinding mode.

Gib adjustment for the relief finger assembly is loose so reel finger has movement. When traversing to the right minimum grinding stock removal should be seen as compared with heavy stock removal when traversing to the left.

Tighten the set screws for the gib adjustment. See procedure in the adjustment section in the manual.

PROBLEM-- Grinding stock removal from reel is irregular during spin grinding.

Lineal bearings on the grinding head carriage are too loose .

The lineal bearing must be preloaded to the traverse shafts with no vertical movement. See manual adjustment section for carriage linear bearing adjustments.

PROBLEM--Carriage traversing varies speed while grinding.

Oil on carriage drive shaft.

Wipe oil completely from the traverse shaft. Spray down with a spray lubricant (do not use a teflon based lubricant) and wipe off completely.

Lineal bearings in the carriage do not rotate freely.

Check for grinding grit getting into the lineal bearings and causing excessive driving torque of carriage. Abrasive noise is detectable when excessive grit is in the lineal bearings. Replace the four lineal bearings in the main carriage. Check bellows for holes and replace if necessary.

Actuator bearings are not rotating freely.

Check bearing for free rotation or flat spots on the bearing outside diameter. Replace the six bearings if necessary. See adjustment section for bearing replacement.

MECHANICAL TROUBLESHOOTING (Continued)

PROBLEM--Too heavy a burr on cutting edge of reel blades.

Possible Cause

Traverse speed set too high causing a heavy burr on the reel blade when spin grinding.

Checkout Procedure

Traverse speed should be set lower approximately 12 ft/min. (meters/min.) for a smaller burr on cutting edge.

PROBLEM--Cone shaped reel after grinding.

Grinding head travel not parallel to the reel center shaft.

Grinding head travel was not setup parallel to the reel center shaft in vertical and horizontal planes. See Align the Reel Section in operator's Manual

PROBLEM--Relief grind on the reel blades do not go the full length of the reel.

The right side corner of the grinding wheel is always to be in contact with the reel blade. This is high point of the relief finger.

The right hand side of the grinding wheel is not in full contact for relief grinding. See Operators Manual for NORMAL HELIX AND REVERSE HELIX for information of dressing the grinding wheel.

PROBLEM-- Traverse speed is too slow.

Possible Cause

Lineal bearing in the carriage are set too tight.

Remedy

A. Readjust bearings for proper tension. (for more detail see lineal bearing replacement in the adjustment section of the manual.)

Reason

When bearing preload is too tight, it causes excessive loading to drive the carriage.
When lineal actuator is disengaged, the proper traverse load 2 to 3 lbs. Use a tension scale to check. (A general guide only.)
NOTE: Check with linear actuator release

Actuator springs set too tight

B. Check to see if actuator bearings have been overloaded, causing the bearing to not rotate freely. (For more detail, see actuator setting in the adjustment section of the manual.

When actuator spring tension is excessive, bearings will not rotate freely causing carriage to not run freely. When the conical washers are too tight, it creates too much friction on the pivot points.

PROBLEM--Spin Drive cranks up and down too hard.

The two top and two bottom pivot screws are compressing the conical washer too tight.

A. Tighten down the locknut until it bottoms out and back off 1/2 turn. Check to see if there is a cone shape to the washer. Four (4) pivot points.

Check screw adjustment tension on nylon plug riding against the screw thread.

B. Loosen set screw and check. (See adjustment section.)

Have enough play so the crank turns snugly but during operation it is free.

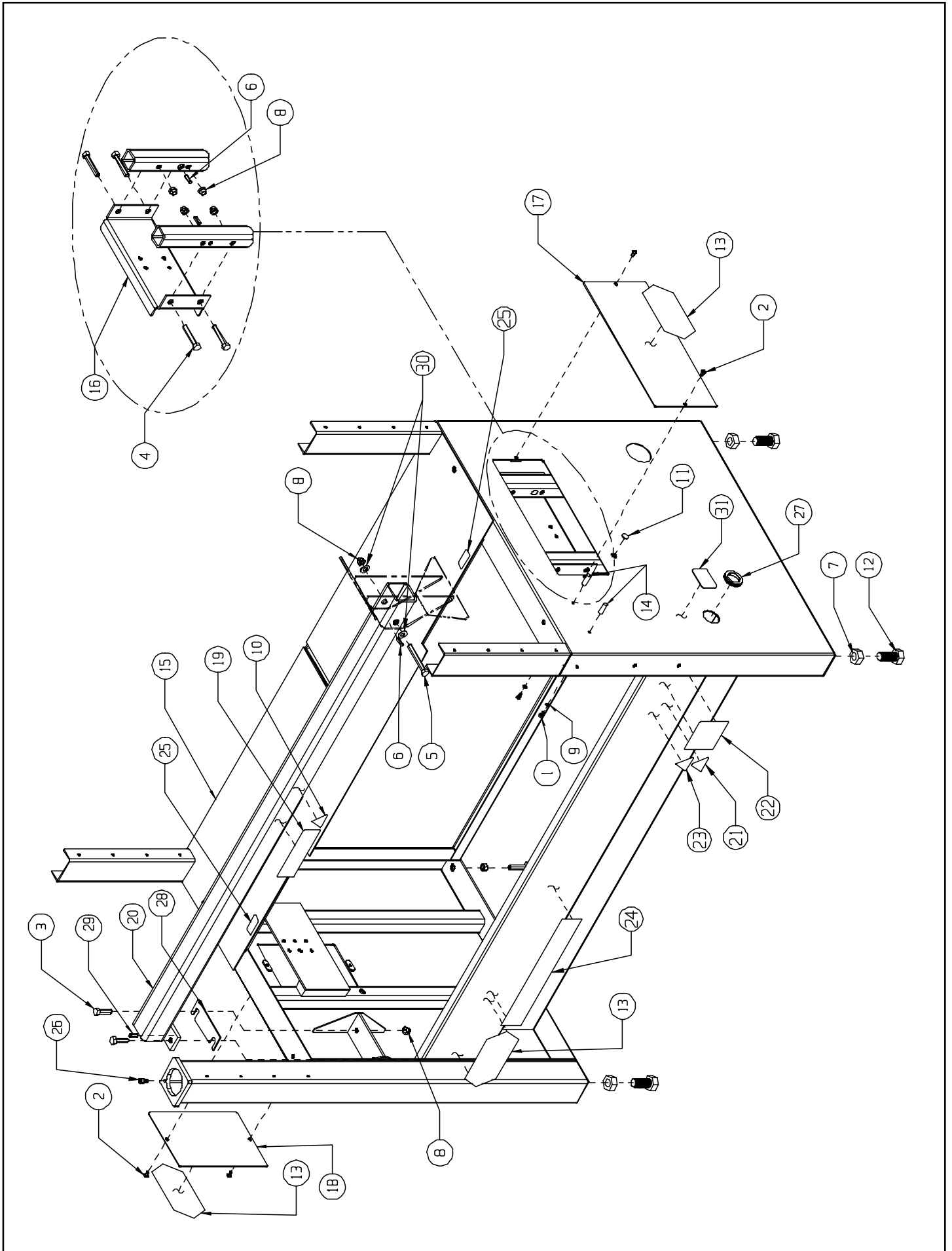

<u>DIAGRAM NUMBER</u>	<u>PART NUMBER</u>	<u>DESCRIPTION</u>
1	B251001	Hex Head Cap Screw 1/4-20 x 5/8
2	B310813	Button Head Socket Cap Screw 5/16-18 x 1/2
3	B502801	Hex Head Cap Screw 1/2-13 x 1 3/4
4	B504801	Hex Head Cap Screw 1/2-13 x 3
5	B506801	Hex Head Cap Screw 1/2-13 x 4.25
6	H371602	Roll Pin .375 Dia. x 1.00 Long
7	J992000	1-8 Hex Jam Nut
8	J507100	1/2-13 Locknut
9	K251501	1/4 Split Lockwasher
10.....	3708612	Warning Decal - No Fuel
11	3708542	Black Hole Plug .625 Dia.
12.....	A993201	Adjustable Leveling Bolt
13.....	3709990	Large Foley United Decal
14.....	6309039	Gage Pin Mounting
15.....	6309523	Main Gage Weldment
16.....	6509035	Frame Adjuster Mounting
17.....	6509039	Right-Hand Access Panel
18.....	6509040	Left-Hand Access Panel - Small
19.....	6509116.....	Fuel Warning Decal
20.....	6509510	Tooling Bar Weldment
21	3708606	Warning Decal - Hearing Protection
22.....	3708703	Warning Decal - Safety Symbol
23.....	3708605	Warning Decal - Respirator Symbol
24.....	6709101	Decal - Accu Pro
25.....	6309111	Decal - Up/Down
26.....	B370811	Socket Head Cap Screw 3/8 - 16 x 1/2
27	3708375	Grommet
28.....	6309389	Tooling Bar Shim
29.....	H372002	Roll Pin 3/8 Dia. x 1" Long
30.....	K500001	1/2 Flat Washer

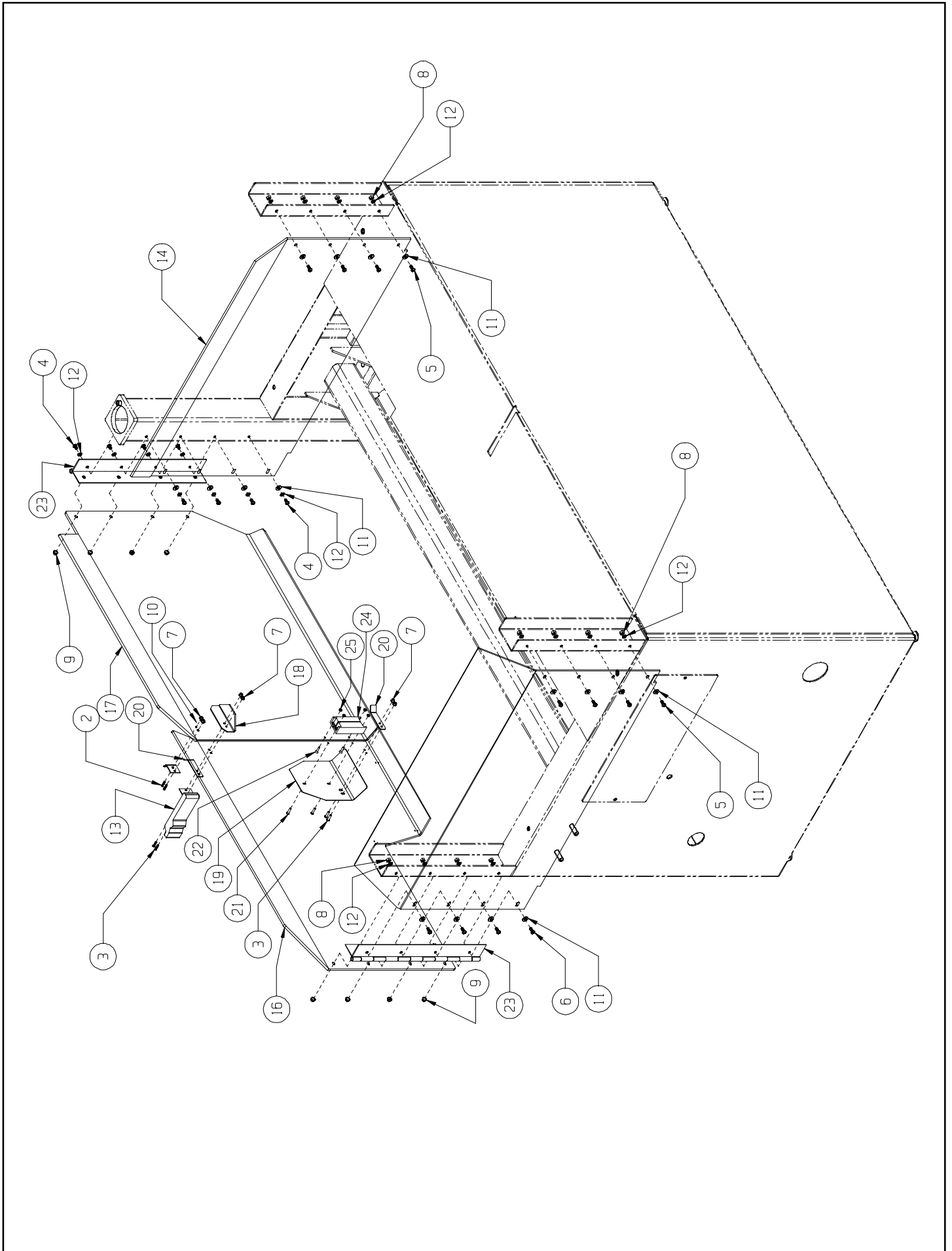

DIAGRAM NUMBER	PART NUMBER	DESCRIPTION
2	B191011	Socket Head Cap Screw 10 - 24 x 5/8
3	B191211	Socket Head Cap Screw 10 - 24 x 3/4
4	B250818	Pan Head Machine Screw 1/4 - 20 x 1/2
5	B251018	Pan Head Machine Screw 1/4 - 20 x 5/8
6	B251218	Pan Head Machine Screw 1/4 - 20 x 3/4
7	J197100	10-24 Full Nylon Locknut
8	J251000	Hex Nut 1/4 - 20
9	J257000	1/4-20 Thin Locknut
10	K190001	#10 Flat Washer
11	K250001	1/4 Flat Washer
12	K251501	1/4 Split Lockwasher
13	3708416	Soft Latch
14	6309028	Left-Hand Panel Guard
15	6309029	Right-Hand Panel Guard
16	6309194	Right-Hand Door Guard
17	6309193	Left-Hand Door Guard
18	6309033	Door Bracket Rear
19	6309124	Door Front Plate
20	6309038	Door Bracket Front
21	3708819	#8-32 Button Head Safety Screw
22	3707585	#8-32 Flat Head Safety Screw
23	6309527	Guard Door Hinge Assembly
24	6309107	Door Safety Switch Assembly
25	J167000	#8 Locknut Jam

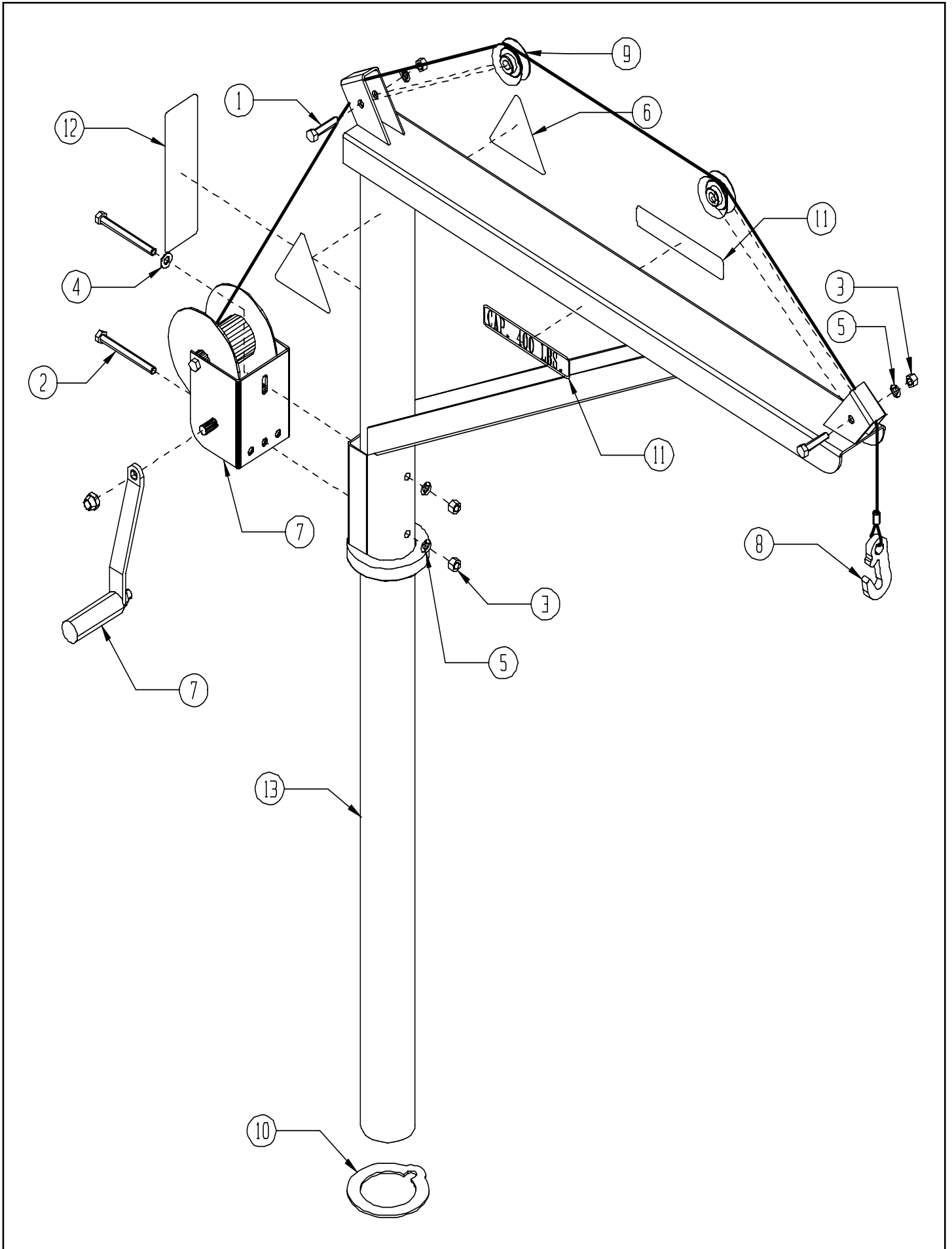
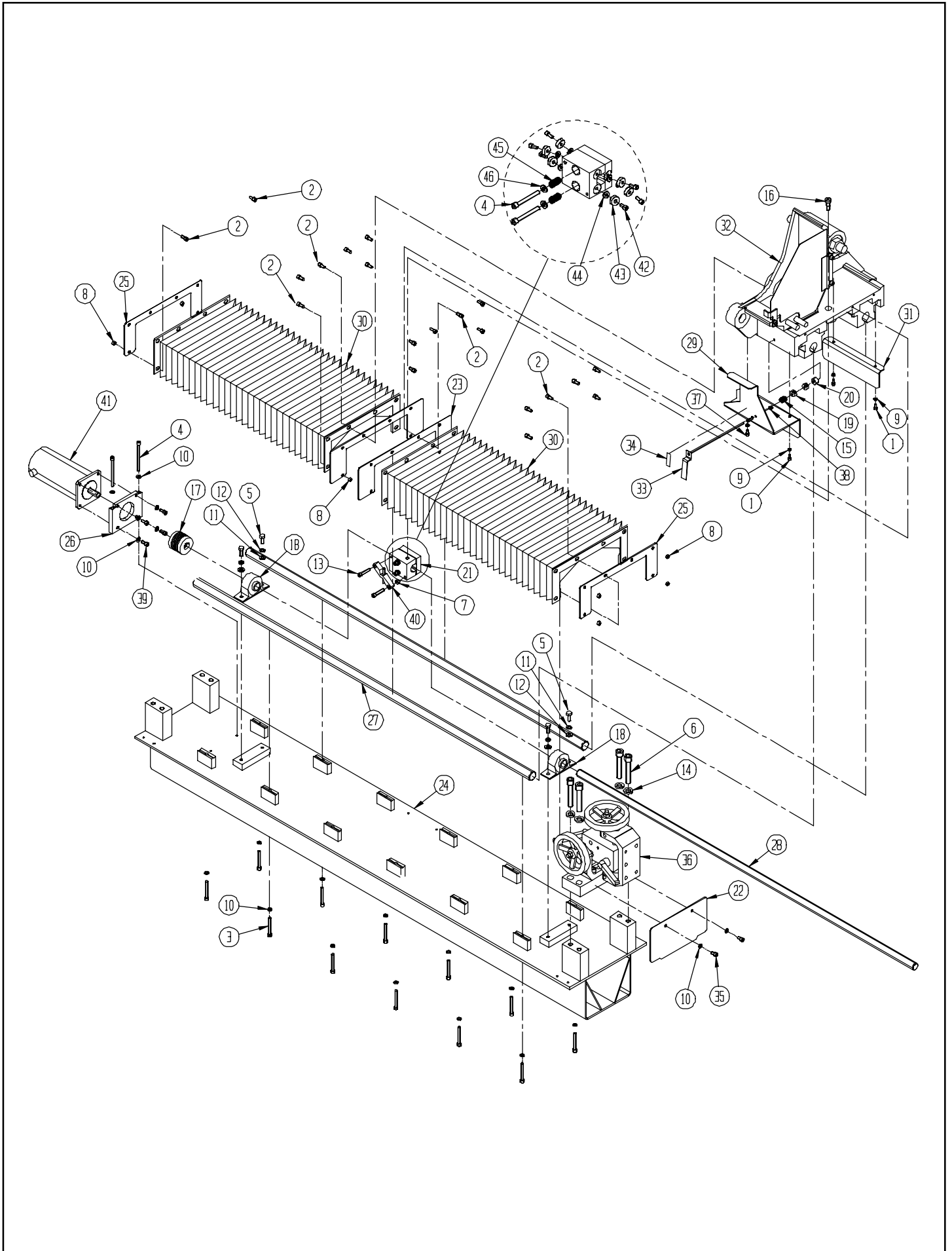

DIAGRAM NUMBER	PART NUMBER	DESCRIPTION
1	B372801	Hex Head Cap Screw 3/8-16 x 1-3/4
2	B376401	Hex Head Cap Screw 3/8-16 x 4.0
3	J371000	3/8-16 hex Nut
4	K370001	3/8 Flat Washer
5	K371501	3/8 Split Lockwasher
6	3708456	Warning Decal - Boom Capacity
7	3708578	Winch
8	3709407	Hook and Cable Assembly
9	3709795	Pulley
10	6309009	Rotation Thrust Washer
11	6309036	Boom Capacity Decal
12	6309037	Winch Warning Decal
13	6309535	Boom Weldement

PARTS LIST 6309510-(Bottom) TRAVERSE AND CARRIAGE ASSEMBLY



PARTS LIST 6309510-(Bottom) TRAVERSE AND CARRIAGE ASSEMBLY

<u>DIAGRAM NUMBER</u>	<u>PART NUMBER</u>	<u>DESCRIPTION</u>
1	B190611	Socket Head Cap Screw 10-24 x 3/8 Long
2	B250819	Button Head Socket Cap Screw 1/4-20 x 1/2 Long
3	B253211	Socket Head Cap Screw 1/4-20 x 2 Long
4	B255211	Socket Head Cap Screw 1/4-20 x 3.25 Long
5	B311201	Hex Head Cap Screw 5/16-18 x 3/4 Long
6	B503211	Socket Head Cap Screw 1/2-13 x 2 Long
7	J251000	1/4-20 Hexnut
8	J257100	1/4-20 Nylok Locknut
9	K191501	No. 10 Washer
10	K251501	1/4 Split Lockwasher
11	K310001	5/16 Flatwasher
12	K311501	5/16 Split Lockwasher
13	B252011	Socket Head Cap Screw 1/4-20 x 1 1/4 Long
14	K501501	1/2 Split Lockwasher
15	3619224	Compression Spring
16	3708147	Shoulder Bolt .375 Dia. x .625 Long
17	3709583	Flexible Coupling
18	3709635	Pillow Block Bearing
19	6009152	Shaft Collar
20	6009153	Rubber Washer
21	6509343	Actuator Assy.
22	6509020	Traverse Base Adjustable End Cap
23	6509021	Bellows Carriage Mounting Bracket
24	6509024	Machined Traverse Base
25	6509025	Bellows End Mounting Bracket
26	6509061	Motor Mount Bracket
27	6509063	Carriage Shaft
28	6509065	Carriage Drive Shaft
29	6509211	Carriage Proximity Flag Bracket
30	6509250	650 Way Cover Bellows
31	6509253	Carriage Dust Cover Bracket
32	6509566	Carriage Sub Assembly
33	6509585	Release Arm Weldment
34	3708454	Release Decal
35	B250616	Button Head Cap Screw 1/4-20 x 3/8
36	6509565	Cross Slide Sub Assembly
37	B190811	Socket Head Cap Screw 10-24 x 1/2 Long
38	J197000	10-24 Locknut - Jam
39	B251211	Socket Head Cap Screw 1/4-20 x 3/4 Long
40	6009548	Actuator Bar Assembly
41	6309085	Traverse Motor Assy
42	3709668	Socket Head Screw
43	3709597	Sealed Bearing
44	3709596	Spacer
45	3709469	Compression spring
46	K250001	1/4" Flat Washer

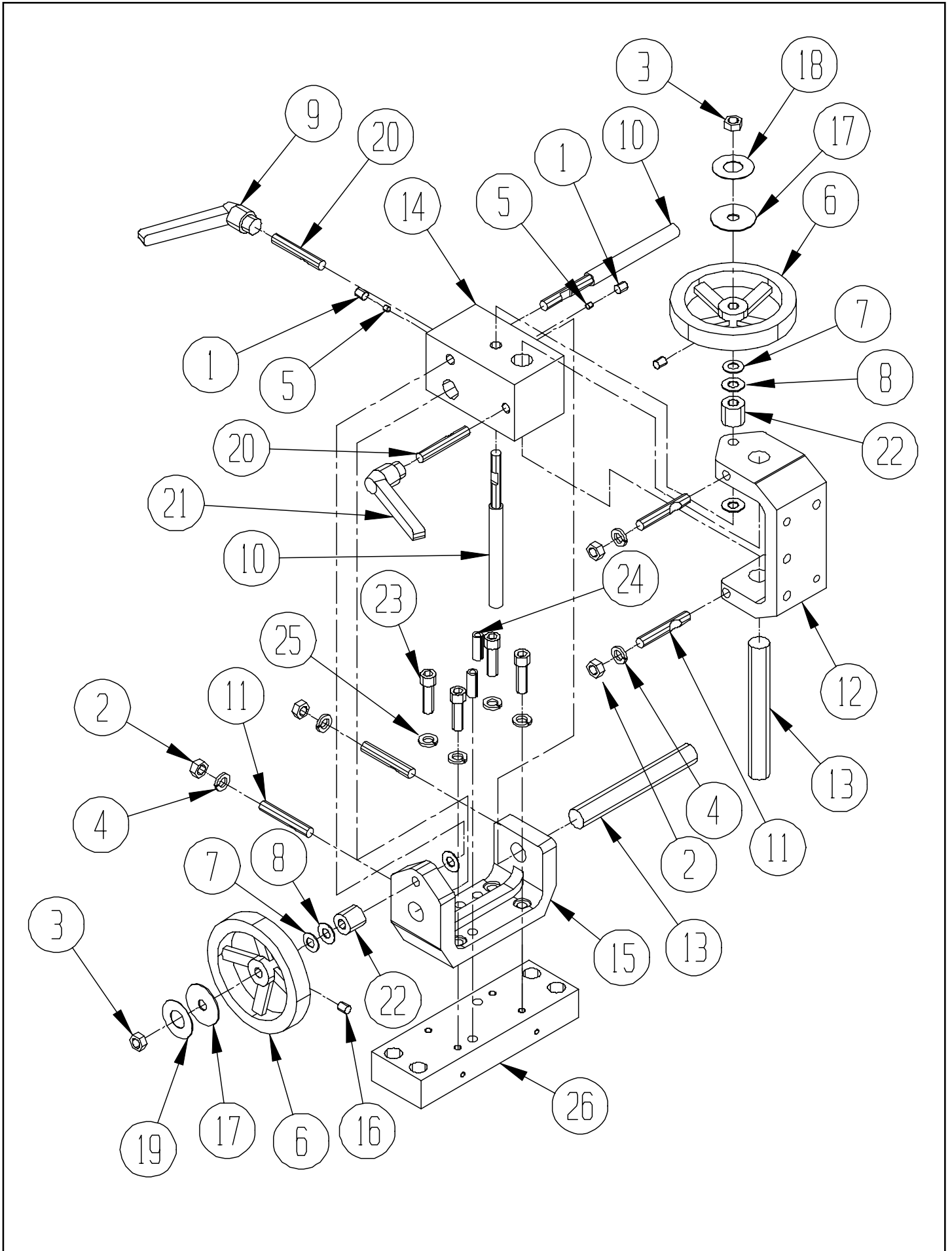

PARTS LIST

6509565 CROSS SLIDE ASSEMBLY

<u>DIAGRAM NUMBER</u>	<u>PART NUMBER</u>	<u>DESCRIPTION</u>
1	C311220	Socket Set Screw CPPT 5/16-18 x 3/4 Long
2	J371000	3/8-16 Hex Nut
3	J377000	3/8-16 Hex Jam Nylon Locknut
4	K371501	3/8 Split Lockwasher
5	3579109	3/16 Dia. Nylon Plug
6	3708148	Handwheel 4.5 Dia. .38 Bore
7	3709062	Bell V Washer .75 O. D. x .035 T
8	3709304	Thrust Washer
9	3708705	Adjustable Handle 5/16-18 Female - Orange
10	6509390	Adjusting ACME Shaft
11	6009035	Locking Stud Shaft
12	6009082	Cross Slide Support
13	6009095	Slide Shaft
14	6509011	Cross Slide
15	6509015	Cross Slide Horizontal support
16	C310820	Socket Set Screw 5/16-18 x 5/8 Long
17	3708665	Flat Washer
18	6309115	Grey Decal
19	6309114	Orange Decal
20	6309113	5/16-18 Locking Stud
21	3708706	Adjustable Handle 5/16-18 Female - Grey
22	3969065	Spacer .406 ID x .75 OD x 1.0 Long
23	B372011	Socket Head Cap Screw 3/8-16 x 1 1/4 Long
24	H371602	Rollpin 3/8 Dia. x 1 Long
25	K371501	3/8 Split Lockwasher
26	6509010	Traverse Base Adjuster Bracket

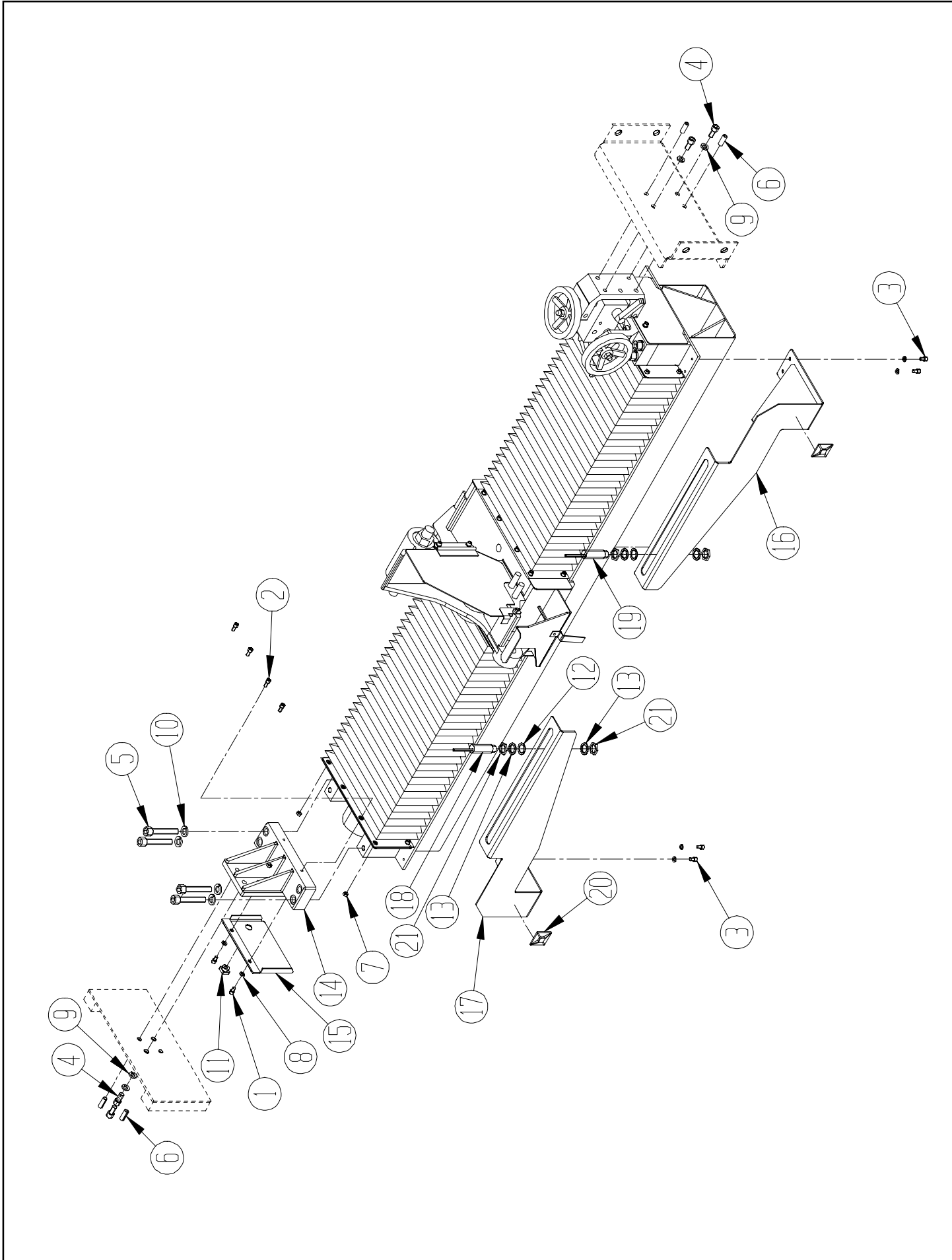

PARTS LIST**6309530 TRAVERSE AND CARRIAGE ASSEMBLY**

<u>DIAGRAM NUMBER</u>	<u>PART NUMBER</u>	<u>DESCRIPTION</u>
1	B250811	1/4-20 Socket Head Cap Screw x 1/2" Long
2	B250819	1/4" Truss Head Machine Screw x 1/2" Long
3	B251011	1/4-20 Socket Head Cap Screw x 5/8" Long
4	B371211	3/8-16 Socket Head Cap Screw x 3/4" Long
5	B503211	1/2-13 Socket Head Cap Screw x 2" Long
6	H371602	3/8" Dia. Roll Pin x 1" Long
7	J257100	1/4-20 Full Height Locknut
8	K251501	1/4 Lockwasher
9	K371501	3/8 Lockwasher
10	K501501	1/2 Lockwasher
11	3707279	Strain Relief
12	3708419	Wave Spring
13	3708421	Flat Washer - 3/4 ID x 1 OD x .075Thick
14	6509221	Fixed Traverse Base Bracket
15	6509553	Fixed End Cap Weldment
16	6509560	RH Proximity Switch Bracket Weldment
17	6509561	LH Proximity Switch Bracket Weldment
18	6309056	LH Traverse Proximity Switch
19	6309057	RH Traverse Proximity Switch
20	3707224	Cable Tie Mount (Used Throughout Machine)
21	3707459	Proximity Switch Nut

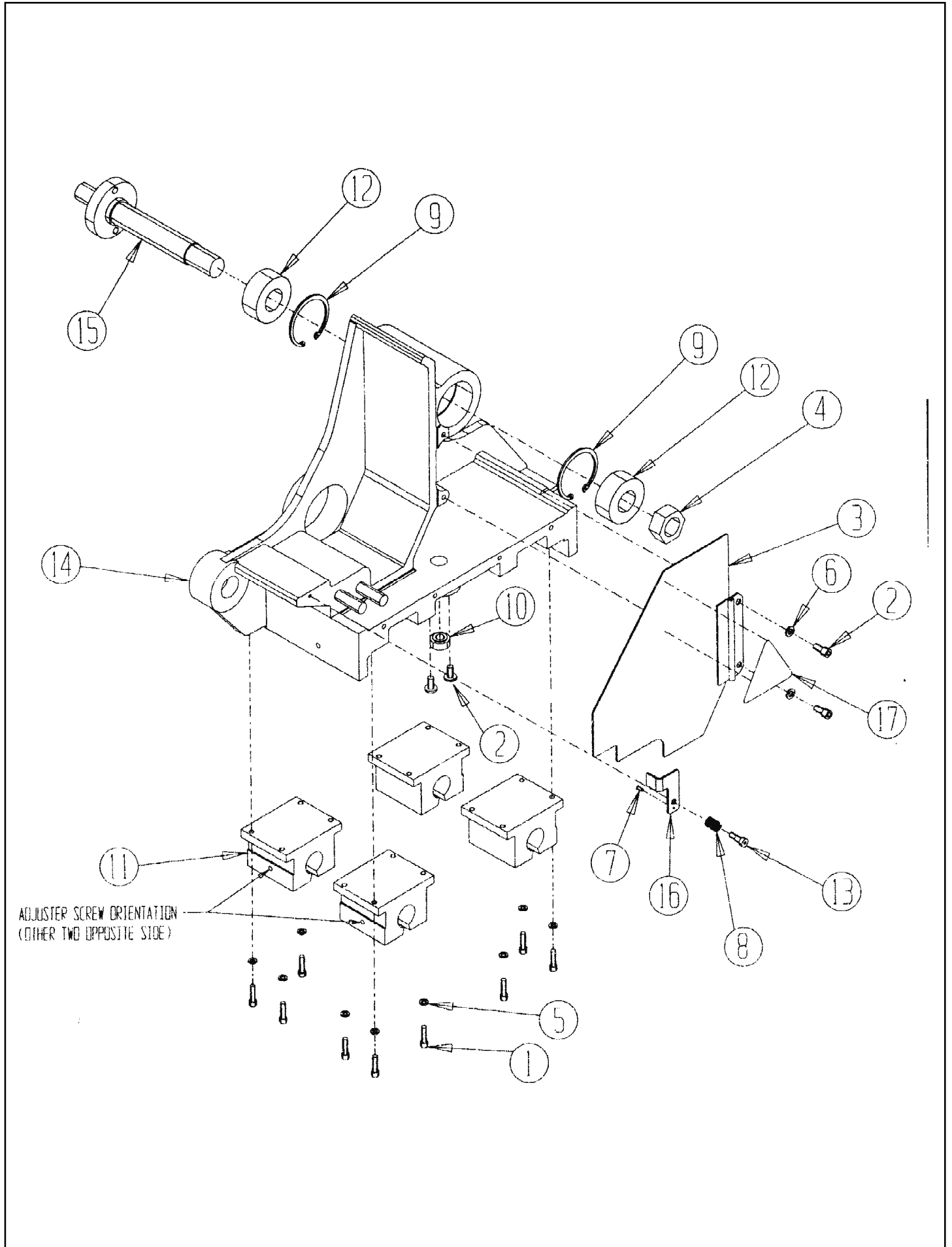

<u>DIAGRAM NUMBER</u>	<u>PART NUMBER</u>	<u>DESCRIPTION</u>
1	B191211	Socket Head Cap Screw 10-24 x 3/4 Long
2	B250616	BS Head Cap Screw 1/4-20 x .38 Long
3	6509584	Swing Door Weldment
4	J887300	7/8-14 Nylok Jam Locknut
5	K191501	No. 10 Lockwasher
6	K251501	1/4 Split Lockwasher
7	R602031	#4 x .31 Drive Screw
8	3708105	Compression Spring
9	3708184	Retaining Ring
10	3709040	Spherical Bearing
11	3709044	Ball Bushing Bearing
12	3708186	Ball Bearing
13	3708208	Shoulder Bolt .250 Dia. x .387 Long
14	6509019	Carriage Base
15	6509023	Grinder Head Pivot Shaft
16	6509251	Swing Door Latch
17	3708462	Decal - RPM, Symbol

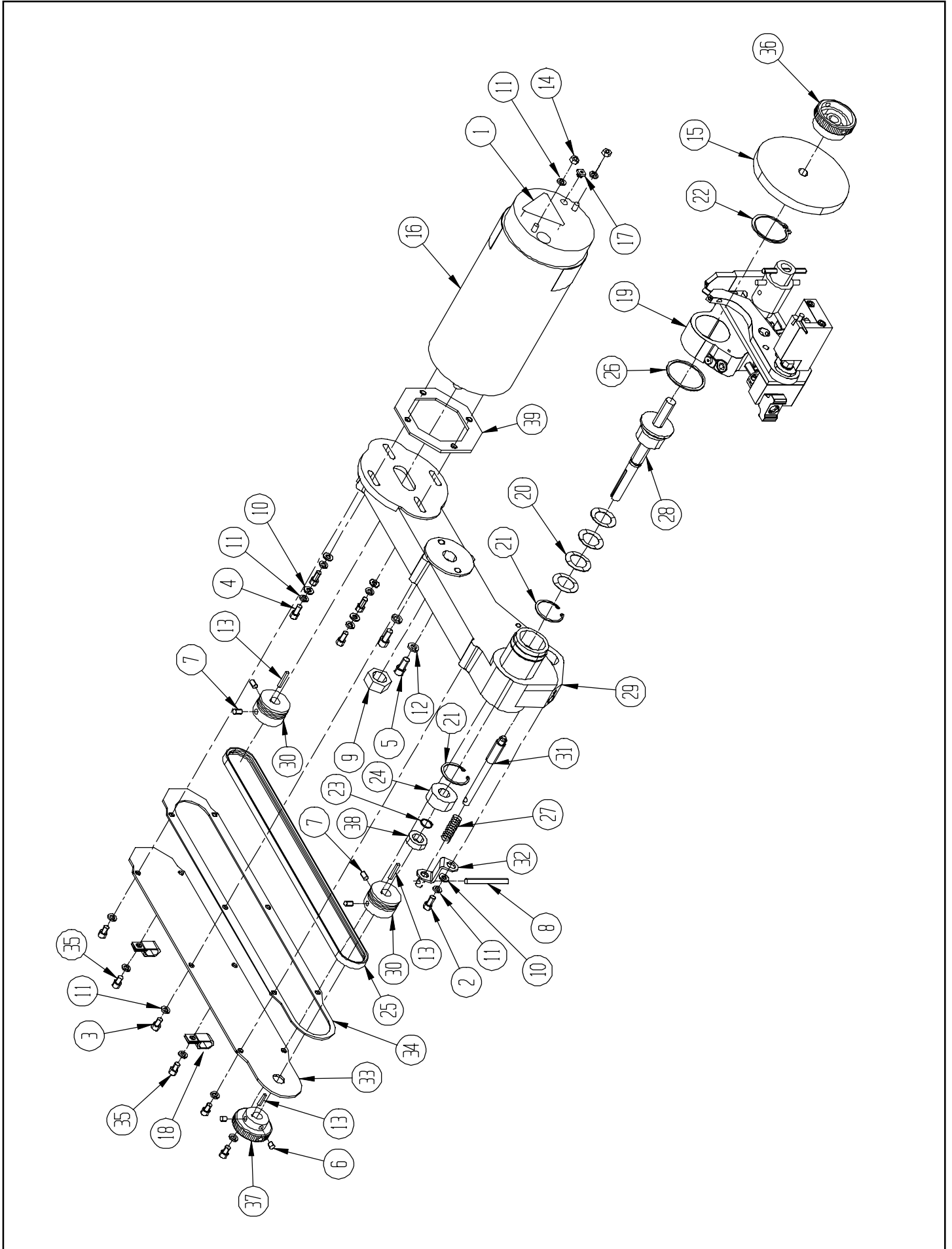

PARTS LIST**6309510-(Top) TRAVERSE & CARRIAGE ASSEMBLY**

<u>DIAGRAM NUMBER</u>	<u>PART NUMBER</u>	<u>DESCRIPTION</u>
1	3708448	Warning Electric Symbol
2	B250811	Socket Head Cap Screw 1/4-20 x 1/2 Long
3	B250818	Pan Head Machine Screw 1/4-20 x 1/2 Long
4	B251611	Socket Head Cap Screw 1/4-20 x 1 Long
5	B311611	Socket Head Cap Screw 5/16-18 x 1 Long
6	C250420	Socket Set Screw 1/4-20 x 1/4 Long
7	C250627	Socket Set Screw 1/4-20 x 3/8 Long Nylon Patch
8	H184002	Roll. Pin 3/16 x 2.5 Long
9	J757300	3/4-16 Full Nylok Locknut
10	K250001	1/4Flat washer
11	K251501	1/4 Split Lockwasher
12	K311501	5/16 Split Lockwasher
13	R000376	Square Key 1/8 x 3/4" Long
14	J257100	1/4-20 Locknut
15	3700089	Grinding Wheel 5" Dia. x 1" Wide
16	3707023	DC Motor 1 HP 90V
17	3707294	Strain Relief
18	3707935	Tube Clamp
19	6309573	Finger Sub Assembly
20	3708193	Conical Washer
21	3708194	Internal Retaining Ring 5000-137
22	3708195	External Retaining Ring 5100-187
23	3708196	Internal Retaining Ring 5100-59
24	3708204	Ball Bearing
25	3708202	Poly V Belt
26	3708436	Wave Spring
27	3709072	Compression Spring
28	6509578	Grinding Head Spindle Assembly
29	6509018	Grinding Head Housing
30	6509052	Poly V Pulley
31	6509484	Plunger Pin
32	6509054	Plunger Pin Retainer
33	6509055	Belt Cover
34	6509210	Belt Cover Gasket
35	B251018	Pan Head Machine Screw 1/4-20 x 5/16 Long
36	6509237	Grinding Wheel Knob
37	6509238	Grip Grinding Wheel Knob
38	6509247	Pulley Spacer
39	6509256	Motor Spacer

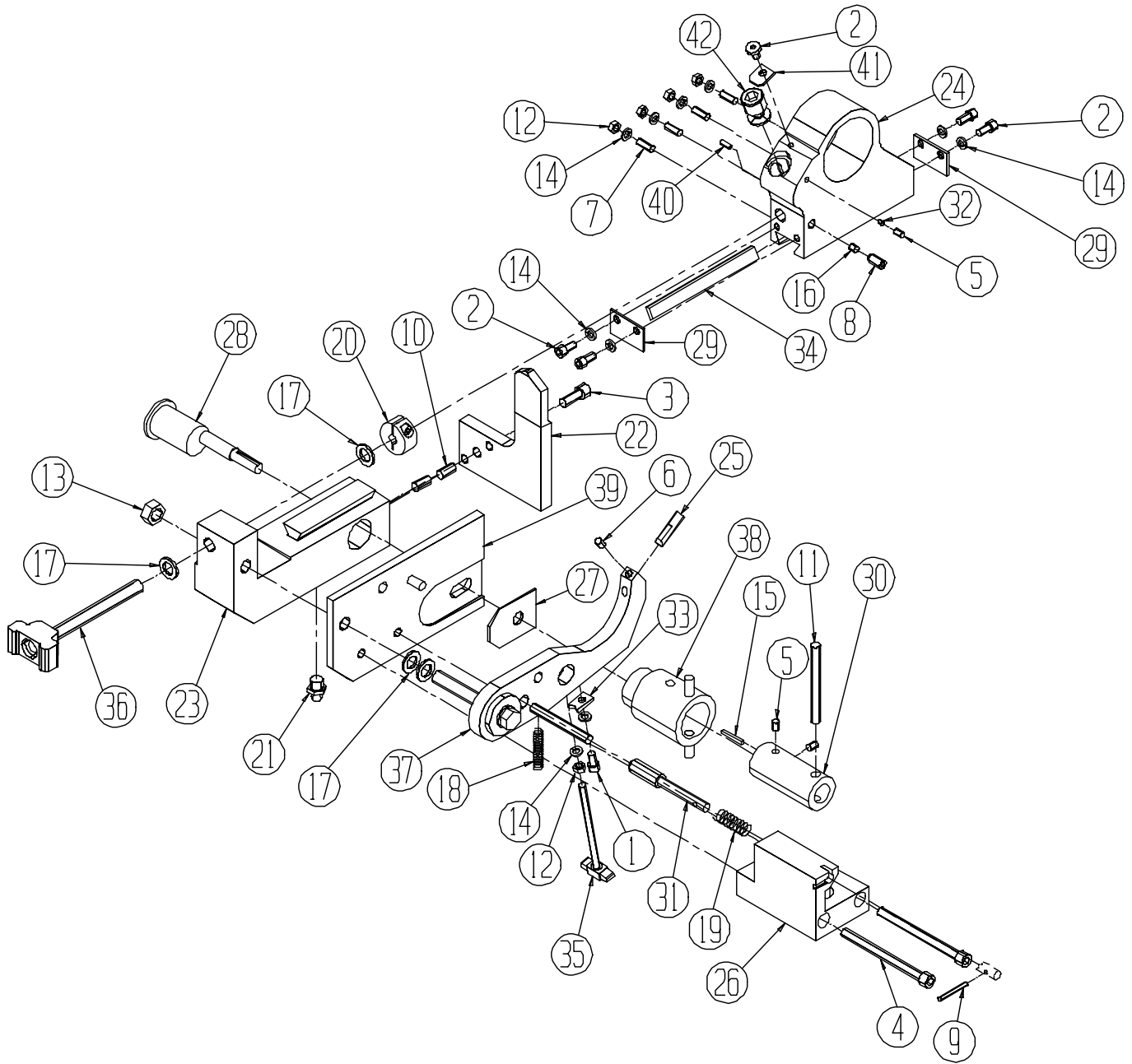

<u>DIAGRAM NUMBER</u>	<u>PART NUMBER</u>	<u>DESCRIPTION</u>
1	B190631	Socket Head Cap Screw 10-32 x 3/8 Long
2	B190634	Button Head Socket Cap Screw 10-32 x 3/8 Long
3	B251011	Socket Head Cap Screw 1/4-20 x 5/8 Long
4	B254811	Socket Head Cap Screw 1/4-20 x3 Long
5	C190460	Socket Set Screw 10-24 x 1/4
6	C190467	Socket Set Screw - Nylok Cup 10-32 x .25 Long
7	C190860	Socket Set Screw - CP-PT 10-32 x 1/2 Long
8	C190860	Socket Set Screw - 10-32 x 1/2 Long
9	H122002	Roll Pin 1/8 Dia. x 1 1/4 Long
10	H250813	Dowel Pin 1/4 Dia. x .5 Long
11	H254009	Drive Lock Pin 1/4 x 2.5 Long
12	J191100	10/32 Hex Nut
13	J377200	3/8-24 Jam Nylok Locknut
14	K191501	No. 10 Lock Washer
15	R000351	Square Key .093 x .75 Long
16	3579284	1/8 Dia. Nylon Plug
17	3709304	Thrust Washer
18	3708107	Compression Spring
19	3708175	Compression Spring
20	3708199	3/8-16 Dia. Split Shaft Collar
21	3709472	Straight Grease Fitting
22	6509432	Relief Finger
23	6509004	Reel Finger Slide
24	6509357	Reel Finger Positioner
25	6509007	Index Stop Pin
26	6509008	Index Sensor Block
27	6509009	Slide Washer
28	6509058	Eccentric Index Pin
29	6509060	Gib Stop Plate
30	6509215	Adjustable Index Lever
31	6509229	Locking Index Finger Pin
32	3579284	1/8" Diameter Nylon Plug
33	6509239	Anti Rotation Plate
34	6509258	Dovetail Gib
35	6509501	Tee Knob Assembly
36	6509547	Knob Assembly
37	6509572	Index Finger Assembly
38	6509591	Index Lock Handle Weldment
39	6509592	Index Finger Positioner Weldment
40	H120402	1/8" Diameter x 1/4" Long Pin Roll
41	6509358	Stop Plate
42	6509356	Reel Positioner Adjuster

PARTS LIST

6309574 STEPPER & MOUNTING ASSEMBLY

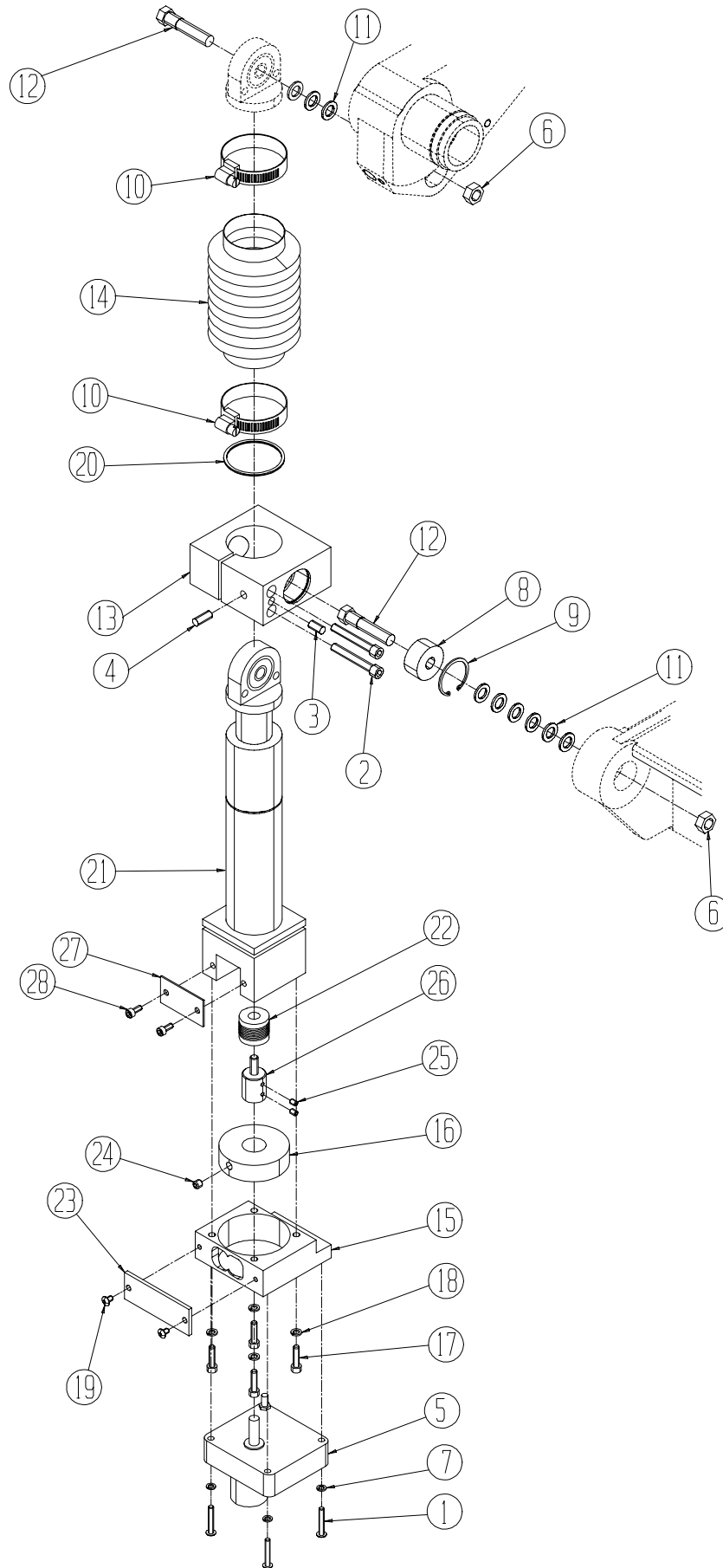

<u>DIAGRAM NUMBER</u>	<u>PART NUMBER</u>	<u>DESCRIPTION</u>
1	B161811	Socket Head Cap Screw 8-32 x 1 1/8 Long
2	B252811	Socket Head Cap Screw 1/4-20 x 1 3/4 Long
3	C250825	Socket Set Screw 1/4-20 x 1/2
4	C251020	1/4-20 x 5/8" Set Screw
5	6309500	DL Motor/Reducer Assembly
6	J377200	3/8-24 Nylok Jam Locknut
7	K161501	#8 Split Lockwasher
8	3708187	Ball Bearing
9	3708189	Retaining Ring
10	3708192	Hose Clamp 2.25 Dia.
11	3709304	Thrust Washer
12	6509048	Hex Pivot Pin
13	6509051	Trunion Block
14	6509056	Bellows, 1.88 I.D.
15	6309052	Actuator Motor Mounting Bracket
16	6309053	Calibration ring
17	B191611	Socket Head Cap Screw 10-24 x 1" Long
18	K191501	#10 Lockwasher
19	B160407	8-32 x 1/4 Button Head Socket Cap Screw
20	3708424	Retaining Ring Ext. 1.75
21	6509384	Infeed Stepper Assembly
22	3708629	Split Shaft Collar .25 I.D.
23	6309055	Window
24	C250420	1/4-20 x 1/4 Socket Set Screw
25	C160420	8-32 x 1/4 Socket Set Screw
26	6309040	Adapter
27	6509381	Base Cover Plate
28	B190613	Socket Head Cap Screw 10-24x 3/8 Long

PARTS LIST

6309541 CONTROL PANEL ASSEMBLY

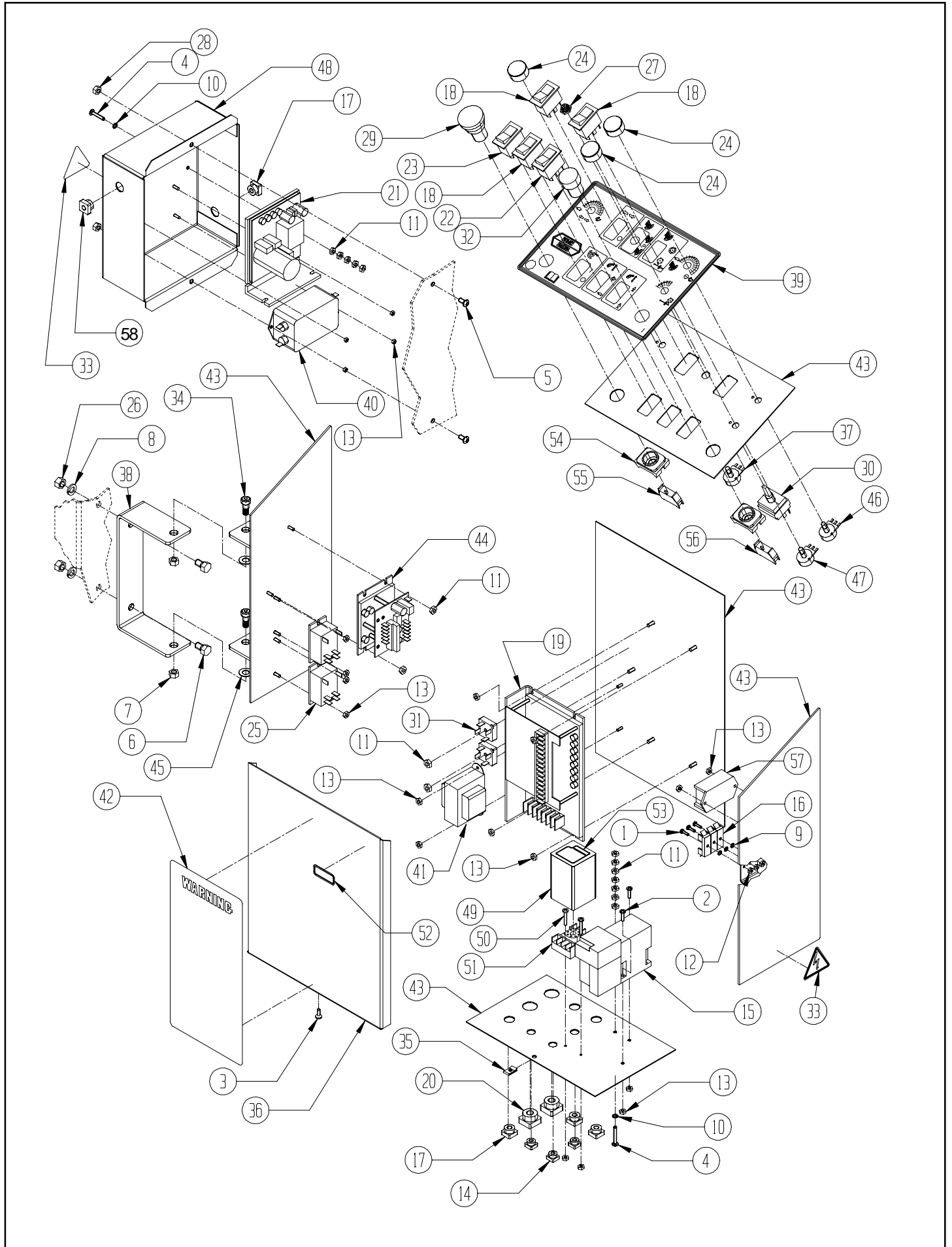

PARTS LIST

6309541 CONTROL PANEL ASSEMBLY

<u>DIAGRAM NUMBER</u>	<u>PART NUMBER</u>	<u>DESCRIPTION</u>
1	B130812	Pan Head Machine Screw 6-32 x 1/2
2	B161014	Pan Head Machine Screw 8-32 x 5/8
3	B190809	Round Head Machine Screw 10-24 x 1 1/2
4	B192013	Button Head Cap Screw 10-24 x 1.25
5	B250816	Button Head Cap Screw 1/4-20 x 1/2
6	B371201	Hex Head Cap Screw 3/8-16 x 3/4
7	J317100	Locknut 5/6-18
8	K371501	3/8 Split Lockwasher
9	R000480	Lockwasher #8
10	R000483	Lockwasher #10
11	R000553	Kep Nut 10-24
12	R000557	Kep Nut 6-32
13	R000558	Kep Nut 8-32
14	3707066	Strain Relief .22/.23 Wire
15a	3707556	Magnetic Starter 1 HP
15b	3707557	Overload Relay for Starter
16	3707091	Fuse Block
17	3707273	Strain Relief .33/.36 Wire
18	3707367	Rocker Switch On/Off
19	3707550	Traverse Control Board
20	3707275	Strain Relief .33/.36 Wire
21	3707314	Control Board 1 HP
22	3707428	Rocker Switch On/Off/On
23	3707429	Rocker Switch On/Off
24	3707446	Knob with Pointer
25	3707431	Relay 24VDC Coil
26	J371000	Hex Nut 3/18-16
27	3707075	Boot - Toggle Switch
28	R000552	Kep Nut 1/4-20
29	3707567	Stop Push-Pull Button
30	3707080	Switch - Toggle Hes/Rev
31	3707526	Bridge Diode - 25AMP
32	3707564	Start Pushbutton
33	3708448	Electrical Warning Decal
34	3709809	Shoulder Bolt .375D x .375L
35	3709864	Tinnerman Nut
36	6009062	Electrical Box Cover
37	6009199	Traverse Pot Assembly
38	6709068	Box Painted Pivot Bracket
39	6309047	Control Panel Decal
40	3707403	Power Line Filter
41	6309511	Transformer Assembly
42	6709091	Warning Decal
43	6309502	Control Box Weldment
44	3707524	Spin Drive Control Board
45	3709304	Thrust Washer .375 x .812
46	6309065	Spin Pot Assembly
47	6309066	Torque Release Pot Assembly
48	6309516	Control Board box Weldmen
49	3707558	Voltage Sensor
50	B161614	#8-32 x 1" PHMS
51	3707073	8 Pin Socket
52	3708697	Decal - Patent
53	3708826	Decal - Low Voltage
54	3707566	Contactormounting Latch
55	3707568	Contactormounting Stop Button
56	3707565	Contactormounting Start Button
57	6309105	Voltage Regulator Assembly
58	3707294	Strain Relief .43/.47 Wire

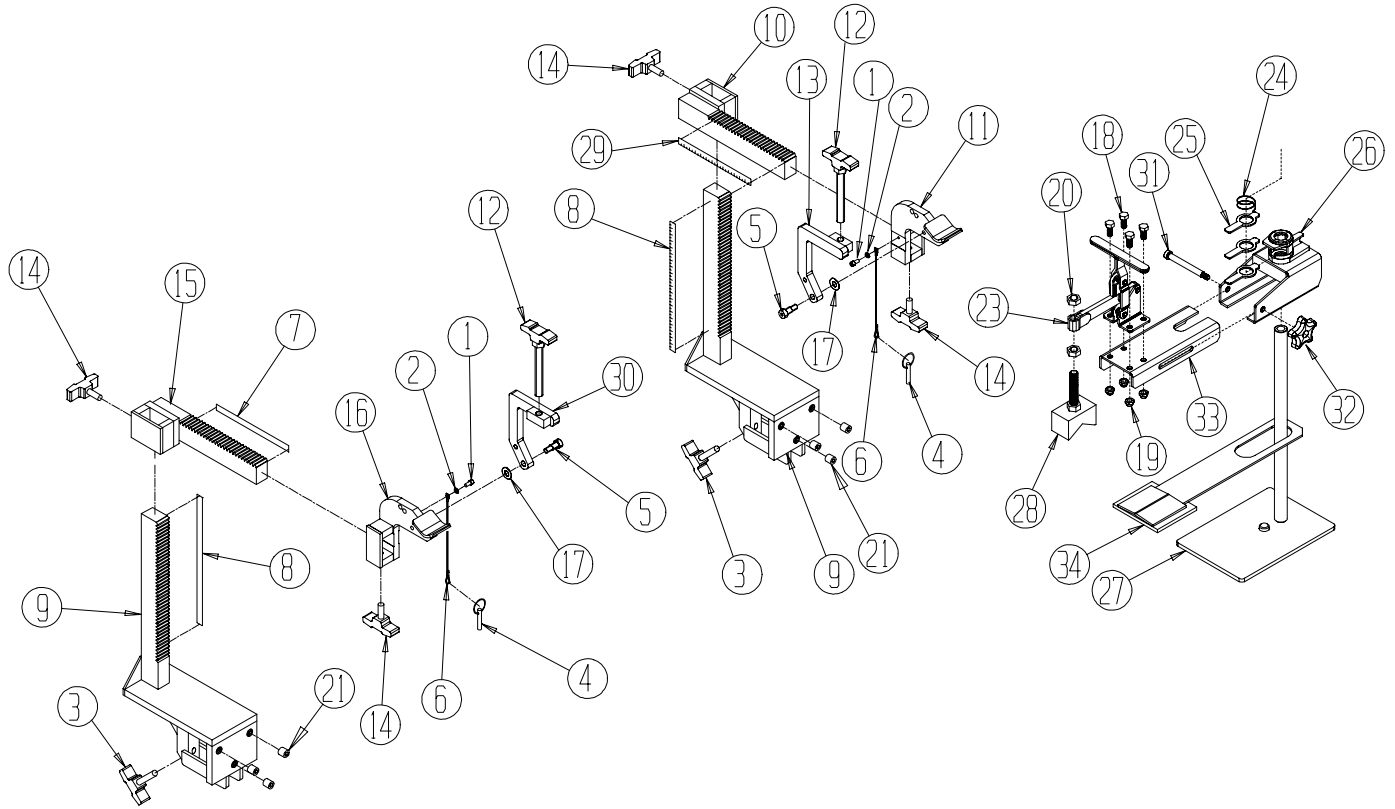

<u>DIAGRAM NUMBER</u>	<u>PART NUMBER</u>	<u>DESCRIPTION</u>
1	B190614	Pan Head Machine Screw 10-24 x 3/8 Long
2	K191501	No.10 Lockwasher
3	6009577	Knob Assembly
4	3708364	Quick Release Pin .31 Dia.
5	3708158	Shoulder Bolt .375 Dia. x .50 Long
6	3708366	6" type B Lanyard
7	6509128	Horizontal Scale Decal RH
8	6509129	Vertical Scale Decal
9	6509507	Bar Mounting Weldment Bracket
10	6509517	L.H. Front Roller Horiz. Weldment Bracket
11	6509422	L. H. Roller Clamp Weldment Bracket
12	6509559	Knob Assembly
13	6509564	L.H. Front Roller Clamp Weldment
14	6509588	Knob Assembly
15	6509515	R.H. Front Roller Horiz. Weldment Bracket
16	6509421	R.H. Roller Clamp Weldment Bracket
17	3709304	Thrust Washer
18	B311201	Hex Head Cap Screw 5/16-18 x 3/4 Long
19	J317100	5/16-18 Nylok Locknut
20	J507000	1/2-13 Hex Jam Nut
21	C500861	1/2-20 x 1/2 Flat Pt Socket Head Set Screw
23	6309534	Toggle Clamp
24	3709849	Pony Clamp Spring
25	3709858	Pony Leaf
26	6309532	R.R. Clamp Arm Weldment
27	6309536	R.R. Clamp Base Weldment
28	6509545	R.R. Clamp Block Weldment
29	6509304	Horizontal Scale Decal LH
30	6509576	R.H. Front Roller Clamp Weldment
31	3708579	Shoulder Bolt .375 x 3.25 Long
32	3709613	Star Knob
33	6309022	Slide
34	6309544	Rear Roller Bracket Weldment

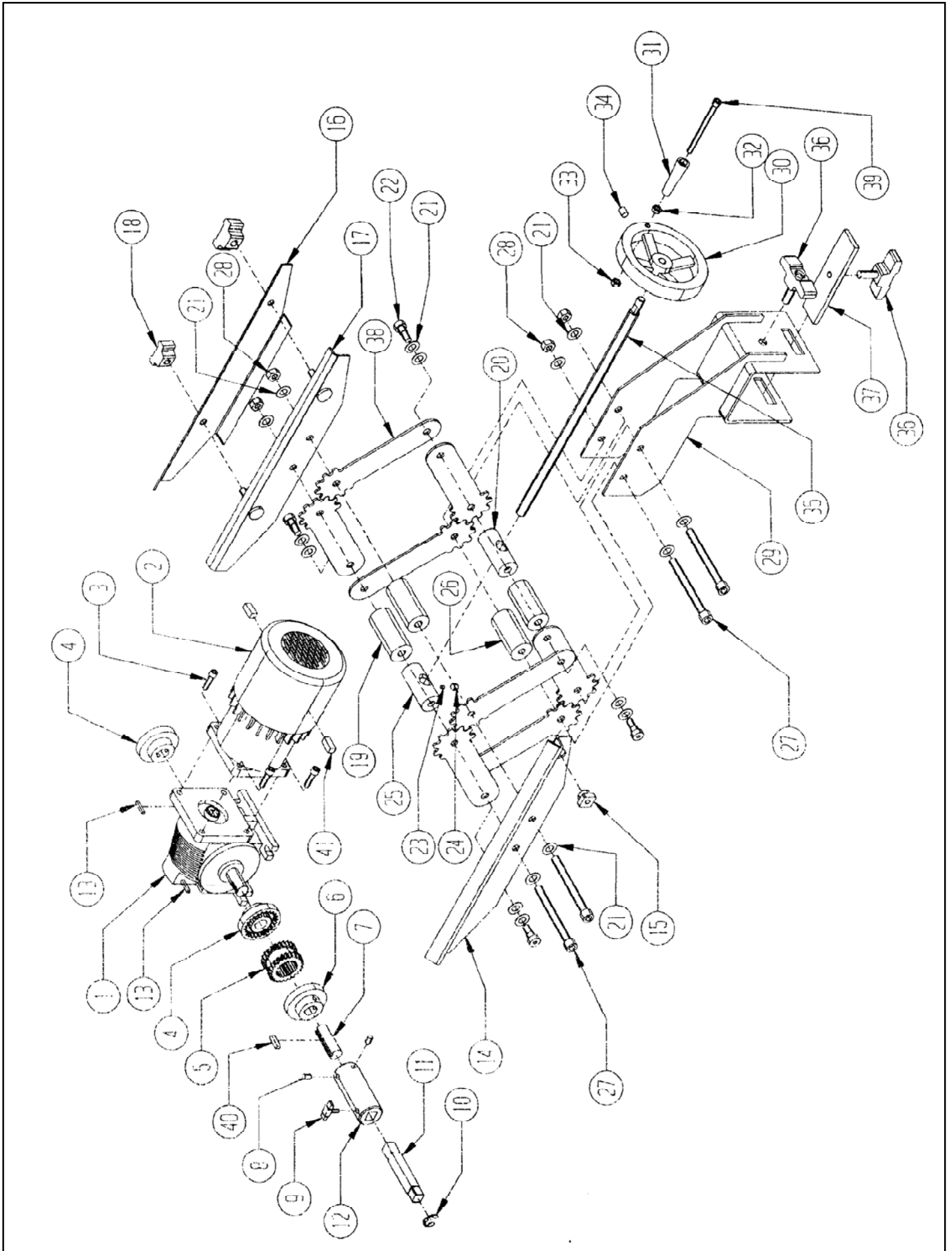

PARTS LIST (Continued)**6509523 SPIN DRIVE ASSEMBLY**

<u>DIAGRAM NUMBER</u>	<u>PART NUMBER</u>	<u>DESCRIPTION</u>
1	3708391	Reducer: 10:1 Ratio
2	6509336	Motor, DC .20 HP TEFC
3	B251411	Socket Head Cap Screw 1/4-20 x 7/8 Long
4	3709586	Flange Coupler .50
5	3709585	Sleeve Coupler
6	3709584	Flange Coupler 5/8
7	6009217	Drive Coupling Adapter
8	C250620	Socket Set Screw 1/4-20 x 3/8
9	6009598	Tee Knob Assembly .50 Long
10	3709073	Retaining Ring
11	6009051	Drive Adapter 1/2 Square
12	6009052	Adapter
13	R000376	Square Key 1/8 x .75 Long
14	6009078	Gearbox Slide Bracket
15	3707279	Strain Relief Wire
16	6009079	Gearbox Clamp Bracket
17	6009580	Gearbox Slide Weldment Bracket
18	3708262	T-Knob - 5/16-18
19	6009045	Linkage Spacer 2.29 Long
20	6009046	Linkage Spacer R.H. Thread
21	3709062	Belleville .75 Dia. x .35 T
22	3709809	Shoulder Bolt .375 Dia. x .375 Long
23	3709705	Nylon Ball 5/32 Dia.
24	C310420	Socket Set Screw 5/16-18 x 1/4
25	6009047	Linkage spacer L. H. Thread
26	6009048	Linkage Spacer 2.5 Long
27	B375611	Socket Head Cap Screw
28	J377100	Nylok Hex Locknut 3/8-16
29	6509519	Support Bracket Weldment
30	3708148	Handwheel 4.5 Dia.
31	3709370	Handle
32	J252000	Hex Jam Nut 1/4-20
33	J257000	1/4-20 Nylok Locknut
34	C310620	Socket Set Screw 5/16-18 x 3/8 Long
35	6009076	Double Thread Rod
36	6009555	Knob Assembly
37	6509114	Spin Drive Plate Lock
38	6009067	Geared Linkage
39	B255011	Socket Head Cap Screw 1/4-20 x 3 1/8 Long
40	R000377	Square Key 3/16 x .75 Long
41	3707623	DC Motor Brush

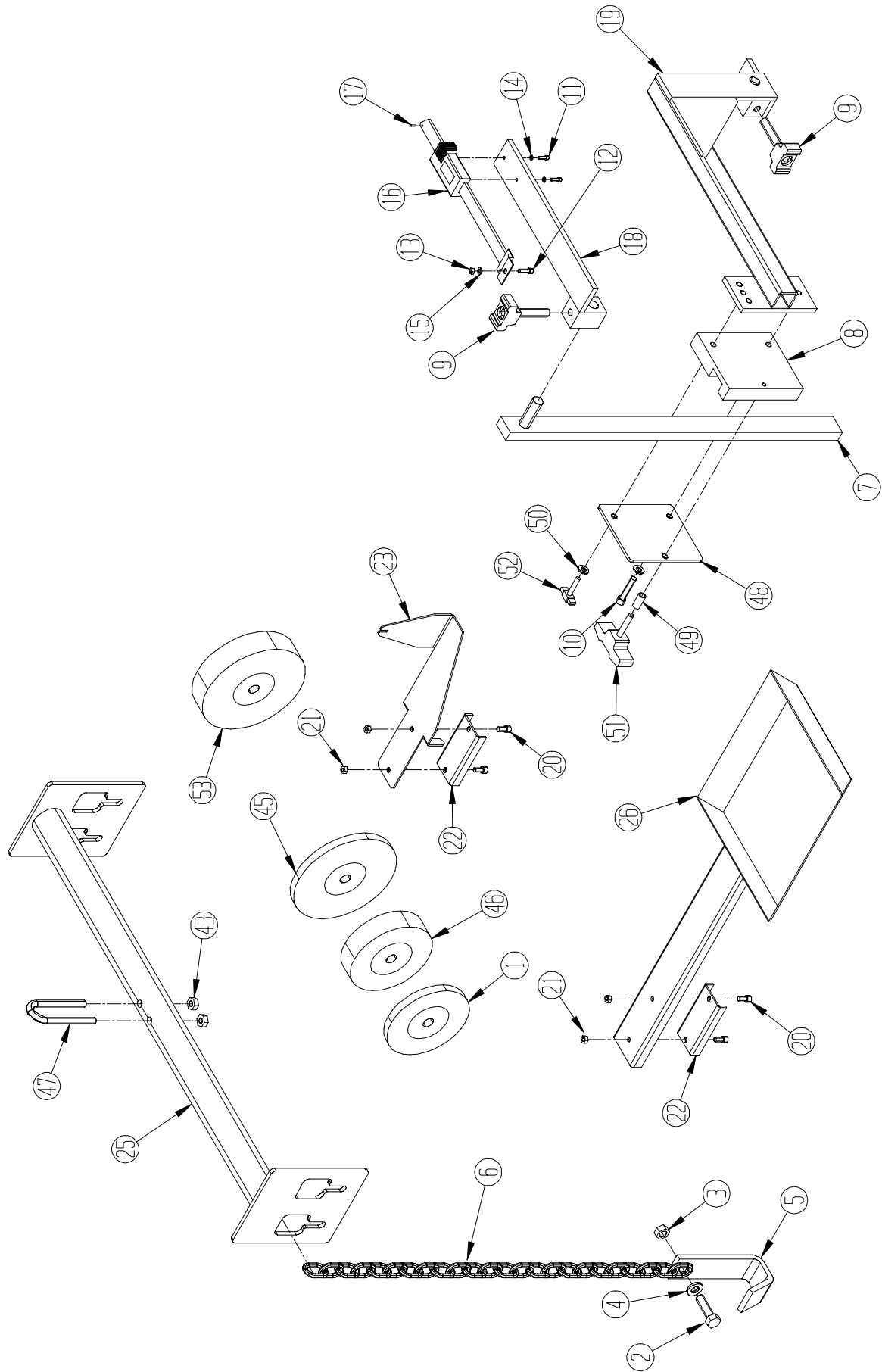

PARTS LIST (Continued)

6309549 MISCELLANEOUS PARTS

<u>DIAGRAM NUMBER</u>	<u>PART NUMBER</u>	<u>DESCRIPTION</u>
1	3700088	Grinding Wheel 3.5" Dia. x .38 w
2	B371601	Hex Head Cap Screw 3/8-16 x 1 Long
3	J377100	Nylok Locknut
4	K370001	3/8 Flat Washer
5	6009102	Grab Hook
6	6509113	Chain
7	6509569	Gage Bar Assembly-Vertical
8	6509418	Plate-Pivot
9	6509567	Knob Assembly
10	B252011	Socket Head Cap Screw 1/4-20 x 1-1/4 Long
11	B120611	Socket Head Cap Screw 5-40 x .38 Long
12	B161011	Socket Head Cap Screw 8-32 x 5/8 Long
13	J161000	8-32 Hex Nut
14	K121501	No. 5 Split Lockwasher
15	K161501	No. 8 Lockwasher
16	6509359	Digital Gage
17	H060302	1/16 x 3/16L Roll Pin
18	6509412	Base Weldment Indicator
19	6509568	Alignment Extension Weldment
20	B190811	Socket Head Cap Screw 10-24 x 1/2
21	J197100	10-24 Nylok Locknut
22	3708384	Magnet
23	6509143	Reel Positioner Gage
25	6509590	Spreader Bar Weldment
26	6509557	Drip Pan Weldment
43	J317100	5/16-18 Lock Nut
45	3700087	Grinding Wheel 5" Dia. x .3/8" Side
46	3700086	Grinding Wheel 3.5" Dia. x 1" Wide
47	3709316	5/16-18 x 3" U-Bolt 1 1/2"
48	6509349	Retaining Plate
49	3529069	Spacer
50	K251501	1/4 Lockwasher
51	6609501	T-Knob Assembly
52	3708813	T-Knob Assembly
53	3700089*	Grinding Wheel 5" Dia. x 1" Wide

* 3700089- Grinding wheel is installed on grinding head when shipped. The other wheels are located in the carton assembly.

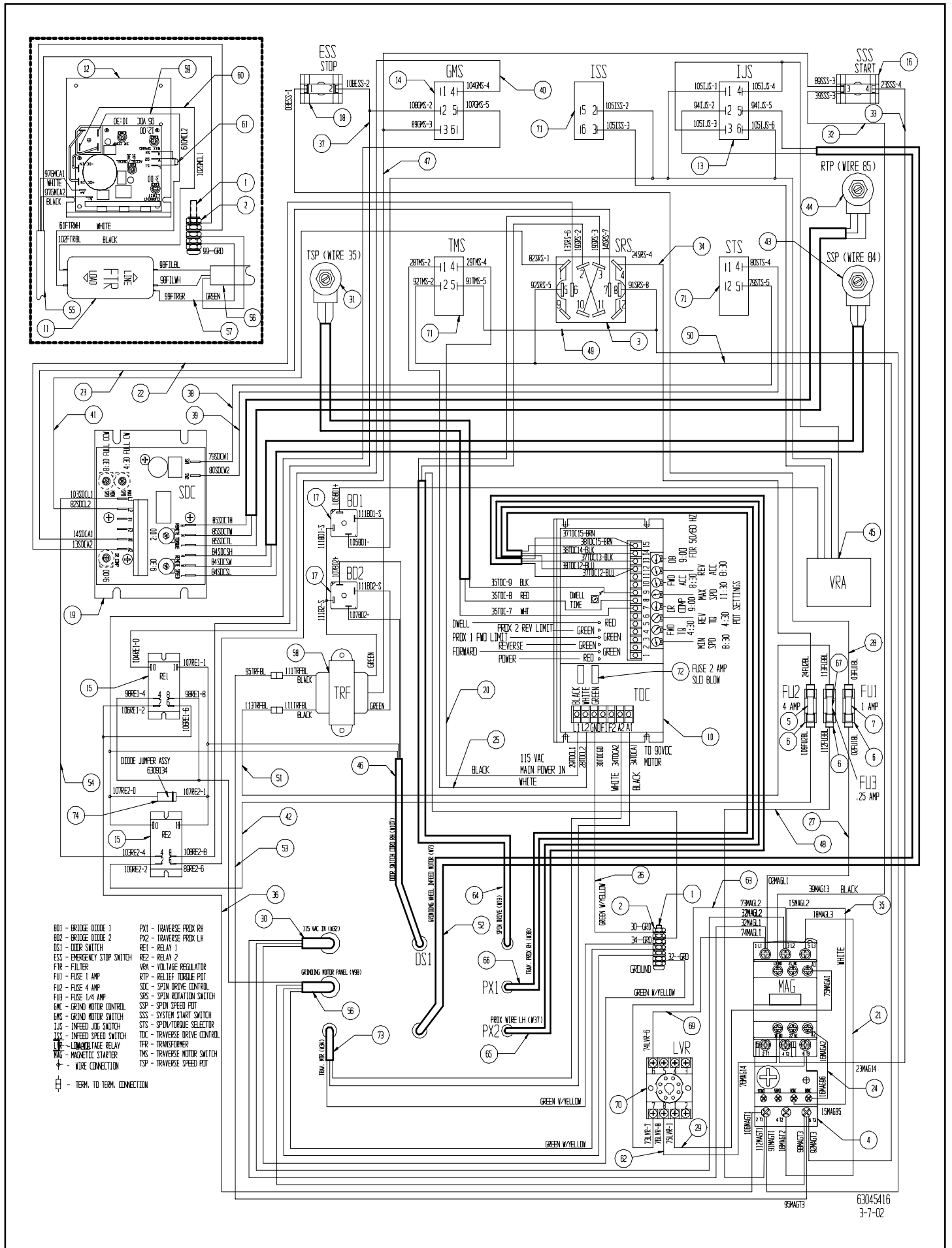

- BD1 - BRIDGE DIODE 1
 - BD2 - BRIDGE DIODE 2
 - DS1 - DOOR SWITCH
 - ESS - EMERGENCY STOP SWITCH
 - FTR - FILTER
 - FU1 - FUSE 1 AMP
 - FU2 - FUSE 4 AMP
 - FU3 - FUSE 1/4 AMP
 - GMC - GROUND MOTOR CONTROL
 - GMS - GROUND MOTOR SWITCH
 - IJS - IN-REED JOBB SWITCH
 - IJS - IN-REED JOBB SWITCH
 - LVR - LOW VOLTAGE RELAY
 - MAG - MAGNETIC STARTER
 - +
 -
 - ⊞ - TERM. TO TERM. CONNECTION
- PX1 - TRAVERSE PROX RH
 - PX2 - TRAVERSE PROX LH
 - RE1 - RELAY 1
 - RE2 - RELAY 2
 - VRA - VOLTAGE REGULATOR
 - RTP - RELIEF TORQUE POT
 - SOC - SPIN DRIVE CONTROL
 - SOS - SPIN ROTATION SWITCH
 - SSP - SPIN SPEED PUT
 - SSS - SYSTEM START SWITCH
 - STS - SPIN/TORQUE SELECTOR
 - TMS - TRAVERSE DRIVE CONTROL
 - TRF - TRANSFORMER
 - TMS - TRAVERSE MOTOR SWITCH
 - TSP - TRAVERSE SPEED PUT

63045416
3-7-02

PARTS LIST (Continued)

<u>DIAGRAM NUMBER</u>	<u>PART NUMBER</u>	<u>DESCRIPTION</u>
1	B192013	Button Head Cap Screw 10-24 x 1.25
2	R000553	Kep 10-24
3	3707080	Toggle Switch Hes/Rev
4a	3707556	Magnetic Starter 1 HP
4b	3707557	Overload Relay for Starter
5	3707090	Slo-Blo Fuse 4 AMP
6	3707091	Fuse Block
7	3707092	Slo-Blo Fuse 1 AMP
8	3707224	Cable Mount Tie
9	3707225	Cable Tie 6.5L x .18W x .052T
10	3707550	Traverse Control Board
11	3707403	Power Line Filter
12	3707425	Control Board Power Motor 1 HP
13	3707428	Rocker Switch MOM On/Off/On
14	3707429	Rocker Switch On/Off
15	3707431	DPST Relay 24VDC Coil
16	See page 69	Pushbutton Start Assembly
17	3707526	Bridge Diode 25 AMP
18	See page 69	Pushbutton Stop Assembly
19	3707524	Spin with Relay Control Board
20	6009104	Wire Assembly .25F/#5FK
21	6009110	Wire Assembly FER/FER
22	6009111	Wire Assembly .25F/.25F
23	6009112	Wire Assembly .25F/.25F
24	6009113	Wire Assembly #6FK/#6FK
25	6009117	Wire Assembly .25F/#6FK
26	6009118	Wire Assembly #6FK/#10RG
27	6009180	Wire Assembly .25F/#6FK
28	6009181	Wire Assembly .25F/#6FK
29	6709112	Wire Assembly STR/FK W75
30	6009196	Main Power Cord
31	6009199	Traverse Pot Assembly
32	6009201	Wire Assembly #6FK/#6FK
33	6009202	Wire Assembly #6FK/#6FK
34	6009203	Wire Assembly .25F/.25F
35	6009204	Wire Assembly #6FK/#6FK
36	6309106	Wire Assembly 2-Loop

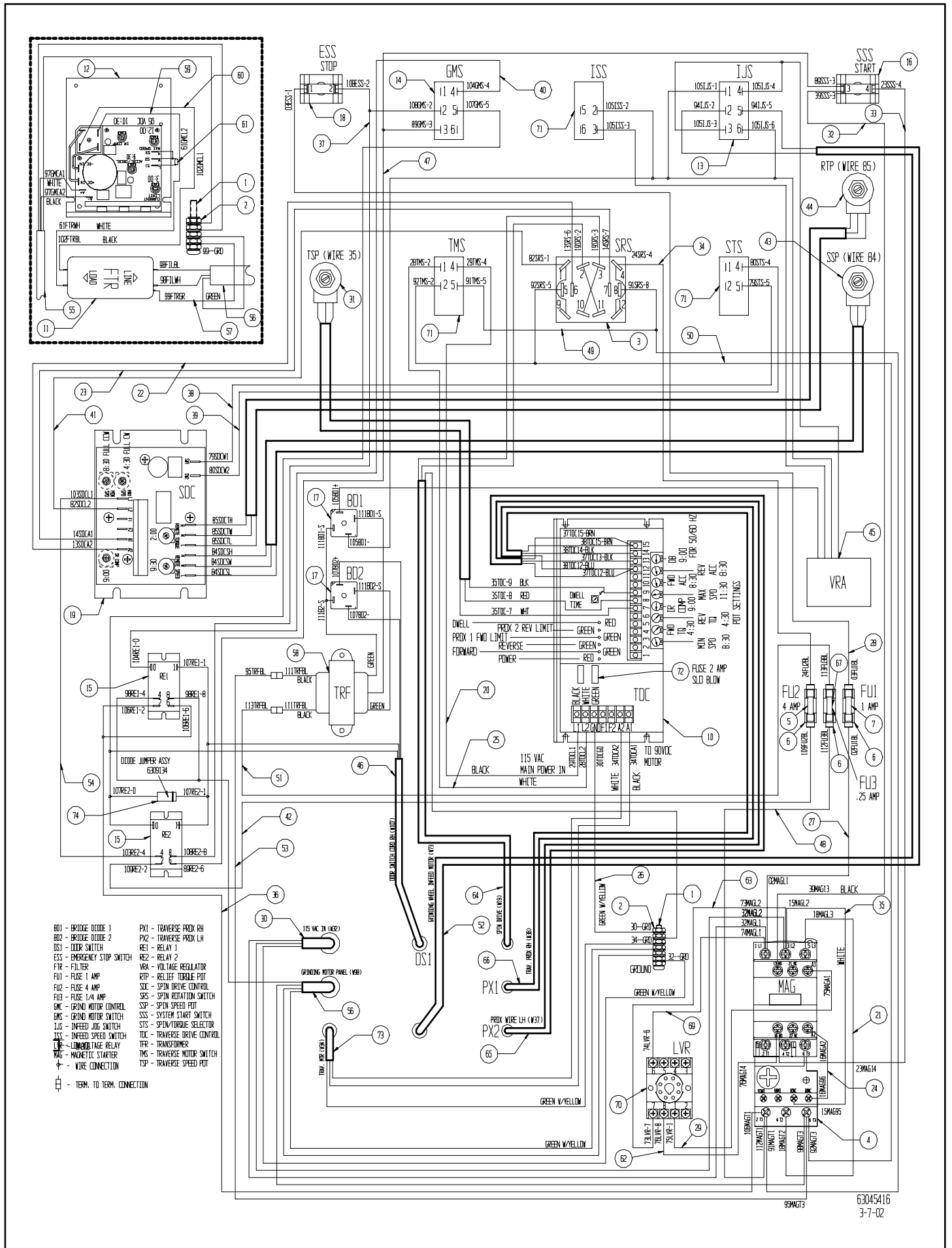

- BD1 - BRIDGE DIODE 1
- BD2 - BRIDGE DIODE 2
- DS1 - DOOR SWITCH
- ESS - EMERGENCY STOP SWITCH
- FTR - FILTER
- FU1 - FUSE 1 AMP
- FU2 - FUSE 4 AMP
- FU3 - FUSE 1/4 AMP
- GMC - GROUND MOTOR CONTROL
- GMS - GROUND MOTOR SWITCH
- IJS - INFEED JOG SWITCH
- IJS - INFEED JOG SWITCH
- LVR - LOW VOLTAGE RELAY
- MAG - MAGNETIC STARTER
- +
-
- WIRE CONNECTION
- TERM. TO TERM. CONNECTION
- PX1 - TRAVERSE PROX RH
- PX2 - TRAVERSE PROX LH
- RE1 - RELAY 1
- RE2 - RELAY 2
- VRA - VOLTAGE REGULATOR
- RTP - RELIEF TORQUE POT
- SOC - SPIN DRIVE CONTROL
- SOS - SPIN ROTATION SWITCH
- SSP - SPIN SPEED POT
- SSS - SYSTEM START SWITCH
- STS - SPIN/TORQUE SELECTOR
- TMS - TRAVERSE DRIVE CONTROL
- TRF - TRANSFORMER
- TMS - TRAVERSE MOTOR SWITCH
- TSP - TRAVERSE SPEED POT

PARTS LIST (Continued)

<u>DIAGRAM NUMBER</u>	<u>PART NUMBER</u>	<u>DESCRIPTION</u>
37	6309108	Wire Assembly 2-Loop
38	6309060	Wire Assembly .25F/.25F
39	6309061	Wire Assembly .25F/.25FK
40	6309104	Wire Assembly .25F/.25F
41	6309063	Wire Assembly .25F/.25F
42	6309109	Wire Assembly .25F/.25F
43	6309065	Spin (SSP) Pot Assembly
44	6309066	Relay Torque Pot Assembly
45	6309105	Voltage Regulator Assembly
46	6309107	Door Safety Switch Assembly
47	6309069	Wire Assembly 2-Loop
48	6309121	Wire Assembly .25F/Fer
49	6309071	Wire Assembly 2-Loop
50	6309072	Wire Assembly 2-Loop
51	6309122	Wire Assembly .25M/.25F
52	6309074	Infeed Motor Cord
53	6309075	Wire Assembly .25M/#6FK
54	6309103	Wire Assembly .25F/.25F
55	6309077	Grinding Motor Cord
56	6309123	Motor BRD Power Cord
57	6309079	Wire Assembly .25F/RG
58	6309511	Transformer Assembly
59	6509301	Wire Assembly .25F x 2
60	6509302	Wire Assembly .25F x 2
61	6504596	Resistor/Jumper Assembly
62	6709113	Wire Assembly .25F x 2
63	6709110	Wire Assembly Str/FK W73
64	6509336	Spin Motor Assembly
65	6309056	Left-Hand Traverse Proximity
66	6309057	Right-Hand Traverse Proximity
67	3707586	Slow-Blo Fuse 1/4 Amp
69	6709111	Wire Assembly Str/FK W74
70	3707073	8 Pin Socket
71	3707367	Rocker Switch On/Off
72	3707546	Slo-Blo Fuse 3 AMP
73	6309084	Traverse Motor Cord
74	6309134	Diode Jumper Assembly

WIRING SCHEMATIC

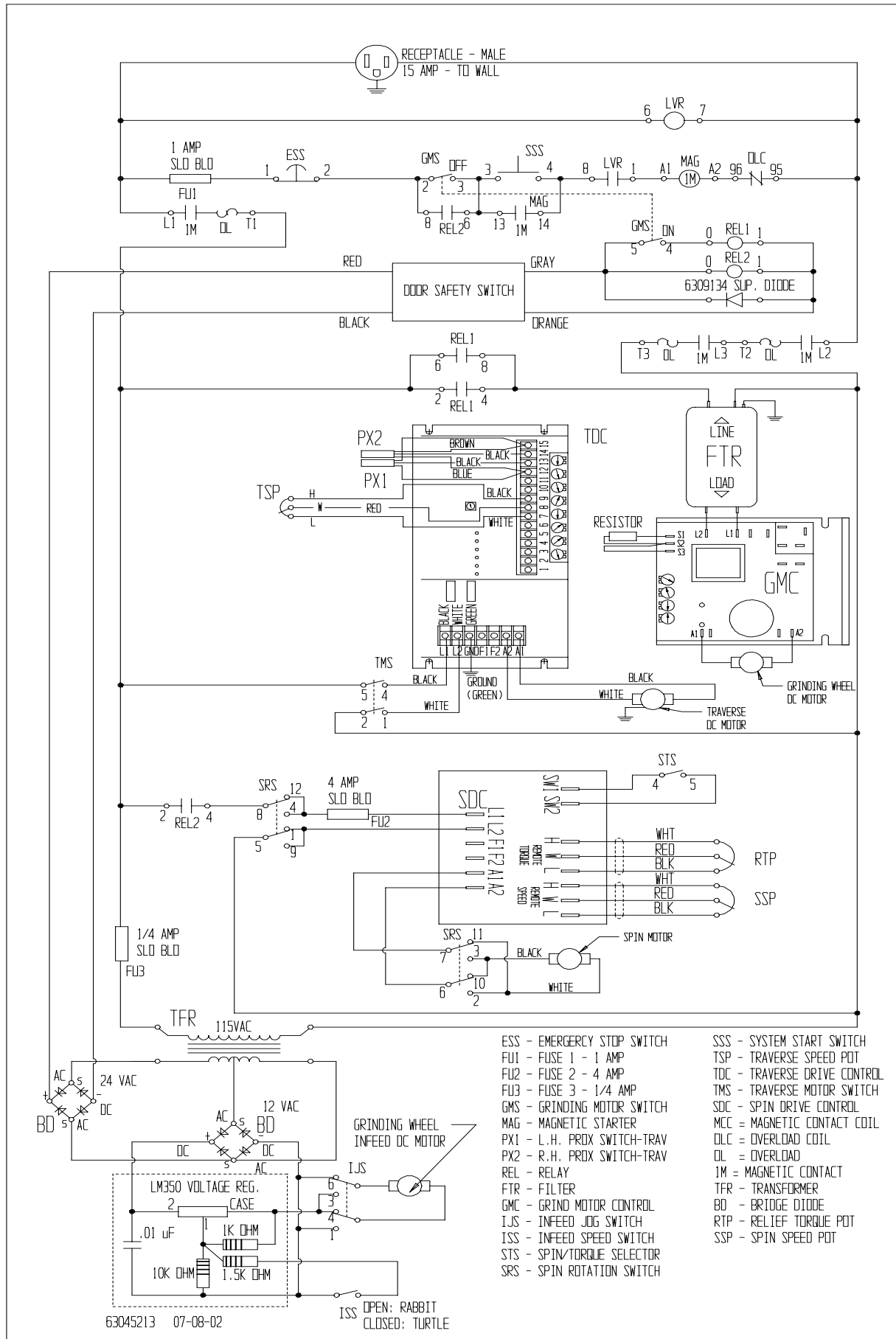

This page was left intentionally blank for note-taking purposes