



*Setting the Standard With the
World's Most Valued Grinders.*

ACCU-PRO 630 SPIN RELIEF GRINDER

This book consists of two manuals:

The OPERATORS MANUAL which contains all the information on operating and doing routine daily maintenance on this equipment.

The ASSEMBLY and SERVICE MANUAL which is used by the maintenance department to install the equipment and to do all maintenance except routine daily maintenance.

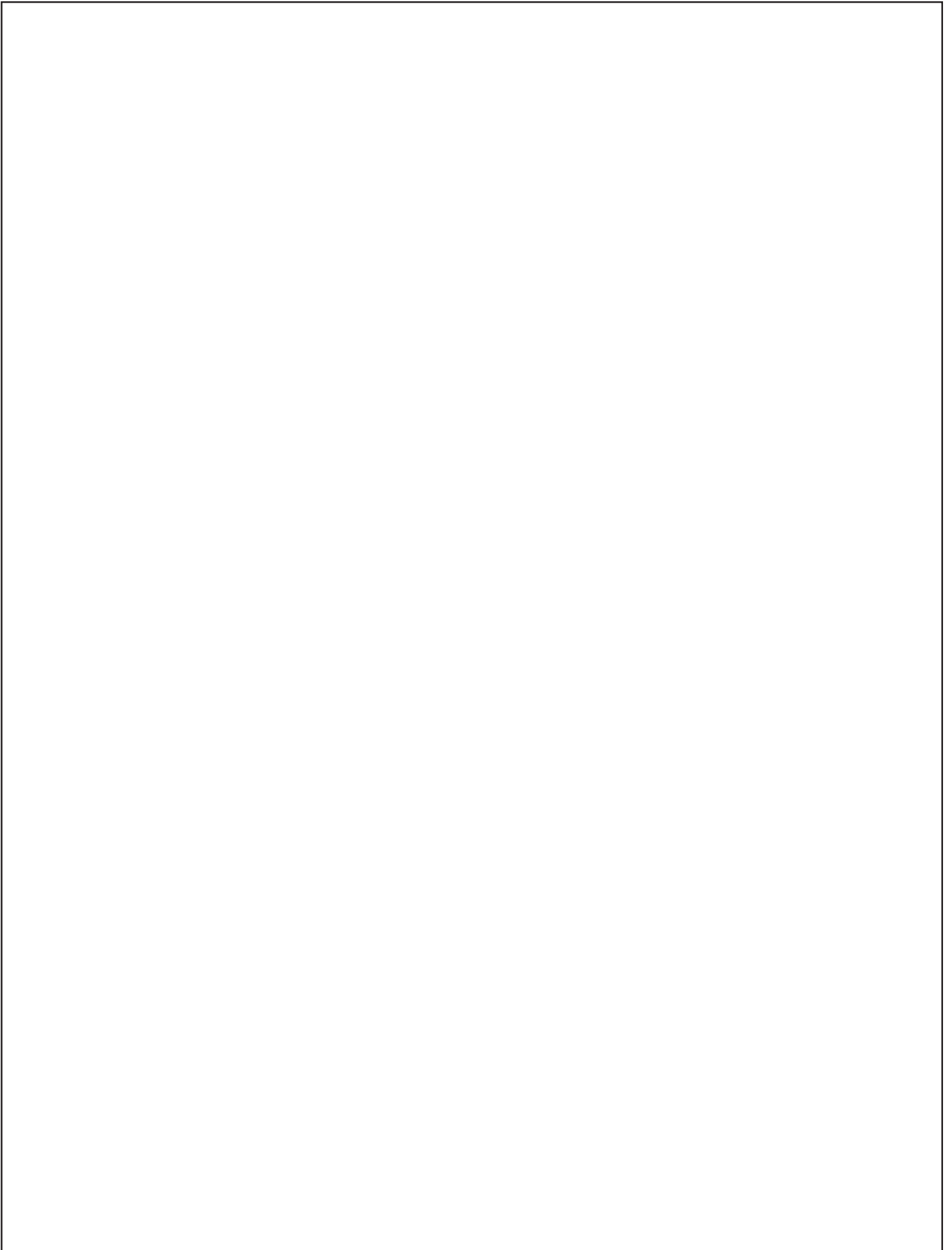

ACCU-PRO 630 **SPIN RELIEF** **GRINDER**

OPERATORS **MANUAL**



WARNING

You must thoroughly read and understand this manual before operating the equipment, paying particular attention to the Warning & Safety instructions.

SAFETY INSTRUCTIONS



Safety Awareness Symbols are inserted into this manual to alert you to possible **Safety Hazards**. Whenever you see these symbols, follow their instructions.

The **Warning Symbol** identifies special instructions or procedures which, if not correctly followed, could result in personal injury.

The **Caution Symbol** identifies special instructions or procedures which, if not strictly observed, could result in damage to or destruction of equipment.

1. **KEEP GUARDS IN PLACE** and in working order.
2. **REMOVE WRENCHES AND OTHER TOOLS.**
3. **KEEP WORK AREA CLEAN.**
4. **DON'T USE IN DANGEROUS ENVIRONMENT.** Don't use Grinder in damp or wet locations. Machine is for indoor use only. Keep work area well lit.
5. **KEEP ALL VISITORS AWAY.** All visitors should be kept a safe distance from work area.
6. **MAKE WORK AREA CHILD-PROOF** with padlocks or master switches.
7. **DON'T FORCE THE GRINDER.** It will do the job better and safer if used as specified in this manual.
8. **USE THE RIGHT TOOL.** Don't force the grinder or an attachment to do a job for which it was not designed.
9. **WEAR PROPER APPAREL.** Wear no loose clothing, gloves, neckties, or jewelry which may get caught in moving parts. Nonslip footwear is recommended. Wear protective hair covering to contain long hair.
10. **ALWAYS USE SAFETY GLASSES.**
11. **SECURE YOUR WORK.** Make certain that the cutting unit is securely fastened with the clamps provided before operating.
12. **DON'T OVERREACH.** Keep proper footing and balance at all times.
13. **MAINTAIN GRINDER WITH CARE.** Follow instructions in Service Manual for lubrication and preventive maintenance.
14. **DISCONNECT POWER BEFORE SERVICING,** or when changing the grinding wheel.
15. **REDUCE THE RISK OF UNINTENTIONAL STARTING.** Make sure the switch is **OFF** before plugging in the grinder.
16. **USE RECOMMENDED ACCESSORIES.** Consult the manual for recommended accessories. Using improper accessories may cause risk of personal injury.
17. **CHECK DAMAGED PARTS.** A guard or other part that is damaged or will not perform its intended function should be properly repaired or replaced.
18. **KNOW YOUR EQUIPMENT.** Read this manual carefully. Learn its application and limitations as well as specific potential hazards.
19. **KEEP ALL SAFETY DECALS CLEAN AND LEGIBLE.** If safety decals become damaged or illegible for any reason, replace immediately. Refer to replacement parts illustrations in Service Manual for the proper location and part numbers of safety decals.
20. **DO NOT OPERATE THE GRINDER WHEN UNDER THE INFLUENCE OF DRUGS, ALCOHOL, OR MEDICATION.**

SAFETY INSTRUCTIONS



IMPROPER USE OF GRINDING WHEEL MAY CAUSE BREAKAGE AND SERIOUS INJURY.



Grinding is a safe operation if the few basic rules listed below are followed. These rules are based on material contained in the ANSI B7.1 Safety Code for "Use, Care and Protection of Abrasive Wheels". For your safety, we suggest you benefit from the experience of others and follow these rules.

DO

1. **DO** always **HANDLE AND STORE** wheels in a careful manner.
2. **DO VISUALLY INSPECT** all wheels before mounting for possible damage.
3. **DO CHECK MACHINE SPEED** against the established maximum safe operating speed marked on wheel.
4. **DO CHECK MOUNTING FLANGES** for equal and correct diameter.
5. **DO USE MOUNTING BLOTTERS** when supplied with wheels.
6. **DO** be sure **WORK REST** is properly adjusted.
7. **DO** always **USE A SAFETY GUARD COVERING** at least one-half of the grinding wheel.
8. **DO** allow **NEWLY MOUNTED WHEELS** to run at operating speed, with guard in place, for at least one minute before grinding.
9. **DO** always **WEAR SAFETY GLASSES** or some type of eye protection when grinding.

DON'T

1. **DON'T** use a cracked wheel or one that **HAS BEEN DROPPED** or has become damaged.
2. **DON'T FORCE** a wheel onto the machine **OR ALTER** the size of the mounting hole--if wheel won't fit the machine, get one that will.
3. **DON'T** ever **EXCEED MAXIMUM OPERATING SPEED** established for the wheel.
4. **DON'T** use mounting flanges on which the bearing surfaces **ARE NOT CLEAN, FLAT AND FREE OF BURRS.**
5. **DON'T TIGHTEN** the mounting nut **EXCESSIVELY.**
6. **DON'T** grind on the **SIDE OF THE WHEEL** (see Safety Code B7.2 for exception).
7. **DON'T** start the machine until the **WHEEL GUARD IS IN PLACE.**
8. **DON'T JAM** work into the wheel.
9. **DON'T STAND DIRECTLY IN FRONT** of a grinding wheel whenever a grinder is started.
10. **DON'T FORCE GRINDING** so that motor slows noticeably or work gets hot.



AVOID INHALATION OF DUST generated by grinding and cutting operations. Exposure to dust may cause respiratory ailments. Use approved NIOSH or MSHA respirators, safety glasses or face shields, and protective clothing. Provide adequate ventilation to eliminate dust, or to maintain dust level below the Threshold Limit Value for nuisance dust as classified by OSHA.



Setting the Standard With the World's Most Valued Grinders.

We are committed to:

Providing superior customer support, training, and service.

Manufacturing the highest quality products at an unequaled value.

Setting the industry standard by investing in technological product innovation.

Manufacturing products specifically designed to maintain original equipment manufacturers' specifications.

Interacting with and supporting all original equipment manufacturers.

TABLE OF CONTENTS

This machine is intended for grinding the reel of reel type mower units ONLY. Any use other than this may cause personal injury and void the warranty.



To assure the quality and safety of your machine and to maintain the warranty, you **MUST** use original equipment manufactures replacement parts and have any repair work done by a qualified professional.

ALL operators of this equipment must be thoroughly trained BEFORE operating the equipment.

Do not use compressed air to clean grinding dust from the machine. This dust can cause personal injury as well as damage to the grinder. Machine is for indoor use only. Do not use a power washer to clean the machine.



Low Voltage Relay

The grinder is equipped with a low voltage relay which is factory preset at 100 VAC. If the power supply line does not deliver 100 VAC power under load, the relay will open and trip out the starter. If this occurs, your power supply line is inadequate and must be correct before proceeding further with the grinder.

CONTENTS

Safety Warnings	Page 4-6
Daily Maintenance	Page 6
Getting to Know Your Grinder	Page 7-14
Safety Warnings	Page 15-17
Operating Instructions	Page 18-31
Reel Setup Chart.....	Page 33

DAILY MAINTENANCE BY THE OPERATOR

On a daily basis, clean the machine by wiping it off.

On a daily basis, remove all grinding grit from the grinding head and bellows area.

On a daily basis, inspect the machine for loose fasteners or components.

Contact your company's Maintenance Department if damaged or defective parts are found.



DO NOT USE COMPRESSED AIR TO CLEAN GRINDING DUST FROM GRINDER

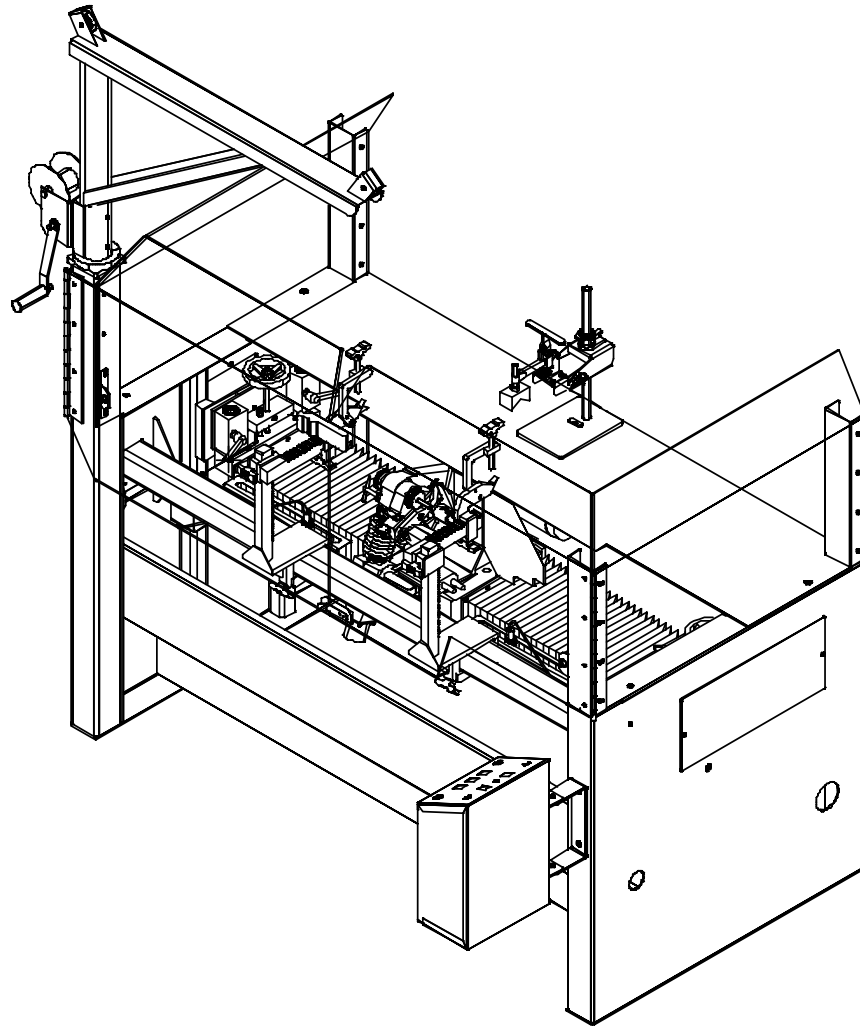

SPECIFICATIONS

Traversing Switches	Solid state, non-contacting proximity switches.
Carriage Travel	38" [97 cm]
Overall Width	71" [181 cm]
Overall Height	85" [220 cm]
Overall Depth	38" [155 cm]
Weight	1240 lbs. [1045kg] 1400 lbs shipping weight [1140 kg]
Base Construction	Precision heavy duty reinforced welded steel base
Carriage Rails	Precision Ground, Hardened Steel - 1.000 Dia. [25.4 mm]
Grind Head Motor	1HP DC Motor, 4300 RPM
Winch Capacity	400 lbs. maximum [180 kg]
Spin Motor	.20 HP Fan Cooled Variable Speed DC Motor
Sound Level	More than 75 Dba, Less than 95 Dba
Auto Traverse	Ball bearing threadless roller drive with built-in overload protection
Rail Covers	Telescoping bellows
Control System	<ul style="list-style-type: none"> *Safety power and main door interrupt switches *Reversible Spin drive for variable speed Spin or variable torque Relief Functions *Solid State grinding motor control and variable speed traverse control.

GETTING TO KNOW YOUR GRINDER (Continued)

CONTROL PANEL COMPONENT IDENTIFICATION

Review the following control panel component descriptions before proceeding with the instructions

SYSTEM START SWITCH

Powers all control panel systems.
Pulls in the main magnetic starter.

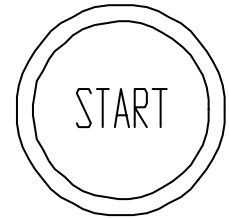

GRIND SELECTOR SWITCH

Variable speed spin

Switch must be up to perform spin grinding operations.

Variable Torque Relief

Switch must be down to perform relief grinding operations.

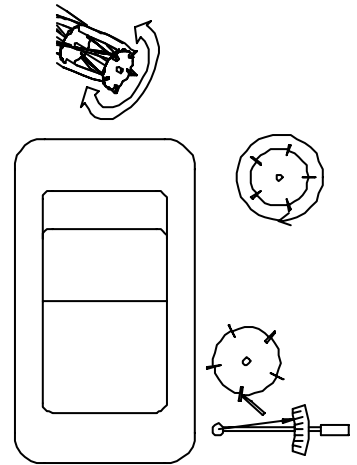

SPIN DRIVE ROTATION SWITCH

Forward / Off / Reverse

This switch reverses the spin drive motor. Toggle in middle is off position and stops rotation.

NOTE : Because the spin drive motor can mount on either side of the reel rotation direction will vary.

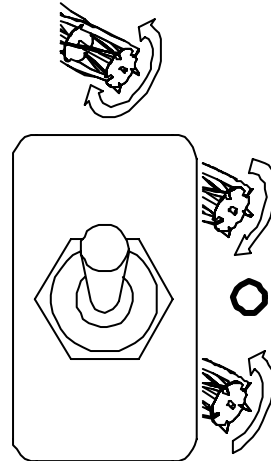

SPIN SPEED DIAL

RPM

Adjusts the speed of reel rotation when you have the grind selector switch set at variable speed spin.

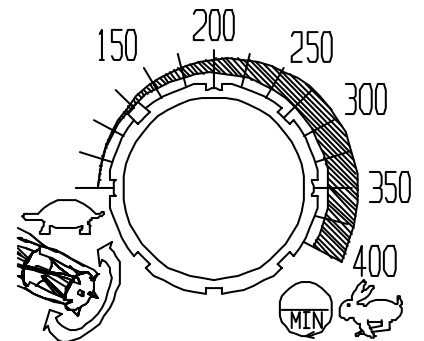

GETTING TO KNOW YOUR GRINDER (Continued)

RELIEF TORQUE DIAL

Adjusts the Spin Drive Motor torque (the torque holding the reel blade to the relief finger) when Grind Selector Switch is set at variable Torque Relief.

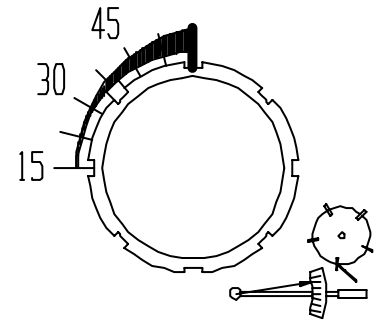

GRINDING WHEEL MOTOR SWITCH On / Off

Turn the Grinding Wheel Motor on and off. Guard doors must be shut for Grinding Motor to operate.

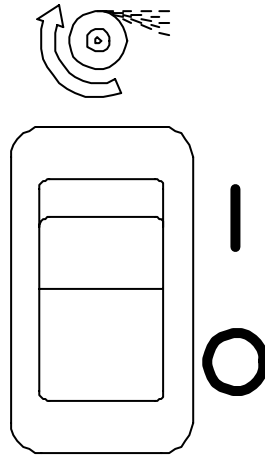

INFEEED JOG SELECTOR Slow / Fast

Switch up is fast infeed speed & switch down is slow infeed speed.

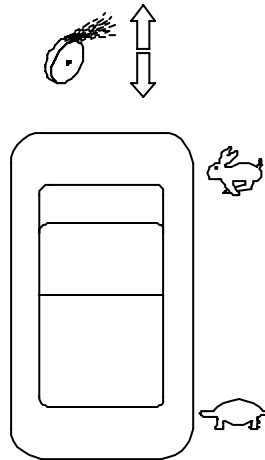

INFEEED JOG SELECTOR Up / Down

Moves the Grinding Wheel up or down.

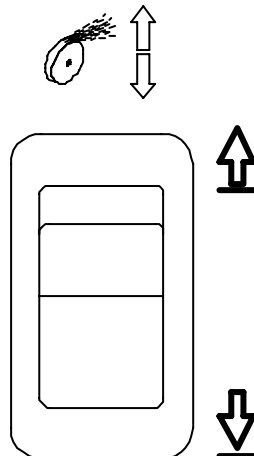

GETTING TO KNOW YOUR GRINDER (Continued)

TRAVERSE MOTOR SWITCH

Turns the traverse drive motor ON/OFF.

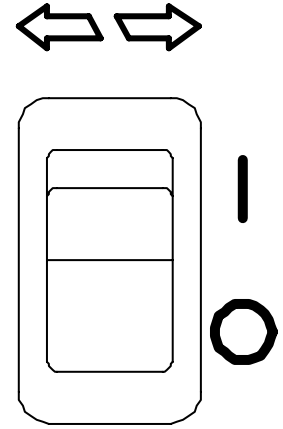

TRAVERSE SPEED DIAL - FT / MIN

Adjusts the speed of the left & right movement of the Grinding wheel (Carriage).

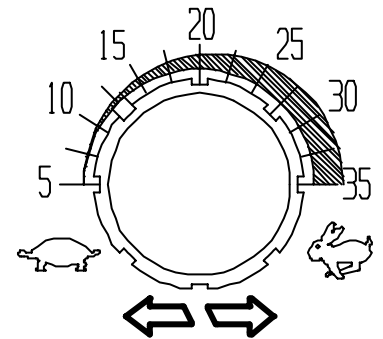

EMERGENCY STOP BUTTON

Cuts all power to the control panel functions. Stops all motors, including grinding motor, traverse motor, infeed stepper motor, etc.



PUSHING THE EMERGENCY STOP BUTTON DOES NOT STOP ALL POWER TO THE GRINDER. POWER IS STILL DELIVERED TO THE INFEEED SIDE OF THE MAGNETIC CONTACTOR. DISCONNECT THE CORD AT THE WALL OUTLET BEFORE PERFORMING SERVICE.

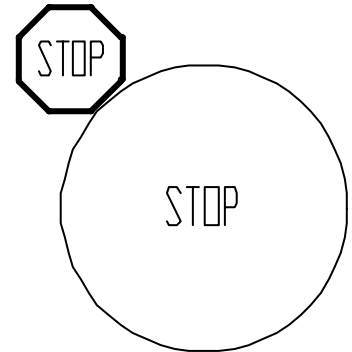

GETTING TO KNOW YOUR GRINDER (Continued)

FRONT AND REAR MOWER MOUNTING

The mowing unit is placed into the machine with the rear roller on the table and front roller held with the front tooling clamps. The front tooling bar clamps can be moved from side to side along the tooling so they can be positioned as far apart as possible on varying widths of reels (loosen knob on lower part of bar mounting bracket in FIG. 1). You also have the ability to adjust the height (loosen knob on horizontal bracket in FIG. 10) and the forward and backward position (loosen knob on roller clamp bracket in FIG. 1). This allows the mower unit to be set up with the bottom of the reel approximately flush to the table and the center of the reel aligned to the reel positioner gage (see section on reel positioner gage below). When the front tooling clamps and mower unit are in proper position lock in place by tightening knobs. The rear roller clamp is positioned with the V-clamp block centered on the rear roller. The height of the rear roller clamp can be adjusted down by simply pushing the unit down and adjusting up by first pulling up on the pony leafs and then sliding the unit up. To lock the front tooling clamps rotate the roller clamp up and lock in place with the quick release pin. Then turn the t-knobs clockwise until roller is firmly held in place. See FIG. 1.

REEL POSITIONER GAGE

The Reel Positioner Gage is used to obtain proper in and out (fore and aft) positioning of the mower unit. Mount the Reel Positioner Gage onto the table with the ears butted against gaging surface of the table. See FIG. 2.

You then position the center of the reel within the slot in the Positioner Gage. This is an approximate starting point for setup purposes. There are special reels and unique situations that may require the reel to not be set on the center of the flag. This flag is for setup reference only.

TRAVERSE ACTUATOR RELEASE

The actuator that drives the grinding carriage left and right can be released to allow manual movement of the grinding carriage. The actuator release arm is located at the front of the carriage under the Carriage Proximity Flag Bracket. See FIG. 3 Rotate the release arm clockwise approximately 1/2 turn to release actuator and counter clockwise approximately 1/2 turn to engage actuator.

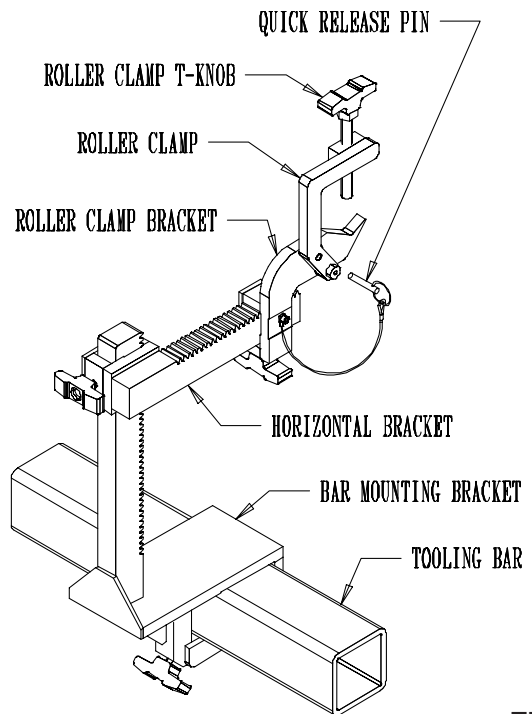

FIG. 1

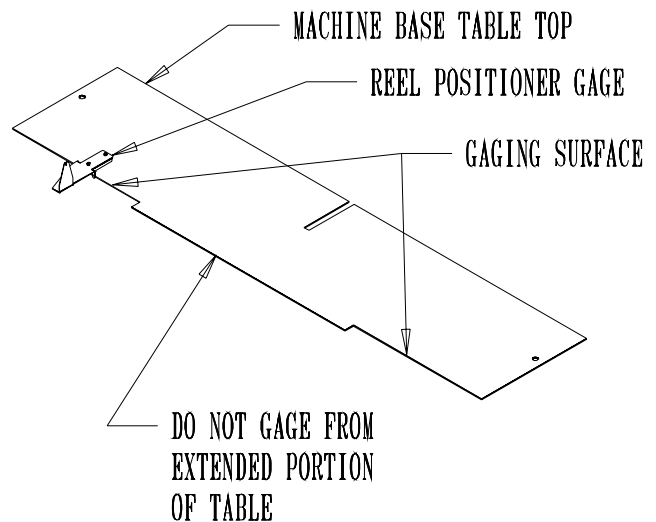

FIG. 2

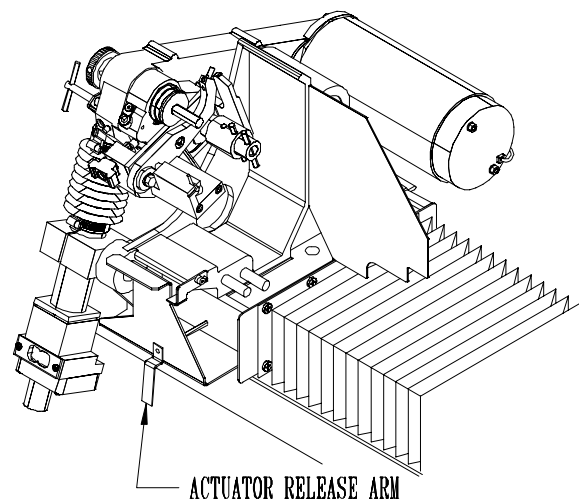

FIG. 3

GETTING TO KNOW YOUR GRINDER (Continued)

TRAVERSE PROXIMITY SENSORS

The Traverse Proximity Sensors are used to change the traversing directions for the grinding carriage and are mounted in the Proximity Brackets located in front of the Traverse Base. See FIG. 4. The sensors are mounted with wave washers to allow a left and right sliding movement without loosening the sensor nuts. There is a red light on the sensor which lights up when the switch is activated.

GRINDING HEAD POSITIONS SPIN/RELIEF

The Finger and Body Assembly of the grinding head rotates on the Grinding Head Housing to change positions between spin grinding and relief grinding. To change the position of the finger and Body Assembly you have to pull out the Plunger Pin on the left side of the Grinding Head Housing. See FIG. 5. When you are going to perform spin grinding operations the Finger and Body Assembly must be rotated clockwise (looking at it from the right). This rotates the fingers out of the reel blade path. See FIG. 5. When you are going to perform relief grinding operations the Finger and Body Assembly must be rotated counter clockwise. This rotates the finger into position to touch and control the reel blades. See FIG. 6

INDEX FINGER ADJUSTMENTS

The Finger and Body Assembly includes two fingers. See FIG. 5. The Fixed Relief Finger is equivalent to the Relief Fingers on other relief grinders. When relief grinding the Movable Index Stop Finger moves from the Relief Finger Side (back side) of the reel blade when traversing from right to left to the grinding wheel side (front side) of the reel blade when traversing from left to right. This feature allows the fully Automatic Relief function. When performing relief grinding operations it is important to have the Index Stop Finger adjusted properly.

STEP 1: Once you have the Grinding Head positioned with a reel blade resting on the Fixed Relief Finger high point, you want about 1/32" [.8mm) to 1/16" [1.5mm) free play of the Index Finger behind the reel blade. The Index Finger is spring loaded to the up position. To check free play, push down on the Index Finger. See FIG. 6. To make this adjustment you have to first turn the Index Lock Handle counter clockwise to unlock the adjustable Index Lever. See FIG. 6. If there is no free play of the Index Finger you want to rotate the Adjustable Index Lever clockwise. If there is more than 1/16" [1.5 mm) free play you want to rotate the Adjustable Index Lever counterclockwise. When the Index Finger is in proper position rotate the Index Lock Handle clockwise to lock the Adjustable Index Lever.

The Index Stop Pin is height adjustable. It should be adjusted to catch the reel blade and still leave enough clearance to the reel spider after the relief is ground to the reel spider after the relief is ground to the depth required.

NOTE: the reason for the 1/32" (1 mm) clearance is so that the high point of the Relief Finger is acting as the guide during the relief grind cycle. The Index Stop Finger acts as a guide onto the tapered ramp of the Relief Finger.

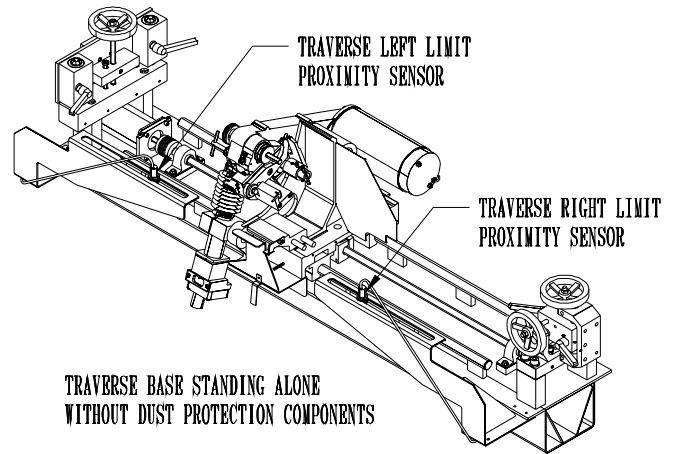

FIG. 4

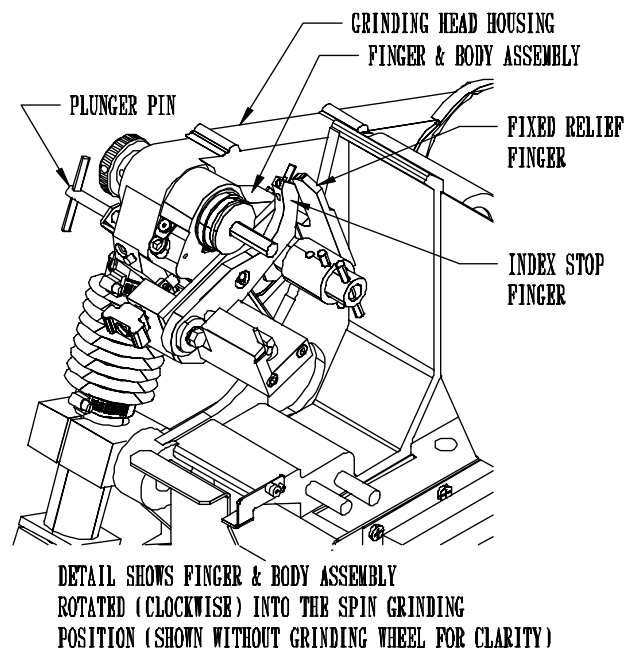

FIG. 5

GETTING TO KNOW YOUR GRINDER (Continued)

STEP 2: With the down limit of the Index Finger properly set you may have to adjust the up limit of the Index Finger for 5" (127 mm) diameter reels with reverse helix blades.

The up travel limit is restricted to keep the Index Finger in the reel blade index path. This is done to properly catch the next blade when indexing or to allow clearance between the back side of the Index Finger and the front side of the blade when the grinding carriage is making its return trip to the home position. If the Index Finger has problems catching the next blade turn the Index Finger T-knob counterclockwise. If there isn't enough clearance between the back side of the Index Finger and the front side of the reel blade turn the Index Finger T-Knob clockwise. See FIG. 6. Adjust the T-knob in by 1/8" (3mm) into the hole opening so the up travel is restricted. Check the up and down swing of the Index Finger for clearance on both sides of the reel blade for the relief grind.

NOTE: This adjustment is factory set for maximum up travel of the index finger for 1/4" (6mm) reel blade thickness. This adjustment should only be needed for small diameter reels, such as 5" [127 mm] diameter reels with reverse helix blades. This adjustment is functional only on cutting units with thin blades on small reels.

ALIGNMENT GAGE

A properly ground reel should be cylindrical. All taper must be ground out of the reel. To ensure the reel will be ground correctly it **MUST** be aligned precisely prior to grinding. The digital alignment gage is used for accurate reel setup. The same gage is used for setting both the horizontal and vertical alignment within thousands of an inch. The digital gage allows you to measure one end of the reel by extending the slide rail until you make contact with the center hub of the reel. See FIG. 7. See FIG. 7. You then reset the gage to zero, retract the slide rail and measure the other end of the reel. The reading on the digital scale tells you exactly how far out of alignment you are. **NOTE:** Gage can be set for both inch and metric readout.

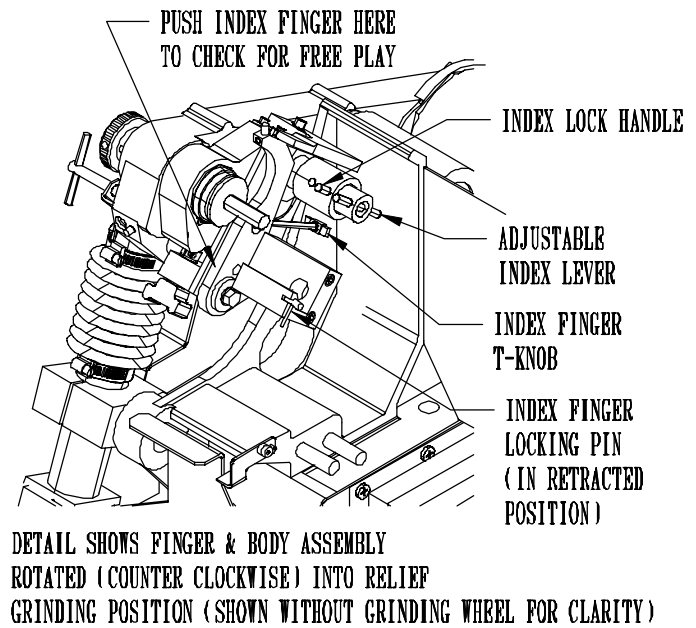

FIG. 6

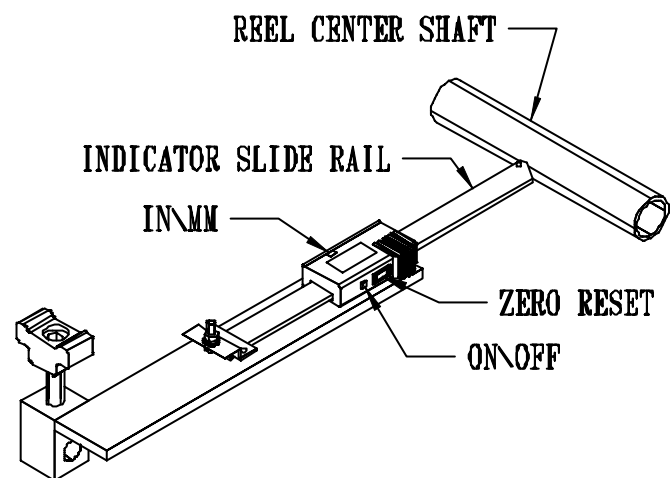

FIG. 7

GETTING TO KNOW YOUR GRINDER (Continued)

RELIEF ANGLE ADJUSTMENT

You should always make sure the Reel Positioner Adjuster is at its mid point before you set up a reel to grind. This will allow to adjust the relief angle by approximately 8 degrees in both directions. You can find the mid point by turning the Reel Positioner Adjuster clockwise, using the 5/16" Allen Key included, until it makes contact with the stop pin (make sure Adjuster is turned completely counter clockwise before you start). Then turn the Reel Positioner Adjuster counterclockwise again 1/2 the number of revolutions you counted. See FIG. 9.

As an example, if the angle you obtain from initial set up is 30 degrees, you can increase the angle as far as approximately 38 degrees by rotating the Reel Positioner Adjuster clockwise until it makes contact with the stop pin. (NOTE: If 38 degrees is not enough relief angle you can move the reel forward one notch on the front tooling horizontal bracket. Make sure you reset the Reel Positioner Adjuster to the mid point again before you move the reel, and always realign reel if it is moved. You can decrease the angle as far as approximately 22 degrees by rotating the Reel Positioner Adjuster counter clockwise until it makes contact with the stop plate. (NOTE: If 22 degrees is still too much relief angle, you can move the reel back one notch on the front tooling horizontal bracket.)

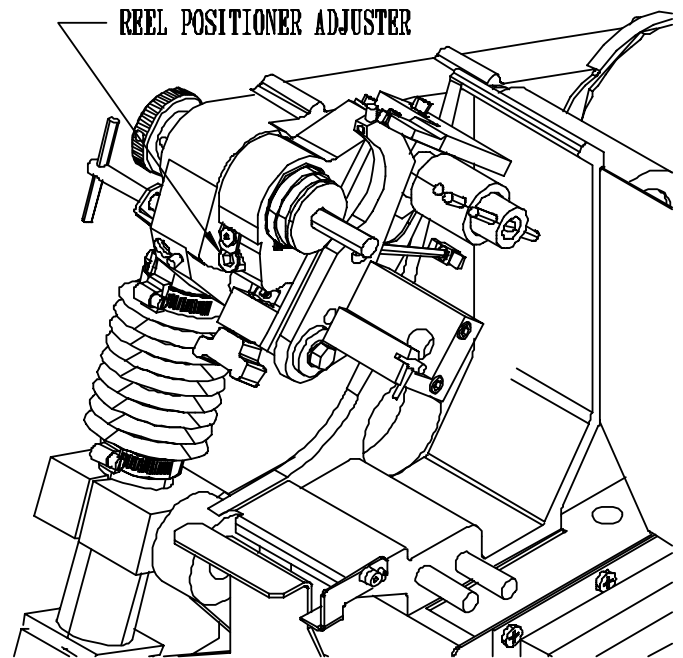

FIG. 9

SETTINGS INSTRUCTIONS



Safety Awareness Symbols are inserted in this manual to alert you to possible Safety Hazards. Whenever you see these symbols, heed their instructions.



The Warning Symbol identifies special instructions or procedures which, if not correctly followed, could result in personal injury.

The Caution Symbol identifies special instructions or procedures which, if not strictly observed, could result in damage to, or destruction of equipment.

PLEASE TAKE SPECIAL NOTE OF THE FOLLOWING WARNING DECALS LOCATED ON THE FRONT OF THE GRINDER, THE WINCH BOOM AND THE FRONT TOOLING BAR OF THE ACCU-Pro 630

WARNING

THIS GRINDER OPERATES WITH A LARGE AMOUNT OF HOT SPARKS, WHEN GRINDING A UNIT WITH A FUEL TANK, MAKE CERTAIN THERE IS NO EXPOSED FUEL AND THAT THE GAS CAP IS TIGHT AND THE VENT TAPED SHUT. CLOSE DOORS AND LATCH PRIOR TO GRINDING IN AUTO PROGRAM OR MANUAL JOG CYCLE.



Symbol for maximum weight capacity for winch



Symbol to keep exposed gasoline or flammables away from the grinder because it operates with a large amount of sparks.

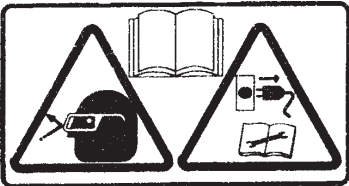

Symbol for Read operators manual, wear safety glasses and disconnect power before servicing.



Symbol to keep visitors a safe distance away from the grinder.



Symbol for sharp object which will cause serious injury.



Symbol for hot surface which could cause burns.



Symbol for caution relating to RPM of the motor and minimum safe rated RPM of the grinding wheel.



Symbol identifying a panel, cover, or area as having live electrical components within.

SAFETY INSTRUCTIONS (CONT.)

WARNING

FOR YOUR OWN SAFETY READ ASSEMBLY AND
OPERATING MANUAL BEFORE OPERATING

1. ALWAYS USE SAFETY GLASSES AND EAR PROTECTION.
2. DO NOT WEAR GLOVES, NECKTIES, LOOSE CLOTHING, ETC.
3. THIS MACHINE OPERATES WITH A LARGE AMOUNT OF HOT SPARKS. DO NOT OPERATE NEAR FLAMEABLES.
4. STAY CLEAR OF GRINDING WHEEL CONTACT AREA WHEN GRINDING. ALWAYS STAY CLEAR OF ALL ROTATING AND MOVING PARTS.
5. INSURE ADEQUATE DUST CONTROL BEFORE OPERATION.
6. ONLY PROPERLY TRAINED PERSONEL SHOULD OPERATE THE MACHINE. KEEP ALL VISTORS A SAFE DISTANCE FROM THE MACHINE.
7. BE CERTAIN THAT THE CUTTING UNIT IS SECURELY FASTENED WITH THE CLAMPS AND HANDLES PROVIDED BEFORE OPERATING.
8. DO NOT EVER EXCEED MAXIMUM OPERATING SPEED MARKED ON THE GRINDING WHEEL. (READ GRINDING WHEEL SAFETY SECTION IN YOUR MANUAL BEFORE GRINDING).
9. DISCONNECT YOUR MACHINE FROM THE MAIN POWER SOURCE BEFORE PERFORMING ANY ADJUSTMENTS, MECHANICAL SERVICING OR ELECTRICAL SERVICING.
10. WHEN MACHINE IS IN AUTOMATIC CYCLE, DO NOT LEAVE THE WORK AREA WITHOUT TURNING OFF POWER.
11. KEEP ALL GUARDS IN PLACE AND IN GOOD REPAIR.
12. BEFORE OPERATING INSPECT THE MACHINE FOR LOOSE, DAMAGED OR MISSING PARTS. IF FOUND, REPAIR OR REPLACE. REMOVE ALL TOOLS FROM OPERATING AREA.

-- SEE MANUAL FOR PROPER GRINDING INSTRUCTIONS --

WARNING

1. LIFTING WINCH
CAPACITY 400 LBS.
MAXIMUM.
2. ALWAYS HAVE THE
LIFTING HOOKS
SECURELY ATTACHED
AND BALANCED ON
THE CUTTING UNIT,
BEFORE LIFTING.
3. STAND WELL CLEAR
OF THE CUTTING UNIT
WHEN WINCHING INTO
POSITION. GUIDE WITH
EXTENDED ARM ONLY.
4. THE WINCH IS EQUIPPED
WITH A SAFETY RATCHET.
DO NOT DEFEAT OR
OVERRIDE THIS SAFETY
FEATURE.
5. READ WARNING LABEL
ON WINCH HANDLE
AND THE ASSEMBLY
AND OPERATING MANUAL
BEFORE USING THE WINCH.

OPERATING INSTRUCTIONS

PREPARE MOWING UNIT FOR SHARPENING

When preparing a cutting unit for sharpening, follow the cutting unit manufacturers recommendations for proper maintenance. It is recommended that the reel to be sharpened is thoroughly cleaned. Remove wheels and bed bar, if possible, from the reel. **All bedknives must be ground when reels are sharpened.** Inspect, adjust and/or replace any worn or damaged bearings. Make sure reel bearings are adjusted properly so the reel turns easily by hand.

Because this grinder mounts the reel using the reel roller, and front roller if applicable, the bearings must be in good repair with no freeplay. **The front and rear rollers must be properly aligned parallel to the reel prior to grinding.**



REELS WITH EXCESS TENSION ON THE BEARINGS WILL BE EXTREMELY DIFFICULT TO SPIN GRIND AND COULD CAUSE DAMAGE TO THE REEL OR THE SPIN DRIVE MECHANISM ON YOUR GRINDER. NO MORE THAN 25. IN. LBS MAXIMUM TORQUE LOAD TO ROTATE THE REEL IS ALLOWED OR DAMAGE TO THE SPIN DRIVE COULD OCCUR.

LIFTING REEL INTO POSITION

Position the reel in front of the grinder on the floor so the front of the mower faces towards the front of the machine. See FIG. 10 Hook the winch spreader bar onto the reel. The clamps on the bar should be spaced evenly along the mower, so they do not slide as the mower is being raised.

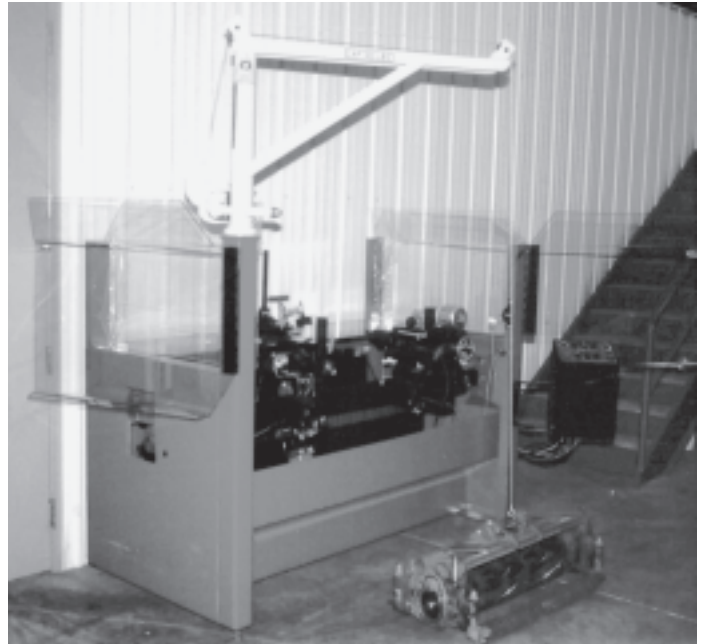

FIG. 10

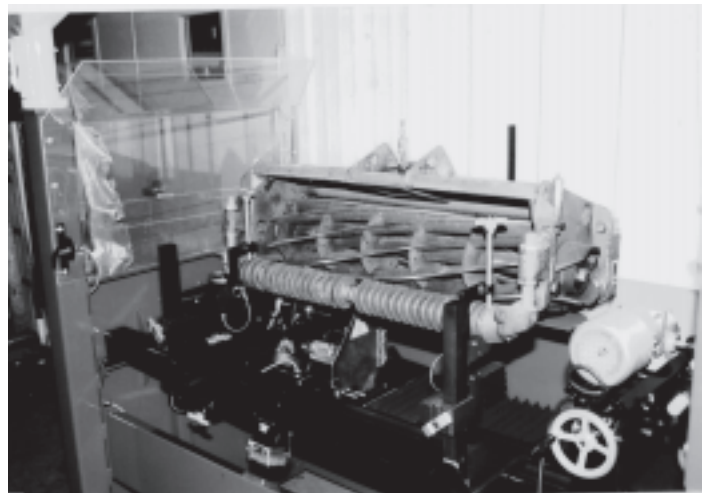

FIG. 11



THE OPERATOR SHOULD BE POSITIONED AWAY FROM THE REEL. DO NOT STAND UNDERNEATH THE REEL AS IT IS BEING RAISED. GUIDE REEL AT ARMS LENGTH.

SEE WINCH SAFETY WARNINGS AND INSTRUCTIONS ON PAGE 13.

OPERATING INSTRUCTIONS (Continued)

INSTALL REEL

Use the winch to lift the reel to the approximate position, having the rear roller on the table top, and front roller on front roller clamps. See FIG. 11.



MAKE SURE GRINDING WHEEL IS LOW ENOUGH TO CLEAR THE REEL. YOU CAN LOWER THE GRINDING WHEEL BY DEPRESSING THE INFEEED JOG BUTTON DOWN.

Position front roller clamps as far out as possible to the ends of the front roller, and center on the machine. See FIG. 11.

Set the vertical height of the clamps so the bottom of the reel is flush to 3/8" (10 mm) above the table surface. See FIG. 12.

Set the fore and aft position of the front clamps with the reel Positioning Gage. Place the reel positioner gage against gaging surface. See FIG. 13. You want to align the center of the reel within the slot of the positioner gage.



THE HORIZONTAL SCALES AND VERTICAL TOOLING SCALES MUST MATCH (LEFT AND RIGHT) FOR PROPER ALIGNMENT.

For greensmower reels, the 3 1/2" (8 mm) diameter grinding wheel must clear the front roller V-bracket by approximately 1/4" (6mm).

Make certain the reel is parallel to the front edge of the table. Lock down with front clamps and rear clamp. See FIG. 14 & 15.



FIRMLY TIGHTEN ALL LOCKING KNOBS BEFORE GRINDING. ANY LOOSENESS WILL ADVERSELY AFFECT GRINDING QUALITY.

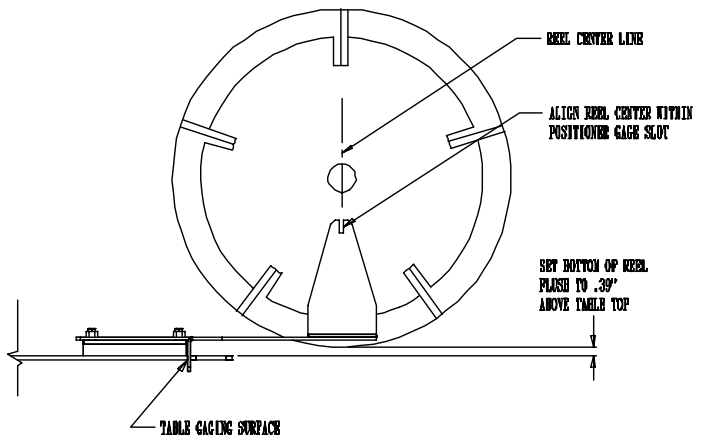

FIG. 12

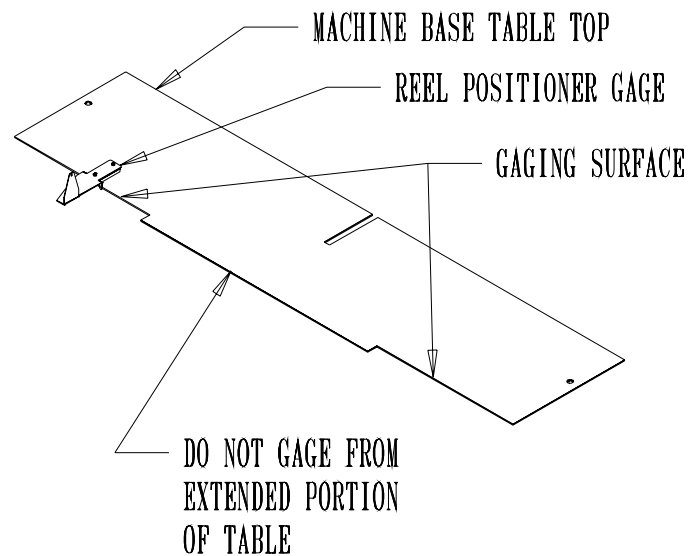

FIG. 13

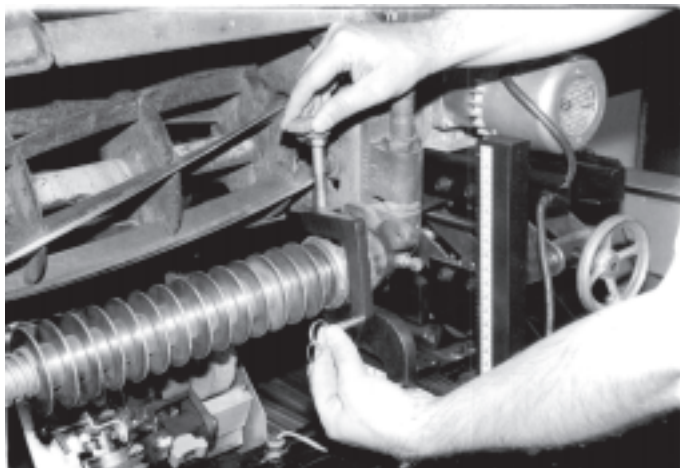

FIG. 15

OPERATING INSTRUCTIONS (Continued)

ALIGN THE REEL

NOTE: When measuring to the reel center shaft always make sure you are contacting an area free of dirt and grass.

Install the horizontal extension bracket onto the carriage front dowel pin and lock in place with knob. See FIG. 16.

Install the digital alignment gage onto the horizontal extension bracket pointing at the center of the reel shaft and lock into place with knob. See FIG. 17.

NOTE: The horizontal extension bracket is vertically adjustable so the digital gage can be positioned to avoid reel frame members, etc. The mounting of the vertical slide to the horizontal weldment has two additional mounting holes so the vertical slide can be tipped forward or back, again to avoid reel frame members, etc. See FIG. 16.

Loosen the two locking handles on the pivot assembly on the right side of the traverse base, so that it can be adjusted in both the vertical and horizontal plane. See FIG. 18.

First, measure the left side of the reel as far to the left as possible with the digital alignment gages, making sure the tip of the gage is centered on the reel center shaft. Set the gage to zero, then measure the right side at the same distance from reel centerline as the left side. Do not rotate the reel shaft except for a minimum amount to clear the gage when taking measurements. Adjust the horizontal handwheel. See FIG. 18. Repeat until alignment is within .002" (.05 mm). Lock the horizontal locking handle when done.

Remove the gage.

Remove the horizontal extension bracket and store it on the mount located on the outside of the right side grinder leg.

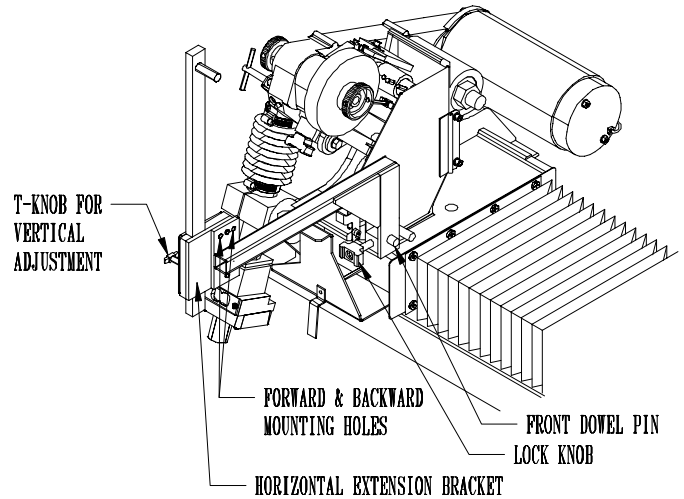

FIG. 16

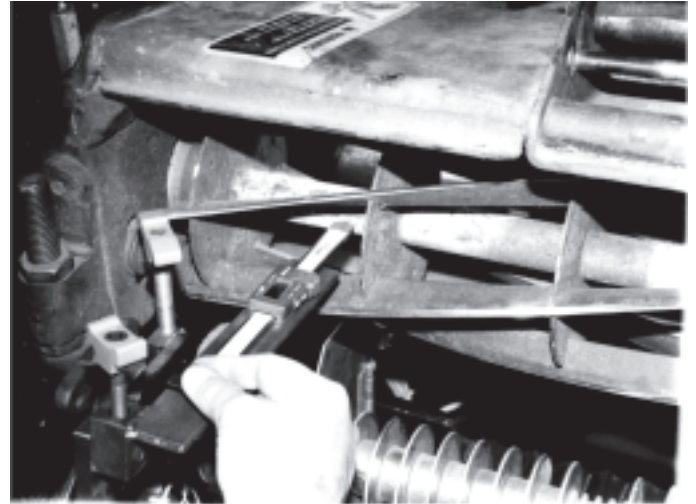

FIG. 17

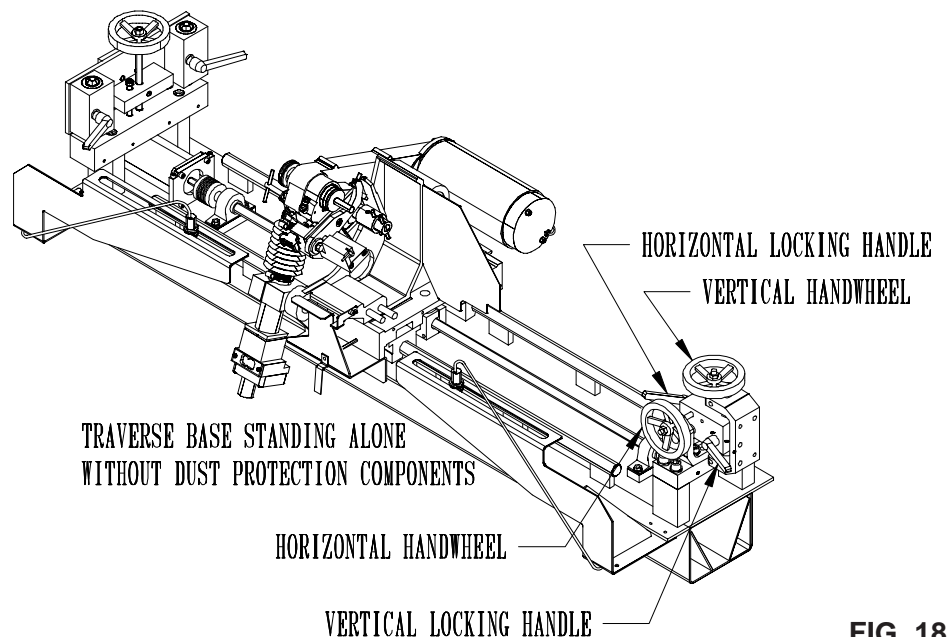

FIG. 18

OPERATING INSTRUCTIONS (Continued)

Install the digital alignment gage vertically on the carriage front dowel pin and pointing at the center of the reel shaft. Lock into place with knob. See FIG. 19 & 21.

First, measure the left side of the reel as far to the left as possible, set the gage to zero, then measure the right side, at the same distance from reel centerline as the left side. See FIG. 20. Do not rotate the reel shaft except for a minimum amount to clear the gage when taking measurements. Adjust the vertical handwheel. See FIG. 18. Repeat until alignment is within .002" (.05 mm). Lock the vertical locking handle when done. Remove and store the gage on the mount located on the inside of the right side grinder leg.

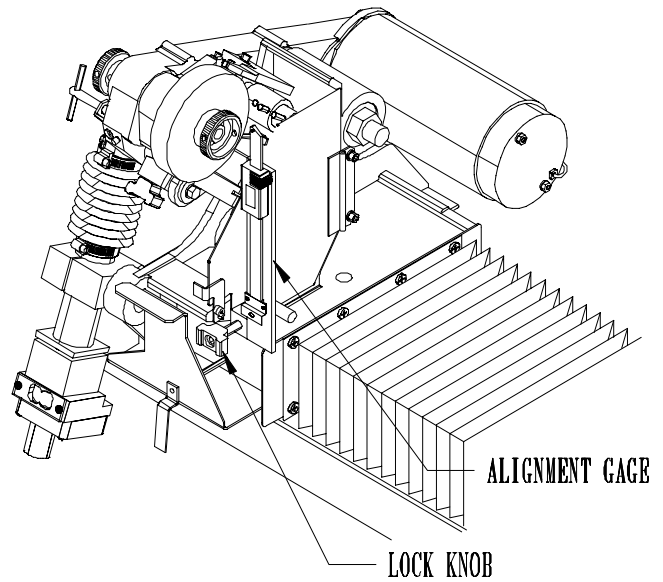

FIG.19

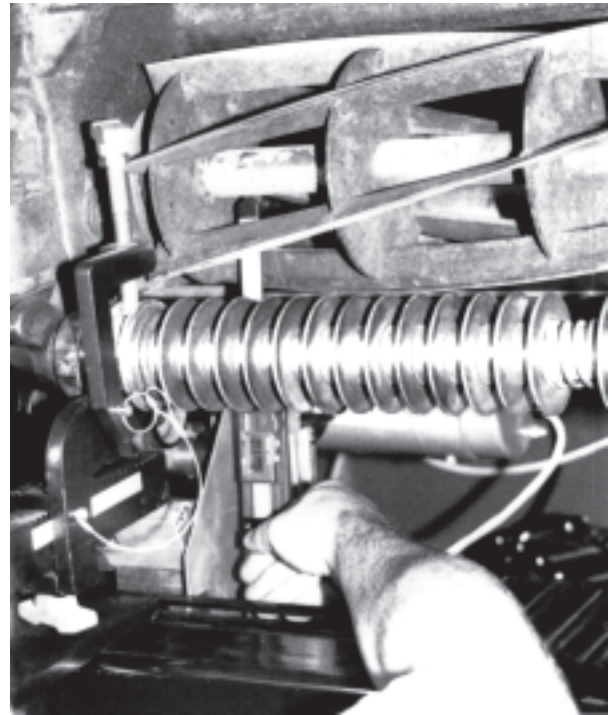

FIG. 20

FIG.21

OPERATING INSTRUCTIONS (Continued)

ATTACHING THE VARIABLE SPEED SPIN DRIVE UNIT TO THE REEL

The spin drive unit attaches to the end of the reel shaft or a drive system component. Consult the cutting unit manufacturer for proper spin drive placement and attachment. Determine which side to mount the spin drive. This will generally be the same drive system component used for backlapping. See FIG. 22.

Attach the spin drive unit onto the appropriate side.

When spin grinding, the reel should turn in the same direction as the grinding wheel. See FIG. 23.

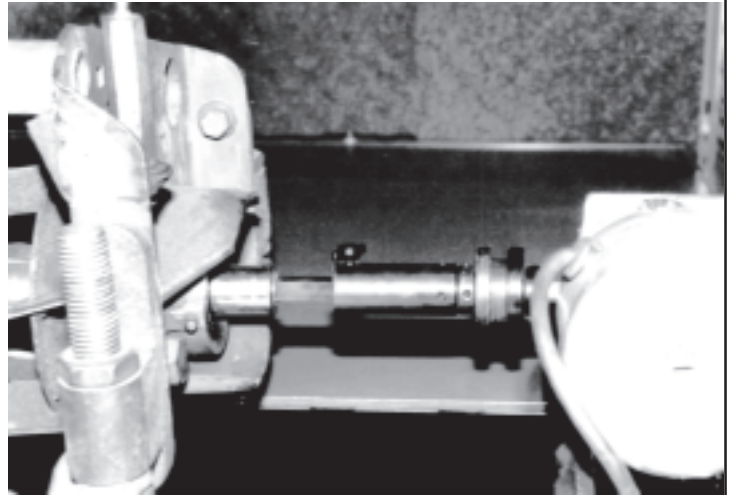

FIG. 22

Before positioning the spin unit let us familiarize ourselves with the available adjustments and coupler/drive assemblies. See FIG. 24.

KNOB A--

Adjust the scissor bar to move the unit up and down.

KNOB B--(2 each)

Allows the spin unit to be loosened and moved in and out.

KNOB C & D--

Allow the spin assembly to be loosened from the support bar frame and moved side to side.

When positioning the spin unit it will be necessary to complete several of the above adjustments to properly align the spin unit to the reel.

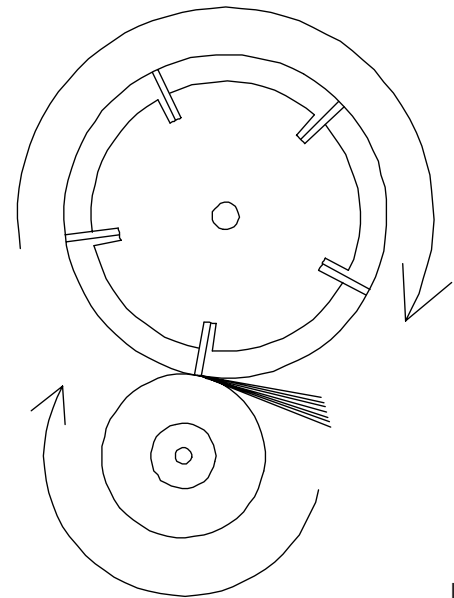

FIG. 23

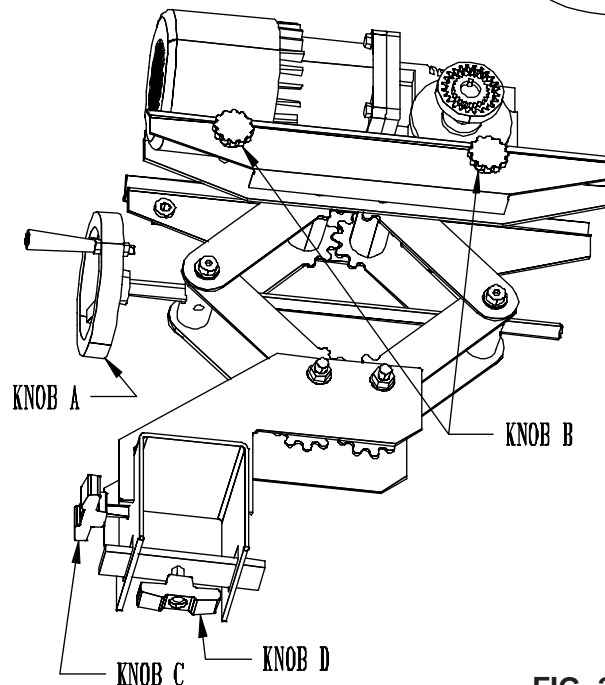

FIG. 24

OPERATING INSTRUCTIONS (Continued)

The coupler/drive assembly includes:

RUBBER SLEEVE COUPLER: This is placed in the corresponding flange coupler already mounted in the spin drive shaft. See FIG. 25.

DRIVE COUPLER ADAPTER ASSEMBLY: This is mounted to the rubber coupler.

ADAPTERSLEEVE: Connects the rubber coupler to the square drive adapter.

SQUARE DRIVE ADAPTER: This is inserted into the drive coupler adapter and should be able to be moved approximately 2" (51 mm). It will be necessary to move this when attaching reel to spin drive unit. It is then inserted into any 1/2" square drive socket. This square shaft has a groove machined into it on the opposite end of the snap ring. This groove is there to advise that you have reached the maximum extension of the square drive shaft. If you cannot connect the reel without extending past this groove, then the spin unit must be repositioned on the tooling bar (knobs C & D).

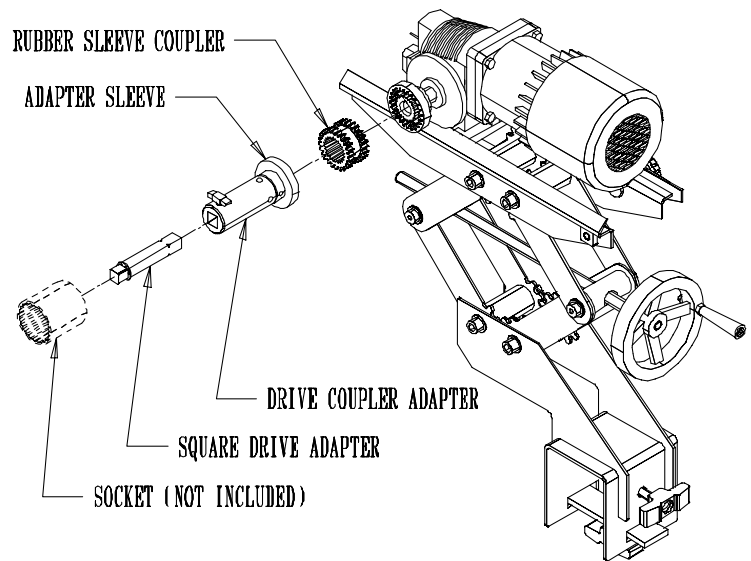

FIG. 25

NOTE: The 1/2" square drive socket that is placed on the reel when spin grinding is **NOT** included with the grinder. You must purchase this from the appropriate local supplier of tools. Some mowing units do not have a hex to use for driving with a socket. Several adapters are available from the grinder manufacturer. Additionally, you will have to make custom adapters for some mowing units.



DO NOT EXTEND SQUARE SHAFT PAST GROOVE, INSTEAD REPOSITION SPIN UNIT.

The following procedures will make setting up the spin drive unit easier.

1. Move spin drive unit close to the reel. Align the shaft on the spin drive with the nut on reel by completing the necessary adjustments discussed on the previous page.
2. Now slide the spin drive unit approximately 7" (18 cm) from the reel drive coupling point and securely fasten to the square mounting bar tightening both locking knobs. (Knobs C & D)
3. Place the proper 1/2" square drive socket or adapter on the reel drive nut and then insert the square drive shaft into the socket. Place the adapter sleeve over the drive shaft and insert the drive coupler adapter assembly into it. Finally place the rubber coupler onto the drive coupler adapter. See FIG. 22
4. By holding the square drive shaft firmly into position with your left hand you will be able to move the other components to the right and insert the rubber coupler into the flange on the spin drive unit. When this is done tighten the T-Knob on the adapter sleeve to hold all parts in place.
5. Finally readjust the spin drive unit if it is not in alignment.

NOTE: It is not necessary to have perfect alignment but it must be close enough so that the coupler remains engaged and that excess torque is not applied to the reel.

OPERATING INSTRUCTIONS (Continued)

SETUP PROCEDURE FOR SPIN DRIVE RPM VERSUS TRANSVERSE SPEED

SPIN DRIVE RPM

SPIN DRIVE RPM IS VERY IMPORTANT IN ACHIEVING A QUALITY GRIND. USE CARE IN ESTABLISHING THE SPIN DRIVE RPM, PER THE INSTRUCTIONS BELOW.

Generally, the Spin Drive RPM will be between 180 RPM (45%) and 380 RPM (100%). The speed required to spin a specific reel is dependant on reel diameter, the number of reel blades, and reel hardness. For all reels, there is an optimum Spin Speed where there is an **AGGRESSIVE**, yet smooth grind as you spin grind the reel. Your objective is to spin grind the reel as aggressively and as fast as possible while maintaining top quality.

It is recommended to start grinding each reel at a Spin Speed of 200 RPM (50%) and evaluate the RPM by adjusting higher and lower to optimize the Spin Speed for that reel. If the Spin Speed is incorrectly set, you can experience two problems, grinding wheel dressing or grinding wheel resonance. Each of these problems is explained below.

On some reels, especially small diameter high blade count reels if the Spin Speed RPM is set to high, the reel can act as a dresser to the grinding wheel. There can develop what appears to be a very aggressive grind (as if the infeed has self infed) and then a sudden stop of grinding with no grinding wheel to reel contact. If this occurs, your Spin Speed was set to high and you effectively dressed your grinding wheel.

Some reels have a resonant RPM where the reel goes into harmonics with the grinding wheel and the resonance vibrates the grinder and results in a very bad grind. By changing the Spin Speed to a higher or lower RPM you will move out of the resonant range.

After determining the best Spin Speed RPM for a reel, note the RPM on the "Set-up Chart" in the "NOTES" section. See page 34. By noting the correct RPM, you will avoid evaluating the Spin Speed the next time you grind the reel.

TRAVERSE DRIVE RPM

The Traverse Speed potentiometer is adjustable from approximately 5 feet per minute [1.5 meters per minute] to 35 feet per minute [10 meters per minute]. It is recommended to grind between 15 and 20 feet per minute [4 and 6 meters per minute].

OPERATING INSTRUCTIONS (Continued)

VERIFY GRINDING WHEEL TO REEL END FRAME CLEARANCE

Install the 5" (127 mm) x 1" (25mm) grinding wheel. Adjust the relief finger with the front hand knob so it clears the grinding wheel diameter (about 1/32" [0.8 mm]). Turn knob clockwise to move finger out and counter clockwise to move finger in. See FIG. 27.

NOTE: The 3 1/2" x 1" (88 mm x 25 mm) grinding wheel may be required for smaller reels, such as 5" (127 mm) diameter greensmowers, if clearance is required.

Pull the left side Plunger Pin and rotate the Finger and Body Assembly down (forward toward the operator) to the spin position until the left side plunger pin locks into position. See FIG. 28.

Position the index finger down and locked (pin in), with right side locking index finger pin. See FIG. 28

Move the grinding wheel up to within at least 1/8" (3 mm) of reel by depressing the Infeed Jog button up.

Move the Traverse Travel Limit switches out to allow the grinding wheel to reach the end of the reel. See FIG. 29. Turn on the traverse motor to move the grinding wheel until it has cleared the end of the reel (if clearance to the frame allows). When grinding wheel is in position, move the Traverse Travel Limit switches in until the red light on the proximity switch lights. Allow the carriage to traverse from end to end to verify switch properly stops grinding wheel.

! IF THE REEL FRAME EXTENDS PAST THE REEL ITSELF, MAKE SURE THE STOP IS SET SO THAT THE GRINDING WHEEL WILL NOT RUN INTO FRAME WHEN GRINDING.

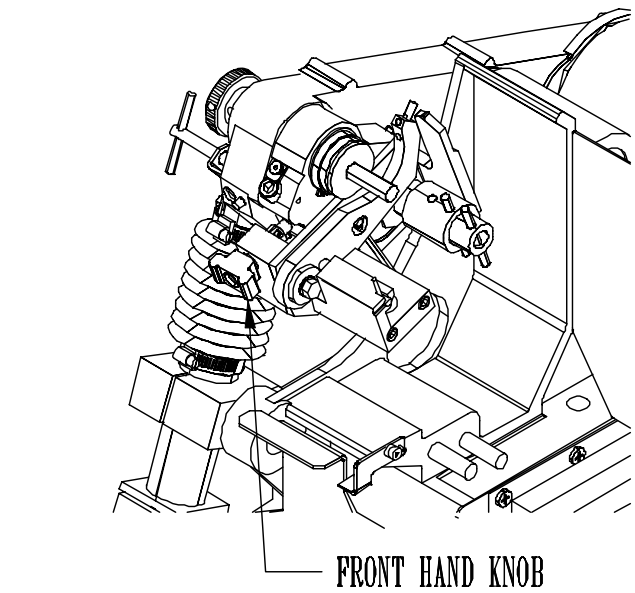

FIG. 27

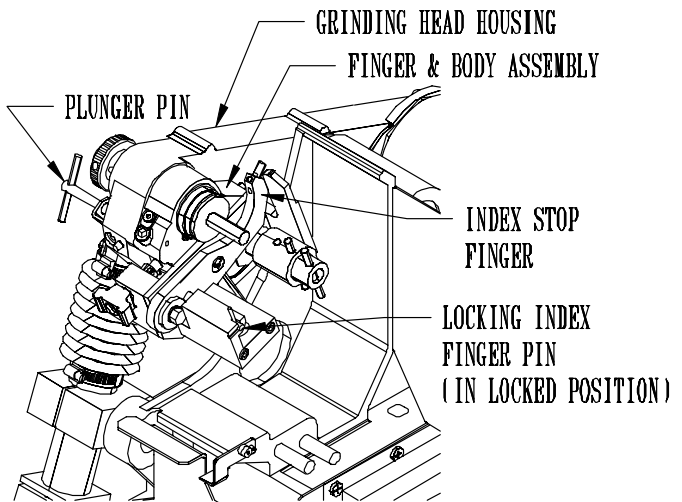

FIG. 28



FIG. 29.

Put the Grind selector switch to Variable Speed Spin.

NOTE: The Spin Drive Rotation Switch must be in the off position when changing Grind Selector Switch.

Close and latch guard doors. (The grinding wheel motor will not work unless the doors are closed).

OPERATING INSTRUCTIONS (Continued)

Turn on the Grinding Wheel Motor and the Spin Drive Motor. Set the Spin speed at approximately 210 rpm for 10" (254 mm) reels and 400 rpm for 5" (127 MM) reels. (Refer to Spin Drive Speed Chart). Make sure spin rotation is the same as the grinding wheel - clockwise (CW) looking from right end. See FIG. 30.

NOTE: When the reel turns in the same rotation as the grinding wheel, the point of contact where they meet is in opposite directions.

Depress infeed jog button until you spark off on the reel.

Turn the traverse drive motor on to traverse across the reel finding the high side. NOTE: If the grind starts getting heavier, jog the infeed down again until you can travel the full length of the reel without heavy grinding.

NOTE: If you find excessive differences from one side to the other (more than 1/16 [1.5 mm]) you may want to re-verify alignment before going further.

When you are able to travel the full distance of the reel without any problems proceed with grinding the reel. You want to infeed the Grinding Wheel approximately .005" at a time. This is measured by the calibration ring on the infeed motor. (See FIG. 31). Allow the Grinding Wheel to travel back and forth across the reel 2 to 3 times before infeeding further.

When enough material has been removed, the spin grinding is completed when full contact is made across the entire length of the reel and the entire width of all blades. It is required to have a sparkout to complete grinding the outside diameter to a true diameter. For sparking out, the process is to infeed the grinding head for approximately .002 stock removal (two lines on the ring scale) and let the grinding wheel sparkout. For sparking out in grinding process, always traverse grinding head an adequate number of times to get finish quality you require with no grinding head infeed. Set traverse at slow speed on dial setting, the slower, the better finish, approx. 8 feet per minute or slower is recommended, but adjust the speed to your finish requirements, for final grinding sparkout. After sparkout, shut the grinder completely off.

NOTE: This process refers to sparkout, but what we are looking for is near sparkout, a reduction in grinding sparks from normal grind which assures that the reel is fully and uniformly ground. Do not run sparkout until you have no sparks because this could be an extremely extended period.

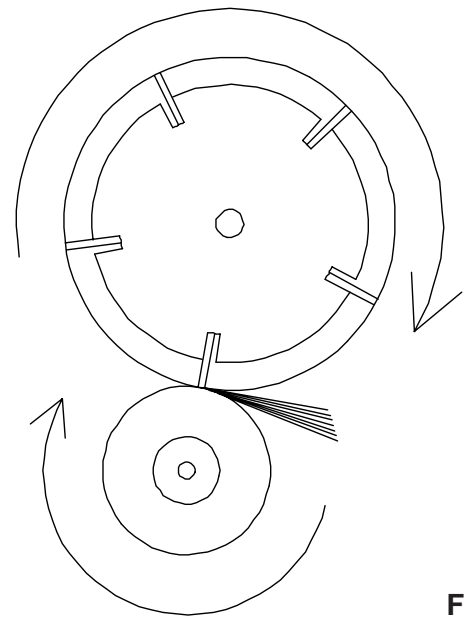

FIG. 30

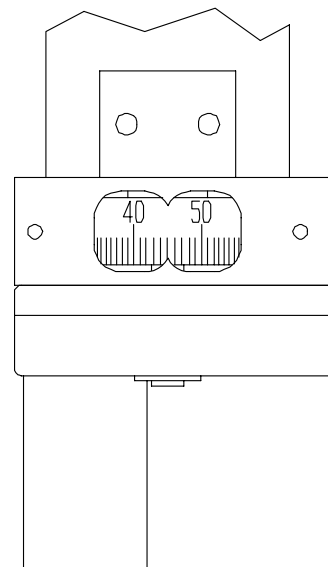

FIG. 31

NOTE: Each line on the calibration ring is .001" infeed.

OPERATING INSTRUCTIONS (Continued)

RELIEF GRIND

Replace the grinding wheel with the appropriate wheel for relief grinding. Generally a 5" (127 mm) Dia. x 3/8" (10 mm) wide, will be used. As the reel diameter gets smaller and the number of blades increases the relief grinding wheel diameter must get smaller. That is why a 5" Dia. (127 mm) x 3/8" (10mm) wide and a 3 1/2" Dia. (88 mm) wide wheel are furnished with the grinder. As a general rule, use the largest grinding wheel practical to relief grind. **NOTE:** 5" 127 MM) diameter greensmower reels with 11 blades require a 3.5" (89 mm) diameter or smaller grinding wheel. Adjust the relief guide finger with the front hand knob so it slightly misses the smaller grinding wheel diameter (about 1/32" [1 mm]).

REEL SPIRAL

Check to see if your mowing unit is normal or reverse helix.

NOTE: As you look into the guide finger on **PAGE 29**, **IT SHOWS THE NORMAL REEL HELIX.** The high point of the relief finger is on the right hand side of the grinding wheel.

As you look into the guide finger on **PAGE 30**, **IT SHOWS THE REVERSE REEL HELIX.** The high point of the relief finger is on the right hand side of the grinding wheel.

Most mowing units are normal helix.



THE HIGH POINT OF THE RELIEF FINGER MUST ALWAYS BE AT THE CORNER OF THE GRINDING WHEEL THAT IS MAKING CONTACT WITH THE REEL. ON THIS GRINDER THAT IS ALWAYS THE RIGHT HAND SIDE OF THE GRINDING WHEEL. SEE PAGES 29 AND 30.

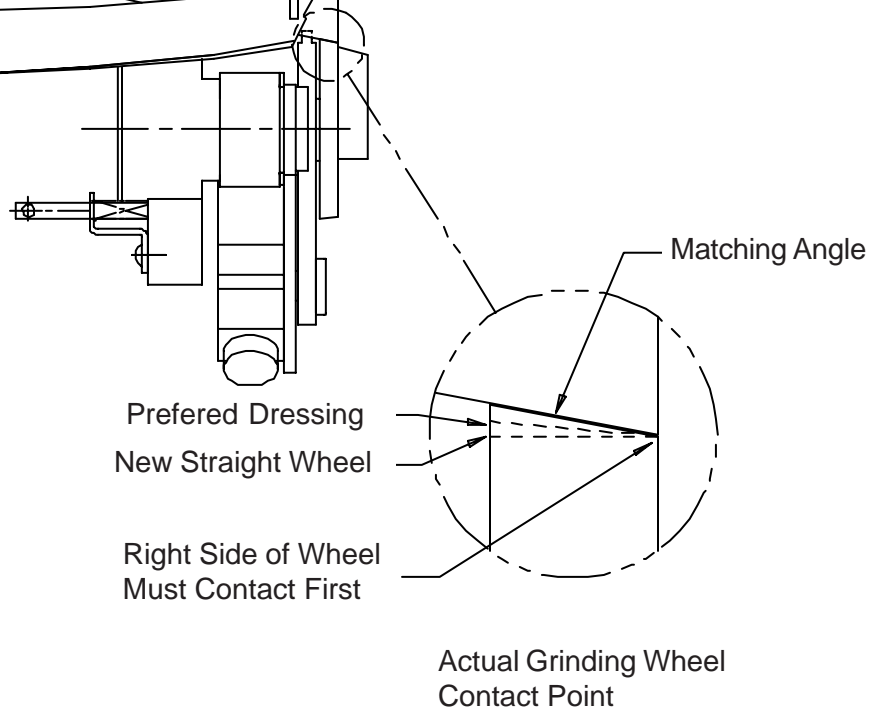
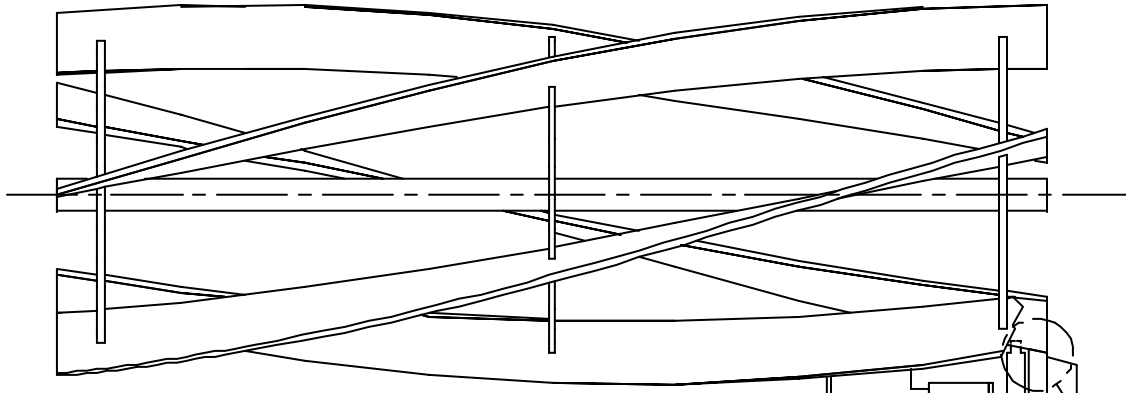

NORMAL HELIX

For a NORMAL HELIX reel, the grinding wheel should wear to match the angle of the reel blade.

NOTE: The square faced grinding wheel as from the factory can be used for normal helix reels and will wear to match the reel blade helix.

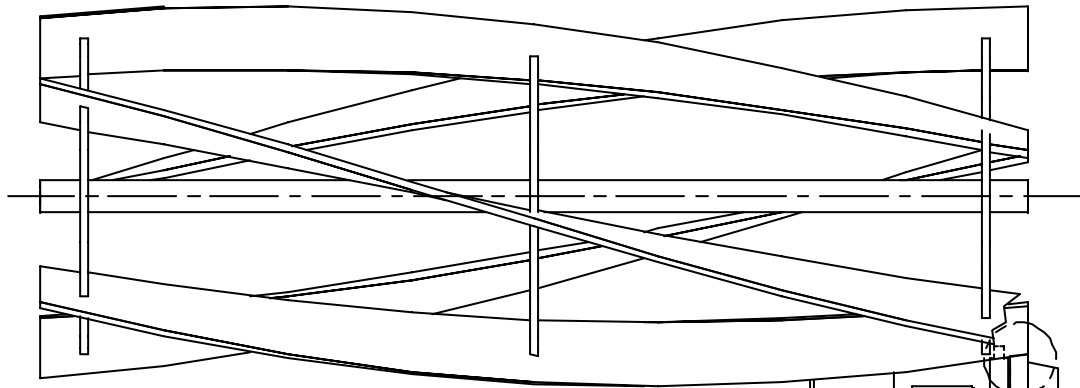

REVERSE HELIX

For a REVERSE HELIX reel, the grinding wheel should be a wheel that has been used for NORMAL HELIX reels and has worn to match the angle of the reel blade which is reversed to match the angle as illustrated.

If you do not use a preworn grinding wheel so the right side contacts first you may not relief grind part of the last 3/8" [10 mm] of the blade.

NOTE: A wheel that has been worn to match a normal helix can generally be removed and reversed to grinder reverse helix reels.

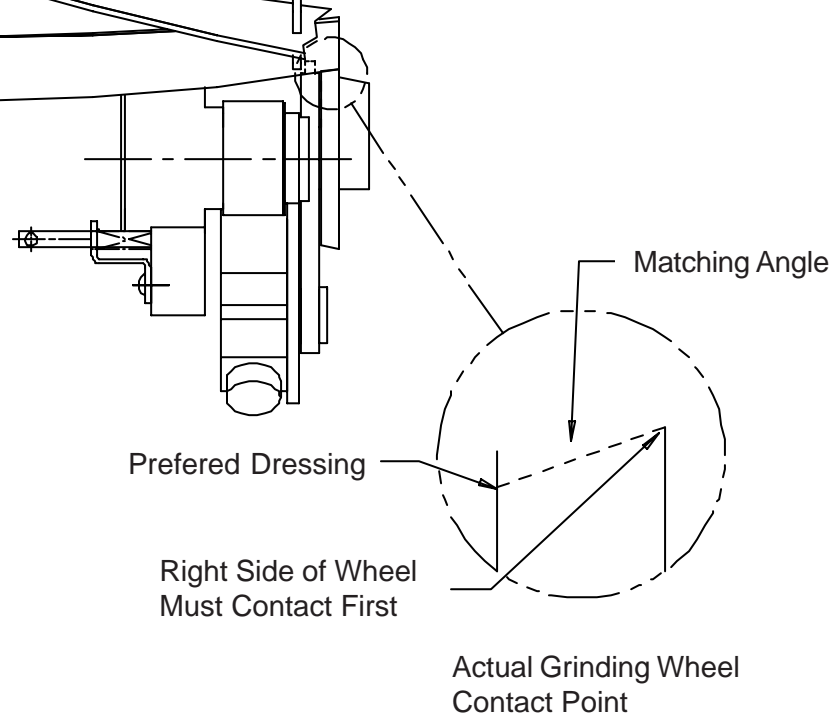

OPERATING INSTRUCTIONS (Continued)

Reset the Traverse Limit Proximity Switch so the grinding wheel clears the reel at both ends by approximately 1/16" (1.5 mm).

Pull the left side plunger pin and rotate the Finger and Body Assembly up (back, away from the operator) into the relief position until the left side plunger pin locks into position. See FIG. 32.

Pull the right side locking index finger pin to release the index finger and rotate the handle into the retracted position. See FIG. 32.

Set Grind Selector to variable torque relief. (**NOTE:** The Spin Drive Rotation switch must be in the **OFF** position when changing Grind Selector switch.) Set Spin Drive Rotation switch to rotate the reel into the stop finger, counterclockwise (CCW) when looking at the right side. **NOTE:** Relief torque reel rotation is always opposite spin rotation.

With the traverse in home position, jog the grinding head up while manually rotating the reel until the index finger touches the blade.

NOTE: The Index Finger position must be set to stop the reel blade and allow traversing to the left without the blade hitting the side of the relief finger. This position must also allow approximately 1/32" (1 mm) free play of the index finger when the blade is resting on the high point of the relief finger. See FIG. 32.

Turn the traverse speed pot to zero, then turn the traverse drive motor on. Using the speed pot to slowly move and stop the grinding wheel, jog left until the reel blade is on the relief finger. Adjust the index finger positioning by loosening the Index Lock Handle and rotating the index adjust lever on the right side of the grinding head*. See FIG. 32. When this is completed, lock it into position by tightening the index lock handle.*

Continue to jog the grinding head up until there is minimal clearance between the reel blade and the grinding wheel.

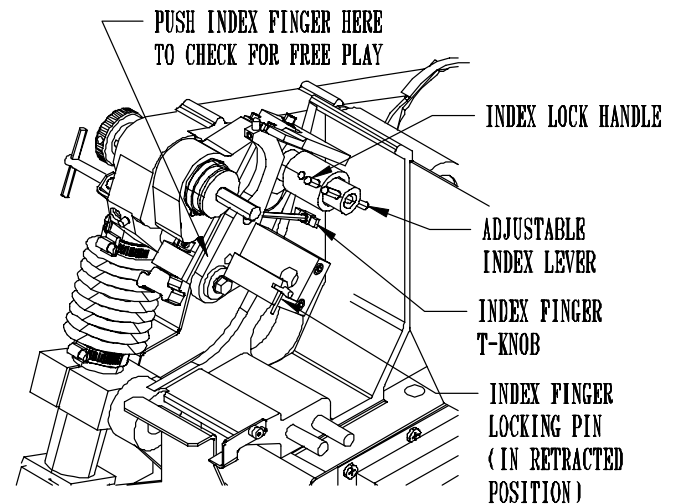

DETAIL SHOWS FINGER & BODY ASSEMBLY ROTATED (COUNTER CLOCKWISE) INTO RELIEF GRINDING POSITION (SHOWN WITHOUT GRINDING WHEEL FOR CLARITY)

FIG. 32

OPERATING INSTRUCTIONS (Continued)

Turn the Spin Drive motor on.

NOTE: The spin drive will apply torque load against the fingers.

Set the Relief Torque Potentiometer at approximately 15. **NOTE:** Free turning reels may need a lower value than 15. Stiff reels or reels with a drive train may need a higher torque than 15. Do not exceed 45 on the relief torque potentiometer setting.

Jog the traverse all the way to the left watching for proper clearance between the grinding wheel and the blade. Check for proper clearance between the index finger (after releasing from blade at far left position) and the front side of the blade on the return trip to the home position. Also verify clearance to the reel blade support spiders.

Stop the traverse in home position and check for a proper blade index. The traverse drive control is factory set with a two second dwell time before it reverses the carriage travel. This is to allow time for the reel to rotate and the index finger to catch the next blade. If necessary the dwell time can be adjusted (refer to Control Board Potentiometer Adjustments section on Pages 22-24 in the Assembly and Service Manual).

At this point, you can adjust the relief angle by turning the Reel Positioner Adjuster. See FIG. 33. You can increase the relief angle approximately 8 degrees by rotating the Reel Positioner Adjuster clockwise. You can decrease the relief angle approximately 8 degrees by rotating the Reel Positioner Adjuster counterclockwise.

Close and latch doors.

Turn on the Spin Drive Motor (should already be on) and the Grinding Wheel Motor.

Turn on the traverse speed pot to proper grinding speed. Slowly infeed grinding wheel until you are able to grind the full length of reel evenly. You can infeed between .005" to .012" at a time. Be sure you have ground all the blades before infeeding further.

NOTE: Traverse speed should be approximately 15 fpm. If you are removing a small amount of stock on initial infeeds, faster traverse speeds are suggested. If you are removing a large amount of stock on later infeeds, slower traverse speed may be required.

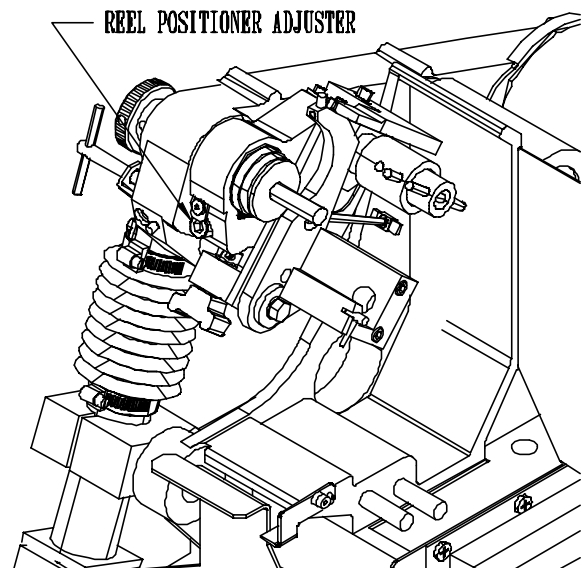

FIG. 33

--This page intentionally left blank for note taking purposes.--

