



*Setting the Standard with the
Worlds Most Valued Grinders*

605
ACCU - SHARP
AUTO-INDEX
SPIN / RELIEF
REEL MOWER GRINDER

THIS BOOK CONSISTS OF TWO MANUALS:

**THE OPERATORS MANUAL WHICH CONTAINS ALL THE INFORMATION ON
OPERATING AND DOING ROUTINE DAILY MAINTENANCE ON THIS EQUIPMENT.**

**THE ASSEMBLY AND SERVICE MANUAL WHICH IS USED BY THE MAINTENANCE
DEPARTMENT TO INSTALL THE EQUIPMENT AND TO DO ALL MAINTENANCE
EXCEPT ROUTINE DAILY MAINTENANCE.**



*Setting the Standard with the
Worlds Most Valued Grinders*

We are committed to:

Providing superior customer support, training, and service.

Manufacturing the highest quality products at an unequaled value.

Setting the industry standard by investing in technological product innovation.

Manufacturing products specifically designed to maintain original equipment manufacturers' specifications.

Interacting with and supporting all original equipment manufacturers.

605
ACCU - SHARP
AUTO-INDEX
SPIN / RELIEF
REEL MOWER GRINDER

PATENT NO. 6,010,394
6,290,581 & 6,685,544

OPERATORS
MANUAL

 **WARNING**

**YOU MUST THOROUGHLY READ AND UNDERSTAND THIS MANUAL
BEFORE OPERATING THE EQUIPMENT, PAYING PARTICULAR
ATTENTION TO THE WARNING & SAFETY INSTRUCTIONS.**





IMPORTANT SAFETY MESSAGE



This manual will cover the operation of this Reel Mower Grinder. There is an additional manual that addresses the installation and service of this equipment. As manufacturers of reel grinders, we want to confirm to you, our customers, our concern for safety. We also want to remind you about the simple, basic, and common sense rules of safety when using a reel grinder. Failure to follow these rules can result in severe injury or death to operators or bystanders.

It is essential that everyone involved in the assembly, operation, transport, maintenance, and storage of this equipment be aware, concerned, prudent, and properly trained in safety. Always use proper shielding and personal protective equipment as specified by the manufacturer.

Our current production machines include, as standard equipment, guards or shields for the grinding wheel, safety signs, and operators and service manuals. Never bypass or operate the machine with any of the guards or safety devices removed or without the proper personal safety equipment.

Read and fully understand all the safety practices discussed in this manual. All safety rules must be understood and followed by anyone who works with reel grinders.

Before operating a reel grinder, an operator must read and understand all of the information in the operators manual and understand all the safety signs attached to the product. A person who has not read or understood the operators manual and safety signs is not qualified to operate the unit. Accidents occur often on machines that are used by someone who has not read the operators manual and is not familiar with the equipment. If you do not have an operators manual or current production safety signs, contact the manufacturer or your dealer immediately.

Reel grinders are designed for one-man operation. Never operate the grinder with anyone near, or in contact with, any part of the grinder. Be sure no one else, including bystanders, are near you when you operate this product.

Following these simple, basic safety rules, as well as others:

Find and understand all safety signs in the operators manual and on the equipment. This will help minimize the possibility of accidents and increase your productivity in using this product. Be careful and make sure that everyone who operates the grinder knows and understands that it is a very powerful piece of machinery, and if used improperly, serious injury or death may result. The final responsibility for safety rests with the operator of this machine.

THROUGHOUT THIS MANUAL, THE FOLLOWING SAFETY SYMBOLS WILL BE USED TO INDICATE THE DEGREE OF CERTAIN HAZARDS.



This symbol is used throughout this manual to call attention to the safety procedures.

 **DANGER**

The word DANGER indicates an immediate hazardous situation, which if not avoided, will result in death or serious injury.

 **WARNING**

The word WARNING indicates a potential hazardous situation, which if not avoided, could result in death or serious injury.

 **CAUTION**

The word CAUTION preceded with a safety alert symbol indicates a potential hazardous situation which, if not avoided, may result in minor or moderate injury.

TABLE OF CONTENTS

Safety Message.....	4
Safety Instructions.....	5-11
Getting to Know your Grinder	12-13
Operating Instructions.....	14-42
Setup Chart.....	43

Read this manual before operating this equipment. Keep this manual handy for ready reference. Require all operators to read this manual carefully and become acquainted with all adjustments and operating procedures before attempting to operate the equipment. Replacement manuals can be obtained from your selling dealer or the manufacturer.

The equipment you have purchased has been carefully engineered and manufactured to provide dependable and satisfactory use. Like all mechanical products, it will require cleaning and upkeep. Lubricate and clean the unit as specified. Please observe all safety information in this manual and safety decals on the equipment.

This machine is designed for sharpening reel type mower blades ONLY. Any use other than this may cause personal injury and void the warranty.



To assure the quality and safety of your machine and to maintain the warranty, you MUST use original equipment manufacturer's replacement parts and have any repair work done by a qualified professional.



ALL operators of this equipment must be thoroughly trained BEFORE operating the equipment.

Do not use compressed air to clean grinding dust from the machine. This dust can cause personal injury as well as damage to the grinder.

PREPARATION/INSTALLATION CHECK LIST

Before using this equipment refer to the list below. Verify that all of the listed items are completed before powering up the equipment:

- | | |
|--|---|
| <input type="checkbox"/> 1. Equipment is completely assembled | <input type="checkbox"/> 7. Understand proper positioning of reel. |
| <input type="checkbox"/> 2. All shields are in place and in good condition. | <input type="checkbox"/> 8. Understand the use of reel grinder relief mechanism |
| <input type="checkbox"/> 3. All decals are in place and readable. | <input type="checkbox"/> 9. Understand traverse proximity switch positioning |
| <input type="checkbox"/> 4. Overall condition good (i.e. paint, welds, electrical) | <input type="checkbox"/> 10. Understand use of the reel alignment gauge |
| <input type="checkbox"/> 5. Verify there is sufficient electrical power to operate the machine. | <input type="checkbox"/> 11. Understand spin speed vs. quality |
| <input type="checkbox"/> 6. Read and understand all areas of the Operators manual, and review the Assembly & Service Manuals, and any additional training material if available. | <input type="checkbox"/> 12. Understand the reel set-up chart in manual |
| | <input type="checkbox"/> 13. Understand General Maintenance |

SAFETY INSTRUCTIONS

Adjustable Reel Clamping Mechanisms for ease of installation. One chain vise grips included to secure any size roller.

Positive Vertical and Horizontal Reel Adjustments for fast alignment of the reel in the machine.

Dial Indicator Setup Gauge to align reels with accuracy up to .001".

Accessible Control Panel with independent switches for grinding motor, carriage traverse with variable speed control, spin drive with variable speed control, and a safety stop button.

Positive Infeed and height adjustment for exact positioning of the reel and measured metal removal.

Electro-Magnetic Traversing Switch for easily adjustable traversing length.

Front and Rear guard door
Guard door that open in front or behind the machine.



SPECIFICATIONS

Traversing Switches	Solid state, non-contacting proximity switches
Carriage Travel.....	45"[115 cm]
Overall Width	79.5"[202 cm]
Overall Height	83"[211 cm]
Overall Depth	48.5"[124 cm]
Weight.....	1290 lbs[585 kg]
Base Construction	Precision Machined heavy duty reinforced welded steel base
Carriage Rails.....	Precision Ground, Hardened Steel 1.000 Dia. [25.4 mm]
Grind Head Motor	1 HP at 60 HZ, 7/8 HP at 50 HZ, 3450 RPM at 60 HZ, 2875 RPM at 50 HZ
Elevator	400 lbs. [180 kg] capacity
Spin Drive	Reversible variable speed 0-380 RPM DC Gear Motor .20 Hp
Sound Level.....	More than 75 DbA, Less than 95 DbA
Auto Traverse	Belt drive
Rail covers	Telescoping bellows
Control System	Reversible Spin drive with variable spin speed or variable relief torque
Control System	Door safety interrupt switches and variable traverse speed control

OPERATING CONDITIONS: THIS MACHINE IS INTENDED FOR INDOOR USE ONLY.

AMBIENT TEMPERATURE:	+5°C/ 40°F to +40°C/ 100°F
RELATIVE HUMIDITY:	50% RH, +40°C / 100°F. Higher RH may be allowed at lower temperatures. - no condensation must be present.
ALTITUDE:	up to 1000m/ 3280 ft. above mean sea level.
TRANSPORTATION AND STORAGE:	-25°C/-15°F to +55°C / 130°F Means must be provided to prevent damage from humidity, vibration and shock.

SAFETY INSTRUCTIONS



WARNING

TO AVOID INJURY, READ AND UNDERSTAND THE SAFETY ITEMS LISTED BELOW. IF YOU DO NOT UNDERSTAND ANY PART OF THIS MANUAL AND NEED ASSISTANCE, CONTACT YOUR LOCAL DEALER OR THE MANUFACTURER.

- 1. KEEP GUARDS IN PLACE** and in working order.
- 2. REMOVE WRENCHES AND OTHER TOOLS.**
- 3. KEEP WORK AREA CLEAN.**
- 4. DON'T USE IN DANGEROUS ENVIRONMENT.**
Don't use the Grinder in damp or wet locations. Machine is for indoor use only. Keep the work area well lit.
- 5. KEEP ALL VISITORS AWAY.** All visitors should be kept a safe distance from the work area.
- 6. MAKE THE WORK AREA CHILD-PROOF** with padlocks or master switches.
- 7. DON'T FORCE THE GRINDER.** It will do the job better and safer if used as specified in this manual.
- 8. USE THE RIGHT TOOL.** Don't force the Grinder or an attachment to do a job for which it was not designed.
- 9. WEAR PROPER APPAREL.** Wear no loose clothing, gloves, neckties, or jewelry which may get caught in moving parts. Nonslip footwear is recommended. Wear protective hair covering to contain long hair. Wear respirator or filter mask where appropriate. Wear protective gloves.
- 10. ALWAYS USE SAFETY GLASSES.**
- 11. SECURE YOUR WORK.** Make certain that the cutting unit is securely fastened with the clamps provided before operating.
- 12. DON'T OVERREACH.** Keep proper footing and balance at all times.
- 13. MAINTAIN GRINDER WITH CARE.** Follow instructions in the Operators and Service Manual for lubrication and preventive maintenance.
- 14. DISCONNECT POWER BEFORE SERVICING,** or when changing the grinding wheel.
- 15. REDUCE THE RISK OF UNINTENTIONAL STARTING.** Make sure that all switches are OFF and the E-stop is pressed in before plugging in the Grinder.
- 16. USE RECOMMENDED ACCESSORIES.** Consult the manual for recommended accessories. Using improper accessories may cause risk of personal injury or damage to the equipment.
- 17. CHECK FOR DAMAGED PARTS.** A guard or other part that is damaged or will not perform its intended function should be properly repaired or replaced.
- 18. NEVER LEAVE THE GRINDER RUNNING UNATTENDED. TURN THE POWER OFF.** Do not leave grinder until it comes to a complete stop.
- 19. KNOW YOUR EQUIPMENT.** Read this manual carefully. Learn its application and limitations as well as the specific potential hazards.
- 20. KEEP ALL SAFETY DECALS CLEAN AND LEGIBLE.** If safety decals become damaged or illegible for any reason, replace immediately. Refer to replacement parts illustrations in Service Manual for the proper location and part numbers of safety decals.
- 21. DO NOT OPERATE GRINDER WHEN UNDER THE INFLUENCE OF DRUGS, ALCOHOL, OR MEDICATION.**

SAFETY INSTRUCTIONS



WARNING

IMPROPER USE OF GRINDING WHEEL MAY CAUSE BREAKAGE AND SERIOUS INJURY.

GRINDING IS A SAFE OPERATION IF THE FEW BASIC RULES LISTED BELOW ARE FOLLOWED. THESE RULES ARE BASED ON MATERIAL CONTAINED IN THE ANSI B7.1 SAFETY CODE FOR "USE, CARE AND PROTECTION OF ABRASIVE WHEELS". FOR YOUR SAFETY, WE SUGGEST YOU BENEFIT FROM THE EXPERIENCE OF OTHERS AND CAREFULLY FOLLOW THESE RULES.

DO

1. **DO** always **HANDLE AND STORE** wheels in a **CAREFUL** manner.
2. **DO VISUALLY INSPECT** all wheels before mounting for possible damage.
3. **DO CHECK MACHINE SPEED** against the established maximum safe operating speed marked on the wheel.
4. **DO CHECK MOUNTING FLANGES** for equal and correct diameter.
5. **DO USE MOUNTING BLOTTERS** that are supplied with the wheels.
6. **DO** be sure **WORK REST** is properly adjusted.
7. **DO** always **USE A SAFETY GUARD COVERING** at least one-half of the grinding wheel.
8. **DO** allow **NEWLY MOUNTED WHEELS** to run at operating speed, with guard in place, for at least one minute before grinding.
9. **DO** always **WEAR SAFETY GLASSES** or some type of approved eye protection when grinding.

DON'T

1. **DON'T** use a cracked wheel or one that **HAS BEEN DROPPED** or has become damaged.
2. **DON'T FORCE** a wheel onto the machine **OR ALTER** the size of the mounting hole - if the wheel won't fit the machine, get one that will.
3. **DON'T** ever **EXCEED THE MAXIMUM OPERATING SPEED** established for the wheel.
4. **DON'T** use mounting flanges on which the bearing surfaces **ARE NOT CLEAN, FLAT AND FREE OF BURRS.**
5. **DON'T TIGHTEN** the mounting nut excessively.
6. **DON'T** grind on the **SIDE OF THE WHEEL** (see Safety Code B7.2 for exception).
7. **DON'T** start the machine until the **WHEEL GUARD IS IN PLACE.**
8. **DON'T JAM** the work into the wheel.
9. **DON'T STAND DIRECTLY IN FRONT** of a grinding wheel whenever a grinder is started.
10. **DON'T FORCE THE GRINDING** so that motor slows noticeably or that the work piece gets hot.



WARNING

AVOID INHALATION OF DUST generated by grinding and cutting operations. Exposure to dust may cause respiratory ailments. Use approved NIOSH or MSHA respirators, safety glasses or face shields, and protective clothing. Provide adequate ventilation to eliminate dust, or to maintain dust level below the Threshold Limit Value for nuisance dust as classified by OSHA.

WARNING

CAREFULLY READ ALL THE INSTRUCTIONS BELOW BEFORE ATTEMPTING TO OPERATE OR SERVICE YOUR WINCH! FAILURE TO COMPLY WITH INSTRUCTIONS COULD RESULT IN PERSONAL INJURY, DEATH AND/OR PROPERTY DAMAGE!

1. Maximum lifting capacity is 400 pounds (180 kg.) in a single line operation. **DO NOT ATTEMPT TO MOVE LOADS GREATER THAN THE RATING.**
2. **NEVER CARRY** personnel on the hook or the load.
3. **NEVER MOVE A LOAD** with this winch until all personnel are clear.
4. **NEVER HOOK THE WIRE ROPE BACK ON ITSELF. USE THE SPREADER BAR ASSEMBLY.** Hooking the wire rope back on itself creates an unacceptable strain on the wire rope.
5. **DO NOT ALLOW** unqualified personnel to operate this unit.
6. **KEEP CLEAR OF WINCH WIRE ROPE AND HOOK WHEN OPERATING WINCH. DO NOT ATTEMPT** to guide wire rope by hand as it rewinds.
7. **DO NOT** use the wire rope as a ground for welding.
8. **NEVER TOUCH** a welding electrode to the wire rope.
9. **WHEN SPREADER BAR ASSEMBLY IS USED** be sure it is properly seated in the saddle of the hook.
10. **AVOID** excessive inching and quick reversals of load.
11. **BE SURE** that the power supply is disconnected before performing maintenance and repair procedure.
12. **DO NOT OPERATE** this unit if it is not functioning properly.
13. **MAINTAIN A MINIMUM OF 4 TURNS OF WIRE ROPE** around the winch drum to prevent the wire rope from pulling off under load.
14. **KEEP WINCHING AREA CLEAR.** Do not allow people to remain in the winching area. Do not stand between the winch and the load.
15. **INSPECT WIRE ROPE FREQUENTLY.** A frayed wire rope with broken strands should be replaced immediately. Never replace the wire rope with rope of any kind or with wire rope other than the type and size specified in the repair parts section of this manual.
16. **USE HEAVY LEATHER GLOVES** when handling the wire rope to eliminate the possibility of cuts or scratches from burrs and slivers from broken strands.
17. **ALLOW WINCH TO COOL DOWN FREQUENTLY (Electric Winch),** as the motor is designed for intermittent duty only. When the metal motor housing is hot to touch, it is time to let the winch cool down
18. **DO NOT OPERATE WINCH WHEN UNDER THE INFLUENCE OF DRUGS, ALCOHOL, OR MEDICATION.**
19. **DO NOT USE WINCH TO HOLD LOADS IN PLACE.** Use other means of securing loads, such as tie down straps.
20. **USE ONLY FACTORY APPROVED, PARTS, SWITCHES, REMOTE CONTROLS AND ACCESSORIES.** Use of non-factory approved components may cause injury or property damage and could void your warranty.
21. **DO NOT MACHINE OR WELD ANY PART OF THE WINCH.** Such alterations may weaken the structural integrity of the winch and could result in personnel injury and void your warranty.
22. **DO NOT OPERATE THIS WINCH OUT DOORS OR IN A CORROSIVE OR EXPLOSIVE ENVIRONMENT.**

SAFETY INSTRUCTIONS

SAFETY DECALS - LOCATION.

If any decals are damaged, replace them immediately!

See next page for explanation of symbols and decals.

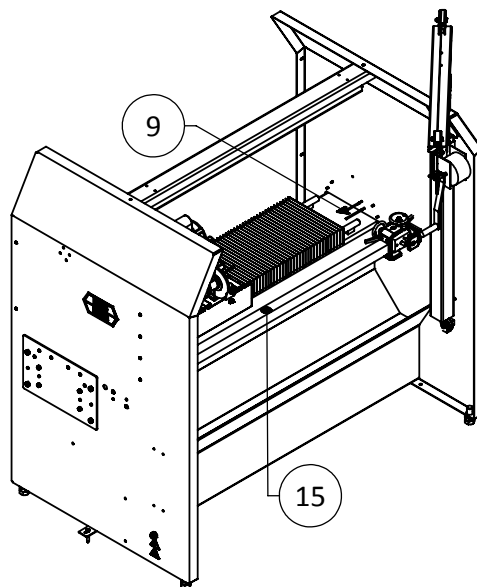
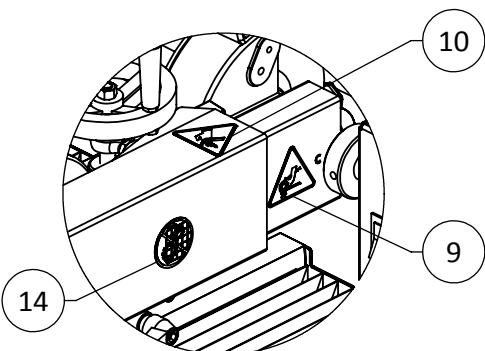
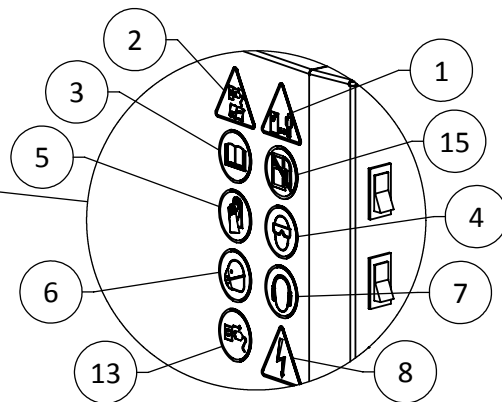
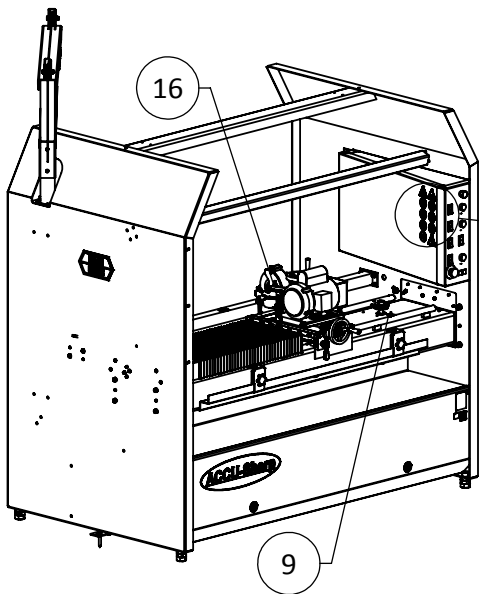
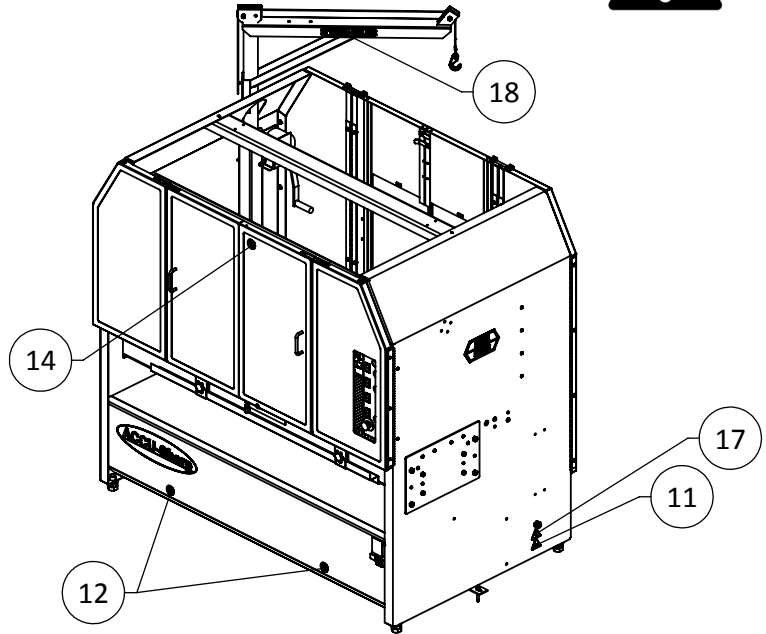
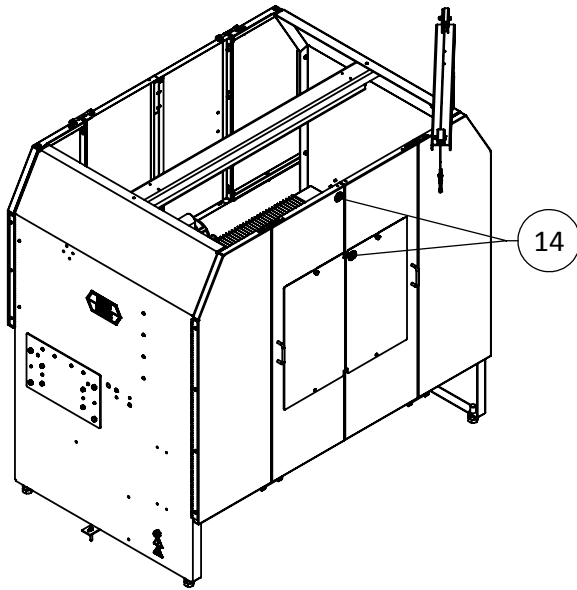



READ AND UNDERSTAND AND LOCATE ALL DECALS ON THIS MACHINE BEFORE OPERATING THIS EQUIPMENT.



- | | | | | | |
|---|---|--|----|--|--|
| 1 |  | Keep visitors at a safe distance away from the equipment. | 10 |  | Sharp object in the vicinity which may cause injury. Keep hands clear of sharp edges! |
| 2 |  | Read Service manual and disconnect power before servicing. | 11 |  | Power cord may be a trip hazard. Secure the power cord in a manner that removes it as a trip hazard. |
| 3 |  | Refer to manual — after installation, read the user's guide carefully before operating. Follow all operating and other instructions carefully. | 12 |  | Use a Fork Lift with a minimum of 48" [122cm] long forks to move this Equipment. Lift only where indicated on the machine. Failure to use proper lifting equipment may result in personal injury or damage to the equipment. |
| 4 |  | WARNING! Use of proper eyewear is mandatory when operating this equipment. | 13 |  | Unplug the machine when servicing or storing for an extended period of time. |
| 5 |  | WARNING! Gloves or other hand protection is required when operating this equipment. | 14 |  | WARNING! Do Not Operate Without Guards and Covers in Place. There are moving parts located behind guard. |
| 6 |  | WARNING! Operators and people in close proximity must wear respirators or have adequate ventilation systems. | 15 |  | WARNING! Keep exposed gasoline or flammables away from the grinder because it operates with a large amount of sparks. |
| 7 |  | WARNING! Hearing protection required when operating this equipment. | 16 |  | Shows the minimum speed [3600 RPM] that the grinding wheel must be rated for to use on this equipment. |
| 8 |  | This is the electrical hazard symbol. It indicates that there are DANGEROUS HIGH VOLTAGES PRESENT inside the enclosure of this product. TO REDUCE THE RISK OF FIRE OR ELECTRIC SHOCK, do not attempt to open the enclosure or gain access to areas where you are not instructed to do so. REFER SERVICING TO QUALIFIED SERVICE PERSONNEL ONLY. | 17 |  | POWER CORD PROTECTION – The power supply cord for this product acts as the main-disconnect. It should be routed or installed in such a manner to protect it from being walked on or pinched. The unit should be powered down completely before connecting or disconnecting the power cable. The power cord should be removed before moving the unit. The power cord must be placed near an easily accessible unobstructed socket outlet. |
| 9 |  | Entanglement Hazard. Keep clear of belt. | 18 |  | WINCH AND BOOM CAPACITY IS A MAXIMUM OF 180Kg OR 400 LBS. Exceeding the capacity may result in personal injury or damage to the equipment. |

GETTING TO KNOW YOUR GRINDER

CONTROL PANEL COMPONENT IDENTIFICATION

Review the following control panel component descriptions before proceeding with the instructions



FIG. 1

SYSTEM START PUSHBUTTON

The green pushbutton is the system start switch. Pushing it will engage the magnetic starter and power the control panel. The magnetic starter will not engage unless the emergency stop pushbutton is pulled out and the grinding motor switch and spin motor switch are turned off.

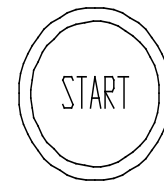

GRIND SELECTOR SWITCH

Variable speed spin Switch must be up to perform spin grinding operations.

Variable Torque Relief Switch must be down to perform relief grinding operations.

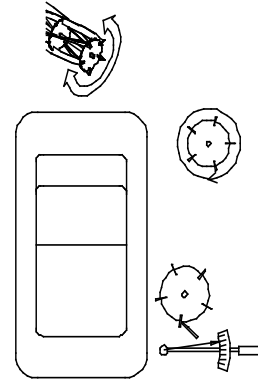

SPIN DRIVE ROTATION SWITCH

Forward / Reverse

This switch reverses the direction of the spin drive motor.
NOTE: *Because the spin drive motor can be flipped, the direction may be opposite of what is shown on the decal.*



THE MOTOR MUST COME TO A COMPLETE STOP BEFORE CHANGING DIRECTIONS. IF THE MOTOR DOES NOT COME TO A COMPLETE STOP, SERIOUS DAMAGE TO THE CONTROL MAY RESULT.

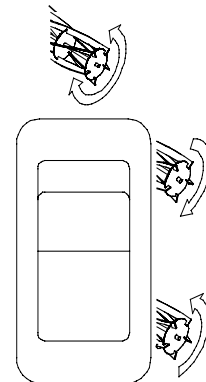

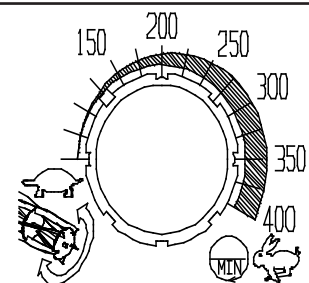

SPIN SPEED POTENTIOMETER DIAL RPM

Adjusts the speed of reel rotation when you have the grind selector switch set at variable speed spin.

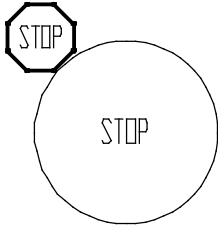
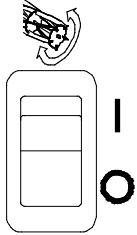
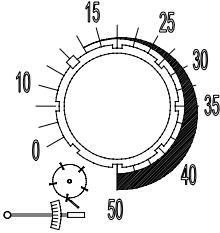

GETTING TO KNOW YOUR GRINDER (Continued)

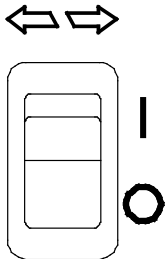
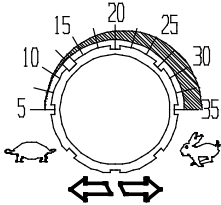
<p>PUSH-PULL EMERGENCY STOP BUTTON Push in to cut all power to the control panel functions. This removes power from all motors, including the grinding motor, traverse motor, spin motor, etc. To restore power, pull up on button and press the Start button.</p>	
<p>SPIN MOTOR SWITCH On / Off</p> <p>Turn the Spin Motor on and off. Guard doors must be shut for the spin drive to operate.</p>	
<p>RELIEF TORQUE DIAL</p> <p>Adjusts the Spin Drive Motor torque (the torque holding the reel blade to the relief finger) when Grind Selector Switch is set at variable Torque Relief.</p>	
<p>GRINDING WHEEL MOTOR SWITCH On / Off</p> <p>Turn the Grinding Wheel Motor on and off. Guard doors must be shut for the grinding motor to operate.</p>	
<p>TRAVERSE MOTOR SWITCH</p> <p>Turns the traverse drive motor ON/OFF.</p>	
<p>TRAVERSE SPEED POTENTIOMETER DIAL - FT / MIN</p> <p>Adjusts the speed of the left & right movement of the Grinding wheel.</p>	

GETTING TO KNOW YOUR GRINDER (Continued)

GETTING TO KNOW YOUR MACHINE

OVERHEAD MOWER CLAMP ASSEMBLY

Each overhead mower clamp assembly consists of two rectangular bar clamps (top and bottom), which also contain adjustable holding fixtures. These clamps will be positioned on the overhead square bar as shown in FIG. 2 and FIG 3. They are designed to lock into place and not move during the grinding procedure. The holding fixtures can be clamped to the front roller or another part of the mowing unit. See Fig 3.

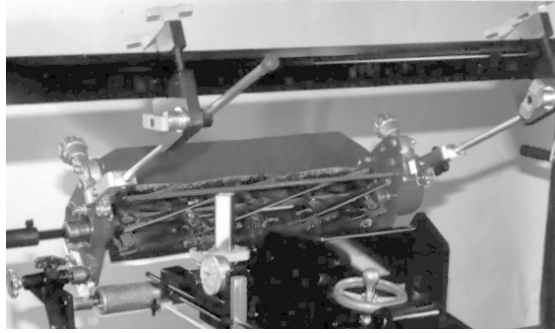

FIG. 2

The flat plate can be bolted directly to the frame. Insert a bolt through one of the holes in the plate and tighten to a hole or thread in the cutting unit frame

ROLLER SUPPORTS

There are two roller supports that are mounted to the square mounting bar so that the "V" faces the back of the machine and the offset can be mounted high as pictured or low. The roller brackets can also face upward with the offset either forward or to the rear. See FIG. 4.

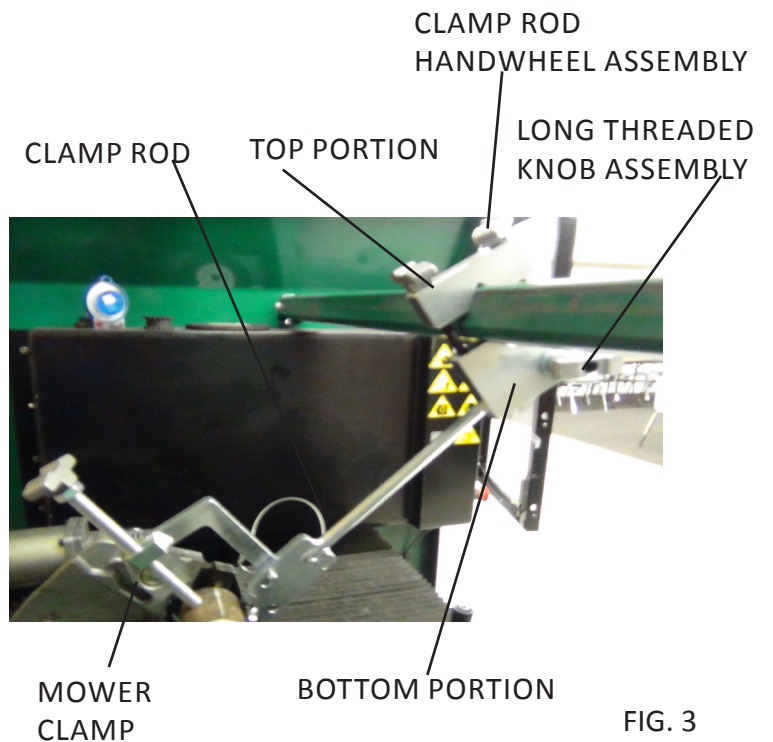

FIG. 3

THE HAND KNOBS ON THE SQUARE BAR MUST BE VERY TIGHT OR THE REEL CAN LOOSEN CAUSING POOR GRIND QUALITY.



FIG. 4

GETTING TO KNOW YOUR GRINDER (Continued)

CENTER MOUNTING BRACKETS

The centers mounting brackets consist of a stationary center bracket and an adjustable center bracket. The stationary bracket will normally be used on the right hand side of the mounting bar when facing the reel loading position. See FIG. 5. These centering fixtures are used primarily on greens mowers and the **OPTIONAL** Bedknife Attach Kit 6000555.



FIG. 5

OPTIONAL PULL GANG BRACKETS

The **OPTIONAL** Pull Gang Reel Mount Kit 18574 consists of a lower mounting bracket that fits over the square tooling mounting bar and two threaded locking screws. Attached to this is the upper "V" bracket that cradle the reel hub when in position. There are three vertical adjustments on this fixture. The Fixture will normally be used in the upper hole position. See FIG. 6.



FIG. 6

These brackets can be mounted on the square mounting bar with offset either forward or backwards, but the normal position will be with the "V" centered over the bar or with the offset facing the back of the machine. The hold-down swing arm has an upper and lower mounting position depending on mower hub size.

The rear roller of the pull gang mowing unit attaches to the roller supports as shown in FIG. 7.

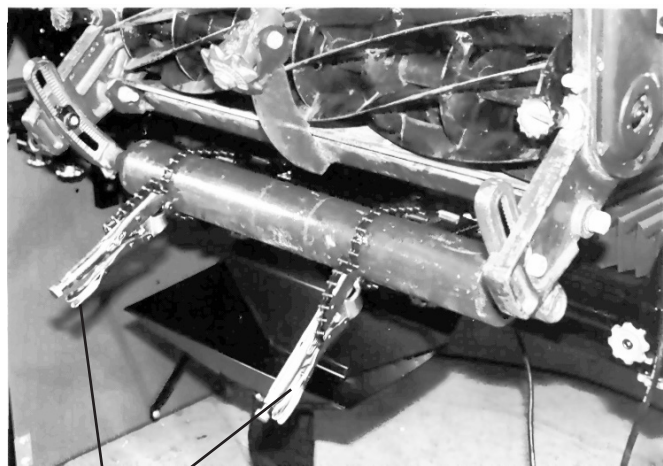

FIG. 7

WISE-GRIP CHAIN CLAMPS

GETTING TO KNOW YOUR GRINDER (Continued)

TRAVERSE ACTUATOR RELEASE

The actuator that drives the grinding carriage left and right can be released to allow manual movement of the grinding carriage. The traverse engagement lever is located at the front of the carriage to the left of the infeed handwheel. See FIG. 8 and FIG. 9. Rotate the release arm up to release the belt and rotate the release arm down to engage the belt.

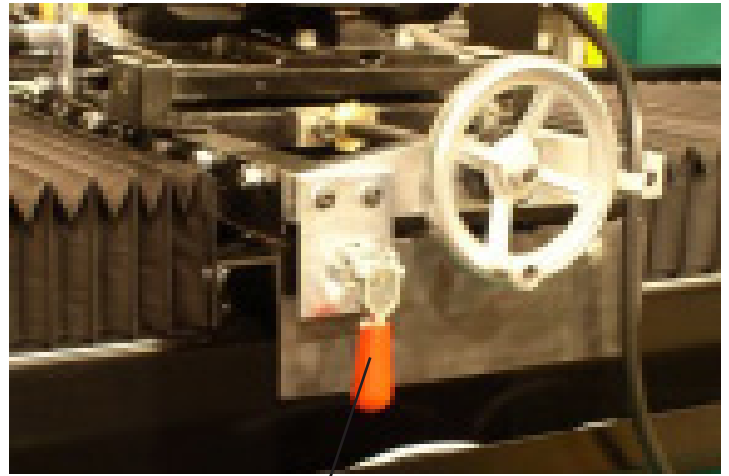

TRAVERSE ENGAGEMENT
LEVER (ENGAGED)

FIG. 8

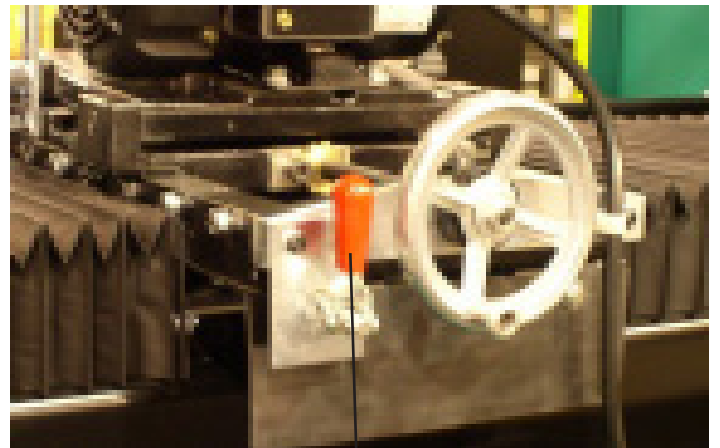

TRAVERSE ENGAGEMENT
LEVER (RELEASED)

FIG. 9

PROXIMITY SENSORS

This grinder is equipped with proximity sensors to limit the travel of the grinding head. When activated the proximity sensors will change the direction of the grinding head. Adjust the position by loosening the star knob and sliding them along the rail and retighten. See FIG. 10.

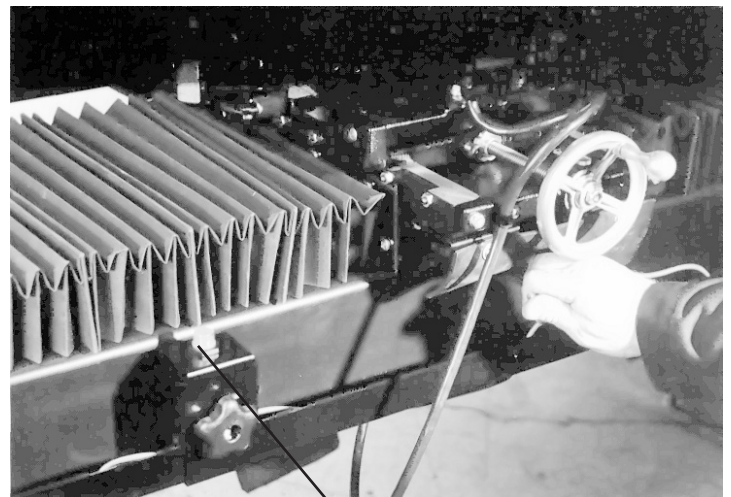

PROXIMITY SENSOR

FIG. 10

GETTING TO KNOW YOUR GRINDER (Continued)

GRINDING WHEEL AND GUARD FOR SPIN GRINDING

Spin grinding requires a 1.00" wide [25.4 mm] grinding wheel and the flat grinding wheel guard. See FIG. 11.

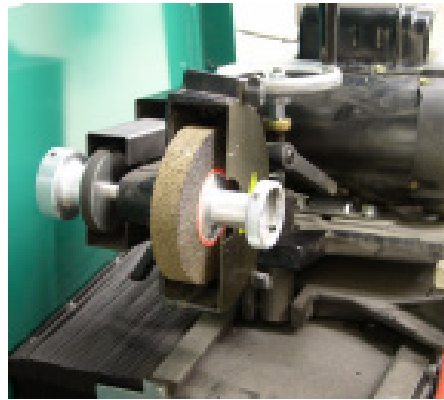

FIG. 11

GRINDING WHEEL AND FINGER - GUARD ASSEMBLY FOR RELIEF GRINDING

Relief grinding requires a 3/8" .375" [9.5 mm] grinding wheel. Use the wheel guard with the fixed relief finger and the moveable index finger. See FIG. 12.

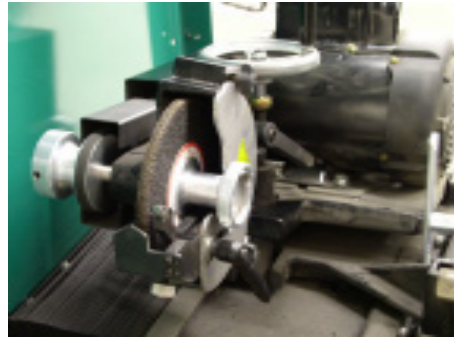

FIG. 12

RELIEF GRINDING FINGER ADJUSTMENTS

The relief Index Finger Assembly has three adjustments:

1. The position of the index pin can be adjusted by loosening the locking setscrew. The height of the finger may need to be raised to catch the next blade on small diameter reels or it may need to be lowered to avoid interference with the reel spider. See FIG. 13.

INDEX PIN

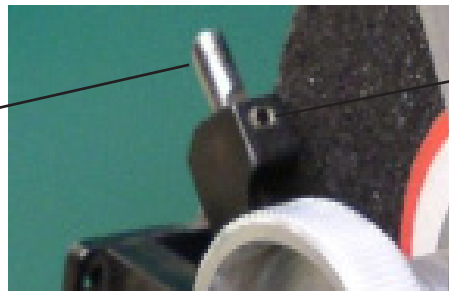

LOCKING SETSCREW

FIG. 13

2. Use the travel limit knob to adjust the stop position of the moveable finger. The moveable finger stop needs to be adjusted so that the reel blade makes a smooth transition from the index pin onto the fixed finger. See FIG. 14.

FIXED FINGER



MOVEABLE FINGER

TRAVEL LIMIT KNOB

FIG. 14



WHEN GRINDING, THE REEL BLADE SHOULD BE SUPPORTED BY THE FIXED FINGER NOT THE MOVEABLE INDEXING FINGER. FAILURE TO ADJUST THE STOP CORRECTLY WILL RESULT IN GRINDING OR INDEXING ISSUES.

3. Use the lock handle on the side of the wheel guard to adjust the gap between the fixed finger and the grinding wheel. See FIG 15. To reposition, loosen the lock handle and slide the finger toward or away from the grinding wheel. The distance between the grinding wheel and fixed finger should be between .06" [1.5mm] and .18" [4.6mm] depending on the amount of existing relief on the reel. See FIG. 15.

LOCK HANDLE



FIG. 15

GETTING TO KNOW YOUR GRINDER (Continued)

DIAL INDICATOR SET UP FIXTURE

The dial indicator set up fixture is used to align the reel to the grinding head prior to grinding.

The dial indicator set up fixture is designed to be quickly mounted into position and/or quickly removed.

The fixture is mounted to the front left corner of the grinding head assembly as shown in FIG. 16.

When the fixture is not in use, it is quickly removed and can be stored on the tool tray.

ATTACH FIXTURE WITH
THIS SCREW KNOB

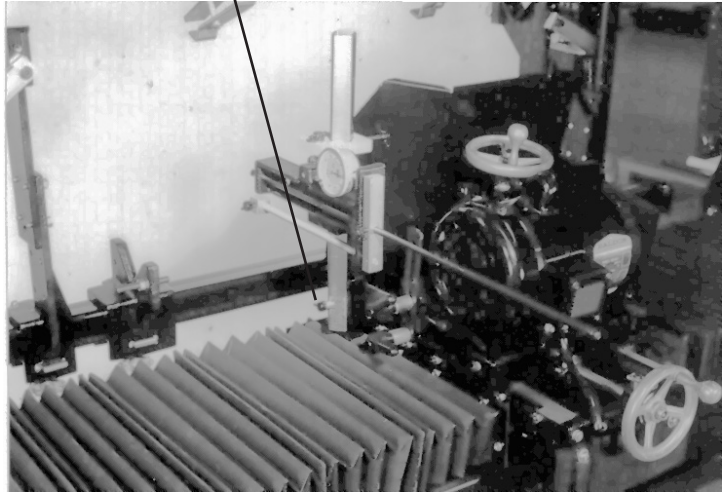

FIG. 16

OPERATING INSTRUCTIONS

PREPARE MOWER FOR SHARPENING

Preparation of the mowing unit prior to sharpening.

It is recommended that the mowing unit to be sharpened is thoroughly cleaned. Remove wheels and bed bar, if possible from the reel. **For best results the Bedknife should be sharpened whenever the reel is sharpened.** Inspect, adjust and/or replace any worn or damaged bearings. Make sure the reel bearings are adjusted properly so that the reel turns easily by hand.

REELS WITH EXCESS TENSION ON THE BEARINGS WILL BE EXTREMELY DIFFICULT TO SPIN GRIND AND COULD CAUSE DAMAGE TO THE REEL OR THE SPIN DRIVE MECHANISM ON YOUR GRINDER. NO MORE THAN 25 IN LBS. MAXIMUM TORQUE LOAD TO ROTATE THE REEL IS ALLOWED OR DAMAGE TO THE SPIN DRIVE COULD OCCUR.

REELS GROUND WITH BEARINGS WHICH HAVE WEAR AND/OR FREE PLAY WILL NOT HOLD DIAMETER, CYLINDRICAL SHAPE, OR STRAIGHTNESS SPECIFICATIONS.

INITIAL SET UP OF REEL SUPPORTS

A. The preferred method of mounting fairway units and greens mower units is to set the rear roller on the roller supports facing up with the offset toward the back. To secure the cutting unit, wrap the chain clamp around the roller and the tooling bar. See FIG. 18.

B. With greens mowers, you may use the centers mounting brackets. See FIG. 19.

C. On ground drive fairway mowers with exposed hubs, you should use the **OPTIONAL** Pull Gang Reel Mount Kit 18574. Normally the upper brackets will be positioned in the top two holes of the lower supports with the offset "V" facing toward rear of the machine. See FIG. 20.

NOTE: The position of the "V" bracket to the lower support can be adjusted to any of the three different height settings and two offset positions to accommodate the many different reels available.

FIRMLY TIGHTEN ALL LOCKING KNOBS BEFORE GRINDING. ANY LOOSE KNOBS WILL ADVERSELY AFFECT THE GRIND QUALITY.

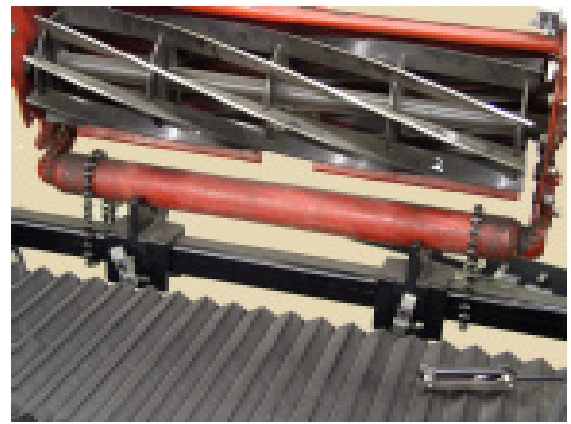

FIG. 18



CENTERING PIN

CENTERING BRACKET

FIG. 19

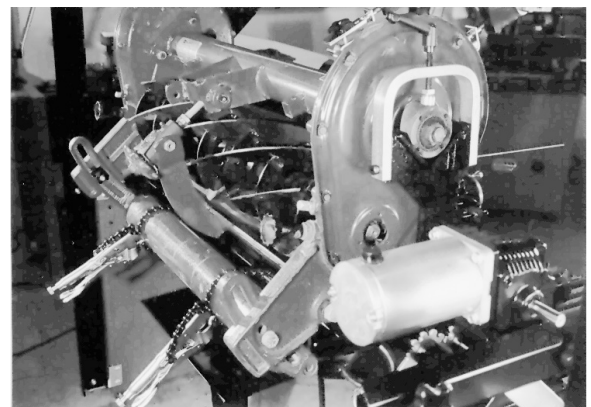

FIG. 20

OPERATING INSTRUCTIONS (Continued)

INITIAL SET UP OF SUPPORTS (CONTINUED)

INITIAL SET UP OF ROLLER SUPPORTS

The roller support brackets should be placed facing up with the V ribs 1 to 2" narrower than the width of the rear roller with the offset either forward or back, depending on mowing unit requirements.

NOTE: Tighten the side locking knob first so the bracket is forced against the mounting bar. Then tighten the bottom bracket. See FIG. 21.

CENTERS BRACKET SET UP

When mounting greens mower mowing units, centers may be used to hold the mower unit. See FIG. 22. To mount, measure the outside distance of the mower frame. Using the center point of the square mounting bar position the fixed centering bracket $\frac{1}{2}$ that distance on the left side and securely fasten. Then place the adjustable centering bracket that distance plus $\frac{1}{4}$ " on the right side of the mounting bar and loosely fasten. It may be necessary to move this bracket when lifting reel into place even though it can be adjusted. The adjusting cone should be retracted as far as possible as it will be easier to secure reels when in place.

OPTIONAL PULL GANG BRACKET SET UP

On ground drive mowing units with exposed hubs you will be using the **OPTIONAL** Pull Gang Reel Mount Kit 18574, measure the distance from the outside of the hubs and subtract one inch. Determine the middle of the square mounting bar, by use of the winch cable. Then place a "V" bracket $\frac{1}{2}$ that distance on the left side of the mounting bar and securely fasten using both locking knobs.

Now place a "V" bracket on the right side of the mounting bar the same distance from the center point, but loosely attach as it might have to be moved when reel is lifted into place. The roller support brackets should be placed 6 to 8" inside the reel supports with the "V" facing the back of the machine and securely fastened with both locking knobs. The "V's" have an offset so they can be installed high or low depending on the reel. See FIG. 23.

FIRMLY TIGHTEN ALL LOCKING KNOBS BEFORE GRINDING. ANY LOOSENESS WILL ADVERSELY AFFECT GRINDING QUALITY.



FIG. 21



FIG. 22



FIG. 23

OPERATING INSTRUCTIONS (Continued)

LIFTING MOWING UNIT INTO POSITION WHEN USING ROLLER SUPPORTS

Position the mowing unit behind the grinder on the floor so the front of the mower faces the front of the machine. Hook the reel elevator spreader bar onto the mowing unit. The hooks on the bar should be spaced evenly along the mowing unit, so they do not slip or slide as it is being raised. See FIG. 24.

⚠ WARNING

THE OPERATOR SHOULD BE POSITIONED AWAY FROM THE REEL. GUIDE REEL AT ARMS LENGTH. STAND WELL CLEAR OF THE CUTTING UNIT WHEN WINCHING INTO POSITION.

Slowly raise the mowing unit by cranking the winch handle with the right hand and steadying the reel with the left hand. Your left arm should be extended during the lifting operation. This will help keep the operator from under the mower.

⚠ WARNING

KEEP A HAND ON THE WINCH HANDLE UNTIL THE CUTTING UNIT IS POSITIONED AND RESTING ON THE SUPPORTS OR THE GROUND. NEVER LEAVE A CUTTING UNIT SUSPENDED IN THE AIR.

Slowly move the reel into position and carefully lower the cutting unit onto the roller supports. Firmly tighten both locking knobs on the roller supports. Verify that the spin drive can be connected to the reel in this position. Once the reel roller is positioned correctly in the roller supports, wrap the chain vise clamp around the roller and the square tubing tooling bar. Firmly tighten and repeat this step with the other chain vise clamp.

LIFTING MOWING UNIT INTO POSITION WHEN USING CENTER BRACKETS

Position the mowing unit as described above using roller supports. Slowly raise the mowing unit into position and insert the fixed centering pin into a predetermined hole in the mowing unit frame. While holding the mowing unit firmly against the fixed centering pin, raise or lower the mowing unit so the adjustable centering bracket can be moved and the cone inserted in a corresponding hole in the opposite side of mowing unit frame. Now very firmly tighten both locking knobs on the adjustable bracket and then tighten the adjustable centering pin locking knob. See FIG. 25.

Verify that the spin drive unit can be connected to the reel in this position.



FIG. 24

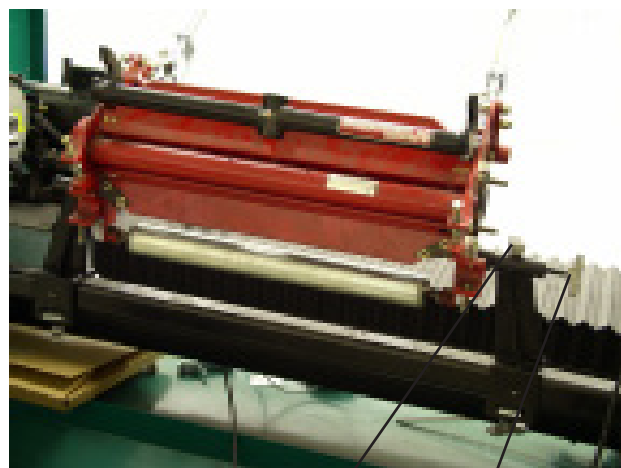

LOCK KNOB

FIG. 25

ADJUSTABLE CENTER KNOB

FIRMLY TIGHTEN ALL LOCKING KNOBS BEFORE GRINDING. ANY LOOSE KNOBS WILL ADVERSELY AFFECT THE GRIND QUALITY.

THE ADJUSTABLE CENTER MUST BE FIRMLY TIGHTENED INTO THE REEL, BUT EXCESSIVE FORCE CAN DISTORT THE REEL FRAME CAUSING BINDING AND POOR QUALITY.

SPREADER BAR ASSEMBLY

In most cases, it is recommended to leave the spreader bar and chains hooked up to the mowing unit as an added safety precaution. The cable should be winch tight to insure the chain, hook and spreader bar will not become engaged with the reel during sharpening.

REMOVING SPREADER BAR FROM REEL

If the hooks will not clear the spinning reel, then remove the spreader bar and hooks from the mowing unit. Place hooks over the top channel on the boom and crank up excessive slack.

OPERATING INSTRUCTIONS (Continued)

LIFTING MOWING UNIT INTO POSITION WHEN USING THE OPTIONAL PULL GANG MOUNTING BRACKETS

Position the mowing unit as described on the previous page using roller supports. See FIG. 26

Slowly raise the mowing unit. When the hub of the reel has been raised above the top of the "V" bracket slowly position the left side of the reel into the bracket and lower until you make contact with the bracket.

Now reposition the right "V" bracket if necessary and lower the reel completely into both brackets. Securely tighten the right bracket using both locking knobs.

NOTE: On reels that have a square or hexagon shaped hub make sure that the surface of the hub is against the flat machined surface of the "V" bracket.

When the reel is correctly positioned in the V-bracket, swing the clamping handles into place and firmly lock in place. See FIG. 27.

NOTE: The clamping handles have two mounting positions for large and small hubs.

NOTE: Unless the elevator hooks interfere with the reels ability to spin, leave the elevator hooks and spreader connected to the reel with slight tension on the wire cable.



FIG. 26

CLAMP HANDLE

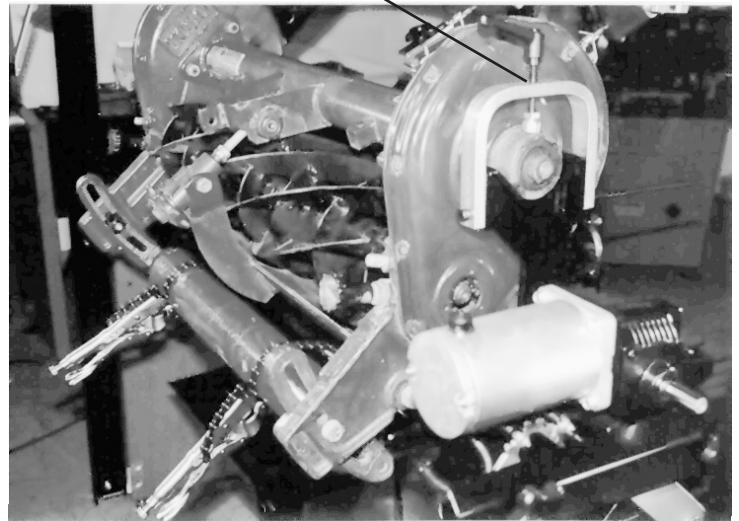

FIG. 27

OPERATING INSTRUCTIONS (Continued)

LIFTING MOWING UNIT INTO POSITION WHEN USING THE OPTIONAL PULL GANG MOUNTING BRACKETS (CONTINUED)

There are two (2) roller supports that are mounted to the square mounting bar so that the "V" faces the back of the machine as pictured in FIG. 28A.

The pull gang brackets come with four (4) long set screws which should be installed on the roller supports. The set screws are used to hold the extender plates when it is necessary to move the mower roller back further to help expose the drive nut in the reel. These set screws will also be used to attach the chain vise clamps when reels are in position.

Position the roller supports so the reel roller is centered on the two (2) supports and firmly lock in place.

NOTE: On some reels the "V" grooves of the roller supports will be positioned on top of the support bar. This application is used primarily for fairway and greens mowers. See FIG. 28B.

If the mowing unit back needs to be positioned further back, pull the mowing unit back out of the way and slide the extender plate onto both long socket head set screws and tighten down with 3/8-16 nuts and 3/8 lock washers. See FIG. 28C.

MAKE SURE THAT THE ELEVATOR CABLE IS ATTACHED TO THE REEL AND THAT SOME TENSION IS ON CABLE BEFORE PULLING THE REEL BACK.

When the reel roller is positioned correctly in the roller brace, wrap one of the chain vise clamps around the roller, and around the stud on the roller brace. Firmly tighten and repeat this step with the other chain vise clamp around the other roller brace. See FIG. 29.

FIRMLY TIGHTEN ALL LOCKING KNOBS BEFORE GRINDING. ANY LOOSE KNOBS WILL ADVERSELY AFFECT GRINDING QUALITY.

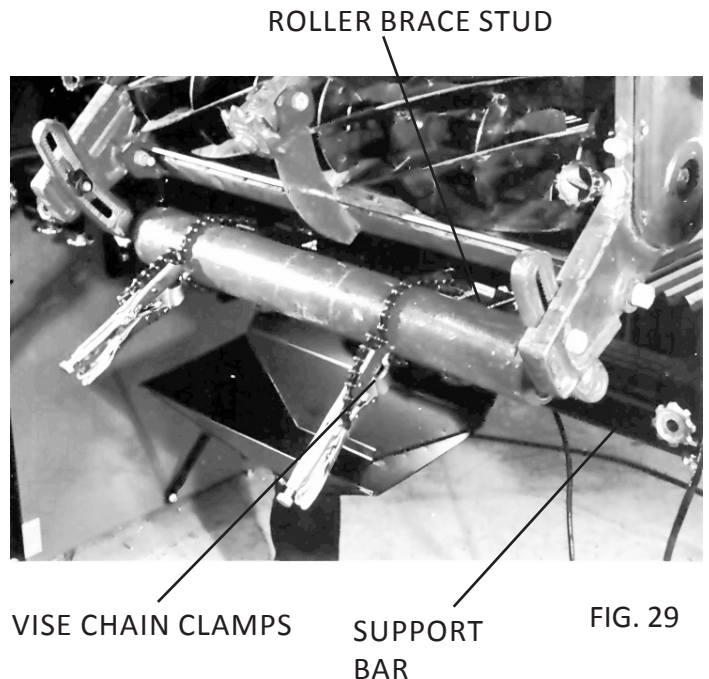
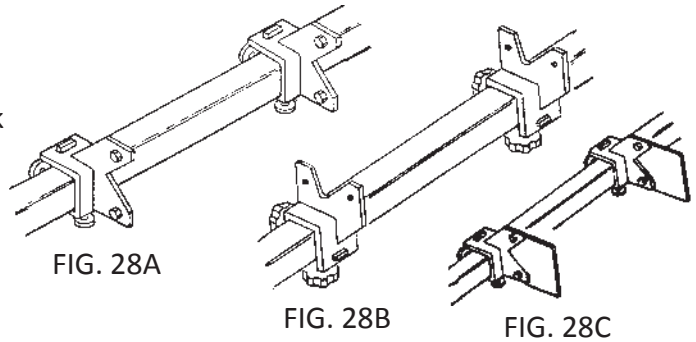

OPERATING INSTRUCTIONS (Continued)

ATTACHING THE OVERHEAD CLAMPING ARMS

Your grinder is supplied with two clamp rods and two mower clamps.

Determine which clamp arms to use in your grinding application. You have two choices; First, the large mower clamps which are primarily attached to the front rollers. Second, attach the clamp rods with the flat plate directly to the mowing unit using the hole on the end of the clamp rod attached to a stud or bolt on the mowing unit frame.

Loosen the two (2) screw handles on each overhead clamp and move them to where the overhead clamp rods can be attached to the mowing unit. Tighten the mower clamps to the mower, then securely tighten the two (2) locking handles on each overhead clamp. See FIG. 30.

The overhead clamps can be mounted with the clamping rod above the tubing cross bar or they can be mounted with the clamp rod under the tubing cross bar as shown in FIG. 30. It is recommended to mount them under the tubing cross bar whenever possible.

Before tightening the overhead clamps you must correctly position the mowing unit. When using the roller supports or the centers, you can pivot the cutting unit with the overhead clamps. With the relief grinding wheel and the relief guard with fingers installed, you must pivot the cutting unit so you have clearance of the relief finger to the frame, clearance of the next blade to be relieved to the grinding wheel and clearance of the grinding wheel to the front roller.

DO NOT TIGHTEN THE LEFT HAND SLIDE ROD CLAMP WHERE RODS ARE INSERTED INTO THE LOWER PART OF THE CLAMP UNTIL REEL HAS BEEN ALIGNED SEE FIG. 40.

FIRMLY TIGHTEN ALL LOCKING KNOBS BEFORE GRINDING. ANY LOOSENESS WILL ADVERSELY AFFECT GRINDING QUALITY.

OVERHEAD CLAMPS

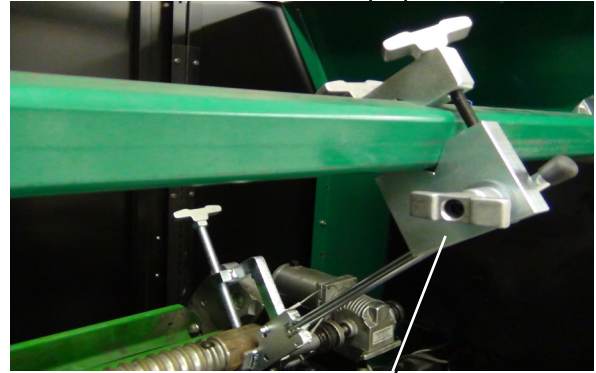

FIG. 30

SLIDE BAR CLAMP

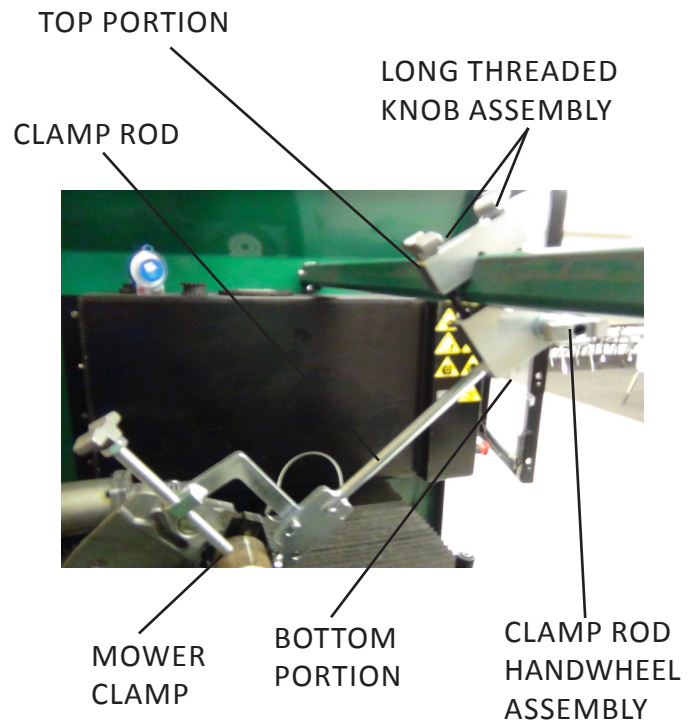

FIG. 31



FIG. 32

OPERATING INSTRUCTIONS (Continued)

DIAL INDICATOR SET UP FIXTURE

The dial indicator set up fixture is designed to be quickly mounted into position and/or quickly removed.

The fixture is mounted to the front left corner of the grinding head assembly as shown in FIG. 33.

When the fixture is not in use, it is quickly removed and can be stored on the tool tray.

REEL ALIGNMENT USING THE DIAL INDICATOR SET UP GAUGE ASSEMBLY

A. Mount the set up gauge into position on the left front side of the grinding head assembly. The gauge assembly can be set on the roll pin on the grinding head slide base. This will line up the tee knob with the threaded hole in the casting for an easy install. See FIG. 33.

B. The left side overhead clamp rod adjusting knob (See FIG. 34.) must be loose to allow the mower assembly which is mounted on the mower support bar to move freely when doing horizontal and vertical adjustments.

The overhead clamp rods will generally be used as described below:

1. If the mowing unit is mounted with the ground roller clamped to the roller supports with the chain vice clamps, because the geometry does not offer enough stability or rigidity, the overhead clamp rod on the fixed end (right side in the operator's position) should be kept tight.
2. If the mowing unit is mounted in centers and only being stabilized by the overhead clamp rods, then the clamp rod on the fixed end must be kept tight.
3. If the mowing unit is clamped in the **OPTIONAL** Pull Gang Reel Mount Kit 18574 V-brackets and the ground roller is clamped with chain vice clamps, then both overhead clamp rod adjusting knobs can be loose.

C. Loosen the two locking knobs on the cross slide assembly on the left side of the square mounting bar so that it can be adjusted in both the vertical and horizontal plane. See FIG. 35.

ATTACH FIXTURE WITH THIS SCREW KNOB

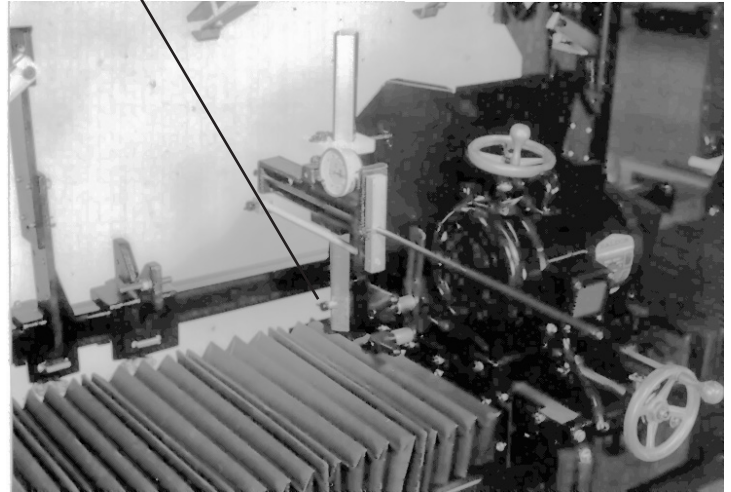

OVERHEAD CLAMP ROD ADJUSTING KNOB

FIG. 33

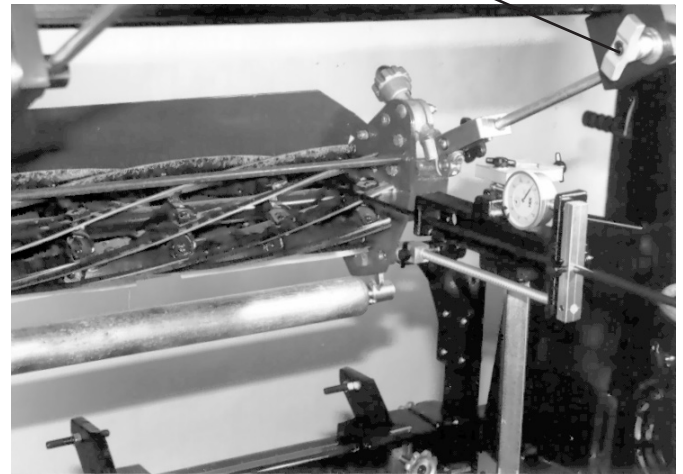

HORIZONTAL LOCKING KNOB

VERTICAL ADJUSTING SCREW

FIG. 34

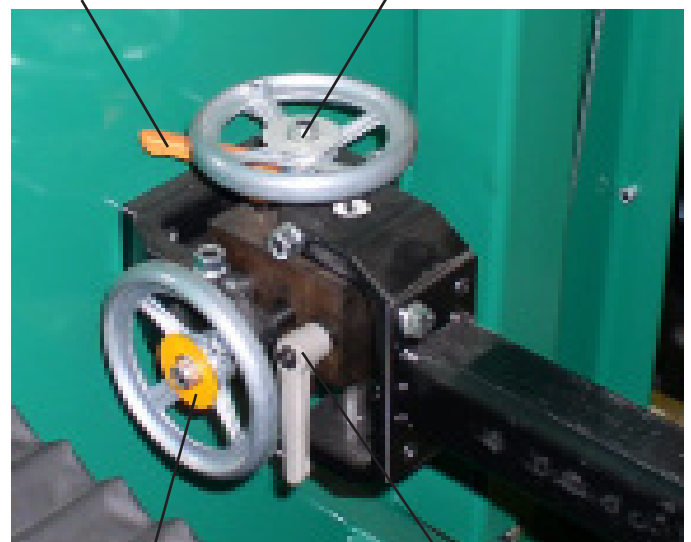

HORIZONTAL ADJUSTING SCREW

VERTICAL LOCKING KNOB

FIG. 35

OPERATING INSTRUCTIONS (Continued)

ALIGNING REELS IN THE VERTICAL PARALLELISM PLANE

- A. Move the grinding head assembly until the set up fixture is approximately 1" from the right side of the reel. Lock the Knob A within approximately 1/8" .125" (3MM) of center shaft of the reel. See FIG. 38.
- B. Raise the indicator slide casting on the vertical support so that the indicator rod can be extended over the center shaft of the reel. See FIG.36 and 37.
- C. Lower the indicator slide by turning the vertical fine adjustment Knob B until the alignment rod lightly touches the top or bottom of the reel center shaft. See FIG. 40.
- D. Pull rod back and lock Knob C. See FIG. 38. Traverse to the other side of reel, same distance from end. Loosen Knob C and extend alignment rod. See FIG. 39.
- E. If the left side is lower than the right, turn the vertical adjusting grey handwheel in the cross slide assembly clockwise raising the mounting bar and the reel until the center shaft of the reel lightly touches the extended indicator rod. See FIG. 36.

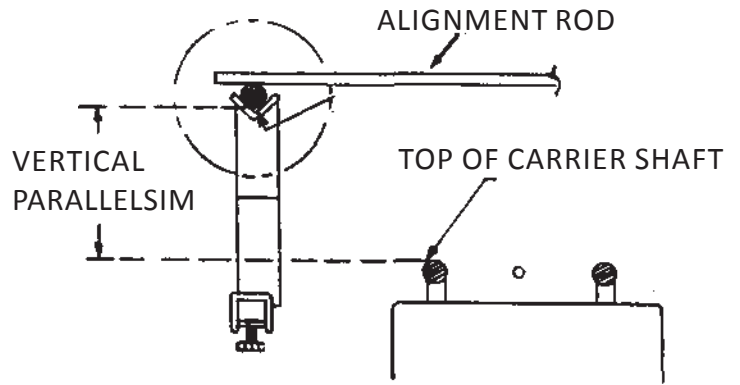

FIG. 36

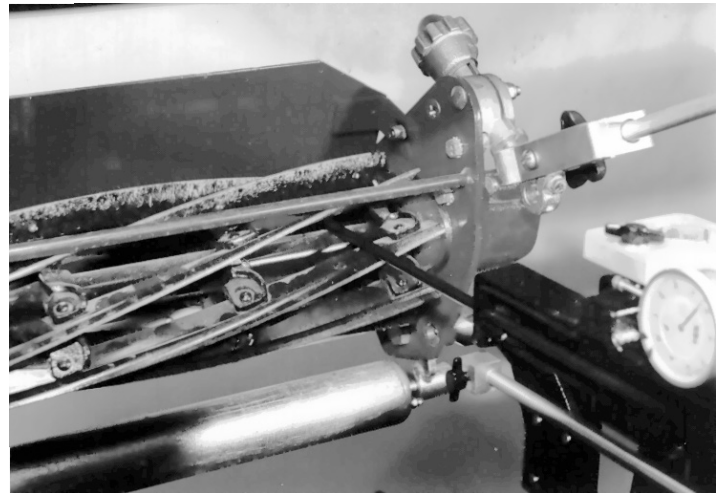

FIG. 37

KNOB C KNOB B KNOB A

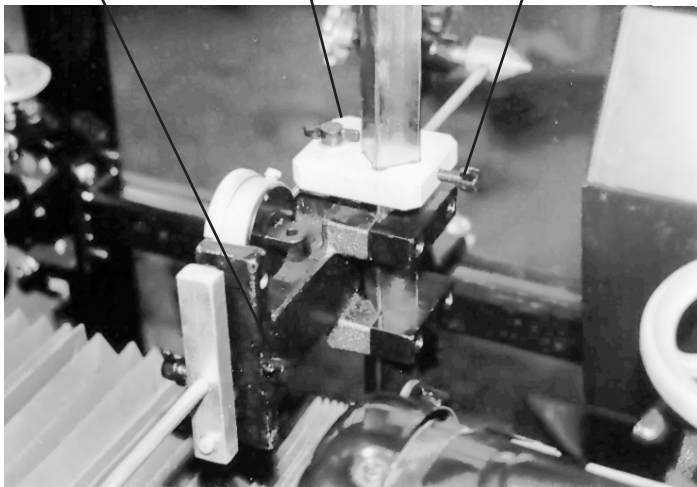
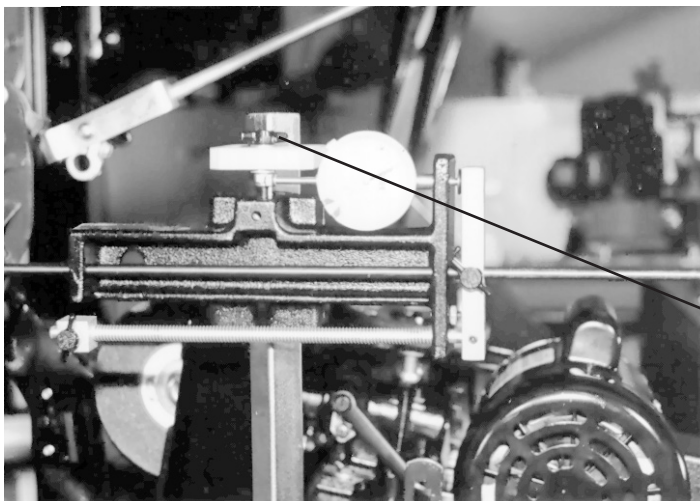

FIG. 38



FIG. 39



KNOB B

FIG. 40

OPERATING INSTRUCTIONS (Continued)

VERTICAL ALIGNMENT (CONTINUED)

F. Take note of the vertical adjustment handwheel (grey) so you know from where you are starting. See FIG.42. Now turn the vertical adjusting grey handwheel an additional 1/2 revolution. This 1/2 revolution is to compensate for the fact that as you adjust the left side, the right side is also moving at a proportioned amount. This should almost align your reel in the vertical parallelism plane. See FIG. 42.

G. Move the alignment fixture back to the right hand side of the reel and readjust the alignment rod so that it lightly touches the top or bottom of reel center shaft.

H. Move it back to the left side to make sure the reel is in correct vertical position. If not, use the vertical adjustment handwheel (grey) to move the reel up or down so that it just touches alignment rod on both sides. When it does, retest the right and left sides until they are the same.

I. If the left side of the reel is found to be higher than the right, lower the mounting bar and reel until alignment rod lightly touches the top or bottom of the reel center shaft and then turn the vertical adjusting handwheel (grey) an additional 1/2 revolution. This 1/2 revolution is to compensate for the fact that as you adjust the left side, the right side is also moving at a proportioned amount. This should line the reel up accurately on both sides. Then continue with procedures found in "G" and "H" above.

J. Lock the grey vertical adjusting screw locking knob. See FIG. 42.

NOTE: *This alignment is not as critical as the horizontal plane, but care should be taken on all reel set ups. The accuracy is to be within approximately .010".*

NOTE: *The pivot end of the support bar is pinned to the frame permanently. The adjustable end can be adjusted independently both vertically and horizontally.*

! **CAREFULLY REVIEW THE CORRECT IDENTIFICATION OF THE COLORED LOCKING KNOBS IN FIG.49 MAKE CERTAIN YOU ARE LOCKING AND UNLOCKING THE CORRECT KNOBS.**

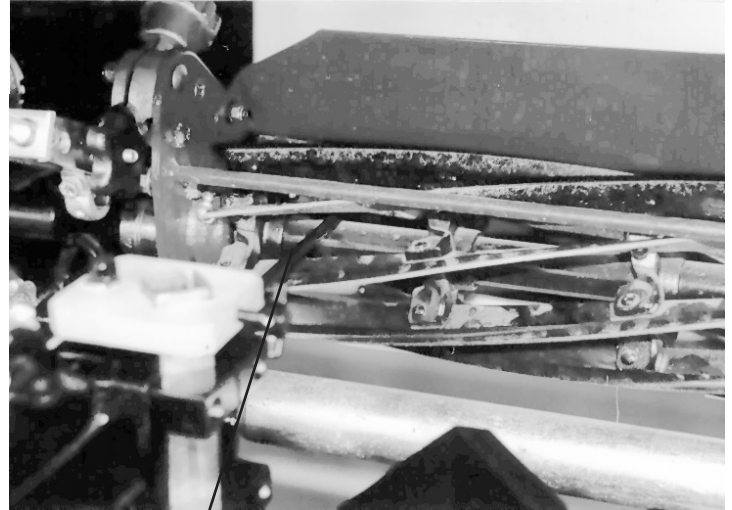

ALIGNMENT ROD

FIG. 41

ORANGE HORIZONTAL LOCKING KNOB VERTICAL GREY ADJUSTING HANDWHEEL

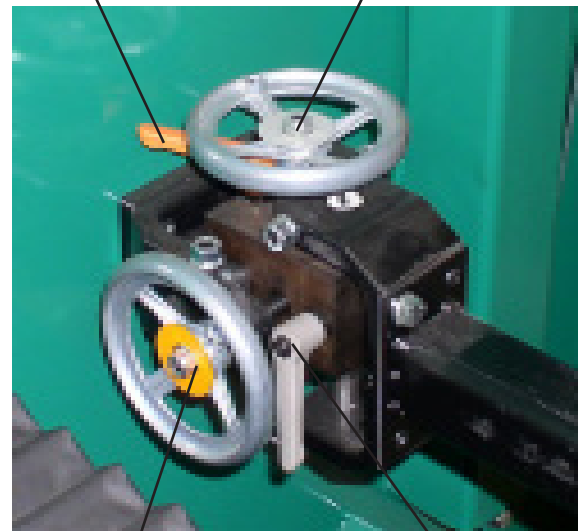

HORIZONTAL ORANGE ADJUSTING HANDWHEEL

GREY VERTICAL LOCKING KNOB

FIG. 42

OPERATING INSTRUCTIONS (Continued)

ALIGNING REELS IN THE HORIZONTAL PARALLELISM

THIS IS A CRITICAL SET UP AND CARE SHOULD BE TAKEN WHEN MAKING THESE ADJUSTMENTS. IF REEL IS OUT OF POSITION IN THE HORIZONTAL PLANE, IT WILL BE GROUND CONE SHAPED. SEE FIG. 49.

A. Move set up gauge on the right hand side of reel approximately 1" from the end. See FIG. 44.

B. Lower the indicator slide casting on the vertical support so the indicator rod can make contact with the center of the reel shaft within approximately 1/16" .062" (1.5 MM) and lock Knob A. See FIG. 38. Center shaft should be clean and free of rust where rod makes contact. Fine adjust using Knob B until at the center of the center shaft of the reel. See FIG. 40.

C. Loosen Knob D on the indicator stop bar. Holding the indicator rod firmly against the reel shaft, move the indicator stop bar back, until no contact is made with the indicator rod plunger. Now move indicator stop bar forward until contact is made and then an additional 1/2". This will set the plunger at about its midpoint and allow it to move in both directions. See FIG. 46.

D. Now set the outer dial indicator to the "0" position. Read and note the position of the smaller (.100) dial. You must know this reading when setting up the other side. Pull back and lock with Knob C. See FIG. 38.

E. Move the alignment gauge to the left side of the reel carefully retracting the indicator rod so as not to damage or change setting. Set indicator rod on the same position on the reel as you had on the right side, that is 1" from the end and centered on the shaft See FIG. 45. Now read the dial indicator to determine the distance the reel is out of position.

NOTE: Because the set up gauge is mounted to the carriage, you can unlock the actuator drive system and traverse manually from end to end.

When you pull the indicator rod back, there is knob ("C") to snug up so you do not have to hold the rod in the back position. See FIG. 38.

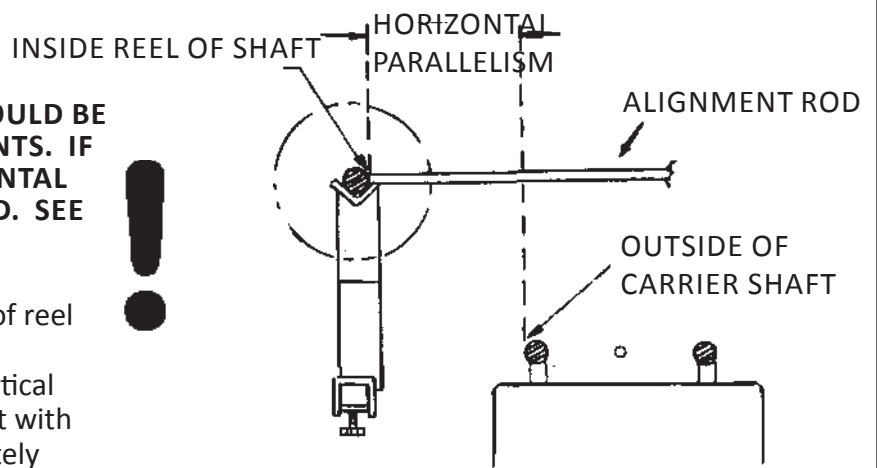

FIG. 43



FIG. 44

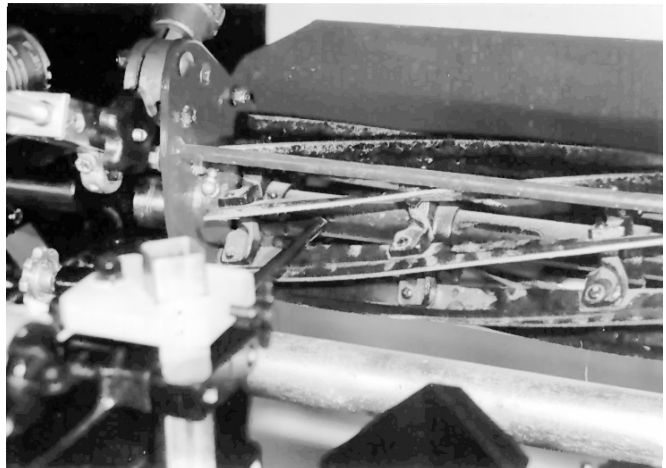

FIG. 45

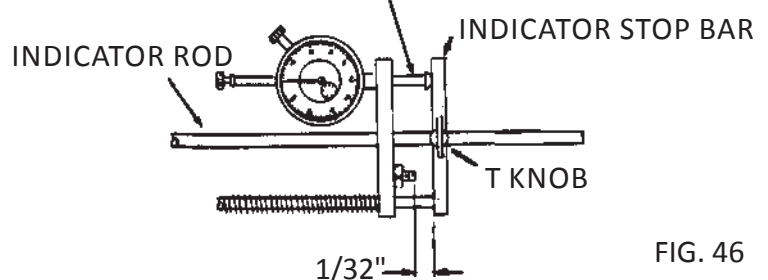

FIG. 46

OPERATING INSTRUCTIONS (Continued)

ALIGNING REELS IN THE HORIZONTAL PARALLELISM (CONTINUED)

F. To adjust reel position first determine the direction the reel has to move for alignment. The direction that the reel will have to be moved can be determined by pulling back on the dial indicator stop bar and if the dial moves back to the "0" position you will have to move the reel towards you. If that cannot be done the reel will have to be moved away from you.

There are two adjusting steps for final positioning of the reel as follows:

1. With the reel set gauge still in the left hand side of the reel, turn the orange horizontal adjusting handwheel (FIG. 47) in the direction required until you match the initial indicator reading on the right hand reel position. See FIG. 44.
2. Now continue to turn the handwheel to travel farther by the full amount already traveled.

EXAMPLE: *If the reel center shaft is off .085 right to left, turn the handwheel from .085 to zero and then continue to turn until it reads .085 additional on the other side of zero.*

The reason for this is that the square mounting bar pivots on one end and is adjusted on the opposite end. Anytime the adjusting end is moved to change the left side dimension, the right side dimension is also changing at a ratio to the left side. By over compensating at the adjusting end you will compensate for this movement and get the reel aligned much faster.

G. Now move the set up stand back to the right side of the reel. Set indicator rod on the same spot you used the first time and reset large dial on "0". Make sure you read the setting on the small scale and note. Then proceed with paragraph "E" & "F" again. This should give final adjustment. When you have done this procedure a few times you will find this procedure will become very easy.

IT IS ESSENTIAL THAT CARE IS TAKEN WHEN SETTING THE REEL UP IN THE HORIZONTAL POSITIONS IN ORDER TO GRIND IT INTO A CYLINDER SHAPE. ANY MISALIGNMENT WILL CAUSE YOU TO GRIND INTO A CONE. SEE FIG. 56.

H. When the horizontal parallelism has been adjusted to within .003" (.076 MM) end to end, tighten the horizontal adjustment locking handle. See FIG. 47 and both overhead clamp adjusting knobs. See FIG. 48. When tightening the knob it is very important that you have the dial indicator located at that side of the reel and watch it as you tighten. It must not move in the tightening process. After both knobs are tight, recheck alignment.

ORANGE HORIZONTAL LOCKING KNOB
VERTICAL GREY ADJUSTING HANDWHEEL

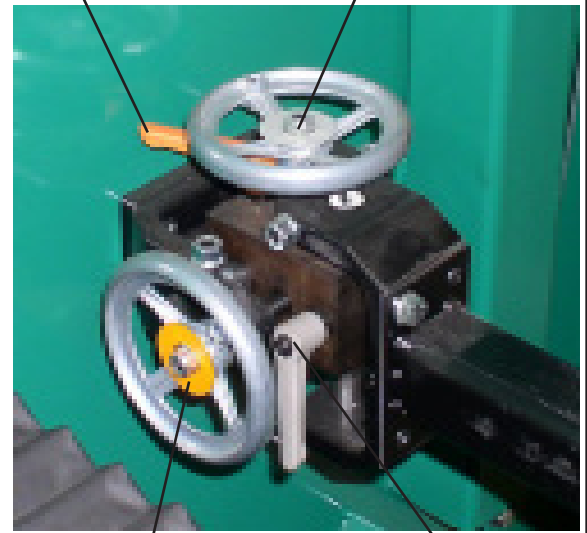

HORIZONTAL ORANGE ADJUSTING HANDWHEEL
GREY VERTICAL LOCKING KNOB

FIG. 47

OVERHEAD CLAMPS

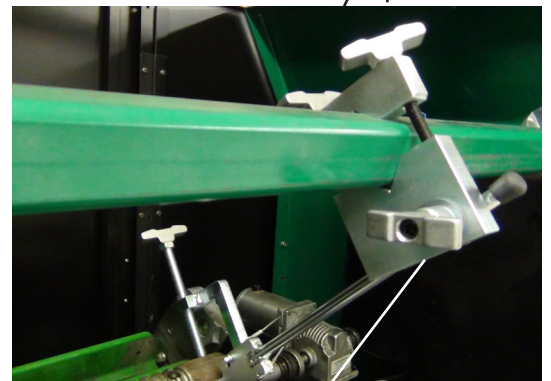

SLIDE BAR CLAMP

FIG. 48

OPERATING INSTRUCTIONS (Continued)

CHECKING REEL FOR CONE SHAPE, REEL ROUNDNESS, AND STRAIGHTNESS OF REEL OUTSIDE DIAMETER.

BEFORE GRINDING--

A. Before storing the set up gauge, it is very effective to use it to check the unground reel to determine the amount the reel is conical in shape and which end has the larger diameter. See FIG.49. Start with the set up gauge at the right end of the reel. Loosen the knob on the indicator stop bar, holding the indicator rod firmly against one blade. See FIG. 46. Pull the indicator stop bar back until it clears the plunger then advance it forward until it contacts the plunger and advances it 1/2 inch further. Lock in place. This sets the plunger at its midpoint and allows adequate movement in both directions. Set outer dial at zero and note position of pointer on small dial.

B. Now move it to the left side of reel and indicate the same blade. From the reading determine the amount the reel is cone shaped. This also determines high point for grinding. Grinding of a reel must always start at the high point.

AFTER GRINDING--

A. After grinding a reel, check the roundness on each end of the reel and center before removing ground reel. See FIG. 50. Loosen the knob on the indicator rod and allow it to contact firmly against one blade. Pull the indicator stop bar back until there is a 1/32" gap between it and the set screw. This is to permit rotation of the reel blades to ride on the domed anvil only. See FIG. 51. At each location (left, right and center) turn the reel by hand and observe the indicator variations. All readings should be within .002".

B. Straightness of reel outside diameter-- Take indicator readings at both ends of reel. Compare readings between each end of reel for straightness. All reading should be within .002".

C. Carefully remove the setup gauge and store it on tool tray.

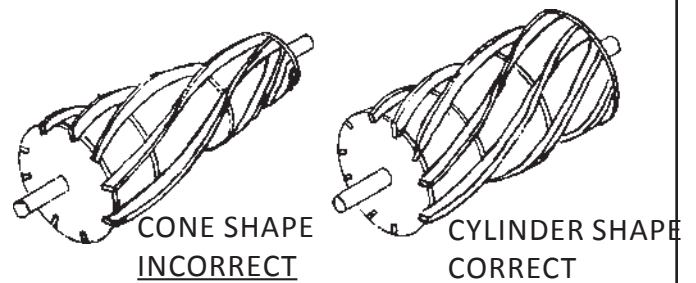

FIG. 49

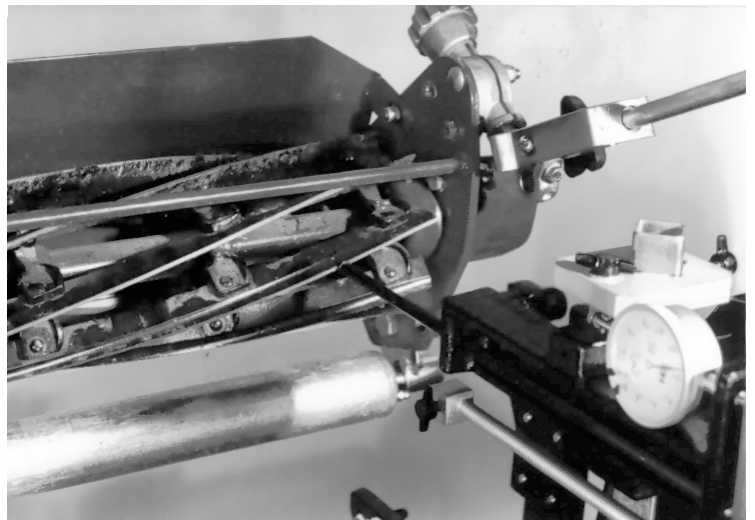

FIG. 50

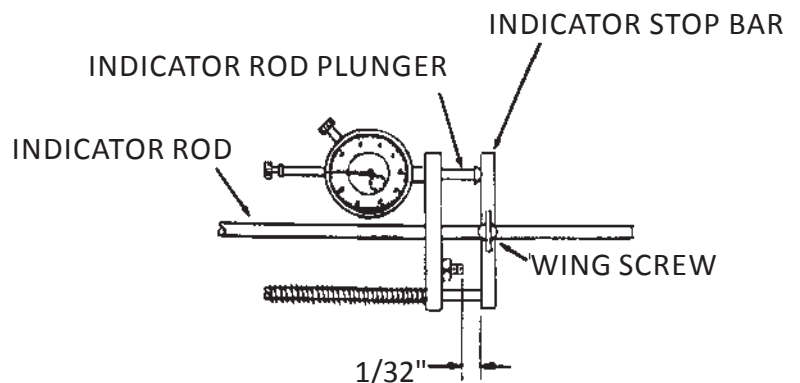

FIG. 51

OPERATING INSTRUCTIONS (Continued)

ATTACHING THE VARIABLE SPEED SPIN DRIVE UNIT TO THE REEL

The spin drive unit attaches to the end of the reel shaft or a drive system component. Consult the cutting unit manual for proper spin drive placement and attachment. Determine which side to mount the spin drive. This will generally be the same drive system component used for backlapping.

IMPORTANT: When spin grinding, the reel should turn in the same direction as the grinding wheel. See FIG. 52.

Before positioning the spin unit let us familiarize ourselves with the available adjustments and coupler/drive assemblies. See FIG. 53 and 54

HANDWHEEL A--

Adjusts the scissor bar to move the unit up and down.

KNOB B (2 EACH)--

Loosen both knobs to move the spin motor forward or back.

KNOB C & D--

Allow the spin assembly to be loosened from the support bar frame and moved side to side.

When positioning the spin unit it will be necessary to complete several of the above adjustments to properly align the spin unit to the reel.

THE COUPLER ASSEMBLY INCLUDES:

RUBBER SLEEVE COUPLER: This is placed in the corresponding flange coupler already mounted in the spin drive shaft. See FIG. 54.

DRIVE COUPLER ADAPTER ASSEMBLY: This is mounted to the rubber coupler.

NOTE: *If the Drive Coupler Adapter is removed, there is a short square drive shaft attached to the Adapter Sleeve. This can be used with a socket if there is limited space.*

ADAPTER SLEEVE: Connects the rubber coupler to the square drive adapter.

SQUARE DRIVE ADAPTER: This is inserted into the drive coupler adapter. The square drive adapter has approximately 2" [51 mm] of movement. It will be necessary to move this when attaching reel to spin drive unit. This adapter shaft has a groove machined into it on the opposite end of the snap ring. This groove is there to advise that you have reached the maximum extension of the square drive shaft. If you cannot connect the reel without extending past this groove, then the spin unit must be repositioned on the tooling bar (Knobs C and D). A 1/2" [12.7 mm] square drive socket or reel drive adapter is used to connect the square drive adapter to the reel.

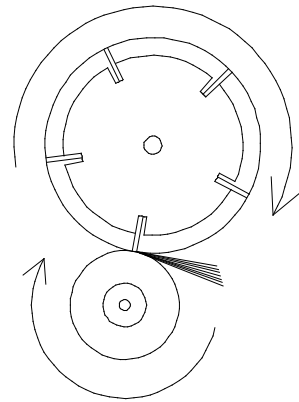

FIG. 52

THE REEL TURNS IN THE SAME DIRECTION AS THE GRINDING WHEEL

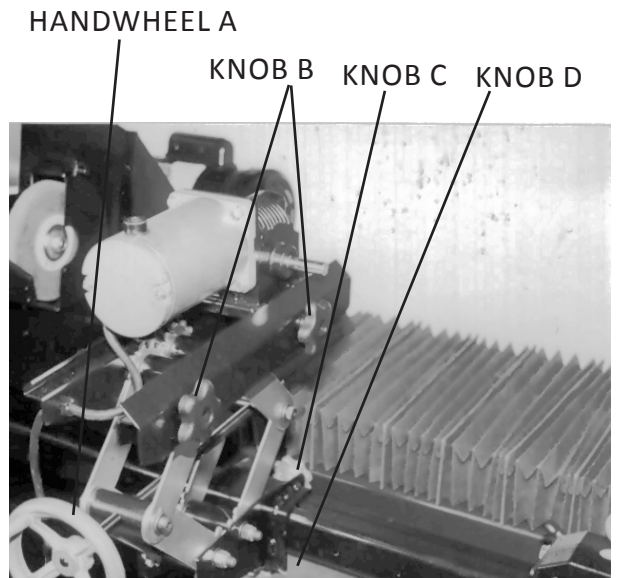

FIG. 53

B. DRIVE COUPLER ADAPTER
C. ADAPTER SLEEVE

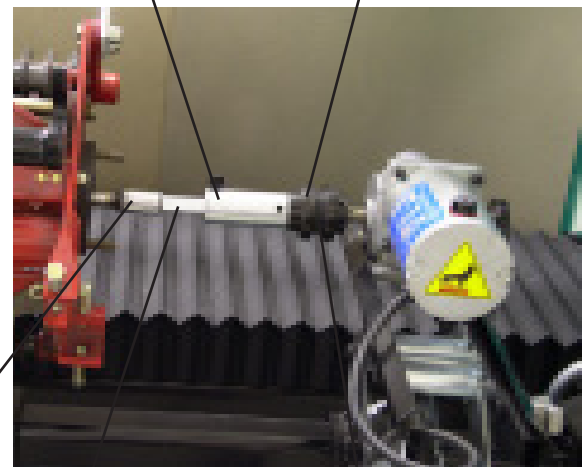

FIG. 54

D. SQUARE DRIVE ADAPTER
A. RUBBER COUPLER

CAUTION

DO NOT EXTEND SQUARE SHAFT PAST GROOVE, INSTEAD REPOSITION SPIN UNIT.

SOCKET OR DRIVE ADAPTER

OPERATING INSTRUCTIONS (Continued)

NOTE: *There are three drive adapters that are included with the machine. If one of these adapters does not work or the reel has a threaded shaft then refer to the Reel Drive Adapter information on the next page.*

The following procedures will make setting up the spin drive unit easier.

1. Move spin drive unit close to the reel. Align the shaft on the spin drive with the drive component on reel by completing the necessary adjustments discussed on the previous page.
2. Now slide the spin drive unit approximately 7" from the reel drive coupling point and securely fasten to the square mounting bar tightening both locking knobs.
3. Place the proper 1/2" square drive socket or adapter on the reel drive component and then insert the square drive shaft into the socket. Place the adapter sleeve over the drive shaft and insert the drive coupler adapter assembly into it. Finally place the rubber coupler onto the drive coupler adapter. See FIG. 55.
4. By holding the square drive shaft firmly into position with your left hand you will be able to move the other components to the right and insert the rubber coupler into the flange on the spin drive unit. When this is done tighten the Tee Knob on the adapter sleeve to hold all parts in place. See FIG. 56.
5. Finally readjust the spin drive unit if it is not in alignment.

NOTE: *It is not necessary to have perfect alignment but it must be close enough so that the coupler remains engaged and that excess torque is not applied to the reel.*

When installing large reels into the grinder there may not be room to install the full spin drive adapter assembly. The Spin Drive Adapter Assembly has been designed so that you can remove the Square Drive Adapter and the Drive Coupler Assembly by loosening the two 1/4-20 knobs. This will expose the square end of Drive Coupler Adapter. This can then be coupled to the reel. See FIG. 57.

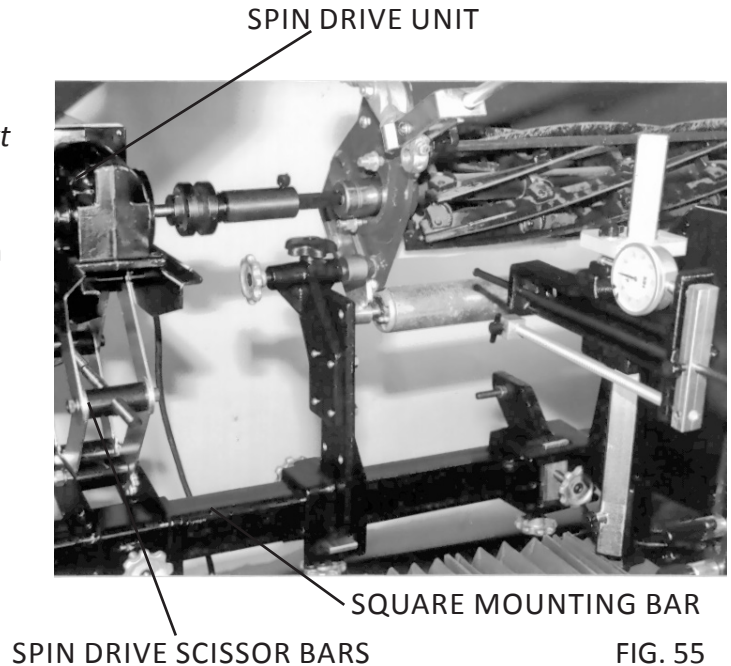

ADAPTER 6009052 ADAPTER SLEEVE 3709584

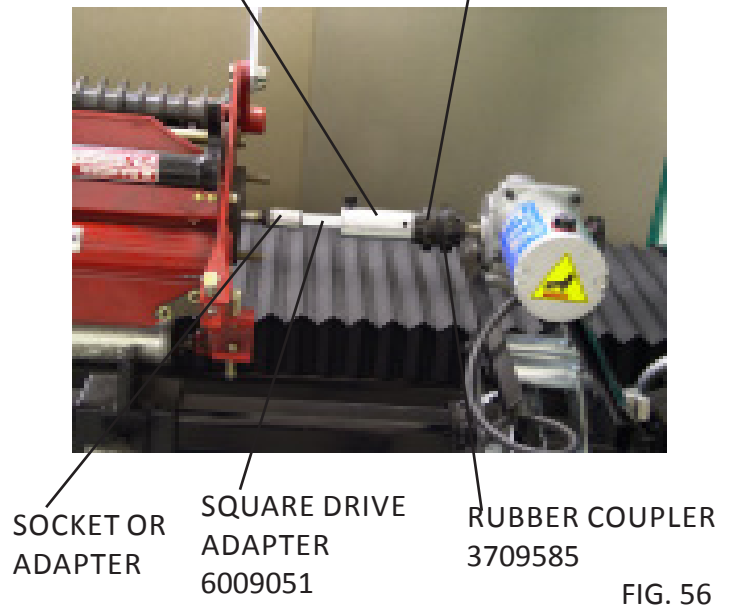

FIG. 56



FIG. 57

OPERATING INSTRUCTIONS (Continued)

REEL DRIVE ADAPTERS

This grinder is equipped with an adapter that transfers the rotation from the spin drive gear box coupling to a 1/2" male square. To operate the grinder you need an adapter from this 1/2" male square to the reel shaft. Three adapters are included with this grinder. For a set please order part number 3706130

Most cutting units manufactured in recent years have a male or female spline on the end of the reel shaft that connects to a hydraulic or electric motor shaft. The three adapters included are the most common splines used on these reels.

If you have a reel shaft that has an internal threaded end which you can access, install a hex head bolt or socket head screw of that thread size with a jam nut very tight so it does not loosen while spin grinding and then drive with a 1/2" drive socket for that hex or hex key size.

TORO EQUIPMENT:

Toro uses an 8 tooth female spline or a 9 tooth female spline on their reels. Adapters for both are included with the grinder.

JOHN DEERE EQUIPMENT:

COUPLERS- The external spline shafts use a female splined coupler between the reel shaft and the male splined hydraulic motor shaft. The spline is either an 8,9 or 11 toothed spline. Our recommendation is to purchase the female splined coupler from John Deere and use it with one of the spline adapters included with this grinder. If one of these adapters does not work, then we recommend that the coupler be welded to a short 1/2" square socket extension.

Note: The 8 tooth spline adapter can be used with a Square Socket Drive Adapter [3/8" square male to 1/2" square female] without welding.

<u>REEL DIA</u>	<u>REEL TYPE</u>	<u>Recomendation</u>
5"	G, M	Has an 8-T, External shaft. Use coupler AET11038
7"	H	Has an 11-T, External shaft. Use coupler TCA12581 (NOTE: THIS CAN ALSO BE DRIVEN WITH A 1.25 HEX SOCKET)
7"	26H	Has a 9-T, External shaft. Use coupler AET11310 (NOTE: THIS CAN ALSO BE DRIVEN WITH A 1.25 HEX SOCKET)
8"	ESP	Has a M16 X 2, External shaft. Use nut A31869 and drive with a 24mm Hex Socket.
5"	WBGM	Use a 3/8"-24 UNF Bolt, and drive with a 9/16 Hex Socket
5"	QA5	Has an 8-T, Internal Spline shaft.
7"	QA7	Has an 11-T, Internal Spline shaft. Use adapters included with the grinder.

JACOBSEN EQUIPMENT:

Below is a list of drive systems based on the cutting units:

* 5" reel units can be driven from the non hydraulic motor end of the reel. Install a 3/8" bolt in the end of the reel shaft with a jam nut very tight so it does not loosen while spinning. Use a 9/16" socket to drive the supplied adapter.

* 7" reel units can be driven from either end. The reel unit has a coupler attached to the reel shaft at both ends. Use the adapters supplied with the grinder.

* Tri-King reel units can be driven on older pulley drive units with a 9/16" socket on the 3/8" bolt that holds the pulley. On newer splined units, use the adapters supplied with the grinder.

OPERATING INSTRUCTIONS (Continued)

SETUP PROCEDURE FOR SPIN DRIVE RPM VERSUS TRAVERSE SPEED

SPIN DRIVE RPM

SPIN DRIVE RPM IS VERY IMPORTANT IN ACHIEVING A QUALITY GRIND. USE CARE IN ESTABLISHING THE SPIN DRIVE RPM, PER THE INSTRUCTIONS BELOW.

Generally, the Spin Drive RPM will be between 180 RPM (45%) and 300 RPM (80%). The speed required to spin a specific reel is dependant on reel diameter, the number of reel blades, and reel hardness. For all reels, there is an optimum Spin Speed where there is an **AGGRESSIVE**, yet smooth grind as you spin grind the reel. Your objective is to spin grind the reel as aggressively and as fast as possible while maintaining top quality.

It is recommended to start grinding each reel at a Spin Speed of 200 RPM (50%) and evaluate the RPM by adjusting higher and lower to optimize the Spin Speed for that reel. If the Spin Speed is incorrectly set, you can experience two problems, grinding wheel dressing or grinding wheel resonance. Each of these problems is explained below.

On some reels, especially small diameter high blade count reels if the Spin Speed RPM is set too high, the reel can act as a dresser to the grinding wheel. There can develop what appears to be a very aggressive grind (as if the infeed has self infed) and then a sudden stop of grinding with no grinding wheel to reel contact. If this occurs, your Spin Speed was set too high and you effectively dressed your grinding wheel.

Some reels have a resonant RPM where the reel goes into harmonics with the grinding wheel and the resonance vibrates the grinder and results in a very bad grind. By changing the Spin Speed to a higher or lower RPM you will move out of the resonant range.

After determining the best Spin Speed RPM for a reel, note the RPM on a "Setup Chart" that you will make. By noting the correct RPM, you will avoid evaluating the Spin Speed the next time you grind the reel.

TRAVERSE DRIVE RPM

The Traverse Speed potentiometer is adjustable from approximately 5 feet per minute [1.5 meters per minute] to 20 feet per minute [6 meters per minute]. It is recommended to grind between 15 and 20 feet per minute [4 and 6 meters per minute].

Grinding at a slower traverse speed, 10 feet per minute [3 meters per minute] as an example, will give a better finish but will extend the grind cycle time. Grind finish versus grind cycle time is controlled by the choice of the operator.

OPERATING INSTRUCTIONS (Continued)

GRINDING REEL INTO A TRUE CYLINDER BY SPIN GRINDING

This ACCU-Sharp model 605 grinder is equipped with two grinding wheels and two grinding wheel guards. Prior to spin grinding install or verify installation of the 1" (25 MM) wide grinding wheel and the spin wheel guard which has no fingers attached. See FIG. 58

A. Before you proceed any further, check all knobs to insure they are tight.

FIRMLY TIGHTEN ALL LOCKING KNOBS BEFORE GRINDING. ANY LOOSENESS WILL ADVERSELY AFFECT GRIND QUALITY.

B. There are three (3) lock handles for locking the grinding wheel vertically. Two (2) on the base for the adjusting arm locks and one for grinding wheel vertical height adjustment locking screw. See FIG. 59.

C. Position the height of the grinding wheel center so that it is 0 to 1" below the reel center. See FIG. 60.

D. Infeed the grinding wheel until it just makes contact with a reel blade while rotating the reel by hand. Now tighten the two locking knobs on the locking arms and the locking knob for the height adjustment screw. Back the grinding wheel off so it just clears the reel.

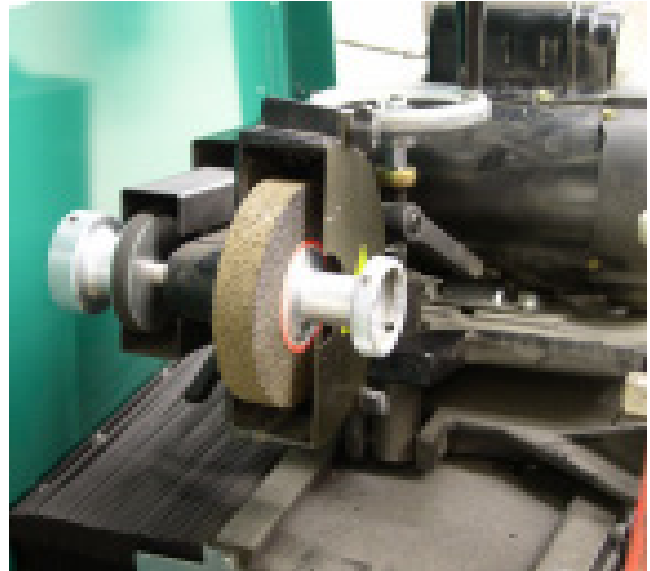
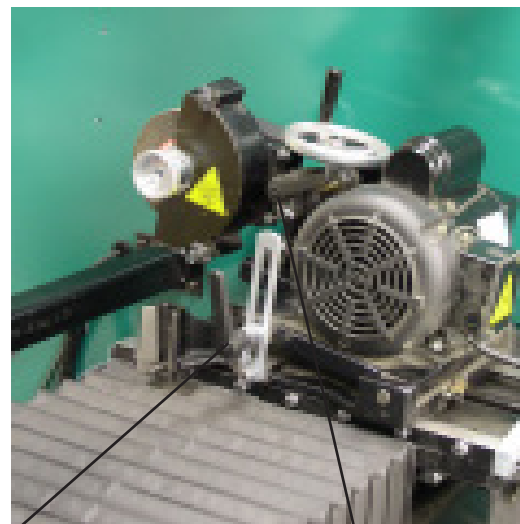

FIG. 58



LOCK HANDLE
ADJUSTING ARMS
(1) EACH SIDE

LOCK HANDLE
VERTICAL
ADJUSTMENT LOCK

FIG. 59

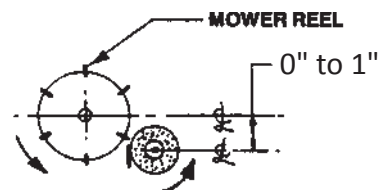

**THE REEL AND GRINDING WHEEL
ARE TO ROTATE IN THE SAME DIRECTION.**

FIG. 60

OPERATING INSTRUCTIONS (Continued)

GRINDING REEL INTO A TRUE CYLINDER BY SPIN GRINDING (CONTINUED)

E. Move the grinding wheel to the right until the wheel has cleared the reel by approximately $\frac{1}{4}$ inch [6 mm] (if clearance to the frame allows). Turn the Traverse speed potentiometer to zero. Turn on the Traverse Motor Switch, this will activate the proximity sensors. Move the right Traverse Travel Limit switch in until the light on the proximity sensor illuminates. Move the wheel to the opposite end of the reel until the wheel clears the end of reel by $\frac{1}{4}$ inch [6 mm] (if clearance to the frame allows). Set the left Traverse Travel Limit Switch. Engage the traverse belt, if not already, and slowly turn the Traverse Speed up. Allow the wheel to traverse from end to end to verify the switches stop and reverse the direction of the grinding wheel. Verify that the grinding wheel travels fully off the reel at each end.

CAUTION, IF THE REEL FRAME EXTENDS BELOW THE REEL ITSELF, MAKE SURE THE STOP IS SET SO THAT THE GRINDING WHEEL WILL NOT RUN INTO FRAME WHEN GRINDING. IT IS POSSIBLE THAT IN SOME CASES THIS WILL MEAN THE GRINDING WHEEL WILL NOT CLEAR THE END OF THE REEL WHEN GRINDING.

F. Move grinding carriage to the high side end of the reel and stop the carriage. Set the Grind Selector Switch to Variable Speed Spin.

CLOSE THE FRONT AND REAR DOORS.

G. Turn on the spin drive motor and check to see if reel is spinning freely and that the spin drive and coupler is properly aligned.

IH. With the spin drive running at 200 RPM, turn on the grinding wheel motor. Verify that the spin rotation is the same direction as the grinding wheel, clockwise, looking at the right end of the reel from the operators position. Now slowly infeed the grinding wheel until it makes light contact with the reel. See FIG. 63.

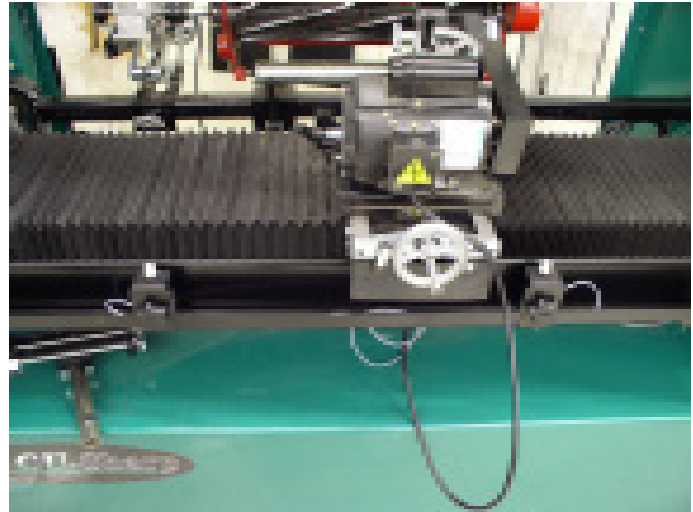

FIG. 61

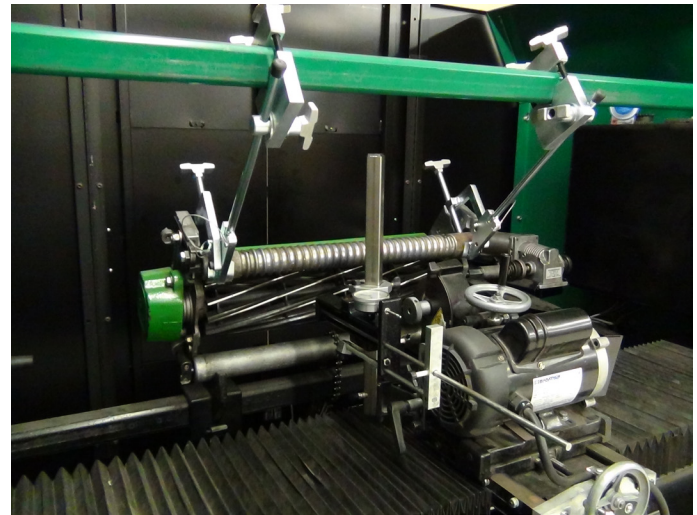

FIG. 62

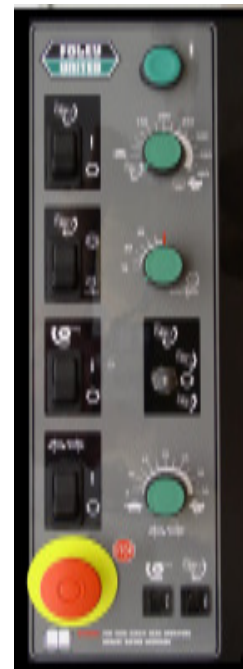

FIG. 63

OPERATING INSTRUCTIONS (Continued)

GRINDING REEL INTO A TRUE CYLINDER BY SPIN GRINDING (CONTINUED)

I. Set traverse speed knob to approximately "12", then turn on the traverse switch and begin grinding. If reel is in bad condition, traverse slower as more material can be removed. Conversely, if the reel is in good condition, speed can be increased.

MAXIMUM RECOMMENDED STOCK REMOVABLE PER PASS IS .004. NOTE: THE INFEED HANDLE IS CALIBRATED IN INCREMENTS OF .002 (.05 MM) ON THE RING SCALE LOCATED ON THE INSIDE OF THE INFEED HANDLE.

J. If grinding wheel is only making contact in one part of the reel, adjust the traverse stop so the carriage traverses slightly further than the contacted area. As you infeed and the wheel makes full contact in this area, move the traverse stop away 3" [7.6 cm] to 5" [12.7 cm]. This will speed up the grinding process of getting a cone shaped reel into a true cylinder.

K. Spin grinding is completed when full contact is made across the entire length of the reel and the entire width of all blades and the cutting edge is sharp.

L. To complete grinding the outside diameter to a true diameter, proceed to spark out the reel. To spark out the reel, infeed the grinding head approximately .002" [.05 mm] (one line on the ring scale) and let the grinding wheel sparkout. During sparkout allow the grinding head to make at least 20 traverse passes with no additional infeed. Set traverse at a slow speed on dial, approximately 4 to 8 feet per minute, as this will give the best results. After the sparkout grind, shut the grinder completely off.

NOTE: This process refers to sparkout, but what we are looking for is a near sparkout, approximately a 99% reduction in grinding sparks from normal grind. Do not run sparkout until you have no sparks because this could be an extremely extended period.

NOTE: Greatest accuracy and best finish is obtained when reel is sparked out. Use your set up gauge, prior to relief grinding to check the reels for roundness. This is very important when first learning the operation of your machine.

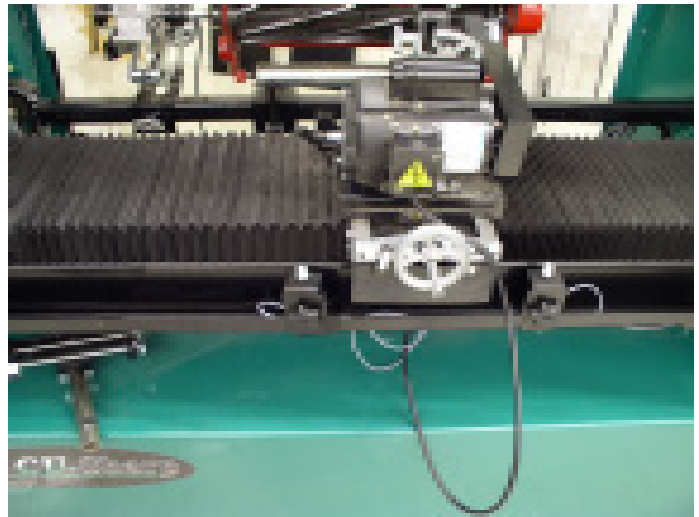

FIG. 64

IT IS VERY IMPORTANT IN SPIN GRINDING THAT YOU THOROUGHLY SPARKOUT AT THE END OF THE GRIND CYCLE. THE DIFFERENCE BETWEEN ACHIEVING .005 OR .003 TOTAL INDICATOR READING IS ACCOMPLISHED THROUGH PROPER SPARKOUT.

OPERATING INSTRUCTIONS (Continued)

REEL SPIRAL OR HELIX

FRELIEF GRINDING TO COMPLETE THE REEL GRINDING PROCESS

A. This grinder is equipped with two grinding wheels and two grinding wheel guards. Prior to relief grinding install or verify installation of the 3/8" (9.5 MM) wide grinding wheel and the relief wheel guard which has the relief and index fingers attached. See FIG. 65.

B. Check to see if your mowing unit is normal or reverse helix. When standing behind the mowing unit when the mowing unit is sitting in the normal position on the ground, if the spiral is such that the right side of the blade cuts before the left, it is a right hand lead in or a right hand spiral reel. If the spiral is such that the left side of the blade cuts before the right it is a left hand lead in or left spiral reel. Most reels made today are right hand and are referred to as normal helix.

NOTE: As you look into the guide finger on PAGE 40, IT SHOWS THE NORMAL REEL HELIX. The high point of the relief finger is on the right hand side of the grinding wheel.

As you look into the guide finger on PAGE 41, IT SHOWS THE REVERSE REEL HELIX. The high point of the relief finger is on the right hand side of the grinding wheel.

Most mowing units are normal helix.

C. Reset the Traverse Limit Proximity Switch so the grinding wheel clears the reel at both ends by approximately 1/16" (1.5 mm) or the reel blade comes off the relief finger on the right side. See FIG. 66 - 71.

D. Set Grind Selector to variable torque relief.

NOTE: The Spin Drive switch must be in the OFF position when changing Grind Selector switch.

Set Spin Drive Rotation switch to rotate the reel into the stop finger, counterclockwise (CCW) when looking at the right side.

NOTE: Relief torque reel rotation is always opposite spin rotation.



BACK STOP KNOB

FIG. 65

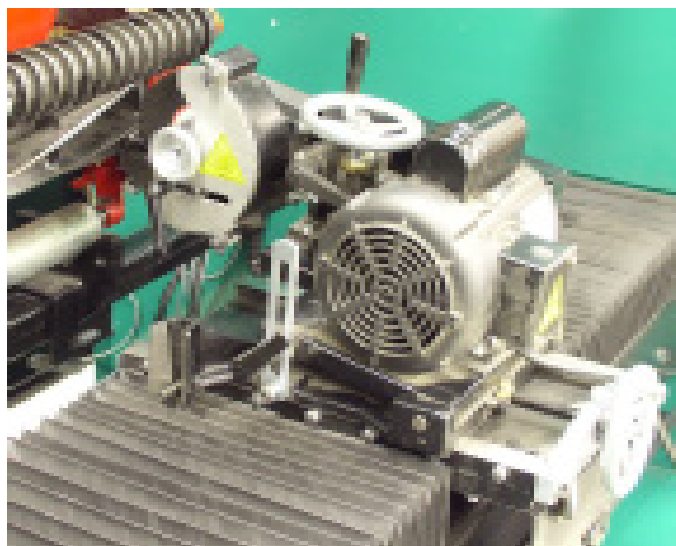

FIG. 66

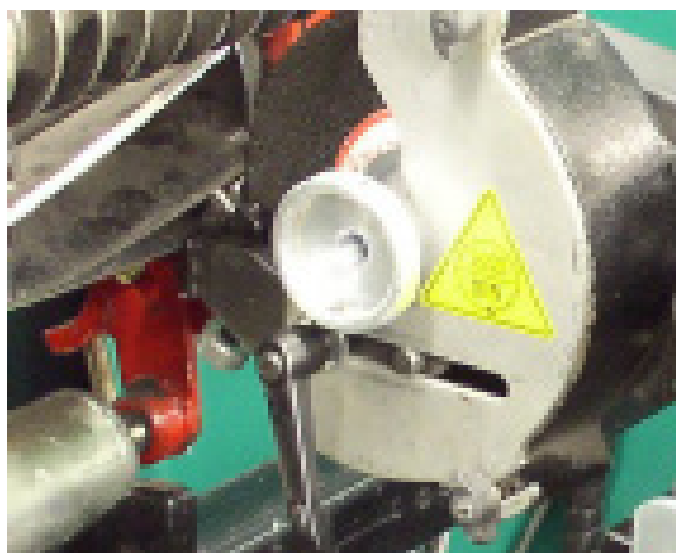

FIG. 68

OPERATING INSTRUCTIONS (Continued)

REEL SPIRAL (CONTINUED)

E. Loosen the two (2) vertical adjustment lock handles on the carriage base. Use the vertical adjustment handwheel to raise the grinding head up approximately seven (7) turns so the reel blade can rest on the reel guide finger. It will be necessary to infeed the grinding wheel to accomplish this. See FIG. 66.

F. Adjust the position of the grind wheel to achieve the desired relief angle. (The average recommended manufacturer's angle is 20 to 40 degrees. Check with the cutting unit manual as to the exact angle required.) By looking down the reel from the operator's position you can see the reel blade and its relative position to the grinding wheel. By raising the grinding wheel you will decrease the relief angle and conversely by lowering the grinding wheel you will increase the relief angle. When the relief angle is correct, traverse the grinding wheel assembly to the right side of the reel. Retighten the two vertical adjustment (2) lock handles.

G. Adjust the index finger positioning by rotating the back stop knob on the bottom forward of the grinding head. This position must allow approximately 1/16" (1.5 mm) free play of the index finger when the blade is resting on the high point of the relief finger. See FIG. 66-67. The Index Finger position must be set to stop the reel blade and allow traversing to the left without the blade hitting the side of the relief finger.

H. Turn the traverse speed potentiometer to zero, then turn the traverse drive motor on. Using the speed potentiometer to slowly move and stop the grinding wheel, move left until the reel blade is on the fixed relief finger.

I. Adjust the grinding head forward until there is minimal clearance between the reel blade and the grinding wheel.

J. Adjust the index finger positioning by rotating the back travel adjust knob on the away side of the grinding head. This position must allow approximately 1/32" (1 mm) free play of the index finger when the blade is resting on the high point of the relief finger. See FIG. 65-67

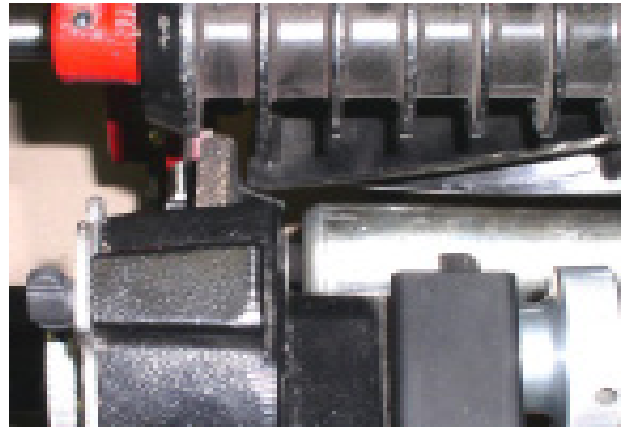

FIG. 68

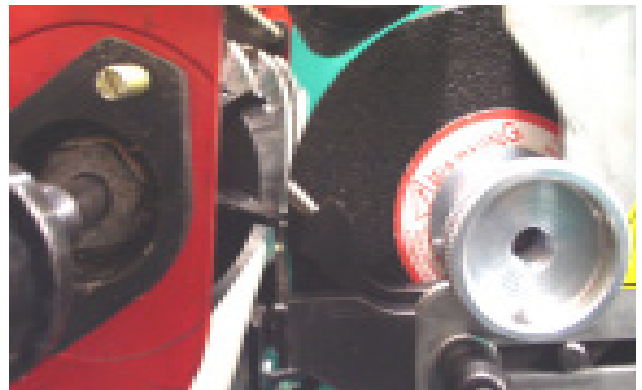

FIG. 69



FIG. 70



FIG. 71

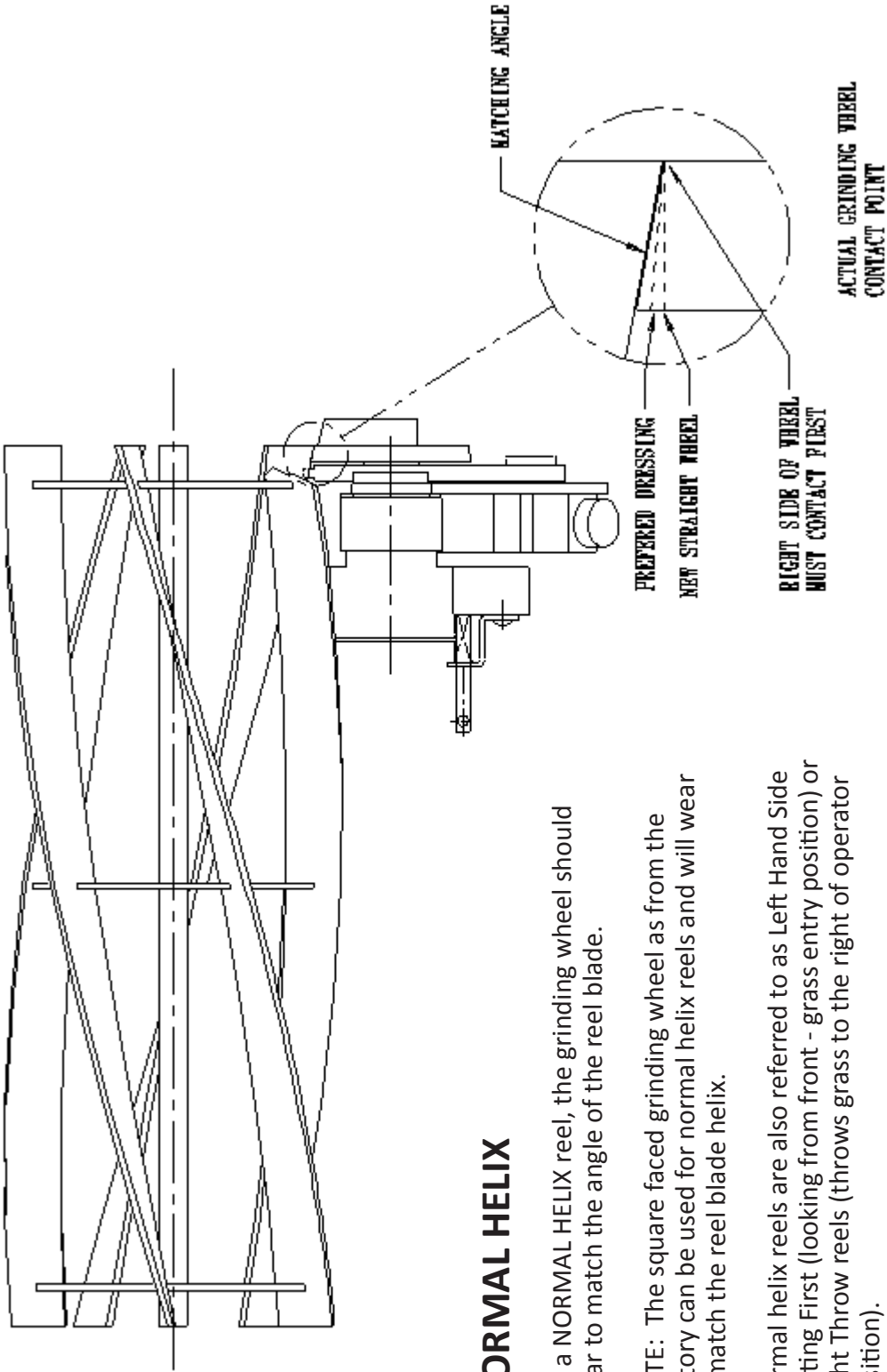

NORMAL HELIX

For a NORMAL HELIX reel, the grinding wheel should wear to match the angle of the reel blade.

NOTE: The square faced grinding wheel as from the factory can be used for normal helix reels and will wear to match the reel blade helix.

Normal helix reels are also referred to as Left Hand Side Cutting First (looking from front - grass entry position) or Right Throw reels (throws grass to the right of operator position).

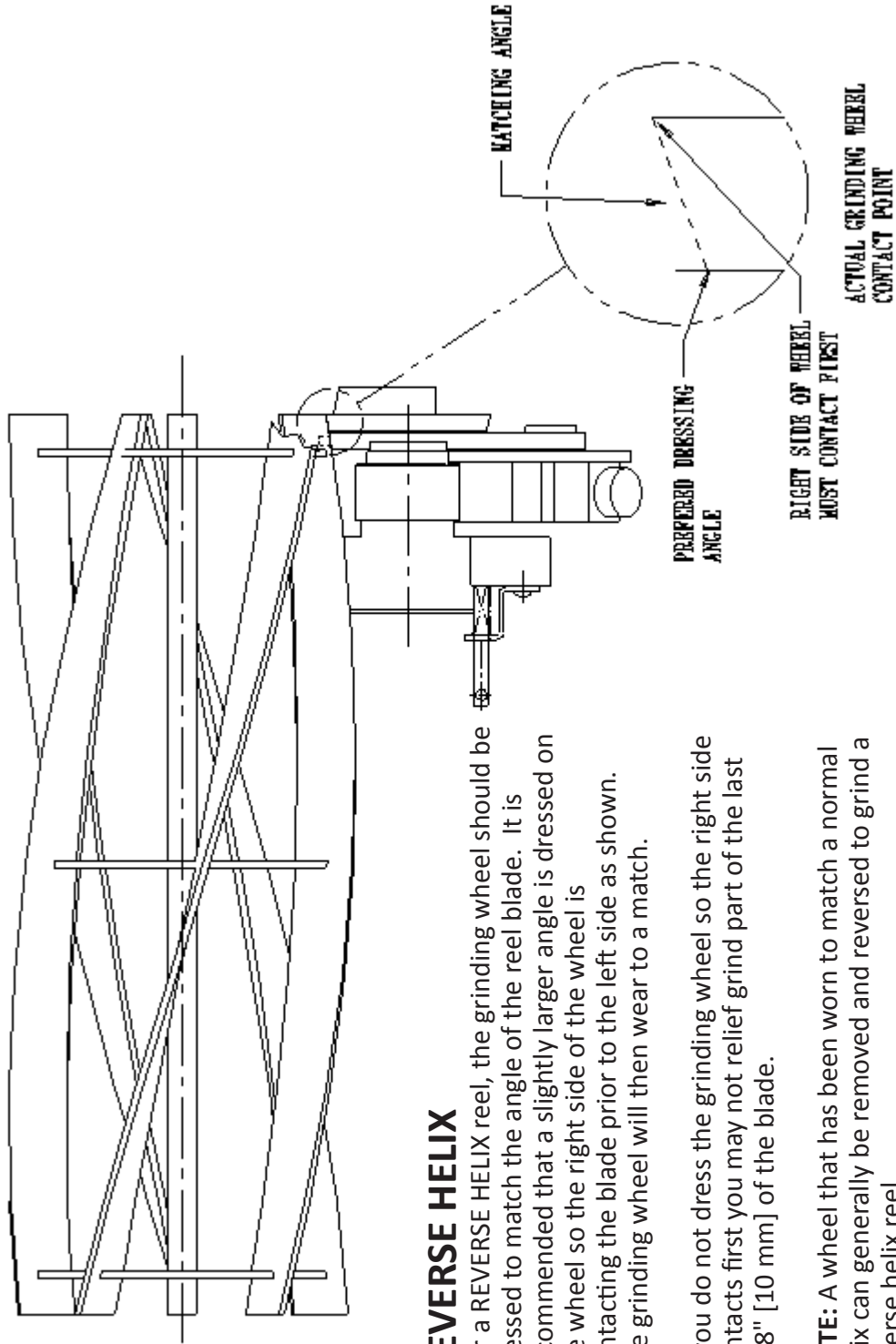

REVERSE HELIX

For a REVERSE HELIX reel, the grinding wheel should be dressed to match the angle of the reel blade. It is recommended that a slightly larger angle is dressed on the wheel so the right side of the wheel is contacting the blade prior to the left side as shown. The grinding wheel will then wear to a match.

If you do not dress the grinding wheel so the right side contacts first you may not relief grind part of the last 3/8" [10 mm] of the blade.

NOTE: A wheel that has been worn to match a normal helix can generally be removed and reversed to grind a reverse helix reel.

Reverse helix reels are also referred to as Right Side Cutting First reels (looking from the front - grass entry side) or Right Throw reels (throw's grass to the right of the operator position).

OPERATING INSTRUCTIONS (Continued)

K. CLOSE THE FRONT AND REAR GUARD DOORS

L. Turn the Torque Potentiometer to zero. Turn the Spin Drive motor on. Slowly turn the Relief Torque Potentiometer up to approximately 15.

NOTE: Free turning reels may need a lower value than 15. Stiff reels or reels with a drive train may need a higher torque than 15. Do not exceed 45 on the relief torque potentiometer setting.

M. Traverse the grinding head all the way to the left prox switch watching for proper clearance between the grinding wheel and the blade. When the grinding head reaches the left prox, the index finger should pop forward. See FIG. 69. The grinding wheel should come off from the reel blade, but the reel blade should remain on the fixed relief finger. See FIG. 68 Check for proper clearance between the index finger and the front side of the blade on the return trip to the home position. See FIG. 70.

The Index finger has a forward travel adjustment on the bottom of the finger. See FIG. 72. The forward travel adjustment can be adjusted to allow greater forward travel for reels that require more forward travel such as reverse helix reels and can be adjusted to limit forward travel on small tight spaced reel blades.

Also verify clearance between the index finger and the reel blade support spiders.

N. Stop the traverse in home position and check for a proper blade index. See FIG. 71. The traverse drive control is factory set with a two second dwell time before it reverses the carriage travel. This is to allow time for the reel to rotate and the index finger to catch the next blade. If necessary the dwell time can be adjusted (refer to Control Board Potentiometer Adjustments section in the Assembly and Service Manual).

O. Allow the grinder to traverse down and back to verify everything is properly set up. Turn the traverse potentiometer to zero once the home position is reached.

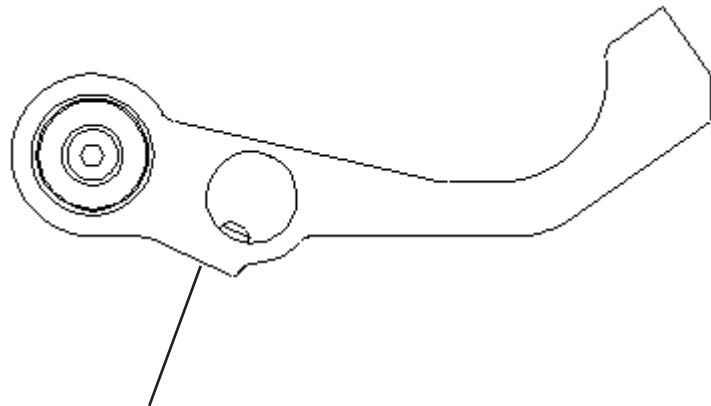

FINGER FORWARD TRAVEL
ADJUSTMENT SETSCREW

FIG. 72

P. Turn on the Grinding Wheel Motor.

Q. Turn on the traverse speed pot to a proper grinding speed. Slowly infeed the grinding wheel until you are able to grind the full length of the reel blade evenly. You can infeed between .005" to .012" at a time. Be sure you have ground all the blades before infeeding further.

NOTE: Traverse speed should be approximately 15 fpm. If you are removing a small amount of stock on initial infeeds, faster traverse speeds are suggested. If you are removing a large amount of stock on later infeeds, slower traverse speed may be required.

WHEN YOU HAVE SUCCESSFULLY COMPLETED THE SPIN GRIND AND RELIEF GRIND ON A GIVEN MOWING UNIT TYPE, THEN MEASURE AND COMPLETE THE SETUP CHART ON THE LAST PAGE OF THIS MANUAL.

