

# **CONVERSION OF TRAVERSE DRIVE CONTROL (TDC) FROM DART 3707082 TO MINARIK 6009557**

Control Board #6009557 is a direct replacement for all model machines listed: 396, 3084, 3055, 3096, 600, 610, and 640. The new control board works on all models which have limit switch or proximity switch controlling the reversing of the grinding head stroke.

## **TO REPLACE THE CONTROL BOARD**

1. Remove all wiring from the existing control and remove the 4 kep nuts.
2. Mount the new control into the electrical panel using the 4 kep nuts.
3. Hook up wires according to wiring diagram #6007961 for the main power cord, traverse potentiometer, 90 volts DC motor and the appropriate wiring for either limit switch or proximity switches.
4. With the traverse speed potentiometer turned to zero (full CCW), check the limit switch or proximity switch hookup. NOTE: Checkout is always as the operator looks at the machine from the control panel position.

### **Proximity Switch Checkout.**

- A) Proximity switch activated with a piece of metal on the left side (prox light on) control board PROX 1 FWD LIMIT (left prox). Green light is to be on.
- B) Proximity switch activated with a piece of metal on the right side (prox light on) control board PROX 2 REV LIMIT (right prox). Green light is to be on.
- C) Should the control board prox #1 and #2 light the opposite as listed above, unplug the main power and reverse black wires on terminals #13 and #14.

### **Limit Switch Checkout.**

NOTE: Checkout is always as the operator looks at the machine from the control panel position.

- A) Activate the limit switch by hand from the left side. Control board PROX 1 FWD LIMIT (Switch activated from the left side). Green light is to be on.
  - B) Activate the limit switch by hand from the right side. Control board PROX 2 REV LIMIT (Switch activated from the right side). Green light is to be on.
  - C) Should the control board prox #1 and #2 light the opposite as listed above, unplug the main power and reverse the red and black wires on terminals #13 and #14.
5. Plug the main power back in and turn the traverse speed potentiometer up to check that the grinding head traversing works properly.

**Diagnostic LED's indicate the function that is currently being performed:**

- **POWER** indicates that ac power is being applied to the control.
- **FORWARD** indicates that the process is running in the forward direction (traversing left).
- **REVERSE** indicates that the process is running in the reverse direction (traversing right).
- **PROX 1 FWD LIMIT** lights when the forward switch is actuated (left prox).
- **PROX 2 REV LIMIT** lights when the reverse limit switch is actuated (right prox).
- **DWELL** lights when the process remains stopped after a proximity switch is actuated.

# TROUBLESHOOTING - TRAVERSE DRIVE CONTROL (TDC) 6009557

1. Grinding head traverse drive does not reverse -  
check if the proximity switch is functioning and is wired according to the drawing. If the proximity switches are wired correctly, and the drive does not reverse when a switch is actuated, check the switch first.

Left proximity (PROX 1) check between terminals #14 (black wire) and #15 (brown wire).

Proximity light on--0 Volts DC

Proximity light off--12 Volts DC

Right proximity (PROX 2) check between terminals #13 (black wire) and #15 (brown wire).

Proximity light on--0 Volts DC

Proximity light off--12 Volts DC

Replace proximity switch if the voltages do not read as above.

2. Grinding head traverse drive does not run at desired speed, or no speed control.  
Check that the speed pot is properly connected to pins 7, 8, and 9.  
Check potentiometer function. Remove wires 7, 8, and 9 from terminals.

Check: Traverse speed pot check for 10,000 ohms

NOTE: Potentiometer has red, white and black wires or orange, red and white wires.

Red wire to white wire, or orange wire to red wire.

Full CCW--10,000 ohms.

Full CW--0 ohms.

Red wire to black wire, or red wire to white wire.

Full CCW--0 ohms.

Full CW--10,000 ohms.

Replace traverse speed pot if the full range ohm reading is not met.

3. Grinding head traverse does not function in either reverse (traverse left) or forward (traverse right).  
Check voltage across A1 to A2. Put Traverse Speed Potentiometer (TSP) to maximum speed and output voltage at A1 to A2 should be 90 Volts DC to DC motor.

Replace Traverse Drive Control (TDC) if there is no voltage to the DC motor.

## POTENTIOMETER ADJUSTMENTS TRAVERSE DRIVE CONTROL (TDC) 6009557

Min. Speed--Factory set at full (CCW) 8:30. Do not change this setting.

(Right Traverse) Forward Torque--Factory set at full (CW) 4:30. Do not change this setting.

(Left Traverse) Reverse Torque--Factory set at full (CW) 4:30. Do not change this setting.

IR COMP--Factory set to 9:00. Regulation of a traverse motor may be improved by slight adjustment of the IR COMP trim pot clockwise from its factory-set position. Overcompensation causes the motor to oscillate or to increase speed when fully loaded. If you reach such a point, turn the IR COMP trim pot counterclockwise until the symptoms disappear.

Max. Speed--Set at 3:30 for maximum voltage of 90 Volts DC to the traverse motor. When voltage is above 90 volts DC, the traverse motor will start to pulsate and not run smoothly.

(Right Traverse) Forward Acceleration--Factory set at full (CCW) 8:30. Do not change this setting.

(Left Traverse) Reverse Acceleration--Factory set at full (CCW) 8:30. Do not change this setting.

(DB) Dead Band is the potentiometer setting for the 50 or 60 Hz cycle control. Factory set to 9:00, works for both 50 and 60 Hz. Do not change this setting.

Dwell time is preset to #2 setting for a 1 second dwell time when reversing at each end of stroke. A setting of 4, sets the dwell time at 2 seconds, etc.

# TRAVERSE DRIVE CONTROL (TDC) 6009557 WIRING DIAGRAM W POTENTIOMETER SETTINGS

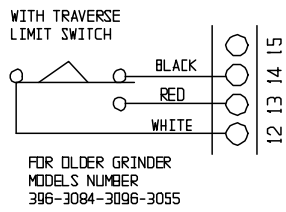
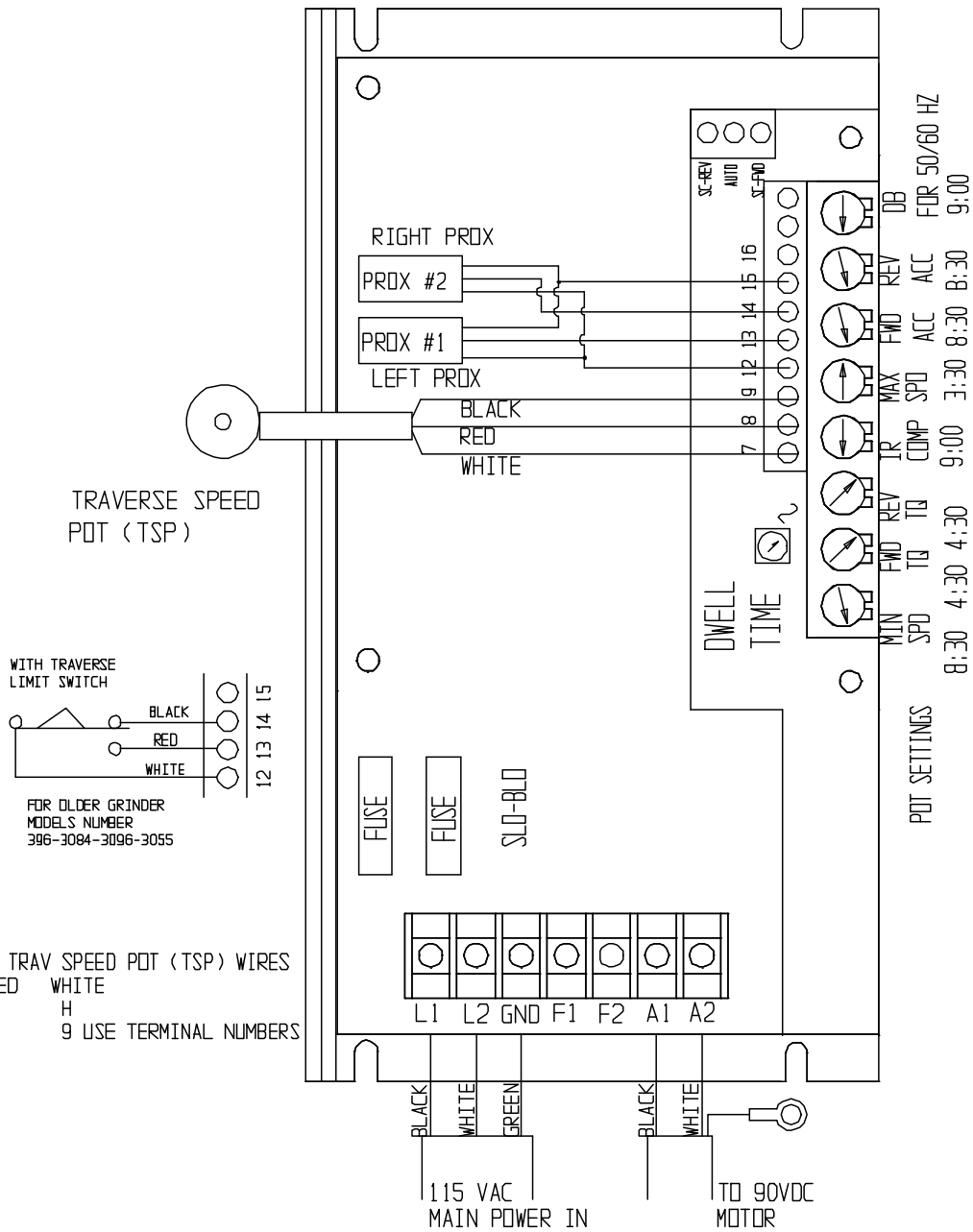
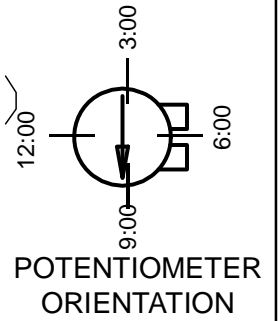

WHEN USING TRAV SPEED POT (TSP) WIRES  
ORANGE RED WHITE  
L W H  
7 8 9 USE TERMINAL NUMBERS