

MODEL 3096
ACCU-SPIN REEL MOWER GRINDER

**ASSEMBLY
AND
OPERATING
INSTRUCTIONS**



WARNING!

You must thoroughly read and understand this manual before operating or maintaining the equipment, paying particular attention to the Warning & Safety instructions.

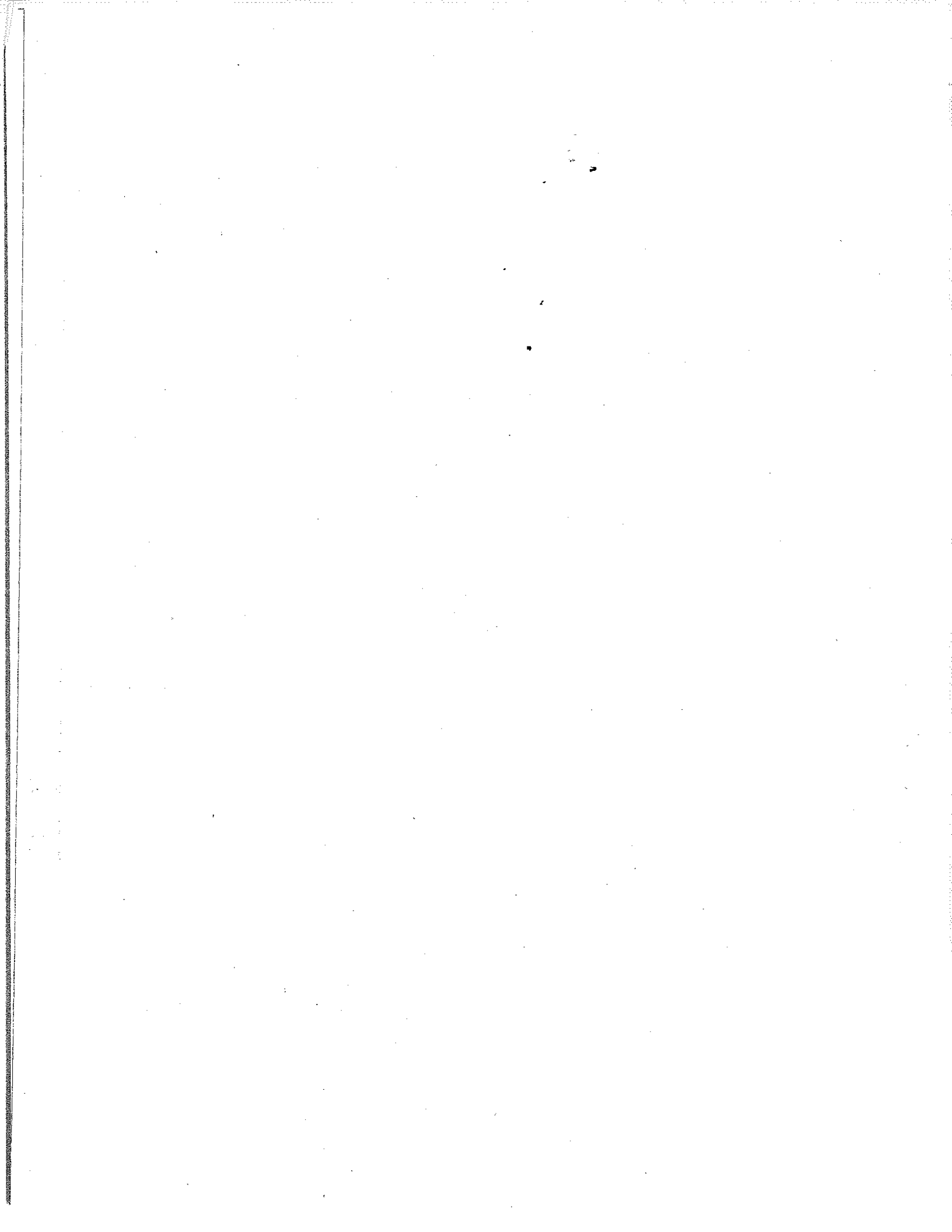

SAFETY INSTRUCTIONS



Safety Awareness Symbols are inserted in this manual to alert you to possible **Safety Hazards**. Whenever you see these symbols, heed their instructions.



The **Warning Symbol** identifies special instructions or procedures which, if not correctly followed, could result in personal injury, or loss of life.

The **Caution Symbol** identifies special instructions or procedures which, if not strictly observed, could result in damage to, or destruction of equipment.

- 1. KEEP GUARDS IN PLACE**
and in working order.
- 2. REMOVE ADJUSTING KEYS AND WRENCHES.**
Form the habit of checking to see that keys and adjusting wrenches are removed from tool before turning it on.
- 3. KEEP WORK AREA CLEAN.**
Cluttered areas and benches invite accidents.
- 4. DON'T USE IN DANGEROUS ENVIRONMENT.**
Don't use power tools in damp or wet locations, or expose them to rain. Keep work area well lighted.
- 5. KEEP CHILDREN AWAY.**
All visitors should be kept a safe distance from work area.
- 6. MAKE WORKSHOP KID-PROOF.**
With padlocks, master switches, or by removing starter keys.
- 7. DON'T FORCE TOOL.**
It will do the job better and safer at the rate for which it was designed.
- 8. USE RIGHT TOOL.**
Don't force tool or attachment to do a job for which it was not designed.
- 9. WEAR PROPER APPAREL.**
Wear no loose clothing, gloves, neckties, rings, bracelets, or other jewelry which may get caught in moving parts. Nonslip footwear is recommended. Wear protective hair covering to contain long hair.
- 10. ALWAYS USE SAFETY GLASSES.**
Also use face or dust mask if cutting operation is dusty. Everyday eyeglasses only have impact resistant lenses, they are NOT safety glasses.
- 11. SECURE WORK.**
Use clamps or a vise to hold work when practical. It's safer than using your hand and it frees both hands to operate tool.
- 12. DON'T OVERREACH.**
Keep proper footing and balance at all times.
- 13. MAINTAIN TOOLS WITH CARE.**
Keep tools sharp and clean for best and safest performance. Follow instructions for lubricating and changing accessories.
- 14. DISCONNECT POWER FROM TOOLS**
Before servicing, when changing accessories, such as blades, bits, cutters, and the like.
- 15. REDUCE RISK OF UNINTENTIONAL STARTING.**
Make sure switch is in off position before plugging in.
- 16. USE RECOMMENDED ACCESSORIES.**
Consult the equipment manufacturer's manual for recommended accessories. The use of improper accessories may cause risk of injury to person.
- 17. NEVER STAND ON TOOL.**
Serious injury could occur if the tool is tipped or if the cutting tool is unintentionally contacted.
- 18. CHECK DAMAGED PARTS.**
Before further use of the tool, a guard or other part that is damaged should be carefully checked to determine that it will operate properly and perform its intended function—check for alignment of moving parts, binding of moving parts, breakage of parts, mounting, and any other conditions that may affect its operation. A guard or other part that is damaged should be properly repaired or replaced.
- 19. NEVER LEAVE TOOL RUNNING UNATTENDED. TURN POWER OFF.**
Don't leave tool until it comes to a complete stop.
- 20. KNOW YOUR POWER TOOL.**
Read the owner's manual carefully. Learn application and limitations as well as specific potential hazards peculiar to this tool.
- 21. KEEP ALL SAFETY DECALS CLEAN & LEGIBLE.**
If safety decals become damaged or illegible for any reason, replace immediately. Refer to the Exploded View drawings at the back of the manual for the proper location and order numbers of safety decals.

TABLE OF CONTENTS

Safety Instructions	3
Assembly Instructions	5-12
Specifications	13
Getting to Know Your Grinder	13-16
Operating Instructions	18-36

ASSEMBLY INSTRUCTIONS

UNPACK CARTONS

It is recommended that only one carton be opened at a time and the parts inside checked against the enclosed packing slip. They should be opened and assembled in the following sequence.

1. Elevator Assembly
2. Overhead Support Assembly
3. Miscellaneous Parts Box
4. Grinding Head Assembly
5. Vacuum Dust Collecting System
6. Spin Drive Assembly
7. Set Up Gauge

If any problems occur, refer to the shipping and receiving instructions. Double check the packing cartons for any miscellaneous items or other manuals before disposing of cartons.

Remove the grinder base from the wood pallet. This is accomplished by unbolting the angle brackets that hold each base stand to the bottom of the wood pallet. The four leveling screws are seated in countersunk holes in the wood pallet. To remove the grinder from the pallet, you must first lift one end of the grinder high enough so both leveling feet are out of their countersunk holes.

Then prop this end up so the leveling feet on this end are held out of the countersunk holes. Then lift the other end out of the countersunk holes and lift grinder off from the pallet.

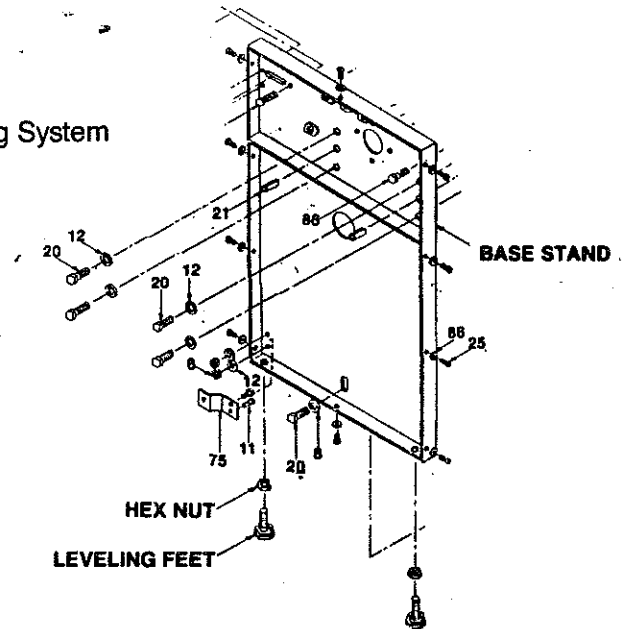
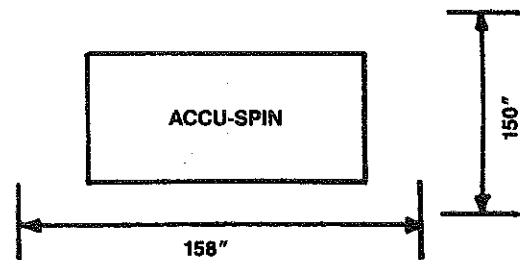

FIG. 1

POSITION BASE

The Accu-Spin will require an operating area about 158"W x 150"D x 87"H. The mower reel will be lifted from behind the machine, and the machine operator will stand in front of it. Position the base to allow sufficient operating room both in front and behind the machine.

The base should be placed on a relatively level concrete floor, with ample ceiling height to allow for the installation and operation of the reel elevator. Do not place the unit across two concrete slab seams or across a large crack.



VIEW FROM
ELECTRICAL PANEL POSITION

FIG. 2



CAUTION: Placing the grinder on flooring that is badly out of level or broken will affect grinding quality.

ASSEMBLY INSTRUCTIONS

LEVEL BASE

Place a level on the top of the front carriage rail near the center of the machine and check the level from left to right. Adjust the leveling feet as necessary to bring to level.

Place a level across the front and rear carriage rails near the left end of the carriage bed. Adjust the two leveling feet on the left end of the machine as necessary to level the left end.

Place a level across the two carriage rails at the right end of the machine and adjust to level. These two steps will level the machine from front to back.

NOTE: Leveling from left to right is critical. The base must be level within .001 from side to side. Measure with a precision level to insure accuracy.

When both front to back and side to side leveling procedures have been completed, thread the hex jam nuts up against the nut that is welded to the bottom of the base until they lock into place. Be careful not to move the leveling feet during this process.

Recheck with level after locking nuts are firmly tightened.



CAUTION: Failure to properly level your grinder, or bumping it, or knocking it off level will adversely affect grind quality.

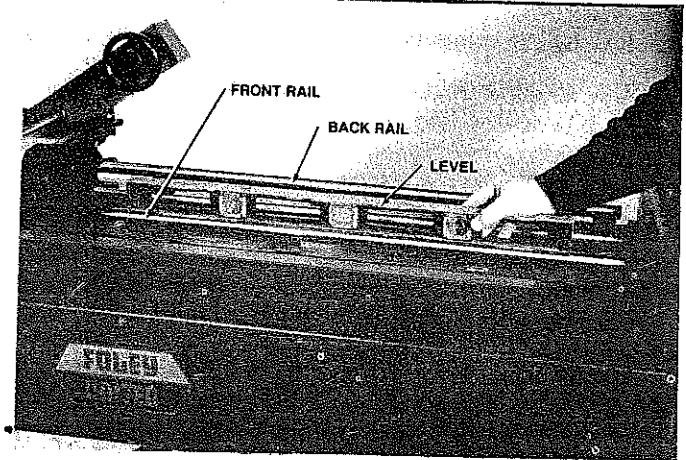

FIG. 3

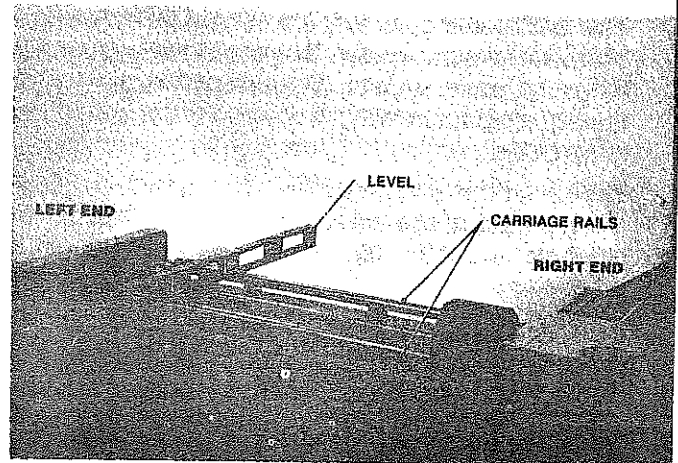

FIG. 4

ASSEMBLY INSTRUCTIONS

INSTALL REEL ELEVATOR

Bolt the left and right end frames to the top and bottom mounting brackets already attached to the end panels (see FIG. 5) using four (4) 3/8-16 x 3/4" hex head cap screws, lockwashers and nuts. Bolt gussets loosely to the overhead channel, which is installed with the pulleys on top, using four (4) 3/8-16 x 3/4" long hex head screws, lockwashers and nuts. Lift overhead channel into position and bolt to end frames using (4) 3/8-16 x 3/4" long hex head screws, lockwashers and nuts. Align and securely tighten all nuts. Attach winch to the left end (when standing in the rear of the machine) of the end frame with the handle post facing out with two (2) 3/8-16 x 3/4" long hex head cap screws and self locking nuts. (See FIG. 6A) Mount the handle to the winch, then place the spring over the handle post and secure with the 1/2" selflocking nut.

Thread cable through the top middle hole in the channel and over both pulleys. (See FIG. 6) Now loosen the cable clamp bolt inside of the winch drum and insert cable so that both sides of the clamp holds the cable. Securely tighten clamp bolt. Hold cable to the opposite side of the clamp in the drum and wind up excess over this cable, as an additional safety factor to prevent any slippage.

Cable is reeled up by rotating handle in a clockwise direction, as its reeled up it makes a clicking sound. The spring loaded handle actuates a brake when handle is released.

NOTE: Read separate directions on winch operation and maintenance.

Place spreader bar with chains and hooks onto cable hook.

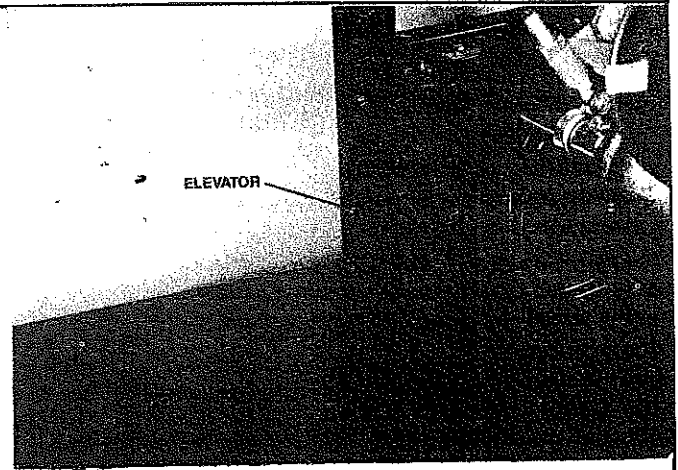

FIG. 5

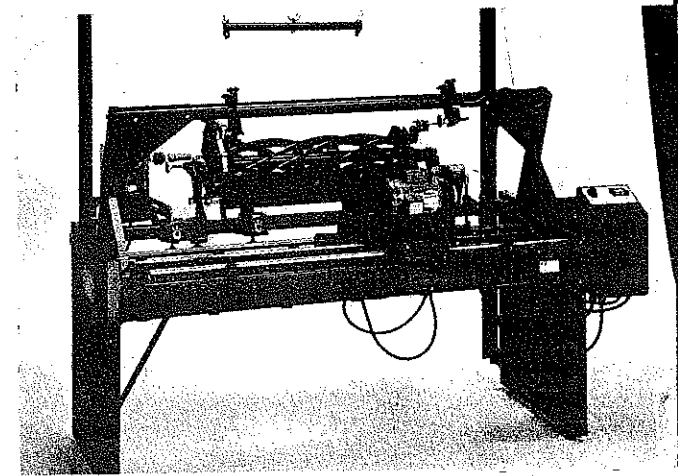

FIG. 6

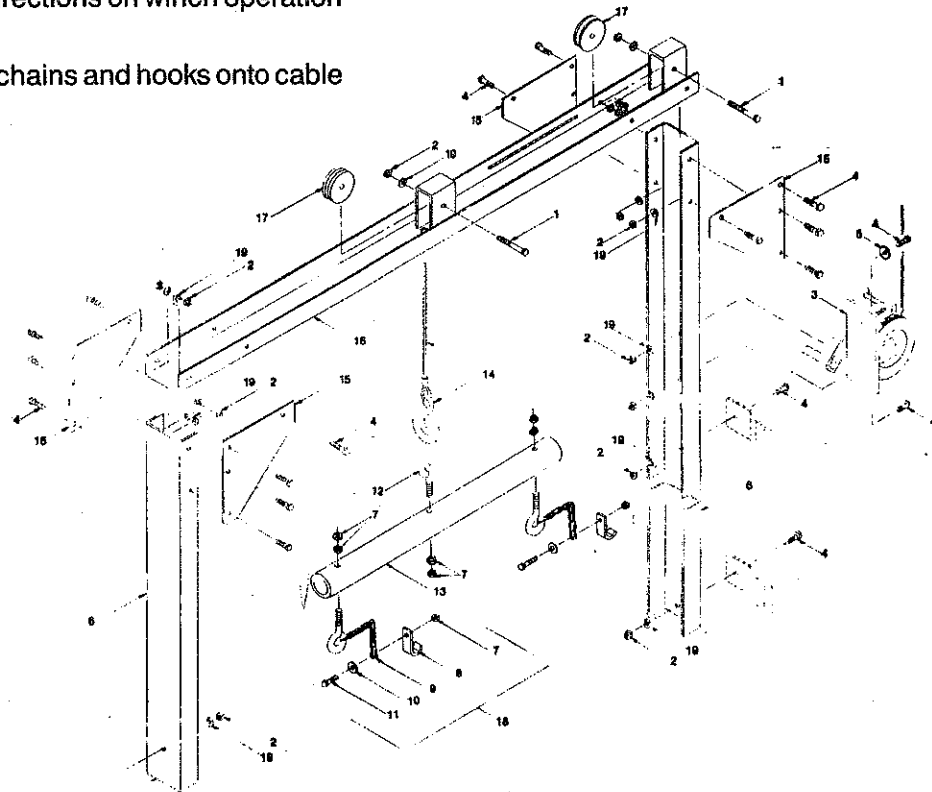

FIG. 6A

ASSEMBLY INSTRUCTIONS

INSTALL OVERHEAD SUPPORT

Install the left and right hand overhead support arms to the base panels using 3/8-16 x 3/4" hex head bolts and lock washers.

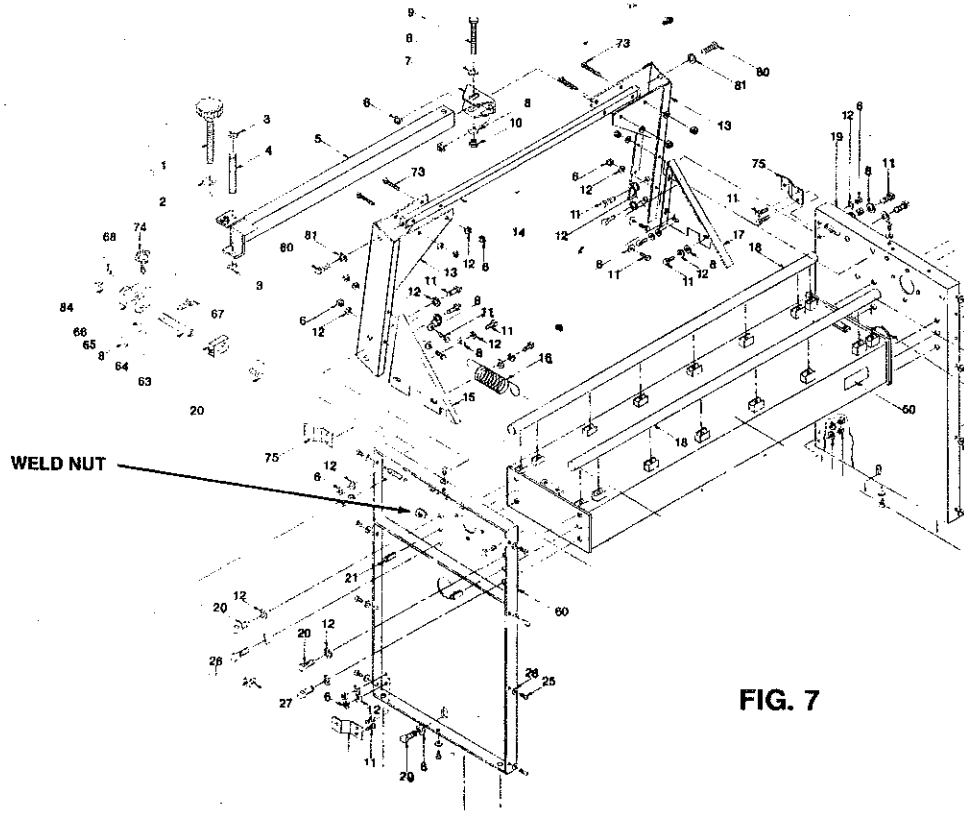

FIG. 7

NOTE: There are welded nuts already in place on the inside of the side panels to accomplish this installation.

Now install the square overhead bar onto the support arms and secure at each end with the 1/2-13 x 3/4" long hex head bolts and lockwashers. Bolt corner gussets to overhead bar using (4) four 3/8-16 x 3/4" long hex head bolts, split washers and nuts. Attach the triangular base support to the end panels and the support arms using 3/8-16 x 3/4" long hex head bolts, flat and lockwashers.

NOTE: There are welded nuts already in place inside the side panels to accomplish this installation. (See FIG. 7)

Hold the bottom portion of the overhead bar clamp in place as shown and attach the top portion by using the four (4) 3/8-16 x 3-1/4" long threaded knob assembly bolts with hand knobs. See page 56 Exploded View.

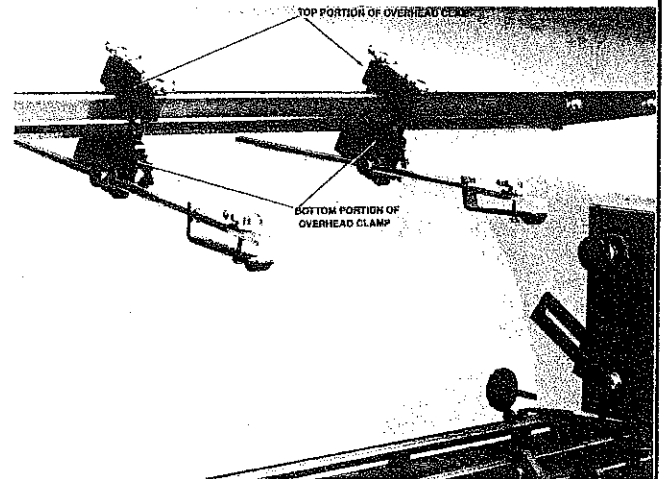

FIG. 8

ASSEMBLY INSTRUCTIONS

INSTALL GRINDER HEAD ASSEMBLY

Place the grinder motor assembly onto the motor base slide with the grinding wheel towards the rear of the machine. Align the two dimples in the motor plate with the two square headed cone end set screws in the motor base slide. Carefully center the grinding motor assembly so that it is equally spaced between the two adjusting arm locks. (See FIG. 10) Securely tighten the two square headed set screws making sure that the grinding motor assembly can pivot freely, then tighten the hex nuts on the pivot screws to lock in place.

NOTE: To make sure the set screws are properly tightened, lift grinding wheel motor up and check that there is no side play in the assembly. If movement is detected retighten set screws.



CAUTION: Movement in the area will cause a poor quality grind.

Install the feed screw into the motor plate casting until the motor is raised approximately 2" from the top of the plate. (See FIG. 10)

Place the 3/4" spacer and flat washer onto the threaded knob and insert through the adjusting arms and screw into the motor plate casting securely. (See FIG. 10)

Remove cord retainer clip from the front of the carriage base casting, thread the cord over the center brace on the underside of main base and through cord hole on the right side end panel. Plug cord into the control panel outlet labeled grinding wheel motor. See control panel instructions on FIG. 16. Pull all cord slack from the control box back to carriage assembly. (See FIG. 10A)

Now traverse grinding carriage assembly the maximum distance in both directions to make sure there is sufficient slack in both power cords. Then secure both the limit switch cord and the grinding motor cord under the main frame to the tie down mount with the cord tie provided. (See FIG. 10A) Now place cord in the retaining clip and attach to the right hand side of the base plate leaving enough slack so the grinding wheel assembly can be moved fully forward.

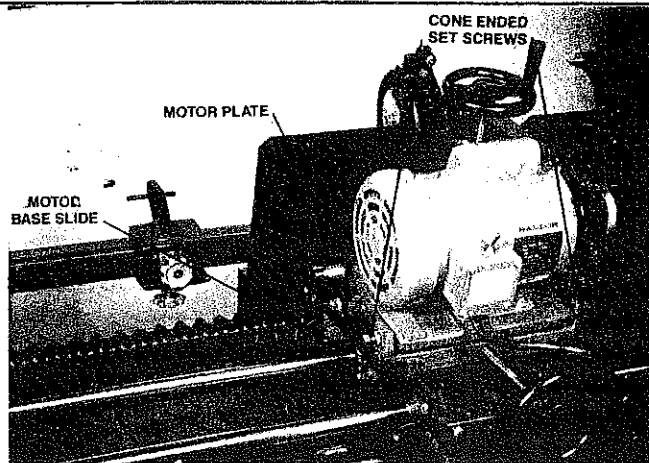

FIG. 9

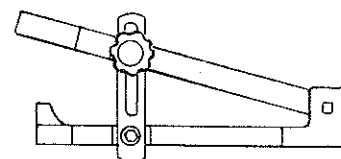
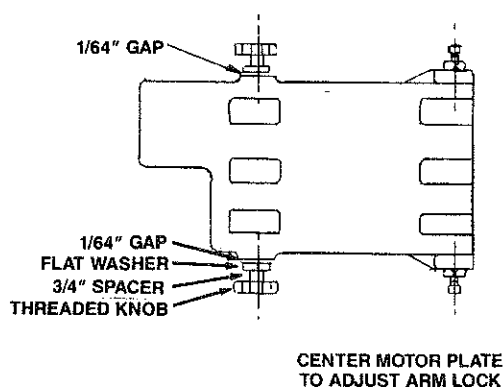

FIG. 10

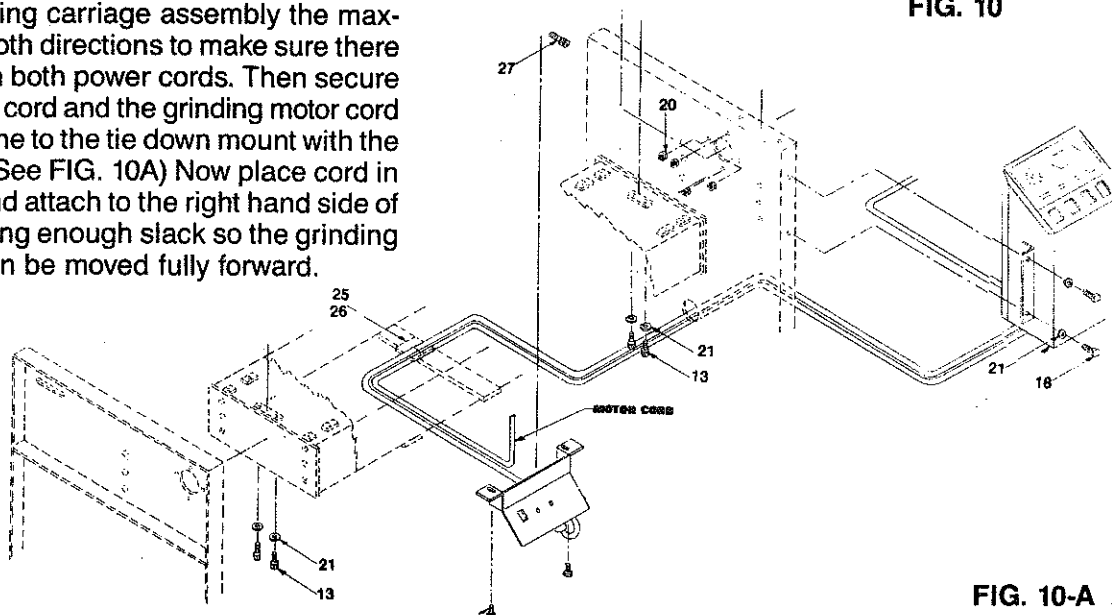

FIG. 10-A

ASSEMBLY INSTRUCTIONS

INSTALL SPLASH GUARD & DUST BAG

You are provided with a bag and hose clamp to mount to the bottom side of the dust collector chute.

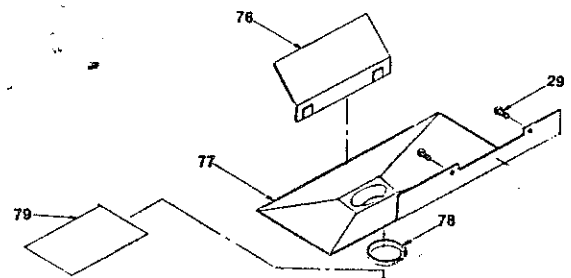

FIG. 11

INSTALL SPIN DRIVE UNIT

Place the spin drive mounting bracket with scissor bars onto the right hand side of the square mounting bar when facing the back of the machine. (See FIG. 13) The two (2) washers on one of the scissor bars should be in the rear position. Now attach the spin drive unit to the scissor parts using the 1/2-13 x 1-1/2" long hex head cap screw, flat washer and lockwasher.

Feed the power cord through the braces under the machine base and through the cord hole on the right hand side frame. Plug cord into the control panel outlet labeled "spin drive motor." See control panel instruction FIG. 16.

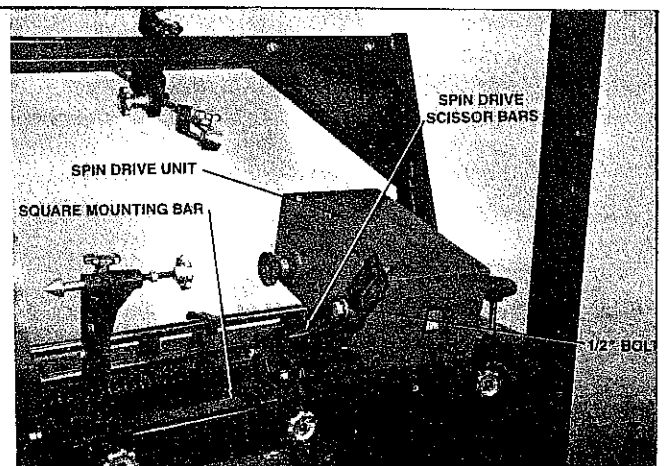

FIG. 13

ASSEMBLY INSTRUCTIONS

CONTROL PANEL

Remove control box from carton. Remove mounting screws in side frame and assemble control box to machine. Connect limit switch plug and motor plug to designated outlets.

The control panel has several switch controls identified as follows:

VARIABLE TRAVERSE SPEED CONTROL SWITCH: Adjusts grinding head traverse speed from 0-28 feet per minute.

GRINDING WHEEL/COOLANT CONTROL SWITCH: Turns the grinding motor on and off.

SPIN DRIVE/ACCESSORY SWITCH: For spin drive unit - turns motor on and off.

MAIN POWER SWITCH: Shuts all control switches down. (FIG. 14 & 16)

MOTOR WIRING & GROUNDING INSTRUCTIONS

Your Model 3096 Grinder has been completely prewired at the factory, and no additional wiring is necessary. The Model 3096 uses a standard 115V current, 15 AMP circuit. The wall outlet should be grounded and look like the outlet shown in FIG. 17.

GROUNDING INSTRUCTIONS

In the event of a malfunction or breakdown, grounding provides a path of least resistance for electrical current to reduce the risk of electrical shock. This tool is equipped with an electrical cord having an equipment grounding conductor and a grounding plug. The plug must be plugged into the machine outlet that is properly installed and grounded in accordance with all local codes and ordinances.

Before plugging in your machine, make sure it will be connected to a supply circuit protected by a properly sized circuit breaker or fuse.

Do not modify the plug provided—if it will not fit the outlet, have the proper outlet and circuit installed by a qualified electrician.



Always properly electrical ground your machine. An improper connection can cause an electrical shock. If unsure of the proper electrical grounding procedure, contact a qualified electrician.

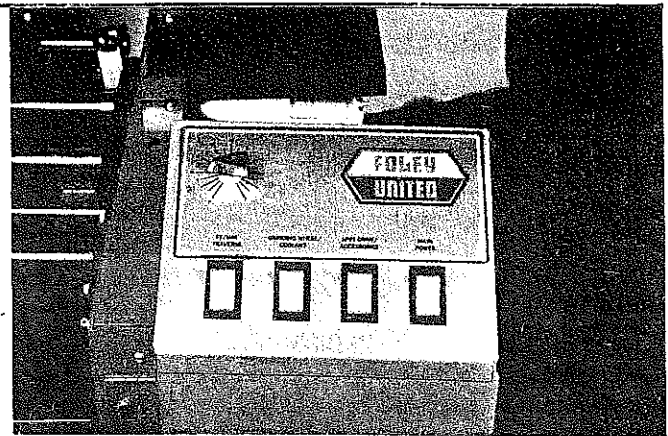
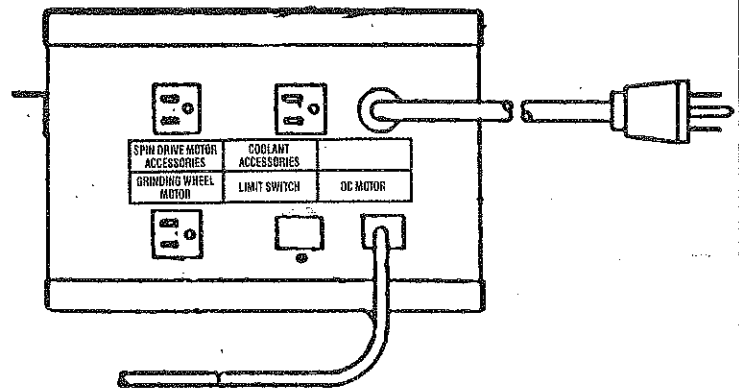
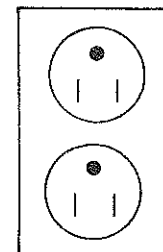

FIG. 14



BOTTOM OF CONTROL BOX

FIG. 16



115V 15 AMP CIRCUIT
NEMA 5-15R

FIG. 17

ASSEMBLY INSTRUCTIONS

SET UP GAUGE ASSEMBLY

Loosen key screw in set up gauge casting and insert dial indicator as pictured. Retighten hex set screw so that dial indicator cannot move or twist in the casting.



CAUTION: Do not overtighten so that the plunger does not actuate.

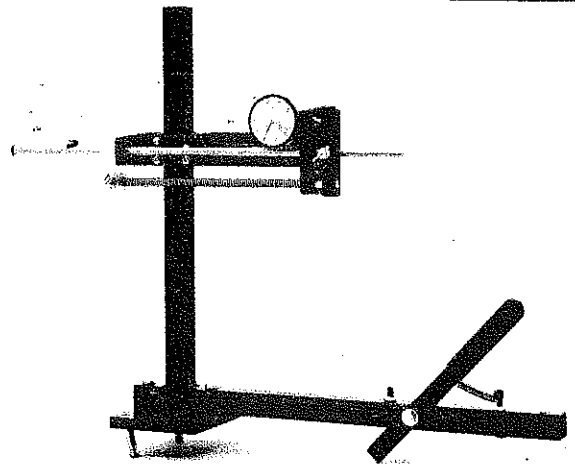

FIG. 18

OPERATING SAFETY INSTRUCTIONS



In addition to the general safety instructions located on page 2, observe and follow these safety points for operation of the Accu-Spin Reel Grinder.

1. Always use protective eye wear when operating the Accu-Spin.
2. Never use a grinding wheel other than the grinding wheels supplied by the manufacturer and listed in the parts list.
3. If guide finger is left on grinding head when spin grinding, make sure there is proper clearance by rotating reel by hand prior to setting up spin drive mechanism
4. When the grinder is operating, keep clear of all moving parts, especially the spinning reel.

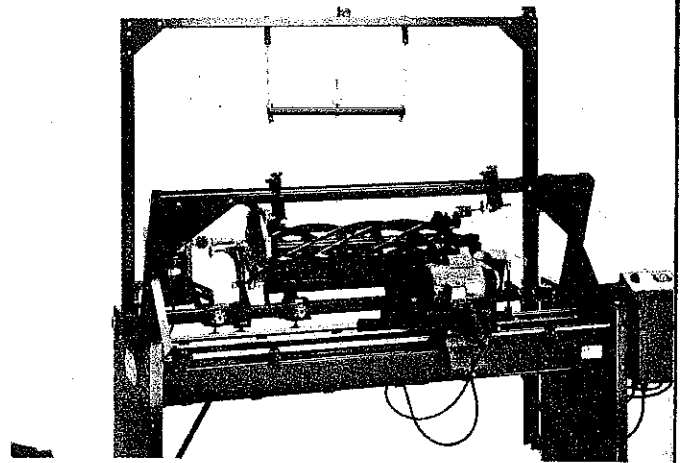
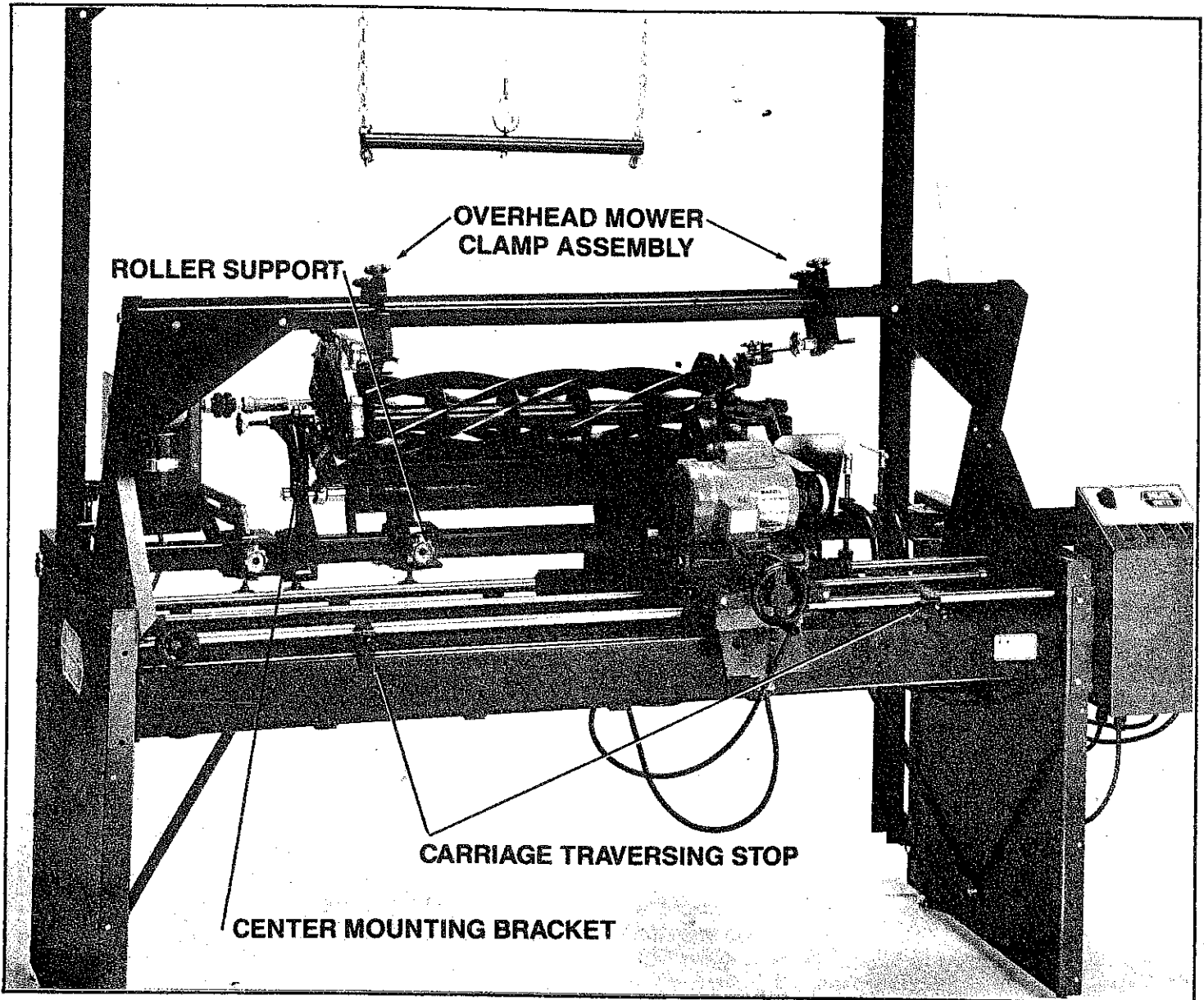

FIG. 19

GETTING TO KNOW YOUR GRINDER



SPECIFICATIONS

Overall Width	86"
Overall Height	78"
Overall Depth	42"
Weight	880 lbs.
Base Construction	Heavy Duty Welded Base
Carriage Rails	Precision Ground, Hardened Steel
Grinder	1/2 HP, 3450 RPM
Elevator	400 lb. capacity
Auto Spin	175 RPM
Auto Traverse	Overload Protected, No Thread Roller Drive

GETTING TO KNOW YOUR GRINDER

GETTING TO KNOW YOUR MACHINE

The following is a brief explanation of those machine components you will be using when setting up reels to grind on your new 3096 Accu-Spin Grinder. You should familiarize yourself with each part as this grinder has been engineered to spin and relief grind almost every type and make of reel mowers available today and adjustment of the various fixtures will be necessary for different types of reels.

OVERHEAD MOWER CLAMP ASSEMBLY

The overhead mower clamp assembly consists of two (2), two piece rectangular bar clamps, which also contains an adjustable holding fixture into which is placed the mower clamps. These clamps will always be positioned on the overhead square bar as shown in the adjacent exploded view. They are designed to lock into place and not move during the grinding procedure. Included are two sizes of clamp lips; normally the smaller size will be used. (FIG. 30)

REEL HUB SUPPORT

The reel hub support consists of a lower mounting bracket that fits over the square tooling mounting bar and two (2) threaded locking screws. Attached to this is the upper "V" bracket that cradles the reel hub when in position. There are three (3) vertical adjustments on this fixture, but it will normally be used in the upper two hole position. (FIG. 31)

These brackets can be mounted on the square mounting bar either forward or backwards, but the normal position will be with the "V" centered over the bar or with the offset facing the back of the machine. Near the top of the "V" bracket are two (2) long set screws that are used to attach the hold down clamps.

CENTERS MOUNTING BRACKETS

The centers mounting brackets also consist of a lower portion that fits on the square mounting bar and a stationary center fixture and an adjustable centering fixture. The stationary fixture will normally be used on the left hand side of the mounting bar when facing the reel loading position. There are three (3) vertical positions for the center fixture, but they will normally be used in the middle position as shown in the picture. These brackets should be mounted to the square bar so that the centering pins are facing the back of the machine and directly over square mounting bar. These centering fixtures are used on greens mowers or any reel that doesn't have a hub that can fit into the "V" bracket. (See FIG. 32)

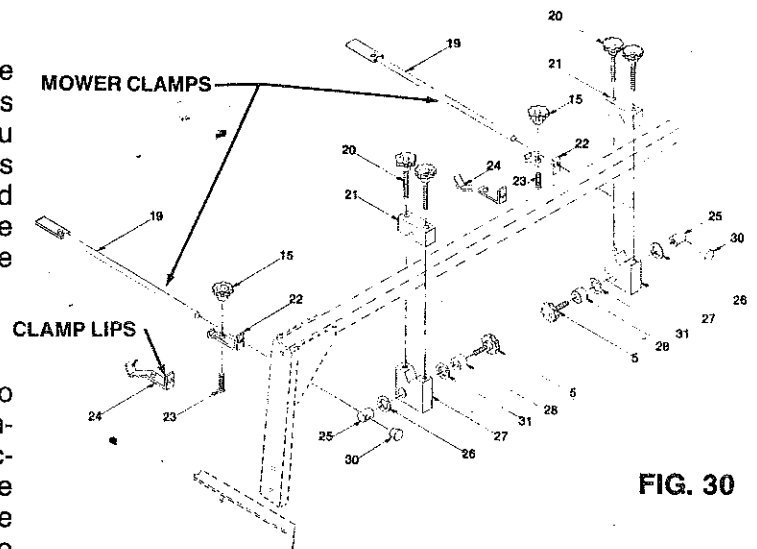

FIG. 30

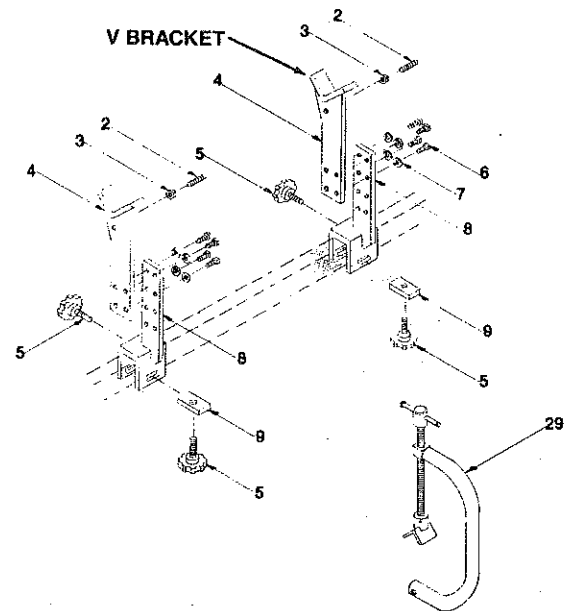

FIG. 31

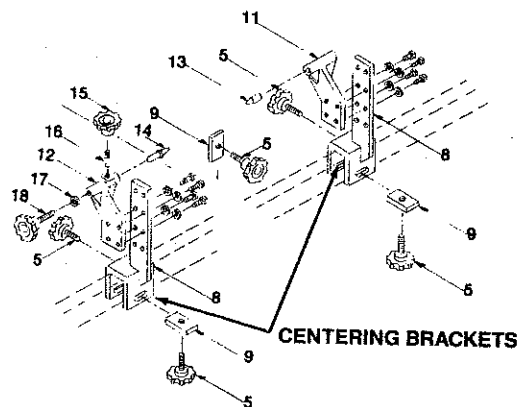

FIG. 32

VIEW FROM OPERATOR POSITION

GETTING TO KNOW YOUR GRINDER

ROLLER SUPPORTS

There are two (2) roller supports that are mounted to the square mounting bar so that the "V" faces the back of the machine as pictured. (See FIG. 33)

There are four long set screws on these brackets which are used to hold the extender plates when it is necessary to move mower roller back further to help expose the drive nut in the reel. These set screws will also be used to attach the holding clamps when reels are in position. (See FIG. 34)



It is essential that the reel is held securely in position when grinding. Any movement of the reel will result in poor sharpening.

REEL GUIDE FINGERS

There are two reel guide fingers included with your grinder. They are used to relief grind reels after they have been spun ground. The wider factory mounted finger will normally be used, but on reels where there is not enough room between blades the stamped narrow finger will have to be used. (See FIG. 36A-36B)

On the factory installed finger the high point of the fixture must be positioned on the corner of the grinding wheel that is making contact with the reel when grinding. It might be necessary on reels that have a reverse spiral to readjust the support finger. When using the stamped thin finger it is necessary to dress the grinding wheel so that high point of the finger is positioned where the grinding wheel makes contact with the reel. (See FIG. 36A & 36B)

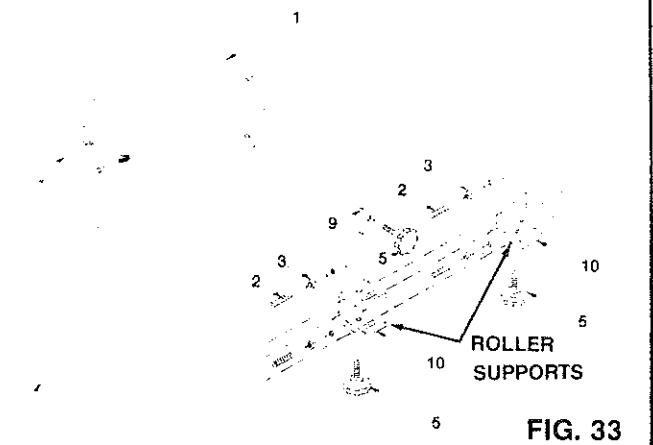

FIG. 33

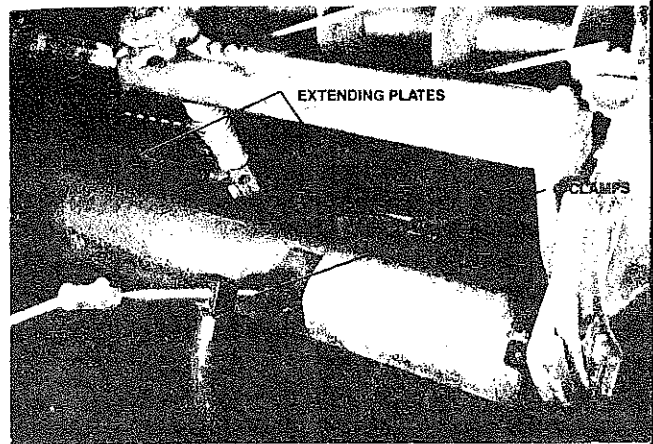

FIG. 34

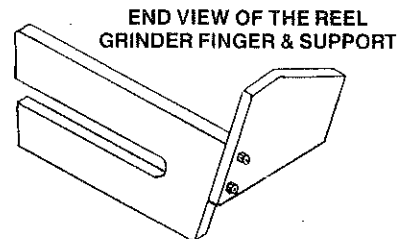

FIG. 35

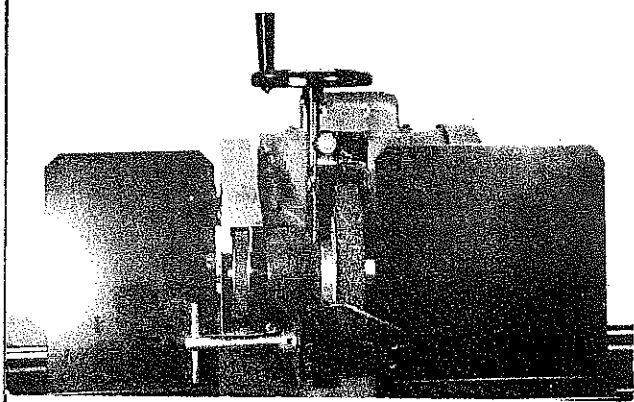

FIG. 36A

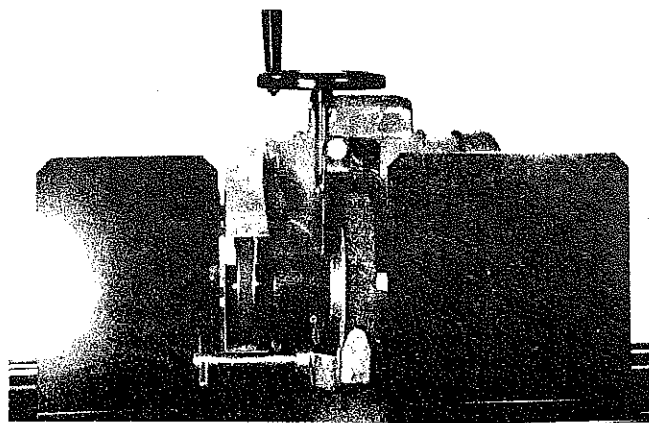

FIG. 36B

GETTING TO KNOW YOUR GRINDER

DRESSING STICK & OPTIONAL HAND DIAMOND DRESSER

The dressing stick is used to dress the grinding wheel when it loads up or glazes over. Normal spin grinding will dress the wheel automatically, but hand dressing could be necessary when relief grinding. The optional hand diamond dresser is available when excessive dressing is necessary. (See FIG. 37)

CARRIAGE TRAVERSING STOPS

The carriage traversing stops can be mounted anywhere along the front rail to restrict the amount of travel of the grinding wheel assembly. They should be mounted so that locking screws face the operator. (See FIG. 38)

TRAVERSE ACTUATOR RELEASING SCREW

It is possible to release the grinding motor assembly so that it can be moved by hand. To do this simply insert the 10" "L" handled allen wrench through the slot in the front of the motor base slide and into the hex head screw located in the middle of the traversing actuator. (See FIG. 39)

By turning the screw in until the washer touches two (2) cap screws. Then turn 1/2 turn clockwise further. This will release tension on the actuator and the carriage can be moved easily by hand. To reset actuator simply turn screw 1/2 turn plus counter-clockwise so the washer does not touch the two (2) cap screws. This will reset tension on actuator. (See FIG. 39)

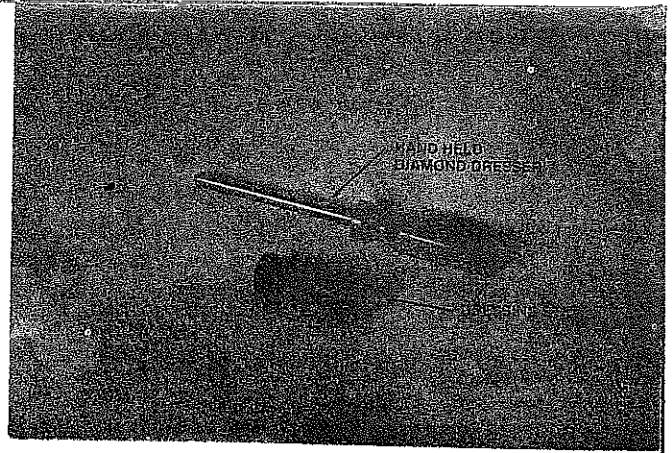

FIG. 37

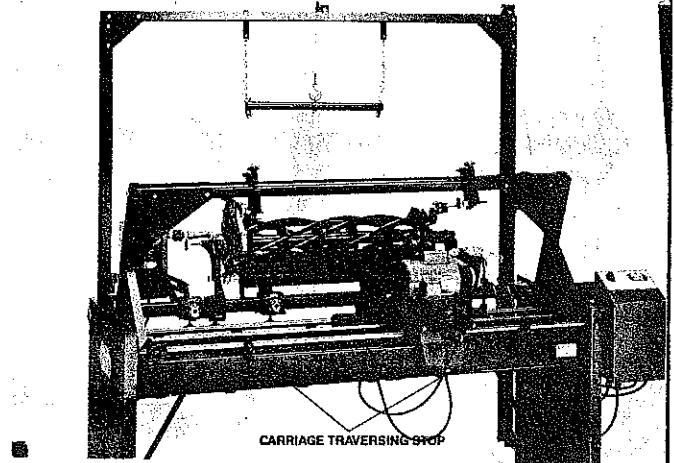

FIG. 38

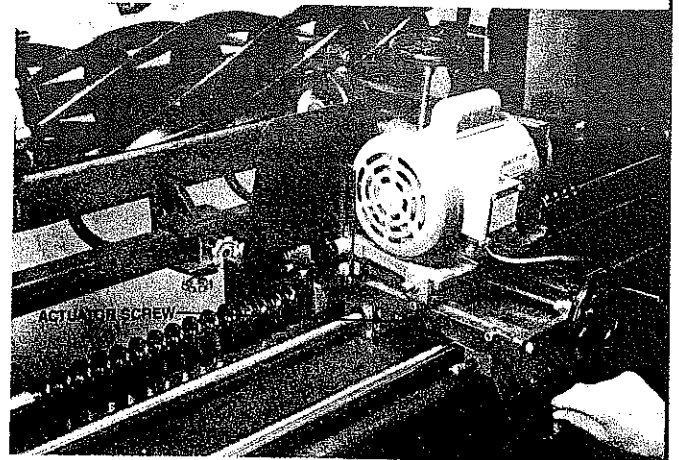
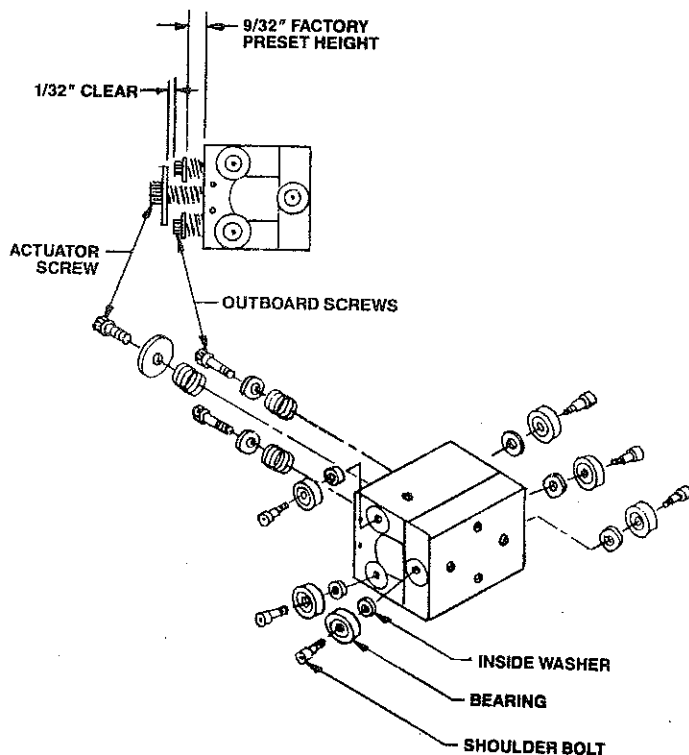

FIG. 39

NOTES

This page left intentionally blank for note taking.

OPERATING INSTRUCTIONS

PREPARE MOWER FOR SHARPENING

Preparation of the reel prior to sharpening. It is recommended that the reel to be sharpened is thoroughly cleaned. Remove wheels and bed bar, if possible, from the reel. All bed knives should be ground when reels are sharpened. Inspect, adjust and/or replace any bearings. Make sure reel bearings are adjusted properly so the reel turns easily by hand.



CAUTION: Reels with excess tension on the bearings will be extremely difficult to spin grind and could cause damage to the reel or the spin drive mechanism on your grinder.



CAUTION: Reels ground with bearings which have wear and/or free play will not hold diameter, cone shape or straightness specifications.

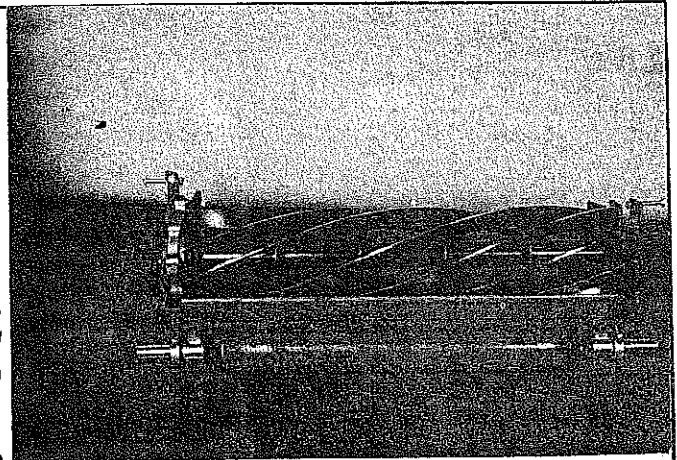

FIG. 40

INITIAL SET UP OF REEL SUPPORTS

- A. On Fairway mowers with exposed hubs, you will use the "V" reel hub supports. Normally they will be positioned in the top two holes of the lower supports with the offset "V" facing the rear of the machine. (See FIG. 41)
- B. With Fairway mowers without exposed hubs or normally all greens mowers, you will use the centering mounting brackets. They are mounted with the offset facing the back of the machine and mounted to the center holes in the lower support (See FIG. 42)

NOTE: Because of the many different reels available the exact position of either the "V" bracket or the centers bracket to the lower support can be adjusted to three different height settings. Further explanations of these setups will be discussed in the exact reel set up instruction sheets available for common style mower units.

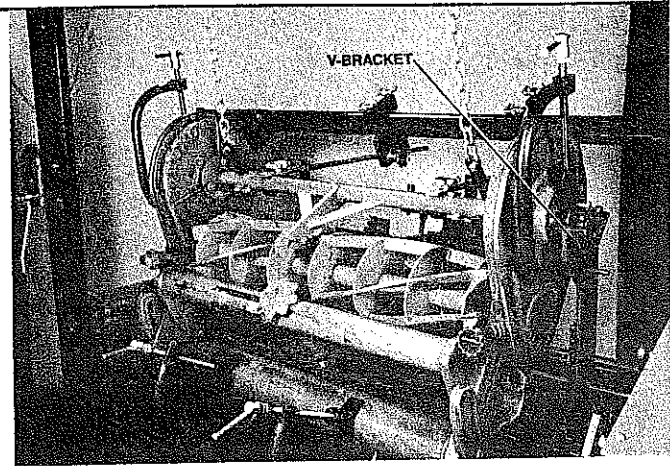

FIG. 41

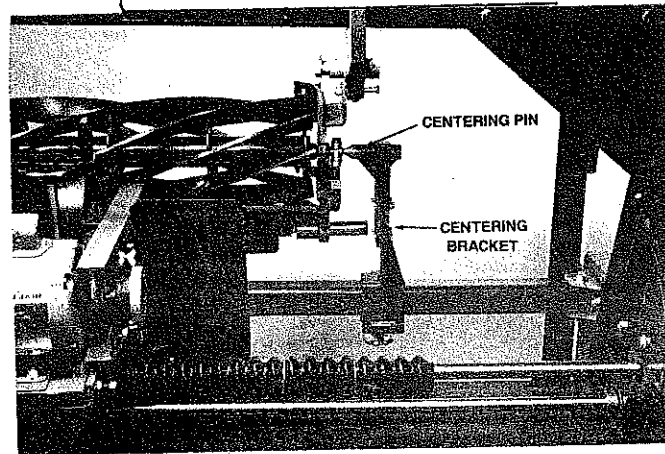

FIG. 42

OPERATING INSTRUCTIONS

INITIAL SET UP OF SUPPORTS (Continued) "V" BRACKET SET UP

On reels with exposed hubs where you will be using the "V" brackets, measure the distance from the outside of the hubs and subtract one inch. Determine the middle of the square mounting bracket, by use of the winch cable. Then place a "V" bracket 1/2 that distance on the left side of the mounting bar and securely fasten - use both locking knobs.

NOTE: Tighten the side locking knob first so the bracket is forced against mounting bar. Then tighten the bottom bracket. (See FIG. 43)

Now place a "V" bracket on the right side of the mounting bar the same distance from the centerpoint, but loosely attach as it might have to be moved when reel is lifted into place.

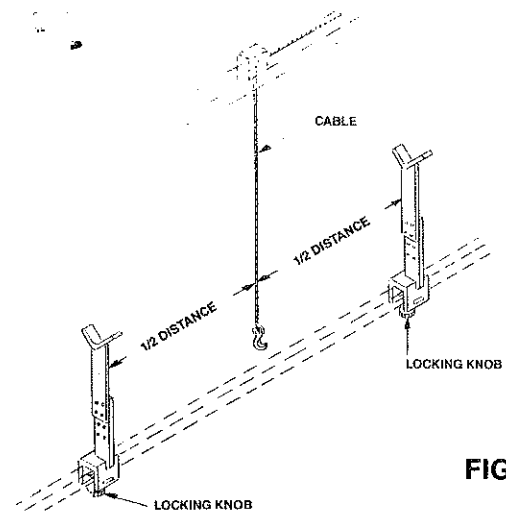

FIG. 43

CENTERS BRACKET SET UP

When mounting reels with no exposed hubs, measure the outside distance of the mower frame. Using the centerpoint of the square mounting bracket position the fixed centering bracket 1/2 that distance on the left side and securely fasten.

Then place the adjustable centering bracket that distance plus 1/4" on the right side of the mounting bar and loosely fasten. It may be necessary to move this bracket when lifting reel into place even though it can be adjusted. The adjusting cone should be retracted as far as possible as it will be easier to secure reels when in place.

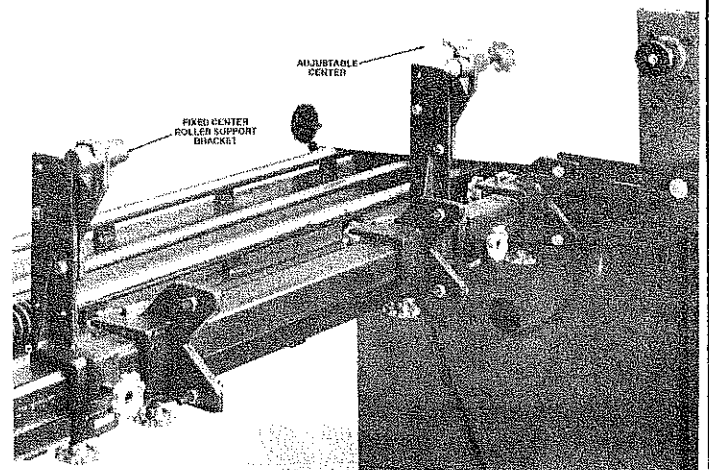

FIG. 44



Firmly tighten all locking knobs before grinding. Any looseness will adversely affect grinding quality.

INITIAL SETUP OF ROLLER SUPPORTS

The roller support brackets should be placed 6" to 8" inside the reel supports with the "V" facing the back of the machine and securely fastened with both locking knobs. (See FIG. 45)



Firmly tighten all locking knobs before grinding. Any looseness will adversely affect grinding quality.

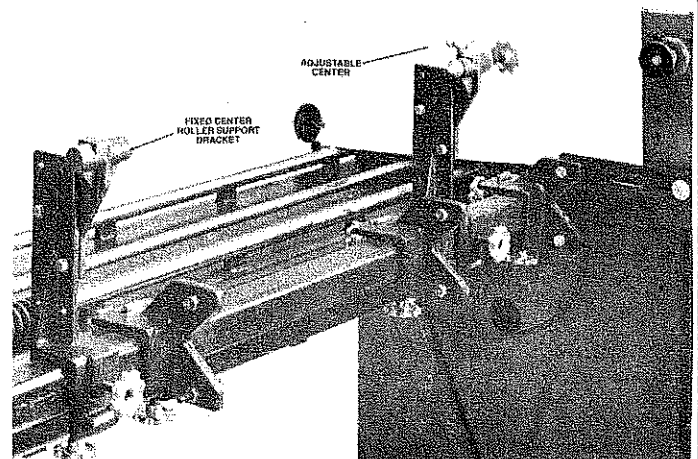

FIG. 45

OPERATING INSTRUCTIONS

LIFTING REEL INTO POSITION WHEN USING THE "V" MOUNTING BRACKETS

Position the reel behind the grinder so the front of the reel faces the front of the grinder. Hook the reel elevator spreader bar onto the reel and with the left hand slowly raise the reel into position guiding it with your right hand.

NOTE: The reel elevator winch has a spring loaded handle that automatically actuates a brake when the handle is released. The winch clicks when raising and the handle must be turned to lower.

When the hub of the reel has been raised above the top of the "V" bracket slowly position the left side of the reel into the bracket and lower until you make contact with the bracket.

Now reposition the right "V" bracket if necessary and lower the reel completely into both brackets. Securely tighten the right bracket using both locking knobs. (See FIG. 46)

NOTE: On reels that have a square or hexagon shaped hub make sure that the flat surface of the hub is against the flat machined surface of the "V" bracket.

LIFTING REEL INTO POSITION WHEN USING CENTERS BRACKETS

Position reel as when using the "V" brackets and attach elevator spreader bar. Slowly raise the reel into position and insert the fixed centering pin into a predetermined hole in the reel frame. While holding the reel firmly against the fixed centering pin, raise or lower the reel so the adjustable centering bracket can be moved and the cone inserted in a corresponding hole in the opposite side of reel frame. Now tighten both locking knobs on the adjustable bracket and then tighten the adjustable centering cone into the reel and secure with the centering pin locking knob. (See Fig. 47)

NOTE: Make sure that the spin drive can be attached to the reel at this time. You are furnished with two extension plates that can be mounted to the roller braces that will move the reel 2" further back if more clearance is necessary. (See FIG. 48)



Firmly tighten all locking knobs before grinding. Any looseness will adversely affect grinding quality.

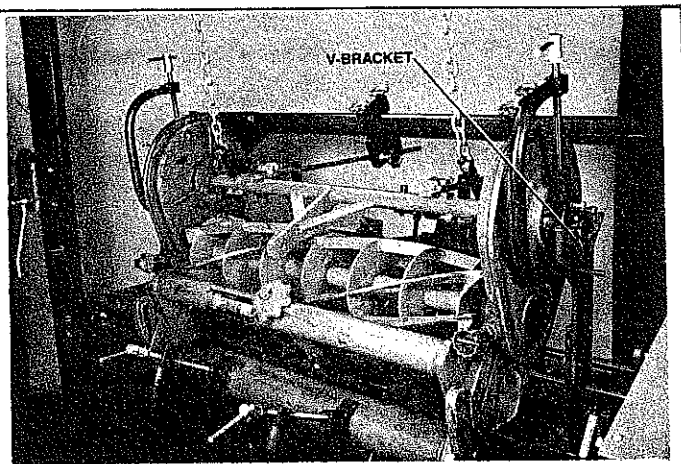

FIG. 46

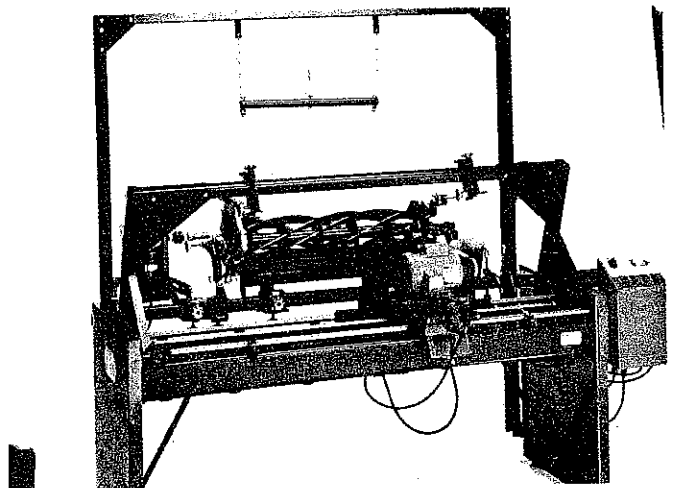

FIG. 47

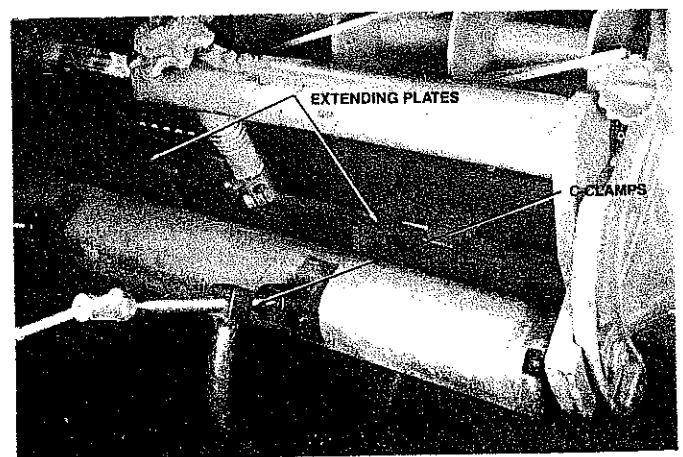

FIG. 48

OPERATING INSTRUCTIONS

SECURING ROLLER TO ROLLER BRACES

Slide two (2) clamps on the long socket head set screws located on the roller braces.

NOTE: There are two (2) positions that you can use to make sure the "V" bracket on clamp is centered on the roller.

Now swing clamp into position and tighten until enough pressure is exerted on roller so there can be no movement while grinding. (See FIG. 49)

If extender plates are necessary to move reel back further, simply pull reel back out of the way and slide extender plate onto both long socket head set screws.

CAUTION: Make sure that the elevator cable is attached to the reel and that some tension is on cable before pulling reel back.

Now slide clamp over appropriate socket head set screw and tension as before. It is not necessary to bolt down either the extender plates or the clamps when in use.



Firmly tighten all locking knobs before grinding. Any looseness will adversely affect grinding quality.

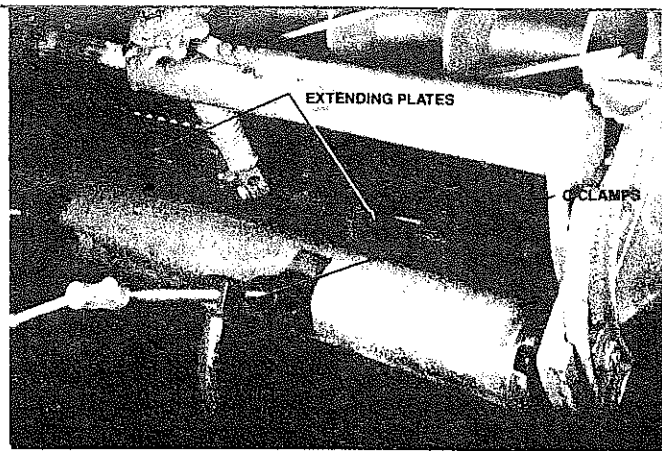

FIG. 49

ATTACHING THE OVERHEAD CLAMPING ARMS

You are furnished two sizes of clamping lips, determine which size is appropriate for the reel you are grinding. Normally this will be the smaller size.

Loosen the two screw handles on each overhead clamp and move them to where the overhead clamp rods with clamping lips can be attached to the reel. This can be a mounting bolt on the reel or the reel cross bar. Tighten the clamping lips to the mower, then securely tighten the screw handles on each overhead clamp. (See FIG. 51)

NOTE: Do not tighten the adjustable holding fixture where rods are inserted into the lower part of the clamp until reel has been aligned. (See FIG. 52)



Firmly tighten all locking knobs before grinding. Any looseness will adversely affect grinding quality.



FIG. 51

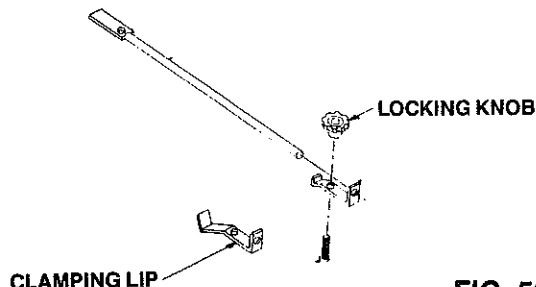

FIG. 52

OPERATING INSTRUCTIONS

ATTACHING THE SPIN DRIVE UNIT TO THE REEL

When spin grinding, the reel should turn in the same direction as the grinding wheel. (See FIG. 83) The normal position for the spin drive unit is on the right side of the square mounting bar when viewing from the mowing unit loading position of the machine. In this position the reel will be mounted to the extended shaft on the spin drive unit. If the spin drive unit is placed on the left side the reel will be connected through the cut out hole in the spin drive unit. (See FIG. 53)

- A. Rubber Coupler: This is placed in the corresponding flange coupler already mounted in the spin drive shaft.
- B. Drive Coupler Adapter Assembly: This is mounted to the rubber coupler.
- C. Adapter Sleeve: This should be placed about 3/4" on the drive coupler adapter.
- D. Square Drive Shaft: This is inserted into the adapter sleeve and should be able to be moved approximately 2". It will be necessary to move this when attaching reel to spin drive unit. It is then inserted into any 1/2" square drive socket. (See FIG. 55)

NOTE: The 1/2" square drive socket that is placed on the reel when spin grinding is **NOT** included with the grinder. You must purchase this from an appropriate local supplier of tools.

By loosening the 1/2" bolt that holds the spin drive unit to the scissor bars you are able to move it to a variety of positions. The normal position for the mounting bracket will be with the "V" on back of the square mounting bar and the locking knobs facing the back of the machine. (See FIG. 56)

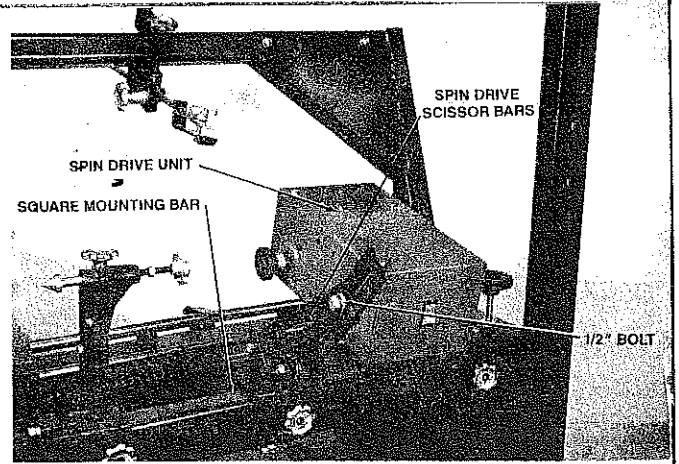

FIG. 53

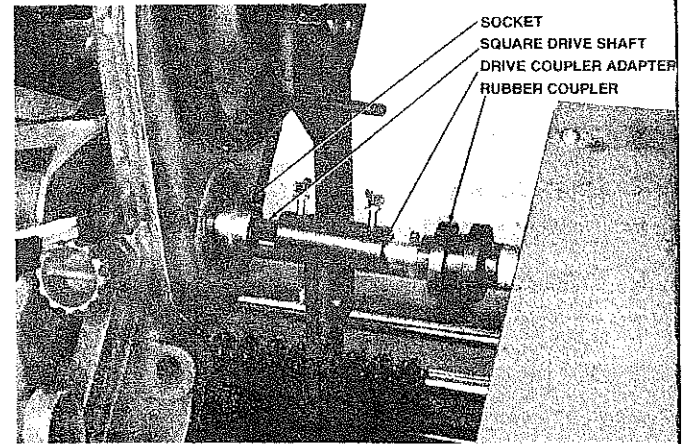

FIG. 54

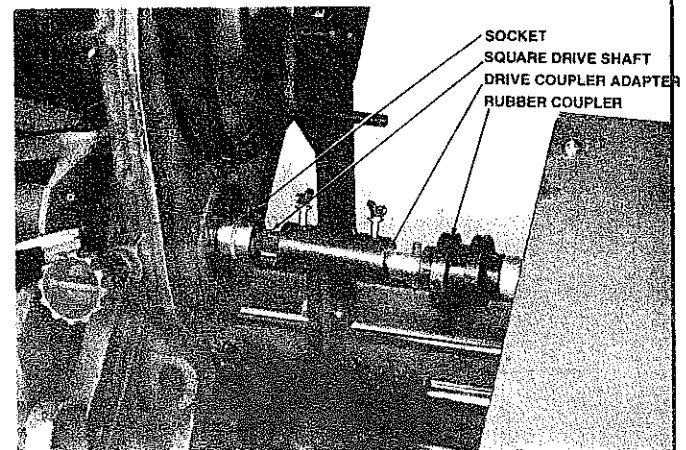

FIG. 55

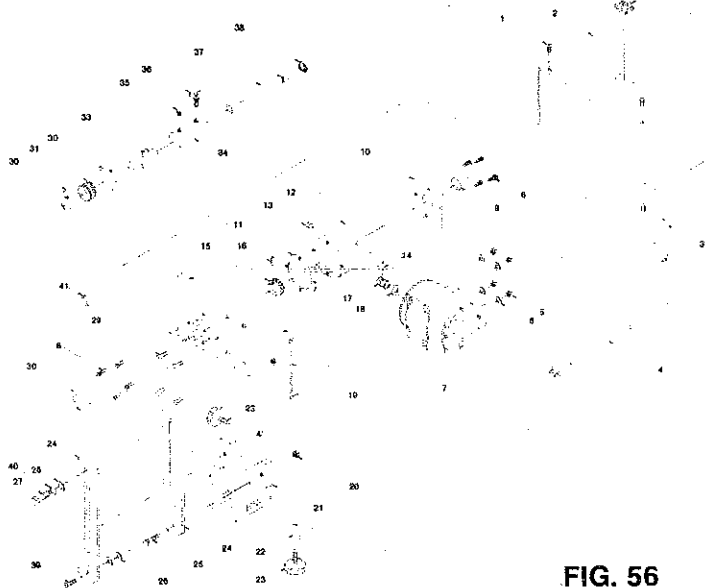

FIG. 56

OPERATING INSTRUCTIONS

The following procedure will make setting up spin drive unit easier.

- A. Move spin drive unit close to reel so that you can align the shaft on the spin drive with the drive nut on reel. Loosen the 1/2" bolt on the spin drive scissor bars to make the alignment adjustment and then tighten the 1/2" bolt. (See FIG. 57)
- B. Now slide the spin drive unit approximately 7" from the reel drive coupling point and securely fasten to the square mounting bar tightening both locking knobs.
- C. Place the proper 1/2" square drive socket on the reel drive nut and then insert the square drive shaft into the socket. Place the adapter sleeve over the drive shaft and insert the drive coupler adapter assembly into it. Finally place the rubber coupler onto the drive coupler adapter. (See FIG. 58)
- D. By holding the square drive shaft firmly into position with your left hand you will be able to move the other components to the right and insert the rubber coupler into the flange on the spin drive unit. When this is done tighten the wing nut on the adapter sleeve to hold all parts in place.
- E. Finally re-adjust the spin drive unit if it is not in alignment by loosening the scissors bars.

NOTE: It is not necessary to have perfect alignment but must be close enough so that the coupler remains engaged and that excess torque is not applied to the reel.

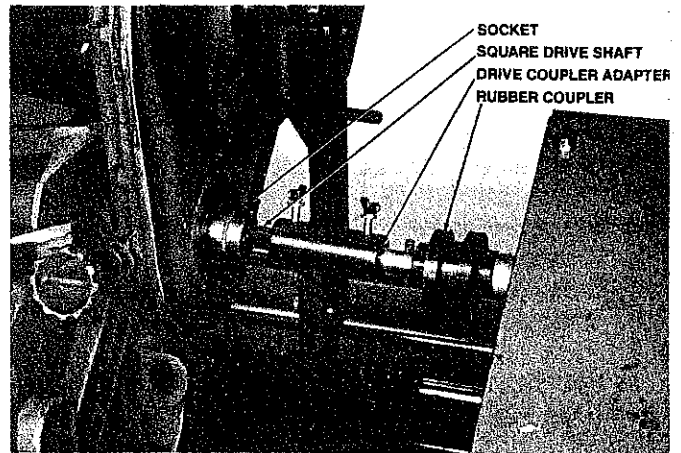
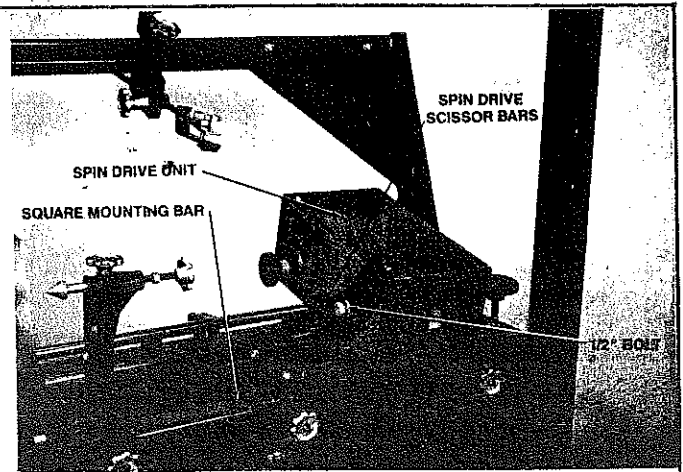

FIG. 58

OPERATING INSTRUCTIONS

REMOVING SPREADER BAR FROM REEL

Now remove the spreader bar and hooks from the reel. Place hooks over the top channel on the elevator and crank up excessive slack. (See FIG. 60)

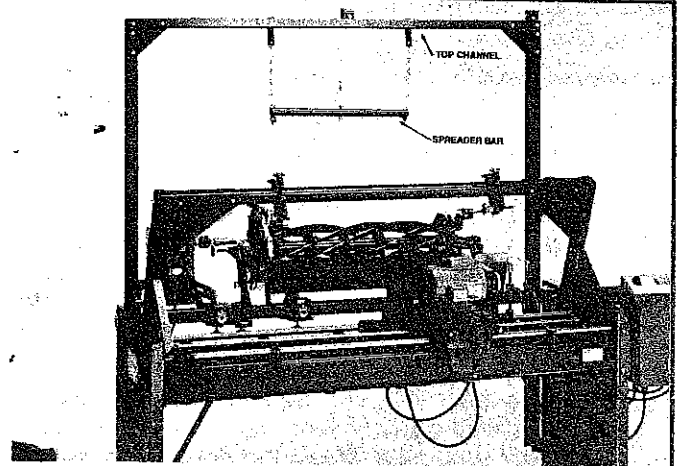

FIG. 60

DIAL INDICATOR SET UP FIXTURE

The dial indicator set up fixture is made up of the following components. (See FIG. 61-A)

1. Base plate with rail locating pins.
2. Base plate locking handle.
3. Vertical support bar.
4. Indicator slide casting.
5. Indicator rod.
6. Tension spring rod.
7. Back retainer plate.
8. Dial indicator with a .001 scale and .10 scale.

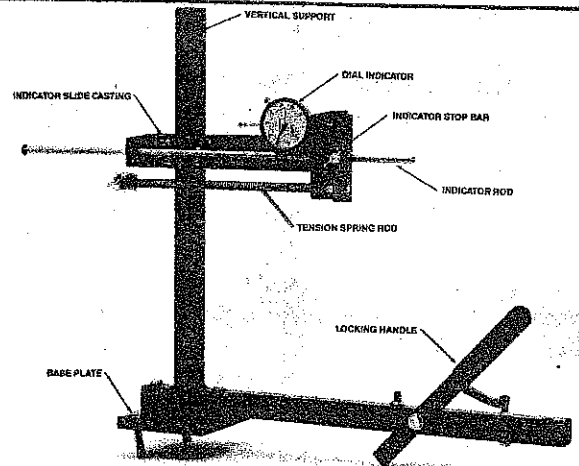

FIG. 61-A

GAGE SET UP MODIFICATION FOR USE ON THE MODEL 396 REEL GRINDER

Reference Information—See FIG. 61-B for the gage handle locking position to the traversing rails on your 3096 reel grinder.

GAGE SET UP MODIFICATION FOR USE ON THE MODEL 388 REEL GRINDER

If the gage is to be used on the Model 388 Reel Grinder, the spring loaded handle assembly must move back approximately 1.68" to the holes located on the base plate.

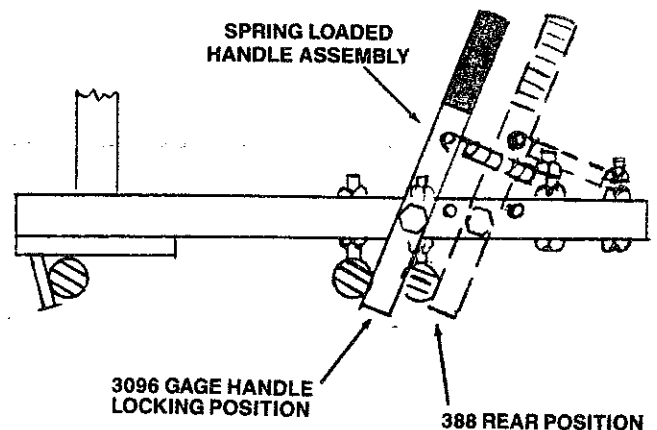

FIG. 61-B

OPERATING INSTRUCTIONS

REEL ALIGNMENT USING THE DIAL INDICATOR SET UP FIXTURE

- A. Position the grinding wheel assembly in the middle of 36" or wider reels and to one side of the grinder on smaller reels, so that you can touch both sides of the reel with set up fixture without moving the grinding wheel assembly from side to side. (See FIG. 63)
- B. Make sure overhead clamping rods are loose in their adjustment fixture so that the reel is free to move forward and backwards. (See FIG. 64)
- C. Loosen the two locking knobs on the pivot assembly on the left side of the square mounting bar so that it can be adjusted in both the vertical and horizontal plane. (See FIG. 65)

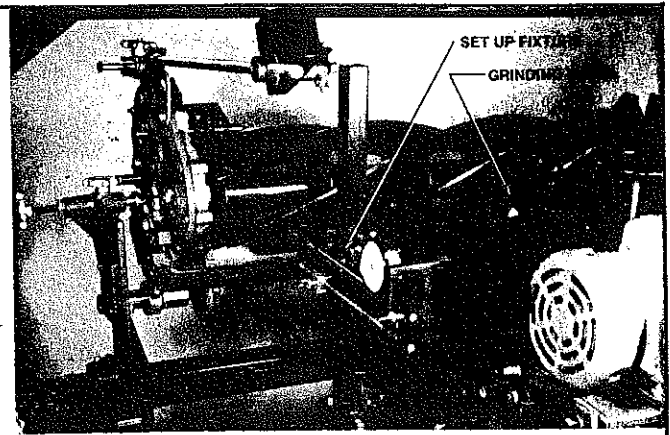

FIG. 63

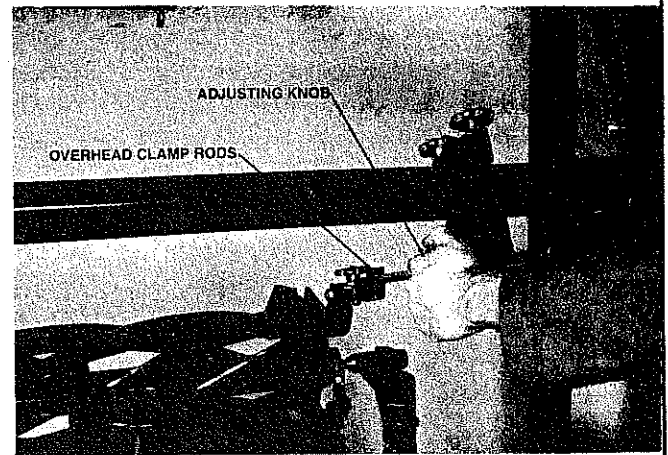

FIG. 64

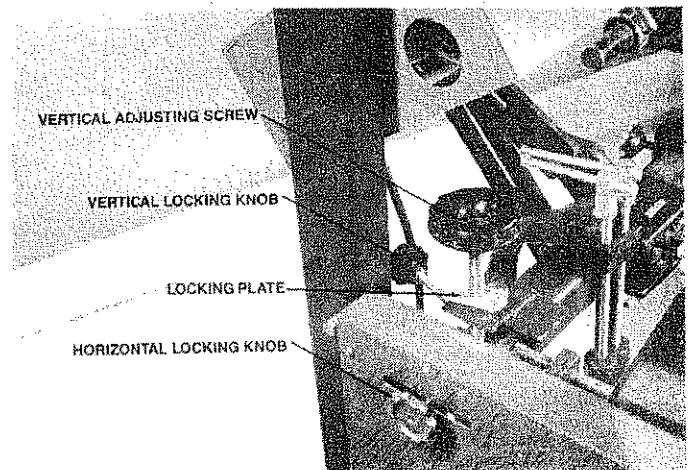

FIG. 65

OPERATING INSTRUCTIONS

ALIGNING REELS IN THE VERTICAL PARALLELISM PLANE

- A. Place the set up fixture approximately 2" from the right side of the reel and lock it to the front and back rails of the base.
- B. Raise the indicator slide casting on the vertical support so that the indicator rod can be extended over the center shaft of the reel. (See FIG. 66) Page 4 for parts description).
- C. With your left hand on the vertical column supporting the indicator slide loosen the locking knob and slowly lower the indicator slide until the alignment rod lightly touches the top of the reel center shaft. Then lock the fixture to this setting. (See FIG. 67)
- D. Now move the alignment fixture to the left side of the reel making sure to pull back on the alignment rod so it will clear reel as gage is moved from one position to the other. (See FIG. 68)
- E. If the left side is lower than the right, turn the vertical adjusting screw in the pivot assembly clockwise raising the mounting bar and the reel until the center shaft of the reel lightly touches the extended indicator rod. (See FIG. 70-A)

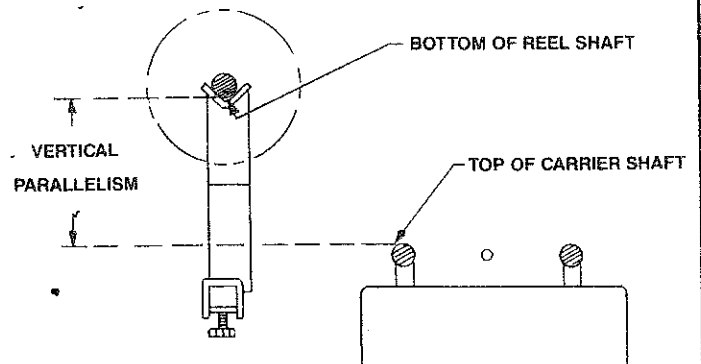

FIG. 66

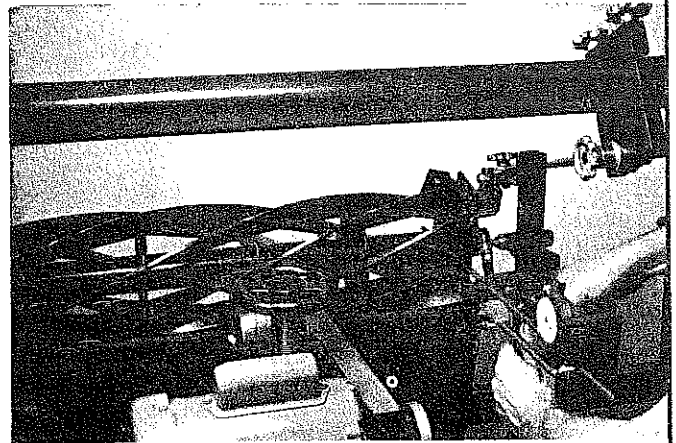

FIG. 67

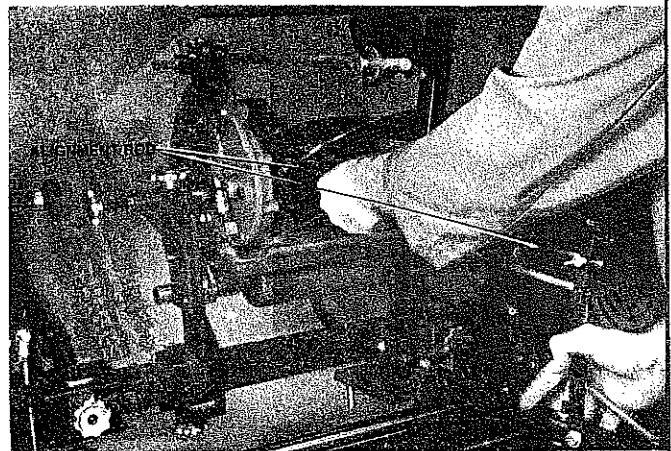

FIG. 68

OPERATING INSTRUCTIONS

VERTICAL ALIGNMENT—continued . . .

- F. Place a mark on the knob so you know where you are starting from. (See FIG. 70-A) Now turn the vertical adjusting screw 1-1/2 more revolutions. This 1-1/2 revolution is to compensate for the fact that as you adjust the left side, the right side is also moving at a ratioed amount. This should almost align your reel in the vertical parallelism plane. (See FIG. 70-A)
- G. Move the alignment fixture back to the right hand side of the reel and re-adjust the alignment rod so that it lightly touches the top of reel center shaft.
- H. Finally move it back to the left side to make sure the reel is in perfect vertical position. If not, move reel up or down so that it just touches alignment rod on both sides. When it does, no further alignment is necessary.
- I. If the left side of the reel is found to be higher than the right, lower the mounting bar and reel until alignment rod lightly touches the top of the reel center shaft and then turn the vertical adjusting screw an additional 1-1/2 revolutions. This 1-1/2 revolution is to compensate for the fact that as you adjust the left side, the right side is also moving at a ratioed amount. This should line reel up fairly accurately on both sides. Then continue with procedures found in "G" and "H."
- J. Now lock the vertical adjusting screw with both the locking plate and the locking knob in the back of the pivot assembly. (See FIG. 70-A)

NOTE: This alignment is not as critical as the horizontal plane, but care should be taken on all reel set ups. The accuracy need only to be approximately .010.

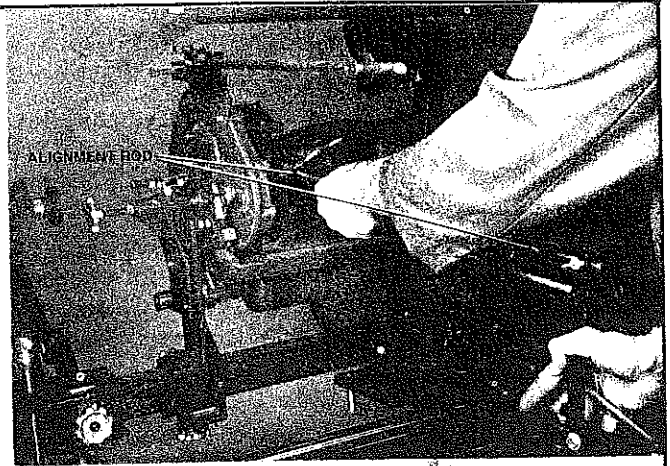

FIG. 69

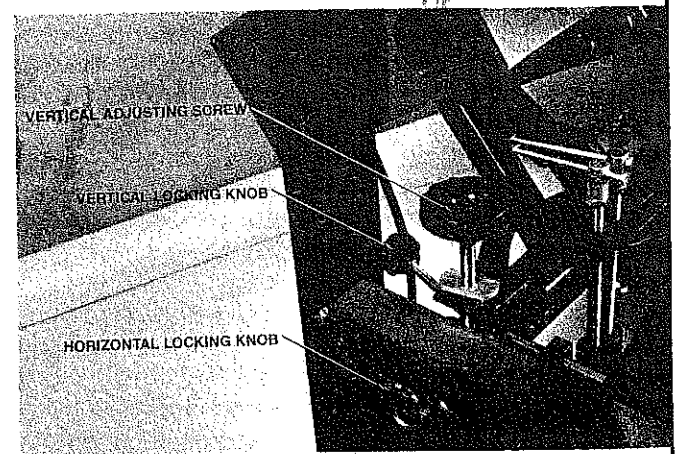

FIG. 70



Firmly tighten the vertical locking plate. Any looseness will adversely affect grind quality.

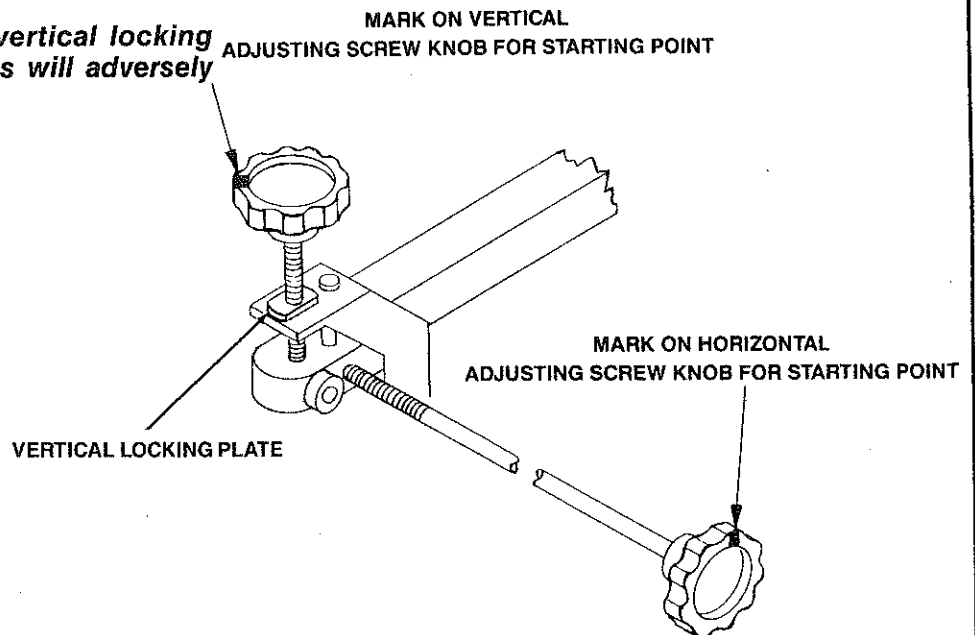

FIG. 70-A

OPERATING INSTRUCTIONS

ALIGNING REELS IN THE HORIZONTAL PARALLELISM



CAUTION: This is a critical set up and care should be taken when making these adjustments. If reel is out of position in the horizontal plane, it will be ground cone shaped. (See FIG. 11)

- A. Place set up gauge on the right hand side of reel approximately 2" from the end and lock into both the front and rear rails of the base. (See FIG. 72)
- B. Lower the indicator slide casting on the vertical support so the indicator rod can make contact with the center of the reel shaft until contact is made.
- C. Now loosen the wing screw on the indicator stop bar. Holding the indicator rod firmly against the reel shaft, move the indicator stop bar back, until no contact is made with the indicator rod plunger. Now move indicator stop bar forward until contact is made and then an additional 1/2". This will set the plunger at about its midpoint and allowing it to move in both directions. (See FIG. 73)
- D. Now set the outer dial indicator to the "0" position. Read and note the position of the smaller (.100) dial. You must know this reading when setting up the other side. More detailed explanation will follow. (See paragraph "F" for example—STEP 1.)
- E. Move the alignment gauge to the left side of the reel carefully retracting the indicator rod so as not to damage or change setting. Set indicator rod on the same position on the reel as on the other side, that is 2" from the end and centered on the shaft. (See FIG. 74) Now read the dial indicator to determine the distance the reel is out of position. (See paragraph "F" for example—STEP 2.)

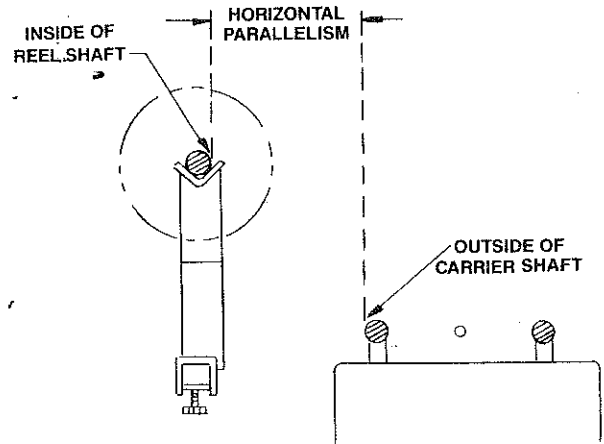

FIG. 71

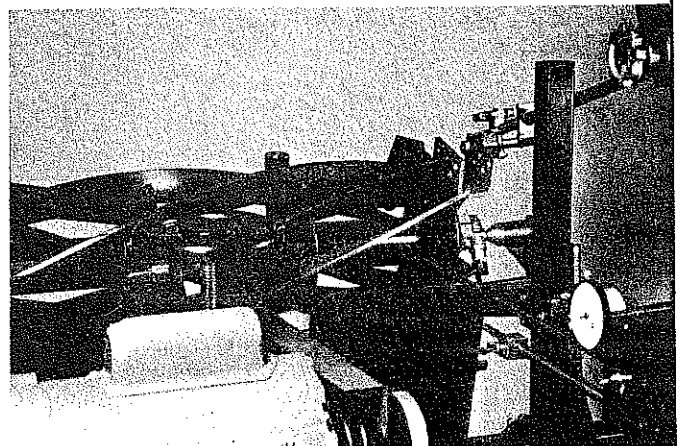

FIG. 72

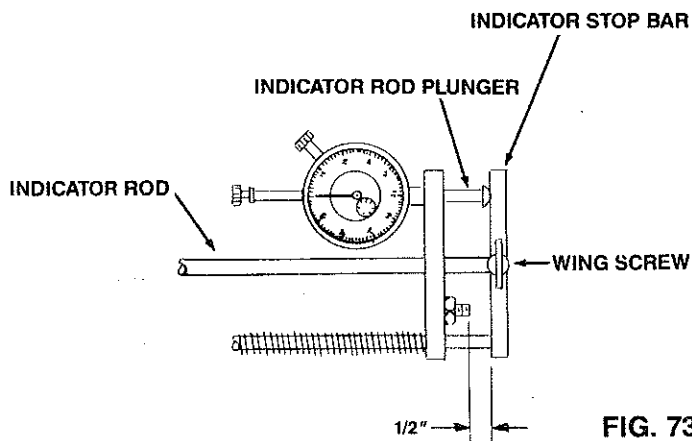

FIG. 73

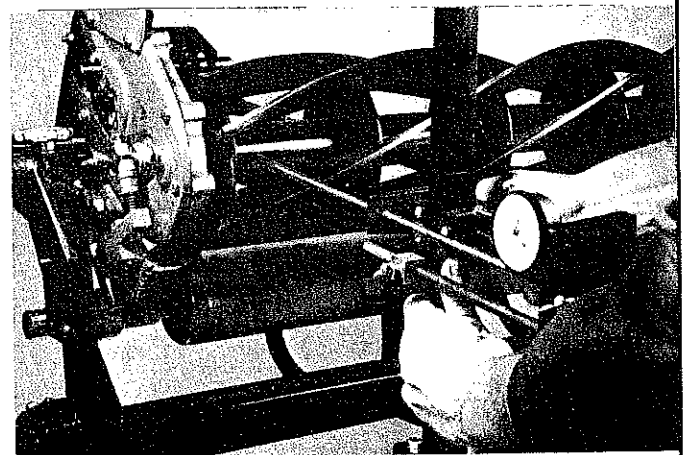

FIG. 74

OPERATING INSTRUCTIONS

ALIGNING REELS IN THE HORIZONTAL PARALLELISM . . . continued

F. The following example shows how to read the dial indicators. One revolution of large dial is equal to .100. This is indicated on the small dial by it increasing or decreasing one number (Example = 5 to 6 is .100) (See FIG. 75A & 75B)

STEP 1. Read the dial indicator on the right side of reel shown as Position A in FIG. 76. Now read dials as shown in FIG. 75-A.

	Large Dial	Small Dial
Set Large Dial	0	5

NOTE: The large dial was set at "0" in Step D.

STEP 2. Move the dial indicator to the left side as shown in Position B in FIG. 76 and read the dials as shown in FIG. 75-B.

	Large Dial	Small Dial
Note Rotation	80 (CW)	6 (CCW)

STEP 3. Read the difference between each position. Shown as C DIAL INDICATOR DIFFERENCE READING in FIG. 76.

Large Dial	.080
Small Dial	.100
So "C" Equals	.180
Reference .680 - .500 =	.180

STEP 4. To establish the overtravel distance "D" in FIG. 76, you do as follows:

First, you must compensate for the left side being out .180 by adjusting the horizontal adjustment to "0" FIG. 75 A. As you adjusted the left side to "0", the right side was moving. To compensate for this, take 1/2 of "C" plus 10% of "C".

Example: 1/2 of "C" (.180) = .090
 10% (.10) x "C" (.180) = .018
 so "D" equals .090 + .018 or .108

The reason for this is that the square mounting bar pivots on one end and is adjusted on the opposite end. Anytime the adjusting end is moved to change the position B dimension, the position A dimension is also changing at a ratio to position B. By over compensating at the adjusting end you will compensate for this movement and get the reel in line much faster. (See FIG. 76)

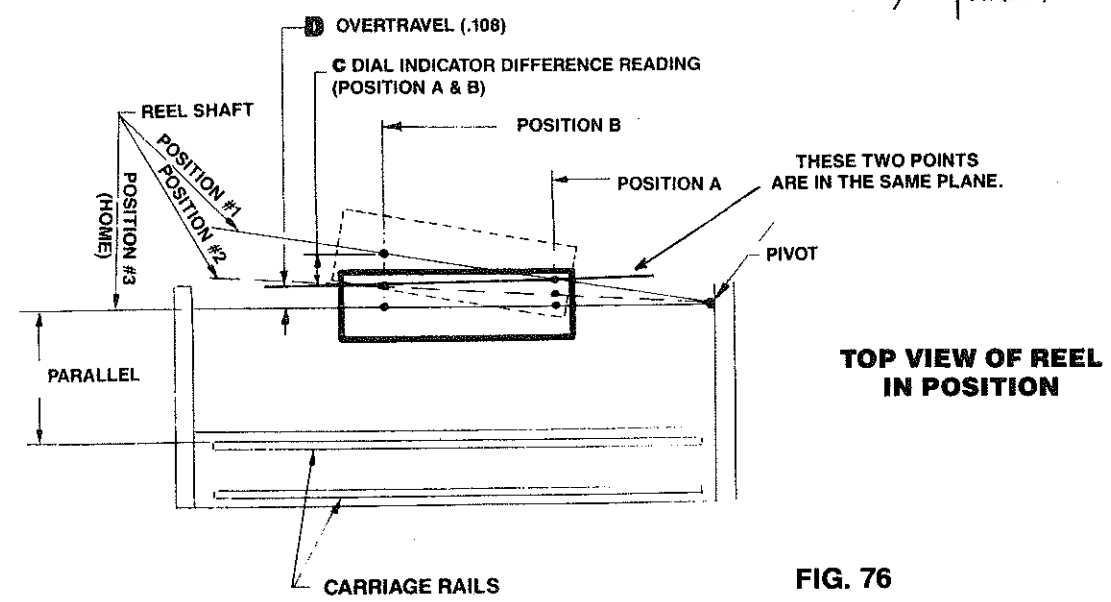
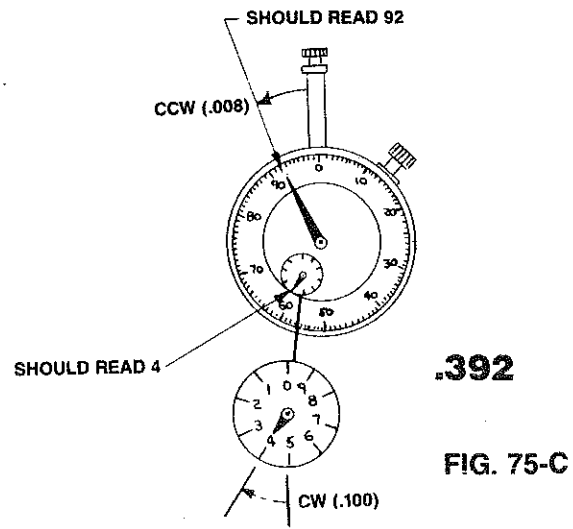
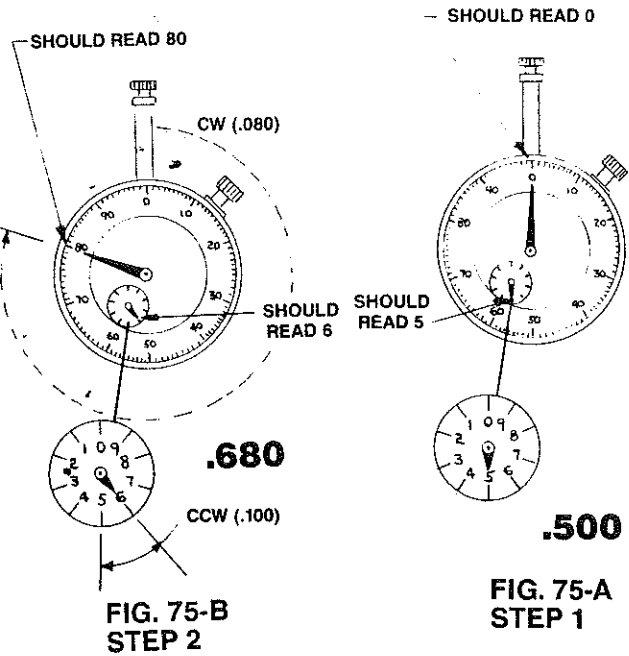

OPERATING INSTRUCTIONS

ALIGNING REELS IN THE HORIZONTAL PARALLELISM . . continued

G. To adjust reel position first determine the direction the reel has to move for alignment. The direction that the reel will have to be moved can be determined by pulling back on the dial indicator stop bar and if the dial moves back to the "0" position you will have to move the reel towards you. If that cannot be done the reel will have to be moved away from you.

There are two adjusting steps for final positioning of the reel as follows:

1. With the reel set gauge still in the left hand side of reel, turn the horizontal adjusting screw (FIG. 77-A) in the direction required to match the initial indicator reading on the right hand reel position side. (See FIG. 75A)

Example:

See paragraph F, Step 1 dial indicator reading.

Large Dial — 0 Small Dial — 5

2. Now travel farther by the amount shown in paragraph F, Step 4 to put the reel in reel position 3 (HOME). (See FIG. 76)

Example: $D = .108$

See FIG. 75-C for indicator reading at final position No. 3 (HOME) shown at FIG. 76. This indicator is to move a total of .108 thousands, .100 thousands on the small dial, then .008 thousands on the large dial.

(Reference: $.500 - .108 = .392$)

- H. Now move the set up stand back to the right side of the reel. Set indicator rod on the same spot you used the first time and re-set large dial on "0". Make sure you read the setting on the small scale and note. Then proceed with paragraph "G". This should give final adjustment. When you have done this procedure a few times you will find this procedure will become very easy.



It is essential that care is taken when setting the reel up in the horizontal positions in order to grind it into a cylinder shape. Any misalignment will cause you to grind into a cone.

(See FIG. 78)

- I. When the horizontal parallelism has been adjusted to within .003" end to end tighten the horizontal adjustment locking knob (See FIG. 77-A), and both overhead clamp adjusting knobs. (See FIG. 77-B)



Firmly tighten all locking knobs before grinding. Any looseness will adversely affect grind quality.

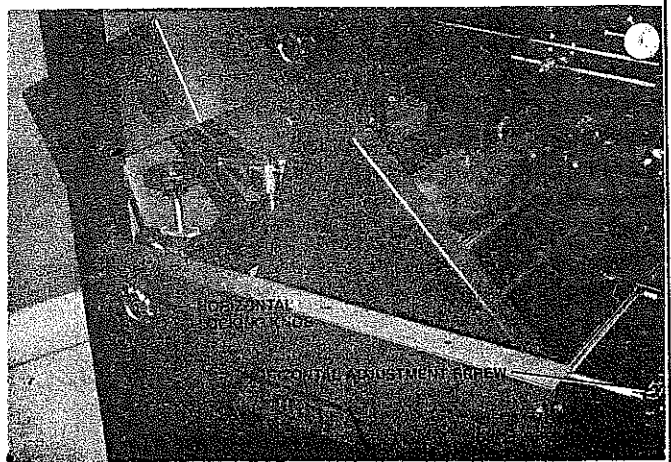

FIG. 77-A

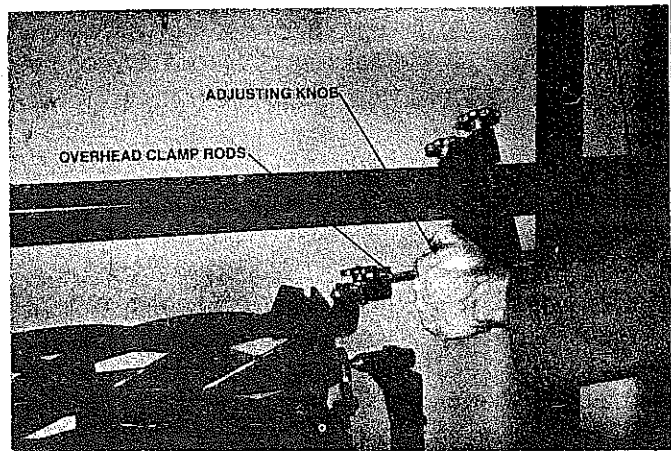

FIG. 77-B

STEPS SUMMARY—

- STEP 1—** Measure right side. Record dial indicator reading.
- STEP 2—** Measure left side. Record dial indicator reading.
- STEP 3—** Calculate difference between right and left dial indicator values.
- STEP 4—** Calculate overtravel distance. Total movement will be amount from Step 3 "C" **PLUS** the overtravel distance "D". Movement brings you to this total HOME position #3 and on recheck dial should indicate 0-0 left to right.

OPERATING INSTRUCTIONS

CHECKING REEL FOR CONE SHAPE BEFORE GRINDING, REEL ROUNDNESS, STRAIGHTNESS OF REEL OUTSIDE DIAMETER.

- A. Before storing the set-up gauge, it is very effective to use it to check the unground reel to determine the amount the reel is conical in shape or which end has the larger diameter. (See FIG. 78) Start with the set-up gauge at the right end of the reel. Loosen the wing nut on the indicator stop bar, holding the indicator rod firmly against one blade (see FIG. 81). Pull the indicator stop bar back until it clears the plunger then advance it forward until it contacts the plunger and advances it 1/2 inch further. Lock in place. This sets the plunger at its midpoint and allows adequate movement in both directions. Set outer dial at zero and note position of pointer on small dial.
- B. Now move it to the left side of reel and indicate the same blade. From the reading determine the amount the reel is cone shaped. This also determines high point for grinding. Grinding of a reel should always start at the high point.
- C. After grinding a reel, check the roundness on each end of the reel and center before removing ground reel. (See FIG. 81)
- Loosen the wing nut on the indicator stop bar, holding the indicator rod firmly against one blade. Pull the indicator stop bar back until there is a 1/32" gap between it and the set screw. This is to permit rotation of the reel blades to ride on the domed anvil only. (See FIG. 80) At each location (left, right and center) turn the reel by hand and observe the indicator variations. All readings should be within .002".
- D. Straightness of reel outside diameter—Take indicator readings at both ends of reel. Compare readings between each end of reel for straightness. All readings to be within .002".
- E. Carefully remove dial set up stand and store in safe clean location.

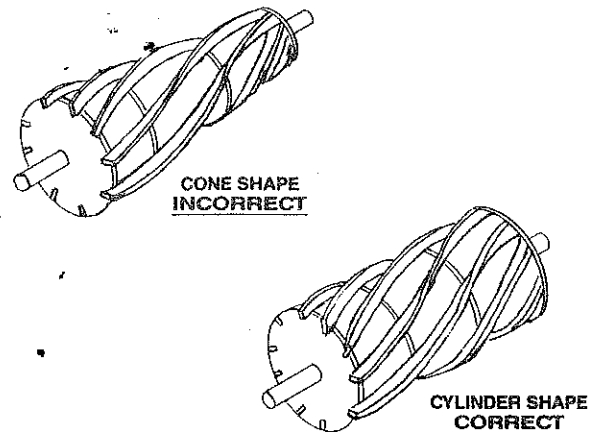

FIG. 78

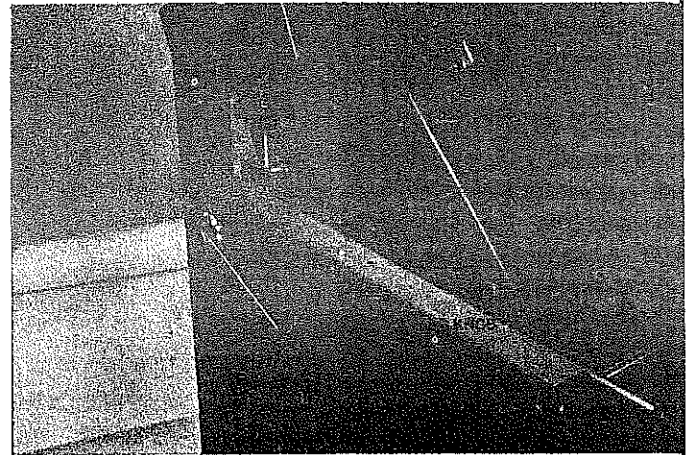

FIG. 79

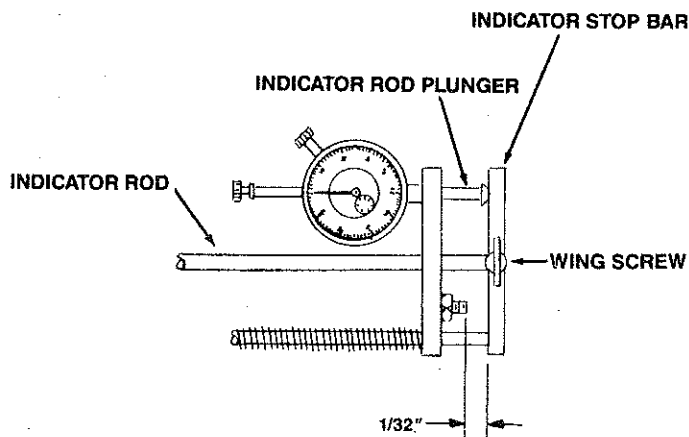

FIG. 80

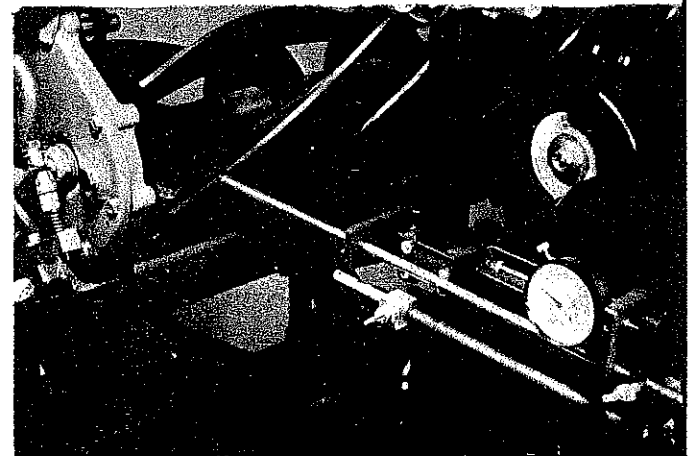

FIG. 81

SAFETY INSTRUCTIONS



Safety Awareness Symbols are inserted in this manual to alert you to possible **Safety Hazards**. Whenever you see these symbols, heed their instructions.



The **Warning Symbol** identifies special instructions or procedures which, if not correctly followed, could result in personal injury, or loss of life.

The **Caution Symbol** identifies special instructions or procedures which, if not strictly observed, could result in damage to, or destruction of equipment.

1. **KEEP GUARDS IN PLACE**
and in working order.
2. **REMOVE ADJUSTING KEYS AND WRENCHES.**
Form the habit of checking to see that keys and adjusting wrenches are removed from tool before turning it on.
3. **KEEP WORK ARE CLEAN.**
Cluttered areas and benches invite accidents.
4. **DON'T USE IN DANGEROUS ENVIRONMENT.**
Don't use power tools in damp or wet locations, or expose them to rain. Keep work area well lighted.
5. **KEEP CHILDREN AWAY.**
All visitors should be kept a safe distance from work area.
6. **MAKE WORKSHOP KID-PROOF.**
With padlocks, master switches, or by removing starter keys.
7. **DON'T FORCE TOOL.**
It will do the job better and safer at the rate for which it was designed.
8. **USE RIGHT TOOL.**
Don't force tool or attachment to do a job for which it was not designed.
9. **WEAR PROPER APPAREL.**
Wear no loose clothing, gloves, neckties, rings, bracelets, or other jewelry which may get caught in moving parts. Nonslip footwear is recommended. Wear protective hair covering to contain long hair.
10. **ALWAYS USE SAFETY GLASSES.**
Also use face or dust mask if cutting operation is dusty. Everyday eyeglasses only have impact resistant lenses, they are NOT safety glasses.
11. **SECURE WORK.**
Use clamps or a vise to hold work when practical. It's safer than using your hand and it frees both hands to operate tool.
12. **DON'T OVERREACH.**
Keep proper footing and balance at all times.
13. **MAINTAIN TOOLS WITH CARE.**
 - Keep tools sharp and clean for best and safest performance. Follow instructions for lubricating and changing accessories.
14. **DISCONNECT POWER FROM TOOLS**
Before servicing, when changing accessories, such as blades, bits, cutters, and the like.
15. **REDUCE RISK OF UNINTENTIONAL STARTING.**
Make sure switch is in off position before plugging in.
16. **USE RECOMMENDED ACCESSORIES.**
Consult the equipment manufacturer's manual for recommended accessories. The use of improper accessories may cause risk of injury to person.
17. **NEVER STAND-ON TOOL.**
Serious injury could occur if the tool is tipped or if the cutting tool is unintentionally contacted.
18. **CHECK DAMAGED PARTS.**
Before further use of the tool, a guard or other part that is damaged should be carefully checked to determine that it will operate properly and perform its intended function—check for alignment of moving parts, binding of moving parts, breakage of parts, mounting, and any other conditions that may affect its operation. A guard or other part that is damaged should be properly repaired or replaced.
19. **NEVER LEAVE TOOL RUNNING UNATTENDED.**
TURN POWER OFF.
Don't leave tool until it comes to a complete stop.
20. **KNOW YOUR POWER TOOL.**
Read the owner's manual carefully. Learn application and limitations as well as specific potential hazards peculiar to this tool.
21. **KEEP ALL SAFETY DECALS CLEAN & LEGIBLE.**
If safety decals become damaged or illegible for any reason, replace immediately. Refer to the Exploded View drawings at the back of the manual for the proper location and order numbers of safety decals.

OPERATING INSTRUCTIONS

GRINDING REEL INTO A TRUE CYLINDER BY SPIN GRINDING

A. Before you proceed any further, check all knobs to insure they are tight.



Firmly tighten all locking knobs before grinding. Any looseness will adversely affect grind quality.

- B. There are three (3) hand knobs for locking the grinding wheel vertically. Two on the base for the adjusting arm locks and one for grinding wheel vertical height adjustment locking screw.
- C. Position the height of the grinding wheel center so that it is 3 to 4" below the reel center. This will make sure the reel guide finger will clear the reel (See FIG. 83)
- D. In-feed the grinding wheel until it just makes contact with the reel and rotate the reel by hand to make sure the blades clear the stop finger. Now tighten both locking knobs on the locking arms and the locking knob for the height adjustment screw.



It is critical that the reel be hand rotated to verify stop finger clearance. Failure to do so could cause significant damage to the reel and grinder.

E. Move the grinding wheel back from the reel and frame so it will clear at all points. Set traverse stop so they line up approximately with the end of the frame and tighten them securely. Adjust the traverse speed knob to zero and turn traverse switch to on. Increase the traverse speed now so the carriage will traverse slowly across the reel. (See FIG. 84-A & B)

When the carriage has come to a momentary stop against carriage stop, turn traverse switch off. In this position, check to see that grinding wheel has cleared the end of the reel. If not, readjust stop so that this happens.



CAUTION: If the reel frame extends past the reel itself, make sure the stop is set so that the grinding wheel will not run into frame when grinding. It is possible that in some cases this will mean the grinding wheel will not clear the end of the reel when grinding.

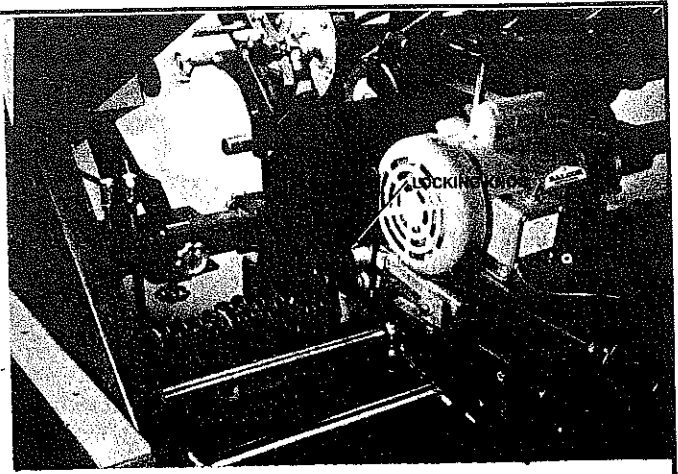

FIG. 82

THE REEL AND GRINDING WHEEL ARE TO ROTATE IN THE SAME DIRECTION.

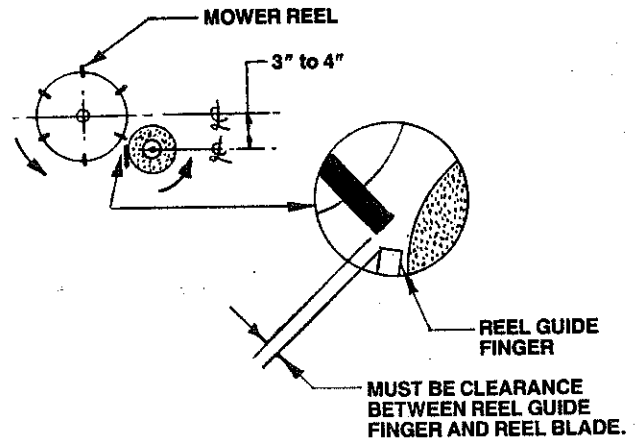

FIG. 83

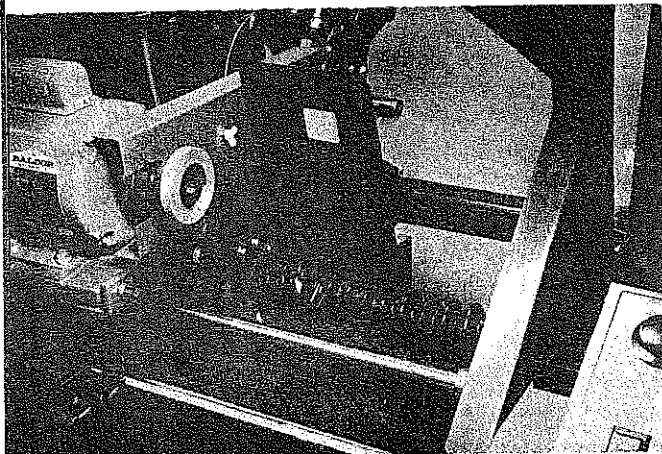

FIG. 84-A

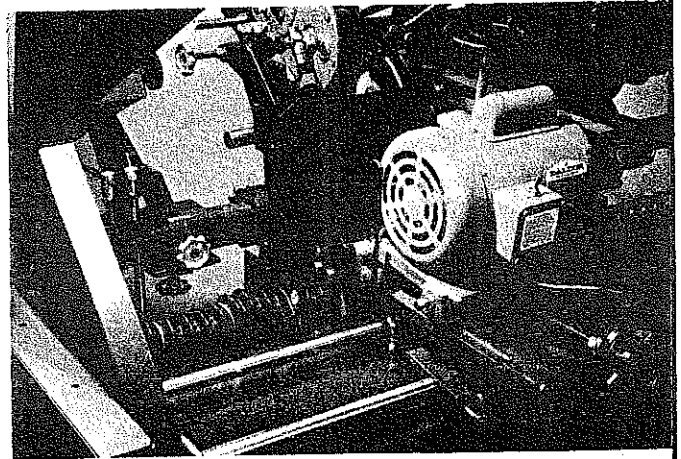

FIG. 84-B

OPERATING INSTRUCTIONS

GRINDING REEL INTO A TRUE CYLINDER BY SPIN GRINDING—continued

- F. Repeat this procedure for the other side of the reel and then set the traverse speed dial to "10" and let carriage traverse back and forth to make sure that stops are set properly.
- G. Move grinding carriage to the high side end of the reel and stop carriage.
- H. Turn on spin drive motor and check to see if reel is spinning freely and that coupling components are properly aligned.



WARNING! Care should be taken of your hands and clothing around the spinning reel and rotating coupler shafts. At no time should reel be started by revolving it by hand.

- I. Turn on grinding wheel motor on main control panel. There is a secondary switch on the motor itself that must be in the "On" position. Now slowly in-feed the grinding wheel until it just makes contact with the reel. (See FIG. 85)
- J. Set traverse speed knob to approximately "12," then turn on the traverse switch and begin grinding. If reel is in bad condition traverse slower as more material can be removed. Conversely if reel is in good condition speed can be increased.



CAUTION: Maximum stock removable per pass is .008. This is approximately 1/2 turn of in-feed handle.

- K. If the grinding wheel is only making contact in one position of the reel, adjust the traverse stop so the carriage traverses slightly further than the contacted area. As you in-feed and wheel makes full contact in this area move traverse stop away 6" to 8". This will speed up the grinding process of getting a cone shaped reel into a perfect cylinder. (See FIG. 86)
- L. Spin grinding is completed when full contact is made across the entire length of the reel and the entire width of all blades. It is required to have a sparkout to complete grinding the outside diameter to a true diameter. For sparking out, the process is to in-feed the grinding head for only approximately .002 stock removal (approximately 1/8 turn of handwheel) in final two passes and let the grinding wheel sparkout. For sparking out in grinding process always traverse grinding head 20 passes with no grinding head infeed. Set traverse at slow speed on dial setting approximately 4 to 8 feet per minute range for final grinding sparkout. After sparkout, shut the grinder completely off.

NOTE: This process refers to sparkout, but what we are looking for is a near sparkout, approximately a 99% reduction in grinding spark from normal grind. Do not run sparkout until you have no sparks because this could be an extremely extended period.

NOTE: Greatest accuracy and best finish is obtained when reel is sparked out.

Use your set up gauge, prior to relief grinding to check the reels for roundness. This is very important when first learning operation of your machine.

Index reel blade until you read the high point on the indicator. Now loosen the wing screw and set the indicator stop block to a 1/32" gap as shown in FIG. 80 & 81, page 31.

Mark this blade as #1 and set the large dial of indicator setting to "0," then check each blade for maximum and minimum reading. Check each end of reel and at the center. After becoming familiar with the process you will not have to check each reel.



CAUTION: It is very important in spin grinding that you thoroughly sparkout at the end of the grind cycle. The difference of achieving .005 or .003 total reading is accomplished from sparking out. Sparking out is accomplished when not in-feeding the grinding wheel.

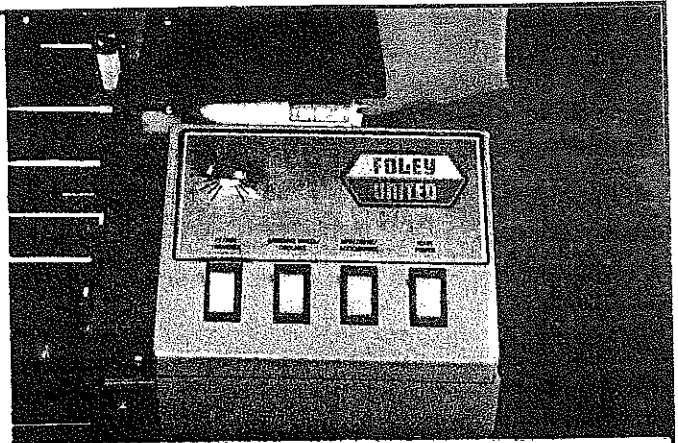

FIG. 85

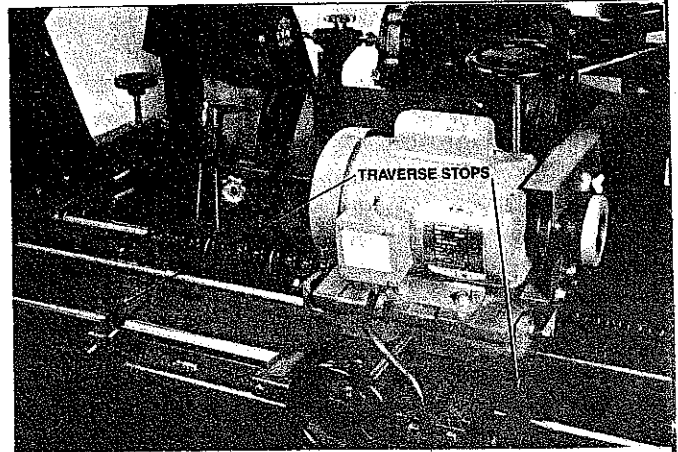

FIG. 86

OPERATING INSTRUCTIONS

RELIEF GRINDING TO COMPLETE THE REEL GRINDING PROCESS

- A. Disconnect the spin drive coupling components from the reel and place in tool tray.
- B. Check to see if your mowing unit is a left hand or right hand spiral.

NOTE: As you look into the guide finger in FIG. 89-A it shows the right hand reel spiral. The high point of finger guide is on the right hand side of the grinding wheel. See FIG. 89-B for left hand spiral.

Most mowing units are right hand spiral so traverse your carriage to the right hand side of reel for starting position. Traverse carriage until there is at least $.125$ ($1/8"$) clearance to the guide finger for indexing. (See FIG. 87 and FIG. 90) Set the right hand traverse stop for this carriage reversing position.

Traverse to the other end of the reel blade until the guide finger is beyond the point of grind by approximately $.125$ ($1/8"$) to $.75$ ($3/4"$). Set the left hand traverse stop for this carriage reversing position.

- C. There are three (3) hand knobs to loosen. Two on the base for the adjusting arm locks and one for grinding wheel vertical height adjustment locking screw. Raise the grinding wheel up (approximately 7 turns) so the reel blade can rest on the reel guide finger. It will be necessary to infeed the grinding wheel to accomplish this. (See FIG. 88)
- D. Now you can adjust the back relief angle you wish to put on the reel blade. 15° is the recommended angle. By looking down the reel from the right side you can see the reel and its relative position to the grinding wheel. By raising the grinding wheel you will decrease the back angle and conversely by lowering the grinding wheel you will increase the back relief angle. Traverse the grinding wheel assembly to the right side of the reel. Retighten all three hand knobs.

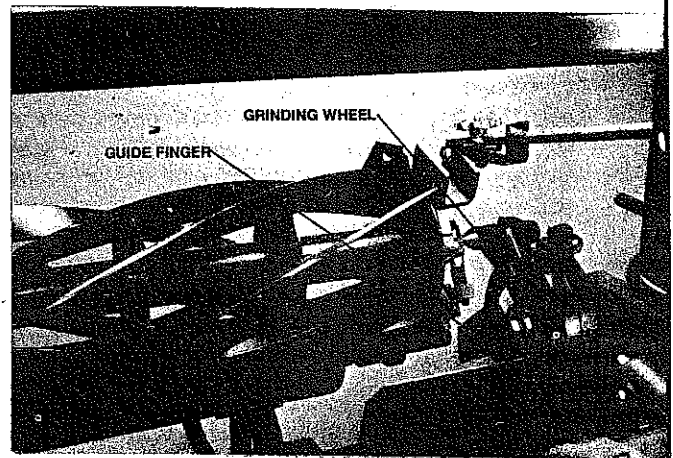

FIG. 87

SIDE VIEW OF GRINDING WHEEL

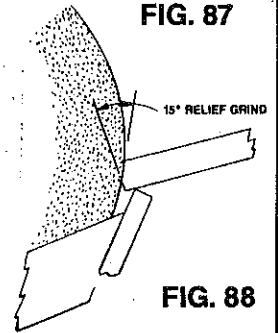

FIG. 88

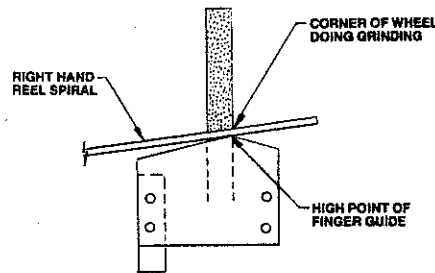

FIG. 89-A

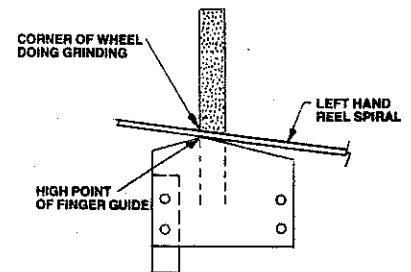

FIG. 89-B



The high point of the guide finger is always at the corner of the grinding wheel that is making contact with the reel. (See FIG. 89-A and 89-B)

Rotate finger guide end for end when reel spiral is in the opposite direction as shown in FIG. 89-B.

- E. It is recommended that you practice indexing the blades for relief grinding prior to actually grinding them. Do this by backing the grinding wheel away from blade so that virtually no contact is made with the blade that is resting fully on the guide finger. Now with the grinding wheel not turning, turn on traverse motor and set at 6 and let grinding assembly traverse down. On the return stroke, always come back on the same blade. After traversing down and returning on a blade, relief grinding requires the operator to manually index to the next blade. This is a critical operation and should be well practiced prior to grinding. See Warning on page 36. When on the practice run you have to hold the reel down to the finger on the return stroke.

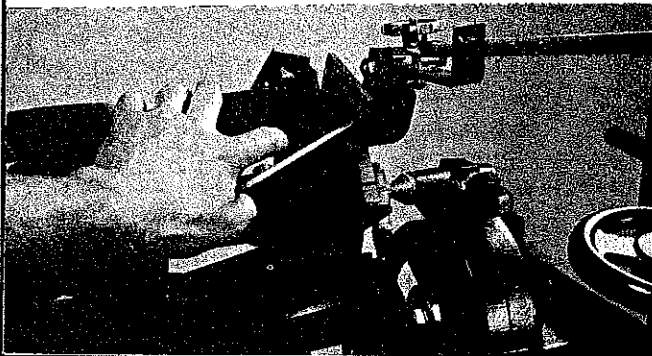
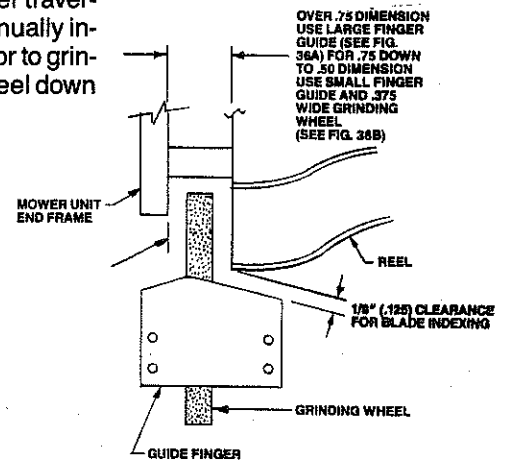

FIG. 90



OPERATING INSTRUCTIONS



It is necessary to manually position the reel blade on the guide finger. If you over-index and miss the finger the grinding wheel will be jammed between two blades. If you under-index the grinding wheel will be jammed against the blade you are trying to grind. Extreme care must be taken in learning this procedure as serious personal injury could occur if the operator contacts the grinding wheel or is caught in a grinding wheel to reel jam. Practice until you are satisfied with your capability.

When you are comfortable with this procedure continue with the next step in actually grinding.

NOTE: At each end of the stroke when reversing, there is to be a 1-second pause. This can be increased. See control board settings in the adjustment section of the manual. The 1-second hesitation at the end of the stroke permits time to manually index the reel.

- F. Infeed grinding wheel so that approximately 50% of the reel blade will be ground. It is recommended that 60% of the reel blade be relief ground when finished. (See FIG. 91)
- G. With the reel blade resting on the finger guide but not making reel contact with the grinding wheel set the traverse speed dial to "0," turn on the grinding wheel motor and traversing motor.
- H. Hold the reel to the guide finger with your left hand and turn the traverse speed to 6". As soon as the grinding wheel contacts the reel, remove your hand. The guide finger will keep the reel in place as the grinding assembly traverses across the reel. When it reaches the left side of the reel the reel blade leaves the guide finger and then traverse switches reverses carriage to the opposite direction. The guide finger will automatically pick up the same reel blade and will be held down to the guide finger with the rotation of the grinding wheel driving force downward.
- I. Now continue grinding each blade by indexing them as practiced in procedure "E." When each blade has been ground inspect to see if proper relief has been attained. If not, reset wheel as in procedure "D" and regrind as before. Normally one grinding pass will be sufficient.
- J. If the reel blades are too close together or the clearance between mower unit is too narrow (see FIG. 90) and will not permit you to use the large reel finger guide it will be necessary to use the alternate stamped finger guide. In order to use this guide you will be required to dress the grinding wheel as follows: Place the guide finger on the grinding motor assembly and position about 1/16" away from the grinding wheel. Now from the back of the machine mark the distance from the high side of the finger to the left side of the wheel with a light colored grease pencil. Now, with grinding wheel assembly in a position where you can reach it with the dressing stick, turn on the grinding wheel and dress the portion of the wheel you have marked at approximately 10°. (See FIG. 92)
- K. The grinding procedures for using this finger will be the same as when using the larger guide finger, but because of its relative small size it is recommended that you index from blade to blade in the following manner: When grinding wheel assembly makes contact with the right traversing stop and pauses before reversing direction. Turn the traversing speed dial to "0" this will stop the grinding head carriage. Now index the next blade and slowly turn dial to move the grinding wheel into the reel while you position the blade onto the guide finger. Once finger is in place and grinding has started turn the speed dial to "6" and continue to grind as before. This procedure will be necessary for every blade.

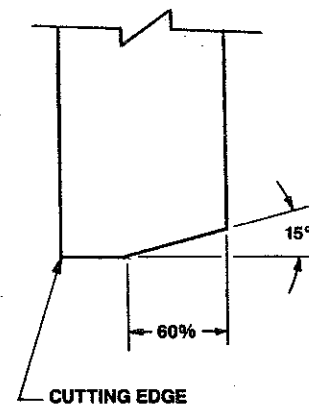

FIG. 91

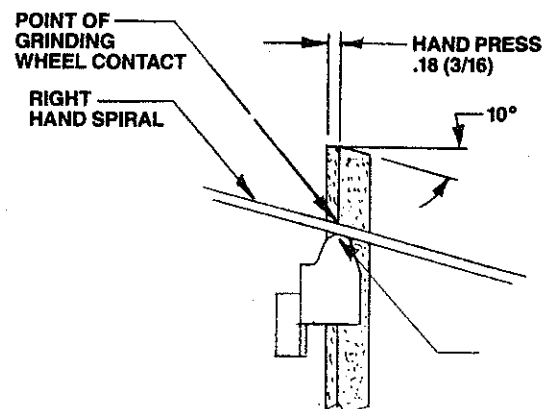
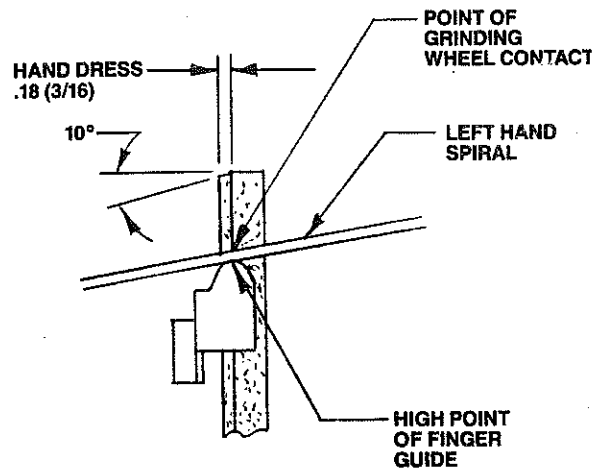

FIG. 92