

388 MANUAL REEL MOWER GRINDER

ASSEMBLY and SERVICE MANUAL



WARNING

You must thoroughly read and understand this manual before maintaining the equipment, paying particular attention to the Warning & Safety instructions.

SAFETY INSTRUCTIONS

Safety Awareness Symbols are inserted into this manual to alert you to possible **Safety Hazards**. Whenever you see these symbols, follow their instructions.



The **Warning Symbol** identifies special instructions or procedures which, if not correctly followed, could result in personal injury.



The **Caution Symbol** identifies special instructions or procedures which, if not strictly observed, could result in damage to or destruction of equipment.

1. **KEEP GUARDS IN PLACE** and in working order.
2. **REMOVE WRENCHES AND OTHER TOOLS.**
3. **KEEP WORK AREA CLEAN.**
4. **DON'T USE IN DANGEROUS ENVIRONMENT.** Don't use Grinder in damp or wet locations, or expose it to rain. Keep work area well lighted.
5. **KEEP ALL VISITORS AWAY.** All visitors should be kept a safe distance from work area.
6. **MAKE WORK AREA CHILD-PROOF** with padlocks or master switches.
7. **DON'T FORCE THE GRINDER.** It will do the job better and safer if used as specified in this manual.
8. **USE THE RIGHT TOOL.** Don't force the Grinder or an attachment to do a job for which it was not designed.
9. **WEAR PROPER APPAREL.** Do not wear loose clothing, gloves, neckties, or jewelry which may get caught in moving parts. Nonslip footwear is recommended. Wear protective hair covering to contain long hair.
10. **ALWAYS USE SAFETY GLASSES.**
11. **SECURE YOUR WORK.** Make certain that the cutting unit is securely fastened with the clamps provided before operating.
12. **DON'T OVERREACH.** Keep proper footing and balance at all times.
13. **MAINTAIN GRINDER WITH CARE.** Follow instructions in Service Manual for lubrication and preventive maintenance.
14. **DISCONNECT POWER BEFORE SERVICING,** or when changing the grinding wheel.
15. **REDUCE THE RISK OF UNINTENTIONAL STARTING.** Make sure the switch is OFF before plugging in the Grinder.
16. **USE RECOMMENDED ACCESSORIES.** Consult the manual for recommended accessories. Using improper accessories may cause risk of personal injury.
17. **CHECK DAMAGED PARTS.** A guard or other part that is damaged or will not perform its intended function should be properly repaired or replaced.
18. **NEVER LEAVE GRINDER RUNNING UNATTENDED. TURN POWER OFF.** Do not leave grinder until it comes to a complete stop.
19. **KNOW YOUR EQUIPMENT.** Read this manual carefully. Learn its application and limitations as well as specific potential hazards.
20. **KEEP ALL SAFETY DECALS CLEAN AND LEGIBLE.** If safety decals become damaged or illegible for any reason, replace immediately. Refer to replacement parts illustrations in Service Manual for the proper location and part numbers of safety decals.
21. **DO NOT OPERATE THE GRINDER WHEN UNDER THE INFLUENCE OF DRUGS, ALCOHOL, OR MEDICATION.**

UNCRATING AND ASSEMBLY INSTRUCTIONS

This machine is intended for manual reel mower reel blade and bed knife grinding ONLY. Any use other than this may cause personal injury and void the warranty.



To assure the quality and safety of your machine and to maintain the warranty, you MUST use original equipment manufactures replacement parts and have any repair work done by a qualified professional.

ALL operators of this equipment must be thoroughly trained BEFORE operating the equipment.

Do not use compressed air to clean grinding dust from the machine. This dust can cause personal injury as well as damage to the grinder.



Use care when unpacking. Double-check the packing cartons for any miscellaneous items before discarding.

Inspect all items for shipping damage as they are removed from the shipping containers. If you find any damage, notify the carrier's claims agent and do not proceed further until the damage has been inspected by the agent. Refer also to the "Shipping and Receiving Instructions" packed with this unit.

UNCRATING

1. Remove the shipping crate sides, ends and top.
2. Cut the band and remove the grinding head assembly and set aside.
3. Remove the elevator components and set aside.
4. Remove the overhead bar taped to the frame rail and set aside.
5. Remove the corrugated box from the crate. Remove all items from the box and sort out on a table.

Check all items against the exploded view drawings in the rear of this manual to ensure that all items were shipped properly.

Remove Main Base Assembly from wood pallet.



The Main Base Assembly weighs 215 lbs (100 kg). To lift, use power equipment or get adequate help.

To remove the Main Base Assembly from the wood pallet:

1. Unbolt the four lag bolts that hold each end of the Main Base Assembly to the pallet.

NOTE: A number symbol and number in parenthesis (#__) refers to the item number in the parts list section of this manual.

INSTALLATION

ASSEMBLE LEG LEVELERS TO BASE ASSEMBLY

Place leg leveler foot (#43) and 1/2" nut (#60) into tapped holes in cast leg base (#5), see FIG. 1, and adjust to a uniform 1" [25 mm] leaving the nut loose.

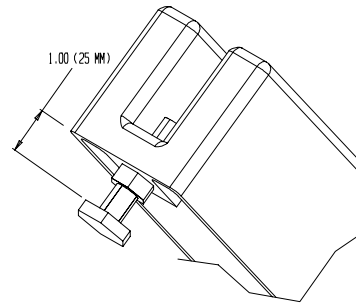


FIG. 1

LOCATE AND LEVEL THE GRINDER

Set the Grinder on a level concrete floor, on a single uncracked slab of concrete.



Placing the grinder on a floor that is badly out of level or broken will affect grinding quality.

If the unit must be located near a wall, allow adequate space for operating and servicing. The clearance required around the grinder is a 36" [90 cm] minimum on the two sides and the front and 48" [120 cm] minimum to the rear as shown in FIG. 2.

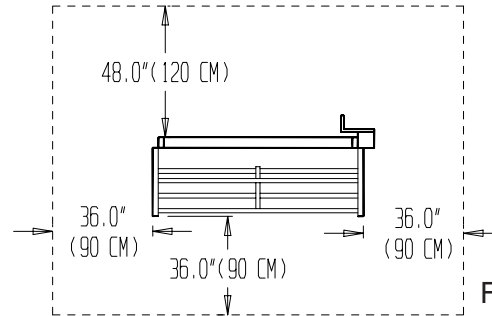


FIG. 2

Place a level on the front carriage rail near the center of the machine and check the level from left to right. See FIG. 3. Adjust the leveling feet until the machine is level.



FIG. 3

Place the level across the front and rear carriage rails near the left end of the machine. See FIG. 4. Adjust the two leveling feet on the left end until the rails are level.

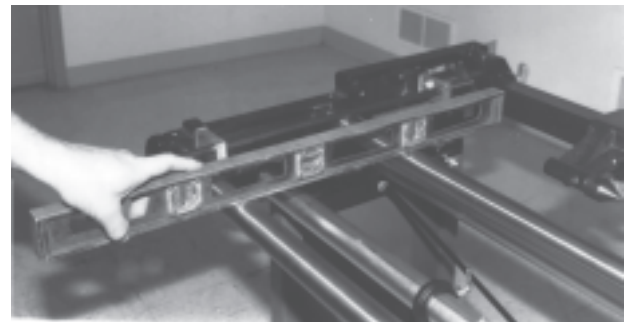


FIG. 4

Place the level across the front and rear carriage rails near the right end of the machine. Level the right end in the same way as the left end. See FIG. 5. For grinding accuracy, the two ends must be level within +/- .015 in. (.4 mm) so the frame is not twisted.

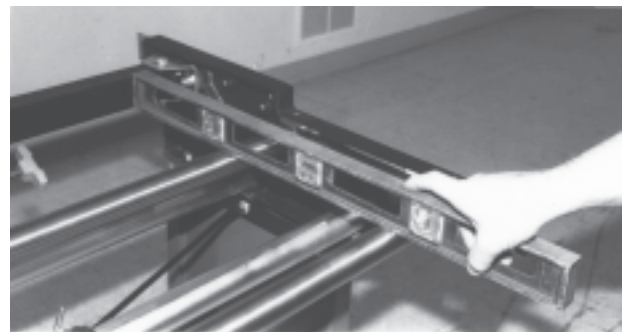


FIG. 5

Recheck the level in both directions. When satisfactory, tighten the hex jam nuts (#60) on the leveling feet securely against the bottom of the base. See FIG. 1. Do not turn the leveling feet when tightening.

Again recheck the level after the nuts are firmly tightened.



For grinding accuracy, the machine does not have to be perfectly level. However, IT IS CRITICAL that front-to-back leveling be the same at both ends of the machine.

INSTALLATION (Continued)

INSTALL REEL ELEVATOR

Bolt the left and right end frames to the top and bottom mounting brackets already attached to the end panels using four 3/8-16 x 3/4" hex head cap screws (#14), two flatwashers over the top bracket slots (#19), four lock washers (#21) and four nuts (#16). The mounting bracket might have to be loosened and adjusted to line up with the end frames. Bolt the end frame with the decal on the winch end (right end of unit as viewed from the operator's position) See FIG. 6. Bolt gussets loosely to the overhead channel, which is installed with the pulleys on top, using eight 3/8-16 x 3/4" long hex head screws (#14), eight lock washers (#21) and eight nuts (#16). Lift overhead channel into position (Note the position of the bracket in FIG. 6) and bolt to end frames using eight 3/8-16 x 3/4" long hex head screws (#14), lock washers (#21) and nuts (#16). Align and securely tighten all nuts.

Attach the winch to the right side of unit as viewed from the operator's position with the crank handle facing to the rear. Install two 3/8-16 x 3/4" long hex head cap screws (#14) and one flatwasher (#19), two lock washers (#21) and two nuts (#16). The flatwasher goes over the winch housing slot. Assemble the winch according to the instructions provided in the manual packet.

Thread the cable through the top middle hole in the channel and over both pulleys. Attach the cable to the winch following the procedure described in the winch instructions.

The cable is reeled up by rotating handle in a clockwise direction, as it is reeled up it makes a clicking sound. The spring loaded handle actuates a brake when handle is released.

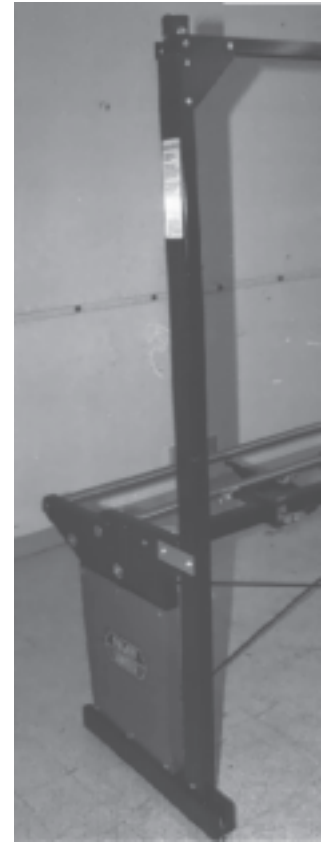


FIG. 6



Read separate directions on winch operation and maintenance that is included in the manual packet.

Place spreader bar with chains and hooks onto cable hook (which has safety latch feature built in). See FIG. 7.



Do not overload the winch capacity. Winch capacity is a maximum of 400 lbs. (180 kg)



FIG. 7

INSTALLATION (Continued)

ASSEMBLE OVERHEAD SUPPORT ARM & BAR

Assemble overhead support arm (#25) and (#26) using four 3/8 x 2-1/4" cap screws (#51), four 3/8" nuts (#59), and four lock washers (#13). Sandwich the warning panel assembly (#70) between left hand end frame (#2) and the left side support arm (#25).



FIG. 8



Warning panel assembly must be installed to protect the operator and visitors.

Install two overhead clamp castings (#8) onto the overhead bar (#37) as shown in FIG. 8. Assemble overhead bar (#37) with two 3/8" x 3/4" cap screws (#48) & two lock washers (#13) being sure to place overhead clamp castings (#8) onto overhead bar as shown before assembling. See FIG. 8.



FIG. 9

Assemble the overhead clamp assemblies. (#45,46,47,62) onto the overhead clamp castings (#8). Assemble bumper (#65) onto mower clamp weldment (#46). See FIG. 9.

MOUNT GRINDING HEAD ASSEMBLY



The Grinding Head Assembly weighs approximately 85 lbs (40 kg). To lift, use power equipment or get adequate help.

Place grinding head assembly onto machine rails. Position the carriage travel stops (#35) and clamp into place.



FIG. 10

Remove grinding wheel guard (#5), install the 6" diameter x 3/8" wide grinding wheel (#30) and snugly hand tighten. Adjust the guide finger (#13) and tighten. Then reinstall the grinding wheel guard (#5).

INSTALL DUST DEFLECTOR SHIELD

Attach the dust deflector shield with two 3/8-16 x 3/4" cap screws (#40) and two lock washers (#42). Install Dust Bag (#35) and Hose Clamp (#57). See FIG. 10.

TOOLING BAR COMPONENTS

The reel support centers are mounted horizontally on the tooling bar. Reposition them vertically on the tooling bar at this time. See FIGS. 10 and 12.

Assemble the vertical adjusting screw (#33) and lock (#15). Center the horizontal adjusting screw (#34). See FIG. 13.



FIG. 12



FIG. 13

INSTALLATION (Continued)

MOTOR WIRING & GROUNDING INSTRUCTIONS

Your Model 388 Grinder has been completely prewired at the factory, and no additional wiring is necessary. The Model 388 is set up for a 115 VAC, 50/60 HZ 1 Phase - current. The grinder operates on a 15 AMP circuit. The wall outlet should be grounded and look like the outlet shown in FIG. 14. See FIG. 15 for 115 volt motor wiring, as built.

To convert this grinder to operate on 220 V 50/60 HZ 1 phase current, cut the plug off from the cord and replace it with the appropriate plug for your locality. For plug and circuit breaker sizing, see motor nameplate ratings. Use only a qualified electrician.

To convert the grinder from 115 Volt to 220 Volt, disconnect the four wires coming from the motor internally and reconnect them as shown in FIG. 16. One additional wire nut will be required to complete. NOTE: This motor will operate correctly on 60 HZ or 50 HZ power.

GROUNDING INSTRUCTIONS

In the event of a malfunction or breakdown, grounding provides a path of least resistance for electrical current to reduce the risk of electrical shock. This tool is equipped with an electrical cord having an equipment grounding conductor and a grounding plug. The plug must be plugged into the matching outlet that is properly installed and grounded in accordance with all local codes and ordinances.

Before plugging in your machine, make sure it will be connected to a supply circuit protected by a properly sized circuit breaker or fuse.

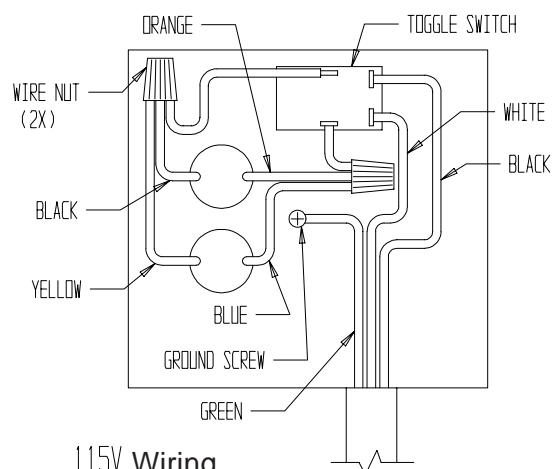
Do not modify the plug provided if it will not fit the outlet, have the proper outlet and circuit installed by a qualified electrician.



Always properly electrical ground your machine. An improper connection can cause an electrical shock. If unsure of the proper electrical grounding procedure, contact a qualified electrician.

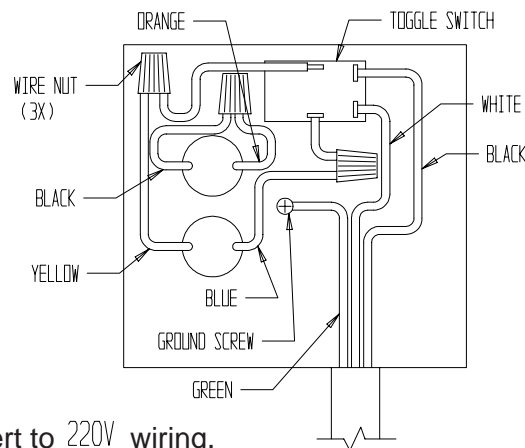


FIG. 14



115V Wiring,
as built.

FIG. 15



To convert to 220V wiring.

FIG. 16

MAINTENANCE

PERIODIC MAINTENANCE

1. Wipe and re-oil with a spray lubricant (do not use a teflon based lubricant) lead screws once a month or every 40 hours of operation.
2. Wipe and re-oil with never-seez horizontal and vertical cross slide shafts on mower support bar once a month or every 40 hours of operation.
3. Lubricate the traverse rails with a spray lubricant (do not use a teflon based lubricant) and wipe off the excess once a month or every 40 hours.
4. Check Gib plate adjustment in the grinder carriage base monthly or every 40 hours. See Page 9.
5. Check ALL Fasteners once every 3 months or 100 hours..
6. Clean dust bag when 1/2 full - approximately every 3 months or 100 hours.
7. Check the belt every 3 months or 100 hours. Check the tension and look for cracks. See Page 9.
8. Wipe and grease carriage dovetail with lithium grease every six months or every 200 hours of operation.
9. Rail Alignment - Check every 6 months or every 200 hours. See Page 9.
10. Rotate traverse shafts once a year or every 300 hours of operation. See Page 9.

MAINTENANCE ADJUSTMENTS

GIB ADJUSTMENT

The four gib set screws should be adjusted by loosening the four lock nuts and then turning in the set screws while turning the horizontal infeed handwheel. Adjust the gib for a snug movement of the slide and gib. To adjust all four set screws, it will be necessary to move the slide from front to back. **NOTE:** The slide must be fully in front of the gib screw when making adjustments. **DO NOT** adjust the gib screw without the slide positioned adjacent.

BELT TENSIONING AND REPLACEMENT

To adjust belt tension loosen the two set screws on the Head Support and push the grinding head forward to tension the belt, making sure to hold the head square and retighten the set screws. Head squareness is shown on page 7 of the Operator's Manual. After correctly tensioning the belt, check your tension with a

5 lbs [2 kg] load applied approximately in the center of the belt, you should observe 1/8" [3 mm] of deflection. See FIG. 17. To change the belt, remove the two belt guards, and loosen the set screws on the Head Support. Push the grinding head in against the internal spring and remove the belt. Install the new belt and reverse the sequence making certain to reinstall the guards.

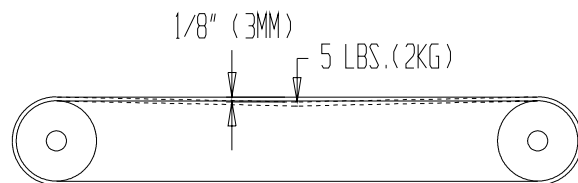


FIG. 17



DO NOT OVERTIGHTEN OR PRY ON THE GRINDING HEAD TO TIGHTEN. DAMAGE COULD OCCUR TO THE MOTOR OR GRINDING HEAD BEARING.

RAIL ALIGNMENT AND ROTATION

The front (away from the operator) carriage rail is adjustable in horizontal and vertical planes. The rear rail (nearest the operator) is adjustable only in the vertical plane. Using a **PRECISION** straight edge adjust the rails using the set screws (#54) and locknuts (#57) as shown on pages 16 and 17.

After extended use, the carriage bearings will start to wear tracks into the carriage rails. To minimize this, it is recommended that once a year or every 300 hours of operation the carriage rails should be turned. Loosen the set screws holding the carriage rails and turn the rails so the bearings run on a new track. Retighten the set screws. After rail turning, recheck rail straightness.

TROUBLESHOOTING

PROBLEM	POSSIBLE CAUSE	REMEDY	REASON
No electrical power to grinding motor.	Main power source is off.	Turn on main circuit breaker. Plug power in. Verify motor switch is on.	
Reel ground in a concave, convex, or irregular shape.	Not traversed manually with uniform travel speed.	Travel at a very steady speed on the reel blade.	Irregular speed on the blade will cause irregular grind pattern.
This is determined by irregularities in the relief grind, i.e.: larger on ends than center, vice versa, irregular relief, not uniform	Not a uniform travel speed coming off the end of reel blade.	Travel at a very steady speed across the full blade. Do not slow down near the end of the blade.	
	Overhead clamps and fixture clamps not holding mower unit tight.	Tighten down all locking hand knobs. Four hand knobs for the square tube side and bottom clamps; two knobs for the mower holding clamps; and two knobs for the mower clamp swivel. Check alignment of overhead clamp so there is no binding before locking down of hand knobs. Use allen wrench for increased tightness of appropriate knobs.	To eliminate reel movement during grinding.
	Square tube tooling bar for fixture holding is not rigid.	The pivot end is bolted on rubber mounts. On adjustable end, tighten slide end locking handles one for vertical and one for horizontal locking.	To eliminate reel movement during grinding.

TROUBLESHOOTING CONT.

PROBLEM	POSSIBLE CAUSE	REMEDY	REASON
<p>Reel ground in a concave, convex, or irregular shape, cont.</p>	<p>Grinding wheel head moving.</p>	<p>Tighten up two set screws that hold the Grinding Head into the Head Support.</p>	<p>To prevent grinding head from moving during grinding.</p>
		<p>There is a lock handle to tighten. It is the lock handle with a nylon plug at the tip to set the tension against the threads for the grinding wheel vertical height adjustment screw.</p>	
		<p>The two adjustable cone point set screws on the pivot of the motor plate need adjustment so the motor plate has no side movement.</p>	
	<p>Gibs loose on carriage.</p>	<p>Tighten gib screws to prevent movement.</p>	<p>To prevent grinding head from moving.</p>
		<p>Adjust the motor slide base forward and adjust the gib screws. Then adjust the motor slide base all the way back and adjust the final gib screws.</p>	
	<p>Carriage ball bearings worn outside diameter or internal wear.</p>	<p>Replace bearings.</p>	<p>To prevent grinding head from moving during grinding.</p>
	<p>Grinding Head Bearing has developed free play.</p>	<p>Try to move the grinding wheel from side to side with the power disconnected. If there is more than .005" [.13 mm] side movement, replace the grinding head assembly.</p>	<p>To prevent the grinding wheel from moving during grinding.</p>

TROUBLESHOOTING CONT.

PROBLEM	POSSIBLE CAUSE	REMEDY	REASON
Reel ground in a concave, convex, or irregular shape, cont.	Tooling bar support brackets are loose.	All reels are mounted with two V-support brackets or two center support brackets. Be sure they are tight to the square tooling support tube in horizontal and vertical plane. Tighten the horizontal locking screws. First, firmly pulling the center bracket over to the side of the tooling support tube. Then tighten the vertical locking handle to pull down the supports to the tooling support tube. When using center supports, check to see if the fixed center is screwed in tight to its casting using a wrench. The adjustable center is to be locked tight with the locking hand knob.	When the supports are not held tight to the square tube, the reel can move during grinding. Loose centers effect grinding accuracy.

TROUBLESHOOTING CONT.

PROBLEM	POSSIBLE CAUSE	REMEDY	REASON
Reel ground in a concave, convex, or irregular shape, cont.	Rails not straight. Check rail towards the reel side for straightness in the horizontal plane.	Using a three foot long PRECISION straight edge, and feeler gage, check for a maximum of .002 inch [.05 mm] straightness at the front edge of the front rail. Front rail has three adjusting screws. Rear rail has one adjusting screw.	Rail straightness directly affects grind straightness of the outside diameter of the reel in the horizontal plane.
	Rails not straight. Check vertical plane for straightness of rails.	Using a three foot long PRECISION straight edge, and using a feeler gage, check for a maximum of .003 inch [.08 mm] straightness at the top edge of the front rail and rear rail.	This plane is not as critical for reel grinding accuracy, but still must be held to tolerance listed to hold grind straightness of outside diameter of the reel.
	Carriage has varying load in either direction from grinding grit buildup inside the carriage bearings or uneven wear on the bearing outside diameter.	Replace Bearings	Bearings will fail after many hours of use.
	Rails have grinding grit buildup and carriage bearings do not track straight.	Clean rails of grinding grit.	Rails buildup with grit during operation and must be cleaned often.

TROUBLESHOOTING CONT.

PROBLEM	POSSIBLE CAUSE	REMEDY	REASON
Cone shape of reel.	Reel position not parallel to carriage travel.	Use reel alignment gage procedure touching off on reel hub to zero out the reel position from each end. (For more information, see reel setup gage procedure in manual.)	Reel hub has to be parallel to carriage traverse rails so reel is not cone shaped.
Relief grind on the reel blades does not go full length.	Grinding wheel is not correctly dressed.	See the correct grinding wheel dressing procedure on page 15 of the Operator's Manual.	If grinding wheel is improperly dressed it will not grind approximately the last 3/8" of the blade.
Blades are turning blue during grinding.	Removing too much material in one pass.	Adjust the horizontal infeed to remove less material per pass.	Heavy material removal builds up heat and turn the blade blue.

--This page left blank intentionally, for note taking purposes--

EXPLODED VIEW: 388 MAIN BASE ASSEMBLY

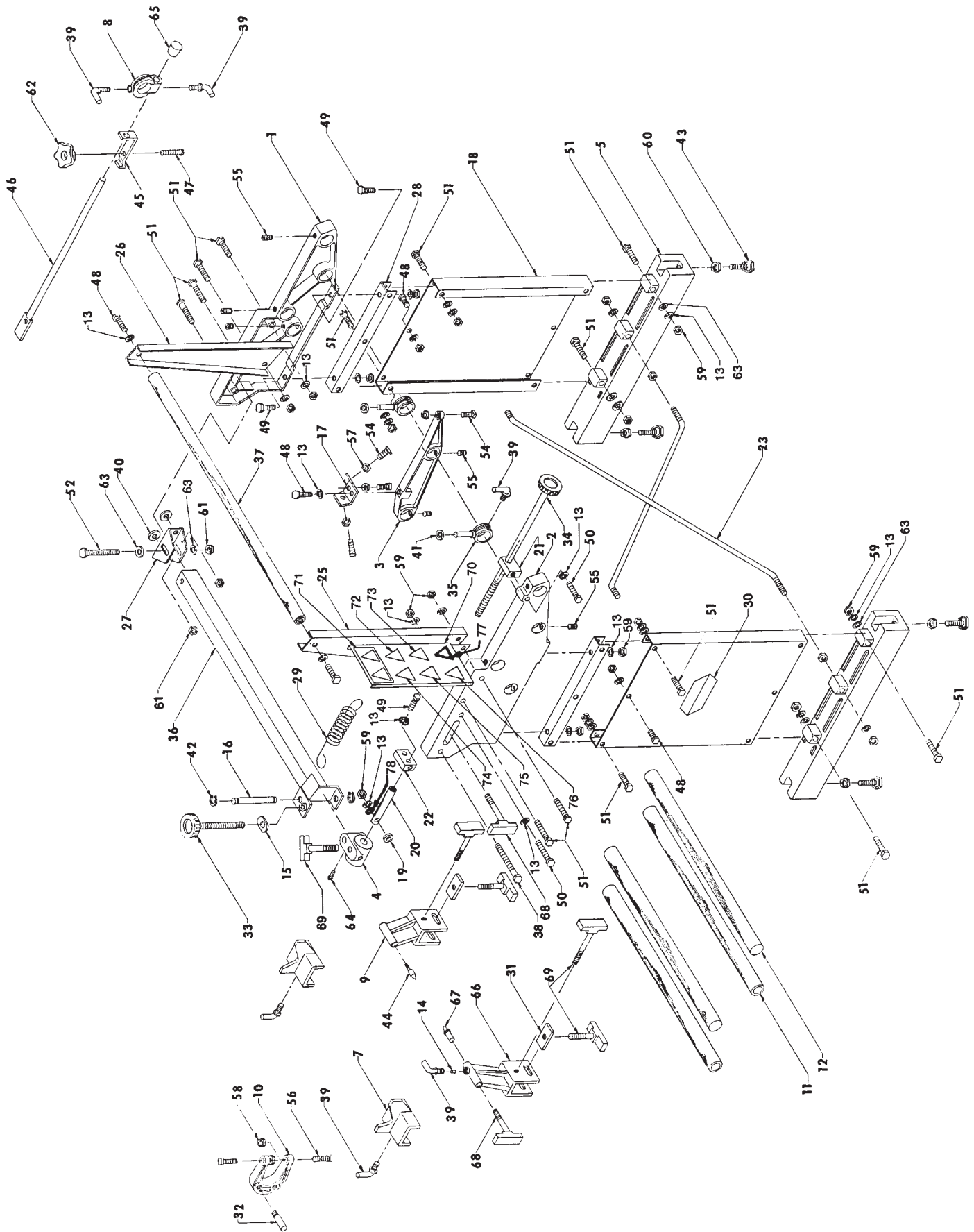


DIAGRAM NO. PART NO. PART NAME

1	3889001	Right-Hand End Frame
2	3889002	Left-Hand End Frame
3	3889003	Strut
4	3969012	Cross Slide
5	3889009	Base
7	3889014	Roller Bracket
8	3889015	Overhead Clamp
9	3889016	Center Stand - Fixed
10	3889017	"C" Clamp
11	3889031	Frame Tie Bar
12	3889032	Carriage Rail
13	K371501	Lockwasher 3/8
14	3579109	Nylon Plug
15	3889035	Lock
16	3889039	Clevis Pivot Pin
17	3889041	Adjusting Bracket
18	3889043	End Frame Panel
19	3889045	Spacer
20	3889046	Cross Slide Shaft
21	3889047	Guide Block
22	3889048	Support Block
23	3889049	Tie Rod
25	3889051	Left-Hand Overhead Support Arm
26	3889052	Right-Hand Overhead Support Arm
27	3889053	"L" Bracket
28	3889054	End Cap
29	3889055	Spring - Support Bar
30	3709990	Decal
31	3889066	Center Stand Lock
32	3889067	Shoulder Pin
33	3889510	Vertical Adjust. Screw Assembly
34	3889511	Horizontal Adjust. Screw Assembly
35	3889514	Carriage Stop Assembly
36	3889521	Tube Weldment
37	3889522	Overhead Bar
38	B375601	Hex Cap Screw 3/8-16 x 3-1/2 Long
39	3709253	Lock Handle
40	3709254	Rubber Washer
41	3709255	Rubber Washer
42	3709331	Retaining Ring

DIAGRAM NO. PART NO. PART NAME

43	3709563	Adjust Leveling Bolt
44	6009517	Center - Fixed
45	3649078	Clamp Lip
46	3969547	Mower Clamp Weldment
47	A313202	Round Head Machine Screw 5/16-18 x 2" Long
48	B371201	Hex Cap Screw 3/8-16 x 3/4" Long
49	B371601	Hex Cap Screw 3/8-16 x 1" Long
50	B373201	Hex Cap Screw 3/8-16 x 2" Long
51	B373601	Hex Cap Screw 3/8-16 x 2-1/4" Long
52	B374801	Hex Cap Screw 3/8-16 x 3" Long
54	C251602	Square Hd Set Screw Oval Point 1/4-20 x 1" Long
55	C370820	Socket Set Screw 3/8-16 x 2-1/2" Long
56	C374000	Square Hd Set Screw 3/8-16 x 2-1/2" Long
57	J251000	Hex Nut 1/4-20
58	J372000	Hex Jam Nut 3/8-16
59	J371000	Hex Nut 3/8-16
60	J501000	Hex Nut 1/2-13
61	J377100	Hex Nut Nylok 3/8-16
62	3708262	Knob 5/16-18 x 1.50 Wide
63	K370001	Plain Washer 3/8
64	R601018	Drive Screws No. 2 Round Head
65	3709258	Bumper
66	3889022	Center Stand - Adjustable
67	6009020	Center - Adjustable
68	6009577	Knob Assy
69	6009555	Knob Assy
70	3889112	Warning Panel
71	3708524	Warning Decal - Glasses
72	3708461	Warning Decal - 3600 RPM
73	3708526	Warning Decal - No Fuel
74	3707458	Warning Decal - Sharp
75	3708525	Warning Decal - Stay Clear
76	3708527	Warning Decal - Respirator
77	3708528	Warning Decal - Hearing Protection
78	K310101	Flat Washer - Heavy

EXPLODED VIEW: 388 GRINDING HEAD ASSEMBLY

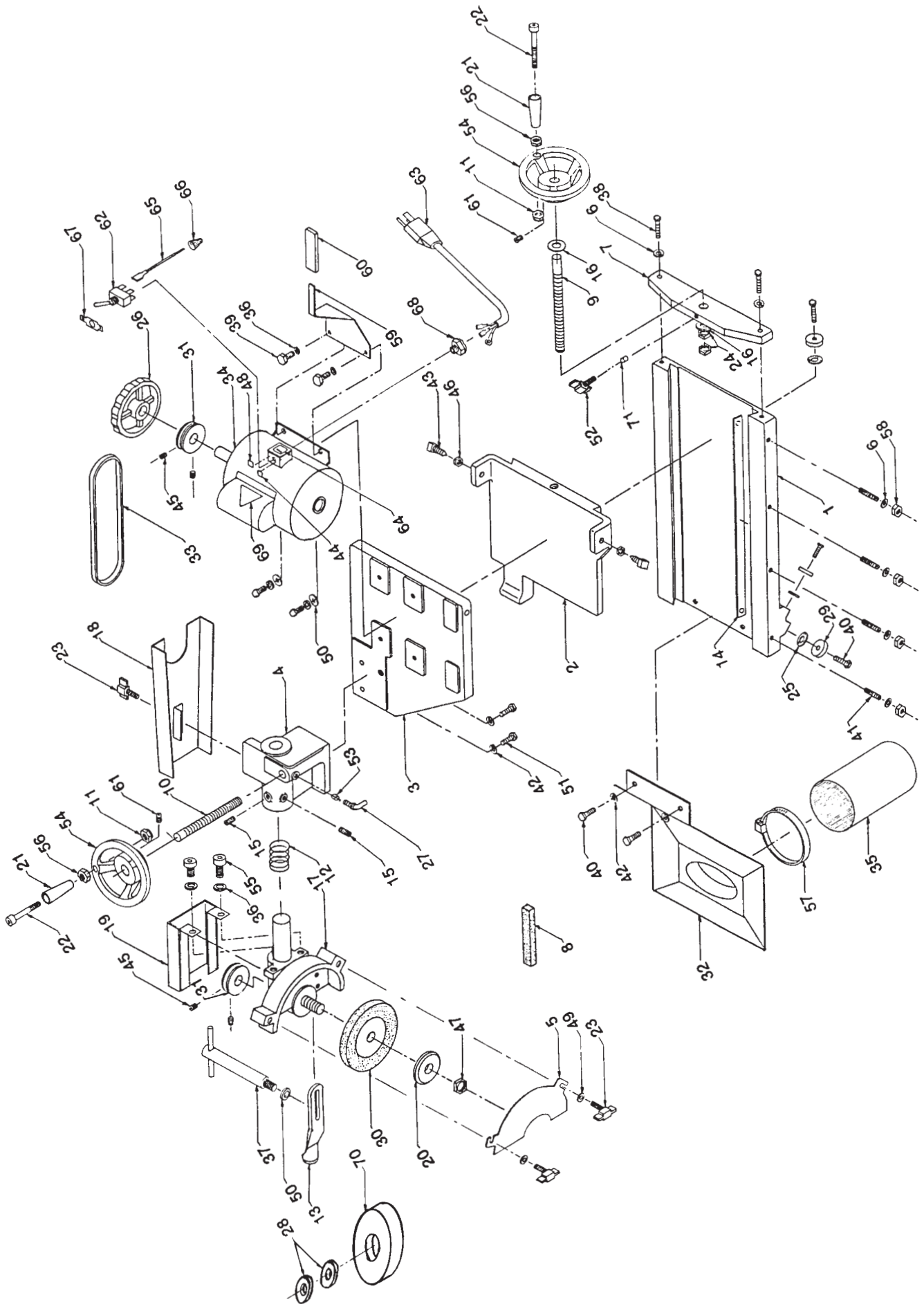


DIAGRAM NO.	PART NO.	PART NAME
1	.3889005	Carriage Base
2	.3889006	Slide
3	.3889007	Motor Plate
4	.3889008	Head Support
5	.6009037	Grinding Wheel Guard
6	.K251501	1/4" Lockwasher
7	.3889136	Feed Screw Guide
8	.3702508	Dressing Stick .75x.75x3"
9	.3889056	Feed Screw
10	.3889057	Elevating Screw
11	.J257000	1/4-20 Locknut - Thin
12	.3889059	Compression Spring
13	.6009133	Reel Guide Finger
14	.6009025	Gib Plate
15	.C310826	5/16-18x1/2 Long Dog Point Setscrew
16	.3709027	Thrust Washer
17	.3889502	Grinding Head Assembly
18	.3889523	Motor Belt Guard
19	.3889509	Grinding Head Belt Guard
20	.3649018	Outer Flange
21	.3709370	Spinning Handle
22	.B255011	1/4-20x3-1/8 Long Socket Head Cap Screw
23	.6009598	Tee Knob Assembly
24	.3709214	Hex Jam Nut 1/2-13 LH
25	.3709216	Retaining Washer
26	.3889098	Handwheel
27	.3709253	Lock Handle
28	.3700408	Reducer Bushing
29	.3709257	Ball Bearing
30	.3700363	Grinding Wheel 6x3/8x1/2 Bore 46 Grit Vitrified Ruby
31	.3889088	Pulley
32	.3889501	Dust Collector
33	.3709764	V - Belt
34	.3707991	Motor 115/220V 60/50HZ 1 Phase
35	.3708146	Dust Bag
36	.K311501	5/16 Lockwasher
37	.6009535	Tee Handle Assembly
38	.B251601	Hex Head Cap Screw 1/4-20x1" Long
39	.B311401	Hex Head Cap Screw 5/16-18x7/8" Long
40	.B371201	Hex Head Cap Screw 3/8-16x3/4" Long

DIAGRAM NO.	PART NO.	PART NAME
41	.C252420	Socket Setscrew 1/4-20x1-1/2" Long
42	.K371501	3/8" Lockwasher
43	.C372000	Square Head Setscrew 3/8-16x1-1/4" Long
44	.3708460	Start Decal
45	.C250620	Socket Setscrew 1/4-20x3/8" Long
46	.J372000	3/8-16 Hex Jam Nut
47	.J502100	1/2-20 Hex Jam Nut
48	.3708459	Emergency Stop Decal
49	.K250001	1/4" Flat Washer
50	.K310001	5/16" Flat Washer
51	.B371601	Hex Head Cap Screw 3/8-16x1" Long
52	.6109597	Tee Knob Assembly
53	.3579109	Nylon Plug 3/16"
54	.3708155	Hand Wheel
55	.B310811	Socket Head Cap Screw 5/16-18x1/2" Long
56	.J252000	1/4-20 Hex Jam Nut
57	.3709804	Hose Clamp
58	.J251000	1/4-20 Hex Nut
59	.3889110	Carriage Handle Bracket
60	.3709624	Plastic Handle
61	.C310420	Socket Setscrew 5/16-18x1/4" Long
62	.3707070	Toggle Switch
63	.3707034	Cord Set
64	.3707130	Warning Decal
65	.3707188	Wire Assembly
66	.3707264	Wire Nut
67	.3707316	On-Off Switch Plate
68	.3707976	Conduit Connector
69	.3708448	Warning Decal - Electrical
70	.3700265	Grinding Wheel 6x1x1.25 Bore 60 Grit Straight Cupped Vitrified Ruby
71	.3579284	Nylon Plug 1/8"
**	.3700067	Grinding Wheel 6-4x1x1.25 Bore 60 Grit Flared Cupped Vitrified Ruby
**	.3700266	Grinding Wheel 6x1x1.25 Bore 46 Grit Straight Cupped Vitrified Grey
**	OPTIONAL	

PARTS LIST: 388 ELEVATOR ASSEMBLY

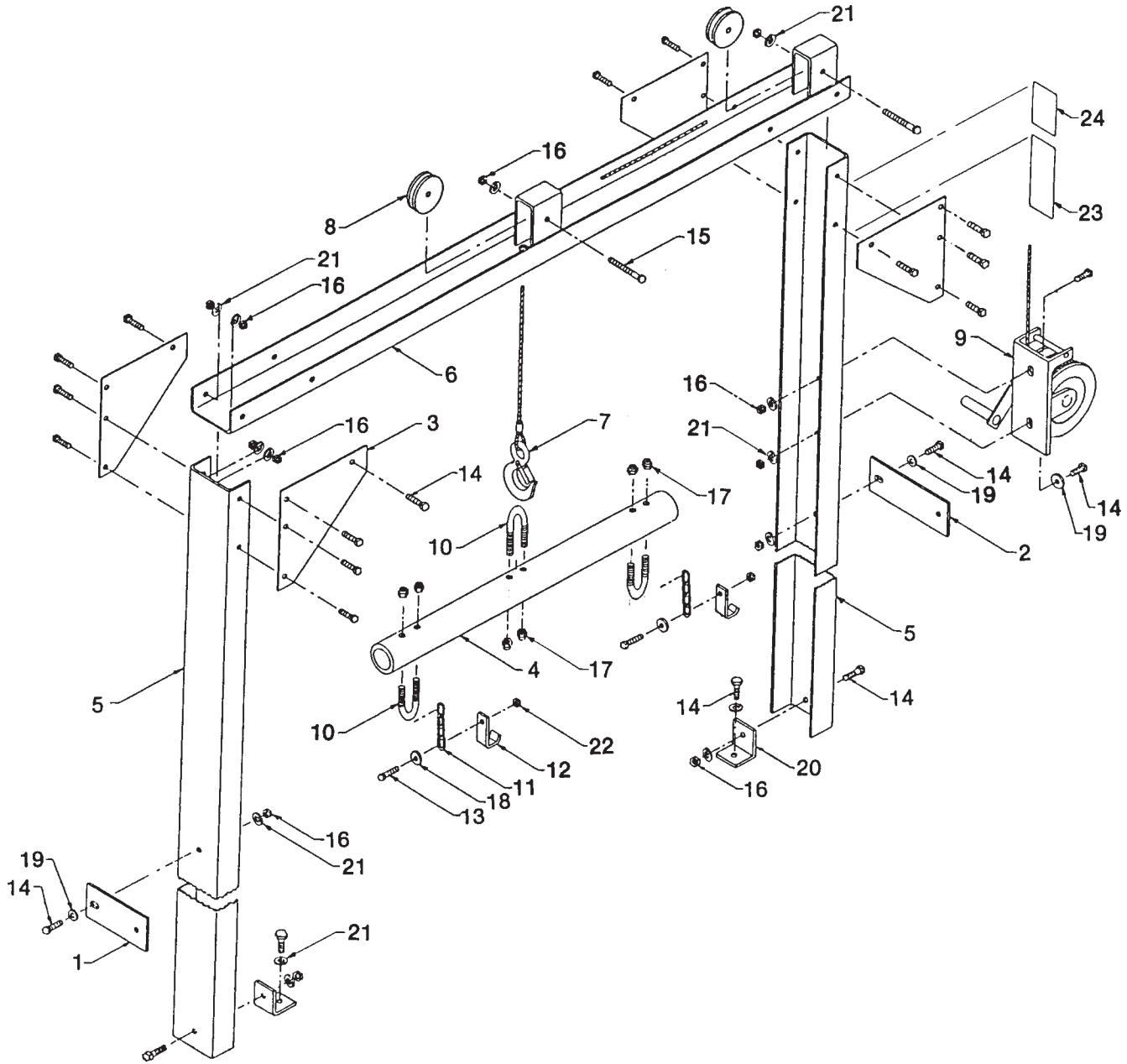


DIAGRAM NUMBER	PART NUMBER	PART NAME
1	3889068	Anchor Strap
2	3889069	Anchor Strap
3	3889071	Gusset
4	6009011	Spreader
5	6009166	End Frame
6	3889526	Overhead Channel Weldment
7	3709407	Hook and Cable Assembly
8	3709795	Pulley
9	3709796	Winch
10	3709316	"U" Bolt
11	3649005	Chain
12	6009102	Grab Hook
13	B371601	Hex Cap Screw 3/8-16 x 1.00 Long
14	B371201	Hex Cap Screw 3/8-16 x 3/4" Long
15	B372801	Hex Cap Screw 3/8-16 x 1-3/4" Long
16	J371000	Hex Nut 3/8-16
17	J317100	Hex Nut Nylok 5/16-18
18	R000453	Plain Washer
19	K370001	Plain Washer 3/8
20	3889074	Angle Tab
21	K371501	Lock Washer 3/8
22	J377100	Hex Nut Nylok 3/8-16
23	6009099	Winch Warning Decal
24	3708449	Winch Warning Decal - Symbol

MODEL 388 ALIGNMENT GAGE ASSEMBLY

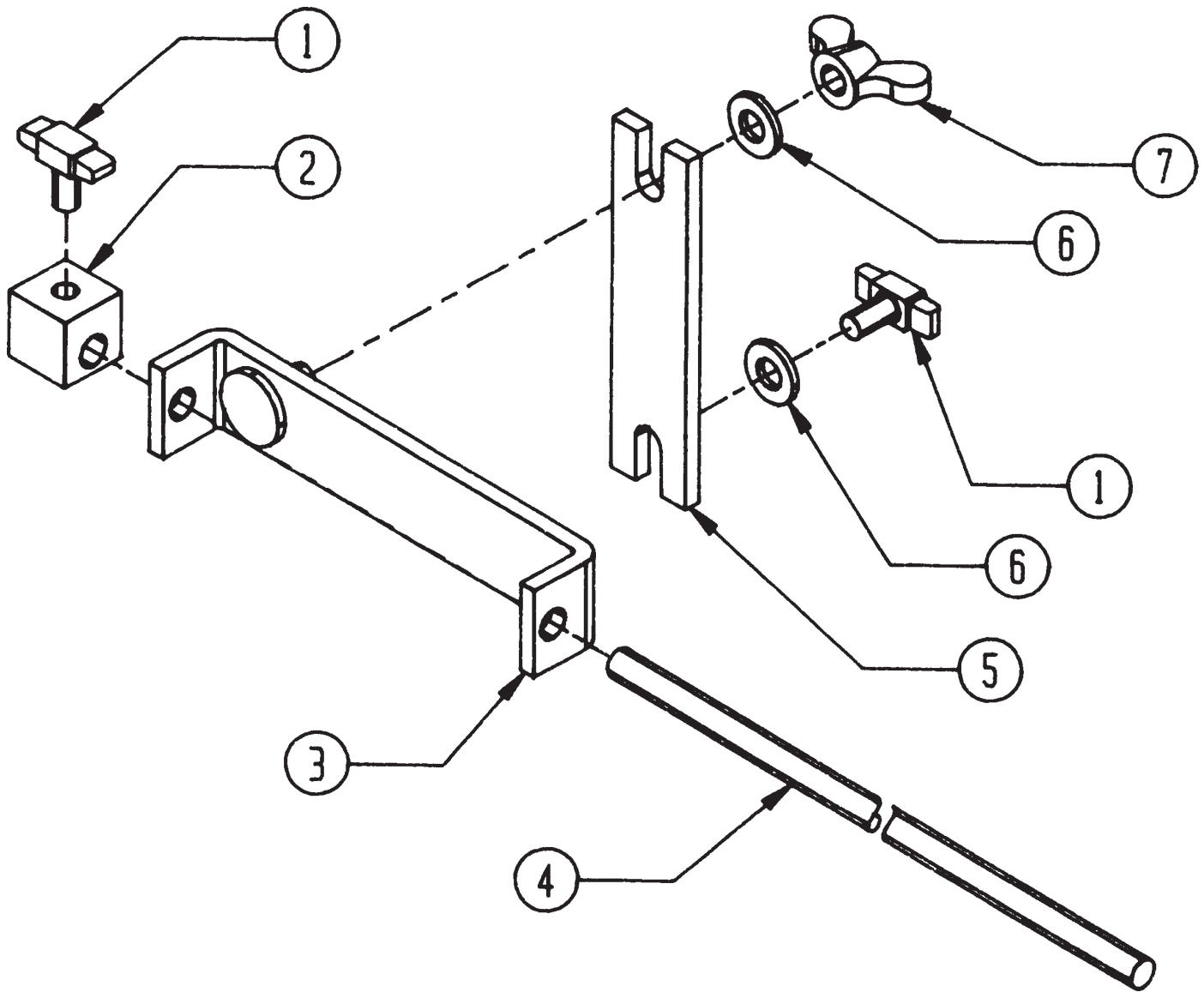


DIAGRAM NO.

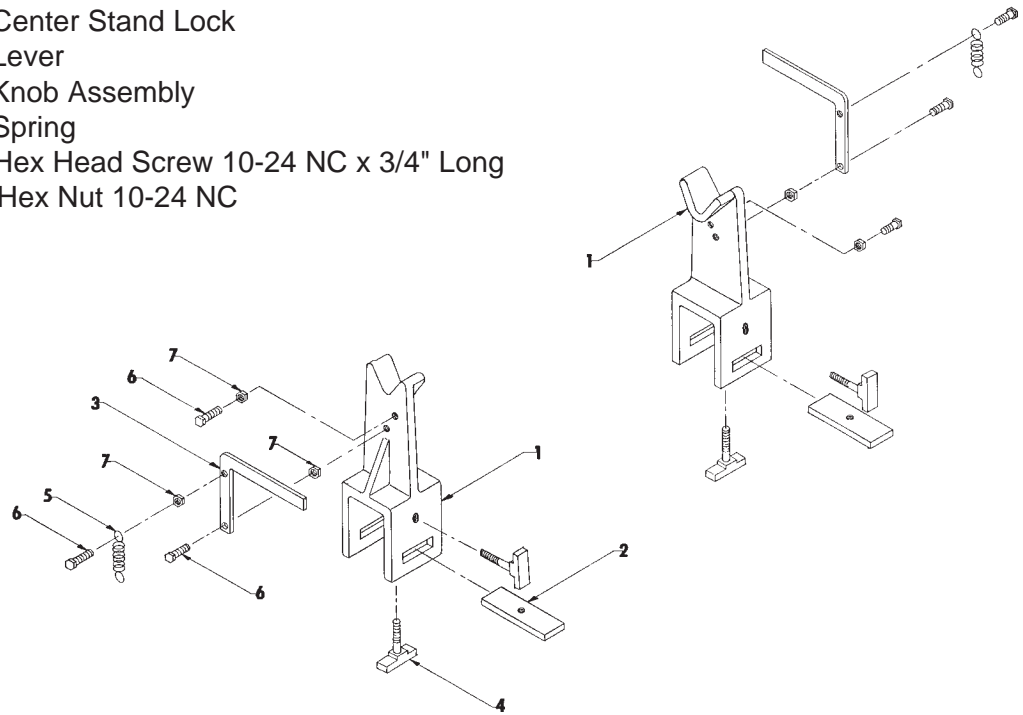
PART NO.

PART NAME

1	6009598	Tee Knob Assembly
2	3109022	Stop Block
3	3889540	Gage Yoke Weldment
4	3889094	Alignment Rod
5	3889096	Gage Bracket
6	K3100015/16 Flatwasher
7	R0004485/16-18 Wingnut

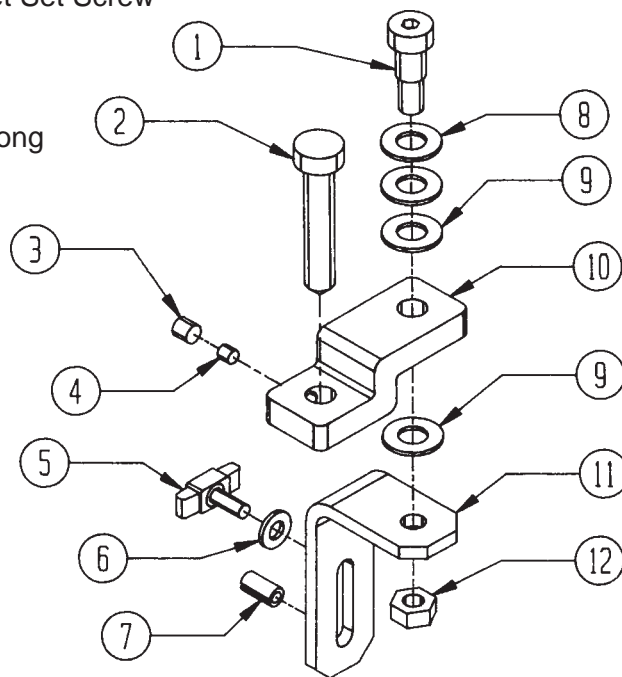
PARTS LIST FOR --OPTIONAL-- 3880932 REEL HOLDER ATTACHMENT

DIAGRAM NO.	PART NO.	PART NAME
1	3889021	Reel Holder
2	3889066	Center Stand Lock
3	3649061	Lever
4	6009555	Knob Assembly
5	3709843	Spring
6	B191201	Hex Head Screw 10-24 NC x 3/4" Long
7	J191000	Hex Nut 10-24 NC



PARTS LIST FOR --OPTIONAL-- 6000560 DIAMOND DRESSER ATTACHMENT

DIAGRAM NO.	PART NO.	PART NAME
1	3708158	.375 Dia x .50 Long Shoulder Bolt
2	6109015	Diamond Dresser
3	C250424	1/4-20 x 1/4 Long Socket Set Screw
4	3579109	Nylon Plug
5	6009598	Tee Knob Assembly
6	K250001	1/4 Flatwasher
7	3708159	Spiral Pin 1/4 Dia x .50 Long
8	3708214	Conical Washer
9	3709304	Thrust Washer
10	6009143	Dresser Arm
11	6009139	Dresser Bracket
12	J317000	5/16-18 Locknut



NOTE: This Dresser is used on machine with a serial No. higher than 1359. Use Dresser 3880929 on machines serial No. 1358 and lower.

--This page left blank intentionally, for note taking purposes--

