

MODEL 377 ROTARY BLADE GRINDER

OPERATORS MANUAL

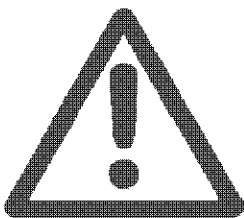

WARNING

You must thoroughly read and understand this manual before operating the equipment, paying particular attention to the Warning & Safety instructions.

SAFETY INSTRUCTIONS

Safety Awareness Symbols are inserted into this manual to alert you to possible **Safety Hazards**. Whenever you see these symbols, follow their instructions.

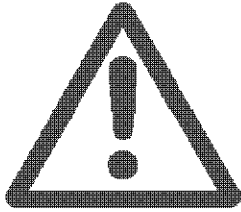

The **Warning Symbol** identifies special instructions or procedures which, if not correctly followed, could result in personal injury.



The **Caution Symbol** identifies special instructions or procedures which, if not strictly observed, could result in damage to or destruction of equipment.

1. **KEEP GUARDS IN PLACE** and in working order.
2. **REMOVE WRENCHES AND OTHER TOOLS.**
3. **KEEP WORK AREA CLEAN.**
4. **DON'T USE IN DANGEROUS ENVIRONMENT.** Don't use grinder in damp or wet locations, or expose it to rain. Keep work area well lighted.
5. **KEEP ALL VISITORS AWAY.** All visitors should keep a safe distance from work area.
6. **MAKE WORK AREA CHILD-PROOF** with padlocks or master switches.
7. **DON'T FORCE THE GRINDER.** It will do the job better and safer if used as specified in this manual.
8. **USE THE RIGHT TOOL.** Don't force the grinder or an attachment to do a job for which it was not designed.
9. **WEAR PROPER APPAREL.** Wear no loose clothing, gloves, neckties, or jewelry which may get caught in moving parts. Nonslip footwear is recommended. Wear protective hair covering to contain long hair.
10. **ALWAYS USE SAFETY GLASSES.**
11. **DO NOT OVERREACH.** Keep proper footing and balance at all times.
12. **MAINTAIN GRINDER WITH CARE.** Follow instructions in this manual for lubrication and preventive maintenance.
13. **DISCONNECT POWER BEFORE SERVICING,** or when changing the grinding wheel.
14. **REDUCE THE RISK OF UNINTENTIONAL STARTING.** Make sure the switch is OFF before plugging in the grinder.
15. **CHECK DAMAGED PARTS.** A guard or other part that is damaged or will not perform its intended function, should be properly repaired or replaced.
16. **NEVER LEAVE GRINDER RUNNING UNATTENDED. TURN POWER OFF.** Do not leave grinder until it comes to a complete stop.
17. **KNOW YOUR EQUIPMENT.** Read this manual carefully. Learn its application and limitations as well as specified potential hazards.
18. **KEEP ALL SAFETY DECALS CLEAN AND LEGIBLE.** If safety decals become damaged or illegible for any reason, replace immediately. Refer to replacement parts illustrations in this manual for the proper location and part numbers of safety decals.
19. **DO NOT OPERATE THE GRINDER WHEN UNDER THE** influence of drugs, alcohol, or medication.

SAFETY INSTRUCTIONS

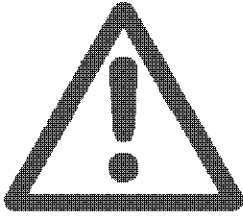

IMPROPER USE OF GRINDING WHEEL MAY CAUSE BREAKAGE AND SERIOUS INJURY.

Grinding is a safe operation if the few basic rules listed below are followed. These rules are based on material contained in the ANSI B7.1 Safety Code for "Use, Care and Protection of Abrasive Wheels". For your safety, we suggest you benefit from the experience of others and carefully follow these rules.

DO

1. **DO** always **HANDLE AND STORE** wheels in a **CAREFUL** manner.
2. **DO VISUALLY INSPECT** all wheels before mounting for possible damage.
3. **DO CHECK MACHINE SPEED** against the established maximum safe operating speed marked on wheel.
4. **DO CHECK MOUNTING FLANGES** for equal and correct diameter.
5. **DO USE MOUNTING BLOTTERS** when supplied with wheels.
6. **DO** be sure **WORK REST** is properly adjusted.
7. **DO** always **USE A SAFETY GUARD COVERING** at least one-half of the grinding wheel.
8. **DO** allow **NEWLY MOUNTED WHEELS** to run at operating speed, with guard in place, for at least one minute before grinding.
9. **DO** always **WEAR SAFETY GLASSES** or some type of eye protection when grinding.

DON'T

1. **DON'T** use a cracked wheel or one that **HAS BEEN DROPPED** or has become damaged.
2. **DON'T FORCE** a wheel onto the machine **OR ALTER** the size of the mounting hole - if wheel won't fit the machine, get one that will.
3. **DON'T** ever **EXCEED MAXIMUM OPERATING SPEED** established for the wheel.
4. **DON'T** use mounting flanges on which the bearing surfaces **ARE NOT CLEAN, FLAT AND FREE OF BURRS**.
5. **DON'T TIGHTEN** the mounting nut excessively.
6. **DON'T** grind on the **SIDE OF THE WHEEL** (see Safety Code B7.2 for exception).
7. **DON'T** start the machine until the **WHEEL GUARD IS IN PLACE**.
8. **DON'T JAM** work into the wheel.
9. **DON'T STAND DIRECTLY IN FRONT** of a grinding wheel whenever a grinder is started.
10. **DON'T FORCE GRINDING** so that motor slows noticeably or work gets hot.

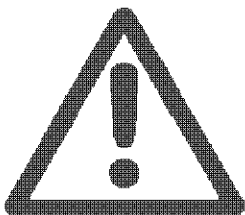

AVOID INHALATION OF DUST generated by grinding and cutting operations. Exposure to dust may cause respiratory ailments. Use approved NIOSH or MSHA respirators, safety glasses or face shields, and protective clothing. Provide adequate ventilation to eliminate dust, or to maintain dust level below the Threshold. Limit Value for nuisance dust as classified by OSHA.

SAFETY INSTRUCTIONS

This machine is intended for rotary blade grinding ONLY. Any use other than this may cause personal injury and void the warranty.

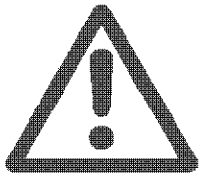

To assure the quality and safety of your machine and to maintain the warranty, you **MUST** use original equipment, manufacturers replacement parts and have any repair work done by a qualified professional.

ALL operators of this equipment must be thoroughly trained **BEFORE** operating the equipment.

Do not use compressed air to clean grinding dust from the machine. This dust can cause personal injury as well as damage to the grinder.

MACHINE SPECIFICATIONS

Motor	1.00 HP 115/220 Volt 60/50 Cycle, 1 Phase
Grinding Wheel	8" Diameter x 1.00" Wide - 24 Grit
Maximum Blade Length	Any Length
Sound Level	Greater than 85 Dba when operating.



Symbol for emergency stopping the machine. Flip the toggle switch to this side.



Symbol identifying a panel, cover, or area as having live electrical components within.

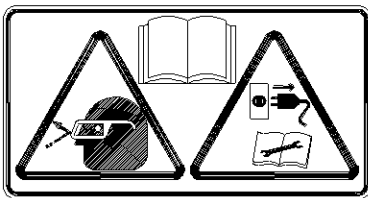

Symbols for Read operators manual, wear safety glasses and disconnect power before servicing.



Symbol for hearing protection required when operating this machine



Symbol for caution relating to RPM of the motor and minimum safe rated RPM of the grinding wheel.

OPERATING INSTRUCTIONS

Follow these instructions, to correctly sharpen Rotary Lawn Mower Blades.

1. CLEANING

A rotary mower blade which has a buildup of dirt and dried grass clippings cannot be properly sharpened or balanced.

To clean your blade follow these steps:

1. Put on safety glasses.
2. Scrape off the heavy grass buildup with a flat scraper.
3. Use a wire wheel on a bench grinder or a wire brush by hand to finish cleaning.

2. INSPECT THE BLADE

If the blade is bent, twisted, or cracked, it must be replaced. See FIG. 1.

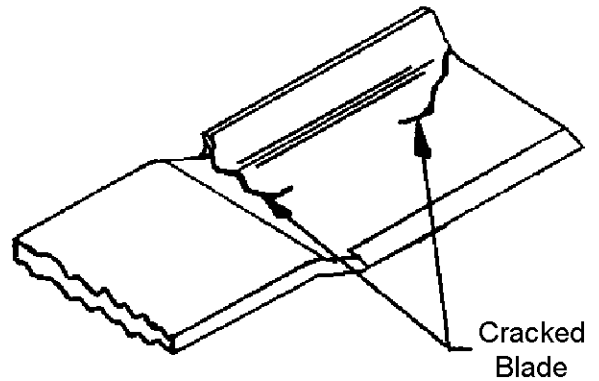
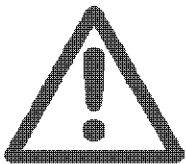
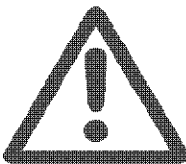

FIG. 1



DO NOT ATTEMPT TO STRAIGHTEN OR REPAIR A BENT, CRACKED, OR TWISTED BLADE. THE USE OF SUCH A BLADE COULD PRESENT A SERIOUS SAFETY RISK.

3. GRINDING



READ AND FOLLOW ALL SAFETY PROCEDURES ON PAGES TWO AND THREE.

- A. With the motor off, adjust the depth control knob assembly until the wheel surface is in contact with the rotary mower blade. See FIG. 3. Match to the cutting edge whenever possible. The cutting edge angle should be approximately 30°. If it is not, adjust the depth control until the desired bevel is achieved.

NOTE: Because of the relationship of the grinding wheel to the grinder base during grinding, this grinder will give a slightly concave surface. See FIG. 2. This is normal and acceptable.

- B. Turn on the motor, with the grinding wheel rotation so the grinding wheel turns toward the blade. See FIG. 2.

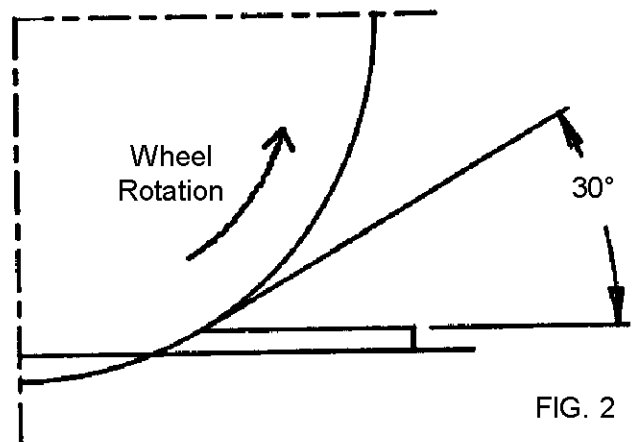

FIG. 2

OPERATING INSTRUCTIONS (Continued)

C. Holding the blade, slide the blade in and out under the grinding wheel. See FIG. 3.

NOTE: If the blade is burning or blueing while sharpening, use lighter strokes. Also, keep the grinding wheel dressed and clean at all times to prevent heat buildup. A grinding wheel slightly rounded on the edge should run a little cooler than one dressed flat. The Optional Dressing Stick is Part No. 3702508 -- .75 x .75 x 3.00 inches.

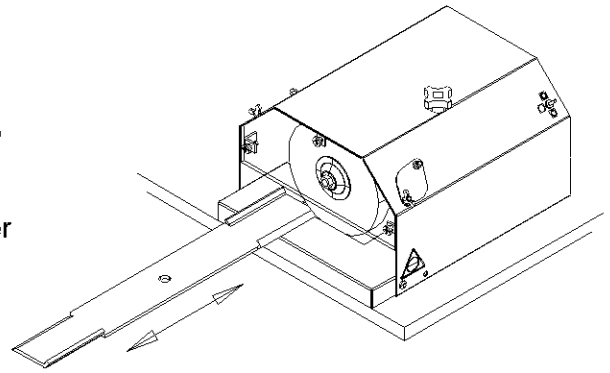

FIG. 3

D. Grind the blade the same amount at each end. Use slow, even passes under the grinding wheel. The cutting edge angle should be about 30° after grinding. Several passes are generally necessary to clean up the cutting edge of the blade.

NOTE: A 30° bevel on the sharpened edge is an ideal bevel--a 15° bevel would be too sharp and dull very rapidly. A 45° bevel is too blunt. See FIG. 4.

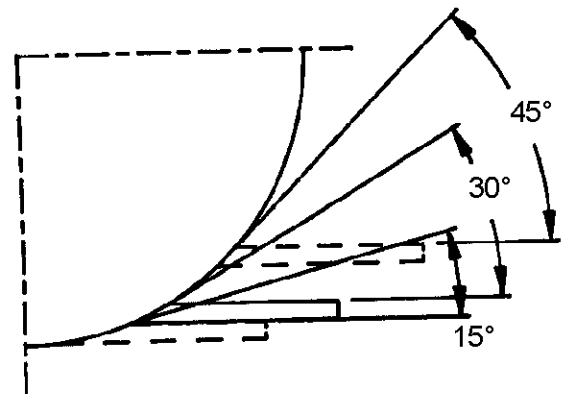

FIG. 4

E. When the blade has been sharpened, stroke a flat file across the bottom of the cutting edge to remove any burr buildup. See FIG. 5.

F. BLADES WITH NONPARALLEL CUTTING EDGE AND "S" STYLE BLADES

Rotary mower cutting blades with the cutting edge at an angle to the body of the blade and "S" style blades must be ground by holding the blade in the same way as shown in FIG. 3 except the blade must be held at an angle to the grinding wheel. This will permit the cutting edge of the blade to be at a right angle to the grinding wheel. By maintaining this angle and sliding the blade in and out under the grinding wheel, a uniform cutting edge will be ground.

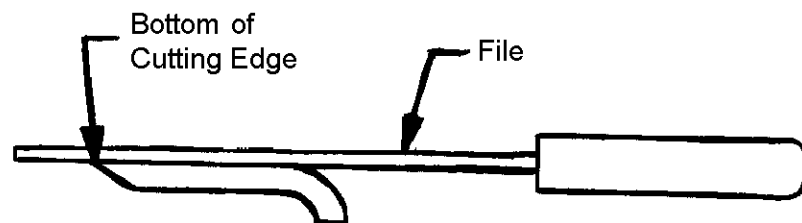

FIG. 5

OPERATING INSTRUCTIONS (Continued)

WHEN BALANCING THE BLADE

- A. Check the balance of the blade by placing it on the balancer. The blade need not be perfectly balanced. If the blade is held level and after releasing, the end drops less than 1", the balance is satisfactory for ordinary use on most rotary lawn mowers.
- B. Ordinarily the blade can be balanced by grinding just the cutting edge of the heavier end. However, if the blade is badly out of balance, the blade should be balanced by grinding in the area shown in FIG. 6.

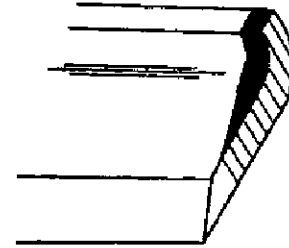

FIG. 6

DAILY MAINTENANCE

On a weekly basis, clean the rotary blade grinder by wiping it off.

On a weekly basis, inspect the grinder for loose fasteners or components.

Approximately every 40 hours of operation, remove the front blade support base and grinding wheel. Then clean the inside of the grinder by wiping it off.



**DO NOT USE COMPRESSED AIR TO
CLEAN GRINDING DUST FROM GRINDER.**

