

SALSCO, INC.

LEADER BY DESIGN

OPERATORS AND PARTS MANUAL
MODEL 09005 BALE WRAPPER & MODEL 09023 ECONO-WRAP

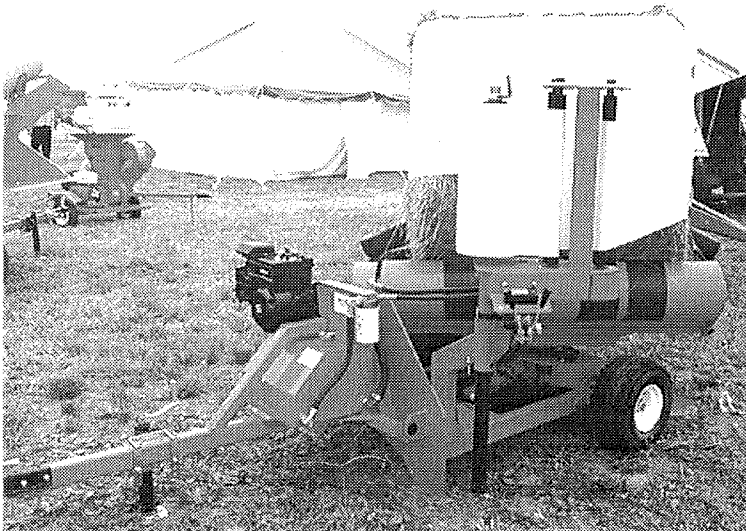

3-POINT HITCH MODEL SHOWN WITH
POWER PACK OPTION

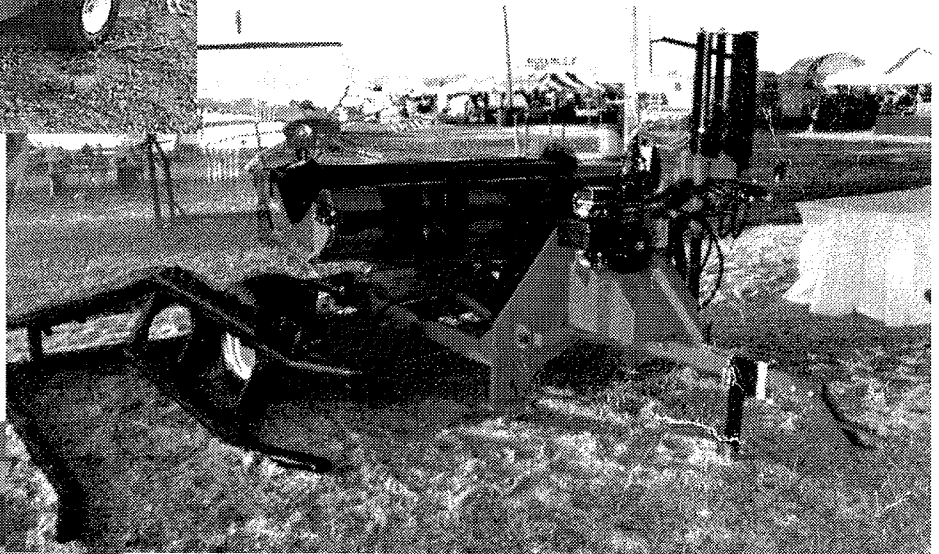

3-POINT HITCH MODEL SHOWN WITH POWER PACK AND LIFT
ARM OPTION

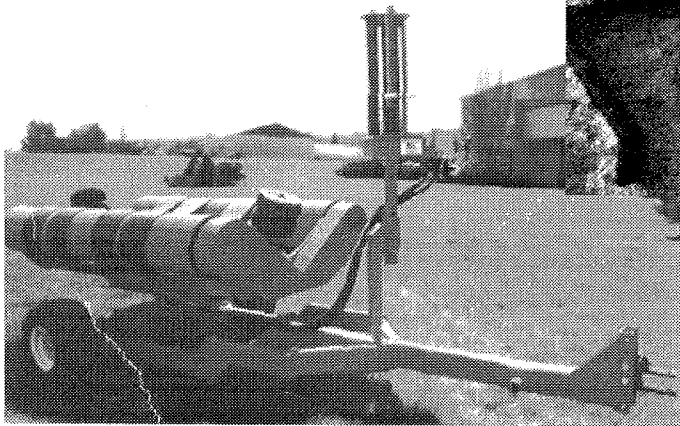

MODEL 09023 - *Econo-Wrap*

SALSCO, INC.

105 School House Road, Cheshire, CT 06410. 203/271-1682, 800/872-5726, 203/271-2596 (fax)

5/8/95

TABLE OF CONTENTS

STATEMENT OF FACT	Page 1
DESCRIPTION	Page 2
SPECIFICATIONS & OPTIONS	Page 3
MACHINE REGISTRATION	Page 4
MAINTENANCE & OPERATING INSTRUCTIONS.....	Pages 5 - 10
COPIES OF SAFETY DECALS	Page 11
PLASTIC WRAP DISPENSING DIAGRAM	Page 12
POWER BEYOND ADAPTOR INSTALLATION	Page 12
PARTS DIAGRAMS	Pages 13 - 20
WARRANTY POLICY AND PROCEDURE	Page 21
COPIES OF WARRANTY CLAIM & DEALER DELIVERY REPORT	Pages 22 - 23
SERVICE SCHEDULE LOG	Page 24

STATEMENT OF FACT

You have just purchased the highest quality, most dependable Bale Wrapper on the market today. This unit has the ability to meet exact standards and perform for years with minimum down time. HOWEVER, it cannot read nor will it understand this manual, no matter how long you leave it on top of the machine. It is your responsibility to read and understand it. It is also your responsibility to be certain this information is passed along to anyone who is expected to operate this equipment. Should you choose not to read, understand and pass along the information provided you, please expect equipment failure and possible injuries to persons around this equipment.

For the safety of the operator, it is imperative that this manual is carefully read and understood.

Having read this manual, it is your responsibility to be sure that all new operators read and understand this manual, especially all the cautions stated.

As a manufacturer of equipment we have a responsibility to design a safe piece of equipment. **NOTE:** The important safeguards and instructions in this manual are not meant to cover all possible conditions and situations that may occur. It must be understood that common sense, caution, and care are factors which cannot be built into any product. These factors must be supplied by the person(s) caring for and operating this equipment

REMEMBER - ONLY YOU CAN PREVENT ACCIDENTS!

DESCRIPTION

The Salsco Bale Wrapper is a simple, inexpensive alternative to bale wrappers costing several thousand dollars more. We went back to basics with this one and built from there. Our 3-point hitch standard model will wrap 4' or 5' wide bales. We have the best of both worlds with Dual Drive Rolls and 4 Bra Belts to hold loose bales up and keep them from sagging. Part of the standard package on all units is a Counter, which counts the number of wraps. This feature adds consistency and saves on the cost of plastic. We have either open or closed hydraulic valves available so that we can connect with any hydraulic feed source which will supply 7 G.P.M. or above.

Our list of options fit, as always, even the first machines we've built, allowing a customer to add to his machine and build as he chooses. We have, as an option, Wheels and a Tow Hitch which allow the customer to move the bale wrapper with any tow vehicle. Our Power Pack option allows the customer to tow the bale wrapper with an old pick up truck to the field, or to where you're going to store wrapped bales. Pull the rope on the 5 h.p. Briggs & Stratton or 5.5 h.p. Honda engine and this self contained bale wrapper is ready for work, freeing up your 60 - 80 h.p. tractor which would normally be used to move the bale wrapper. Other options include a Lift Arm and Cut and Tie setup, complete with Hitch, Large Tires and Jack Stand. This unit allows the operator to go to the field, pick up and wrap bales from beginning to end, without leaving the tractor.

The heart of any bale wrapper is the Pre-Tensioner. Our Pre-Tensioner is fully mechanical and will stretch the plastic wrap a full 50%. Unlike some others on the market, our stretching takes place between the last two rolls and is exact! Whether you start with a new roll of film or it's the last 50' of film, you can count on the Salsco Pre-Tensioner. Also available as an option, is a fully mechanical 30" Pre-Tensioner.

Whatever your operation and preferences for wrapping high quality baleage, Salsco has the answer. Built to last with 1/2" steel plate and 1/2" square tubing, this unit will not bend or twist while wrapping the heaviest of bales. Powder coated baked enamel paint, withstands even the harshest conditions. The Salsco Bale Wrapper will perform efficiently and trouble free for many years to come, giving the farmer a piece of equipment which will benefit his or her operation and increase profit dollars.

SALSCO PRODUCTS ARE MADE IN THE U.S.A.

BALE WRAPPER SPECIFICATIONS & OPTIONS

MODEL 09005, 3-POINT HITCH

- * ROLLS: (2) Dual drive rolls. 1/4" wall, 10 3/4" O.D. tubing, 1 1/4" shaft and two (2) bolt cast iron flange bearings
- * BELTS: 4 bra belts - 7" wide (adjustable for 4' or 5' bales)
- * CHAIN: #50 chain on turntable
- * CENTER PIN: 2" center pin with tapered roller bearings
- * HYDRAULIC MOTOR CONTROLS - tilt & wrapping speed are controlled from operator position
- * PRE-TENSIONER: exact 55% stretch at all times during wrapping procedure, NO ADJUSTMENT EVER needed! Pivots for storage and transport and is adjustable for height of bale, no tools required. Tilt down for ease of installing plastic.
- * GUIDE WHEELS: Wheels on table are adjustable for 4' or 5' bales
- * HYDRAULIC TANK: 15 Gallon capacity
- * CONSTRUCTION: 1/2" steel plate and 1/2" square tubing, gusseted and continuous welds where needed
- * HAY GUARD: Standard
- * DIMENSIONS: Weight - 1400 lbs., Height - 47" (not including tensioner), Length - 86"

OPTIONS - MODEL 09005

- * Power pack - 5 h.p. Briggs & Stratton or 5.5 h.p. Honda engine
- * Power pack bracket - for mounting engine to wrapper with standard 3-point hitch
- * Draw bar hitch
- * Transport tires - 18.5 x 8.5 - 8 (6 ply)
- * Jack stand
- * Flow control valve for open or closed hydraulic systems
- * 30" Pre-tensioner
- * Automatic Cut & Tie assembly complete with hydraulic cylinder
- * Lit arm - complete with extra large tires, automatic cut & tie, jack stand and hitch
- * Tractor access valve bracket

MODEL 09023, *Econo-Wrap*

- * TOW FRAME: 2" x 4" square tubing.
- * TONGUE: 3" x 4" square tubing.
- * HITCH: Draw bar hitch, adjustable
- * CHAIN: #50 chain on turntable
- * CENTER PIN: 2" center pin with tapered roller bearings
- * TRANSPORT TIRES: 18.5 x 8.5-8. 4 ply.
- * ROLLS: Two (2) - 1/4" wall, 10 3/4" O.D. tubing. 1 1/4" shaft and two (2) bolt cast iron flange bearings
- * BRA BELTS: Four (4) 3/16" thick x 7" wide x 109" long, continuous for strength.
- * GUIDE WHEELS: Four (4). Adjustable for 4' or 5' wide bales.
- * HYDRAULIC MOTOR CONTROLS - tilt & wrapping speed are controlled from operator position
- * HYDRAULIC TANK: 15 Gallon capacity
- * PRE-TENSIONER: exact 55% stretch at all times during wrapping procedure, NO ADJUSTMENT EVER needed! Pivots for storage and transport and is adjustable for height of bale, no tools required. Tilt down for ease of installing plastic.
- * HAY GUARD: Standard
- * DIMENSIONS:

OPTIONS - MODEL 09023

- * Wrap counter
- * Power pack (5.5 hp Honda or 5 hp Briggs & Stratton) No power pack bracket needed.
- * Jack Stand
- * Cut & Tie
- * Lift arm, complete with (2) cylinders, roll over bar, wide tires and automatic cut & tie with cylinder.
- * Tractor access valve bracket
- * 30" Pre-tensioner assembly

Don't forget about the Salsco Bale Grabber, if you haven't already purchased one. This piece of equipment is the most economical and safest way to move wrapped or unwrapped bales!

MACHINE REGISTRATION

MANUFACTURED BY:

SALSCO, INC.
105 School House Road
Cheshire, CT 06410
203/271-1682,
1/800/872-5726,
203/271-2596 (fax)

THIS MANUAL COVERS MODELS: 09005, Bale Wrapper and optional Power Pack and Lift Arm units. Also covered is the Econo-Wrap, Model 09023. Please check your serial number tag for the complete model number and serial number of your machine.

This company reserves the right to discontinue, add improvements to, or change the design of any model or product at any time without obligation to improve existing machines, either by changing the design or adding new parts.

It has been and will continue to be the policy of Salsco to update existing machines at its own discretion. Whenever possible, new designs will be made in such a way, that they can be "retro fit" if so desired.

Record in the space provided below the model and serial number of this unit. Please retain these numbers for future reference.

When placing parts orders, please have this information available. Part numbers are listed in this manual.

SERIAL NUMBER

MODEL NUMBER

NOTE: BE SURE TO COMPLETE YOUR WARRANTY CARD AND RETURN A COPY TO SALSCO. THIS WILL INSURE IMMEDIATE PROCESSING OF ANY WARRANTY CLAIMS.

MAINTENANCE & OPERATING INSTRUCTIONS

Econo Wrap owners (Maintenance & Operating procedures are the same as for 3-Point Hitch Model)

3- POINT HITCH MODEL - (Maintenance)

- * Grease turntable weekly. Remove cover on center tube, below bra belts and grease bearing. Also check bevel gears, at this time, for end-play and grease them with open gear lubrication.

NOTE: Should this bearing need to be replaced for any reason, it should be roll pinned as it was from the factory.

- * Grease four bearing ends of large table rolls weekly.
- * Check chain adjustment on chains under butterfly guard daily.
NOTE: Tip dump table and look under guard to see if chains are loose. If they are, remove guard and adjust before wrapping.
- * Check turn table chain for adjustment, at the same time.

3- POINT HITCH MODEL - (Operation)

- * **READ THIS MANUAL!**
- * Check your tractor manual to see if tractor hydraulics are compatible with wrapper. (Closed or open).
HINT: Should you allow someone to borrow your wrapper, be sure to check this. The Salsco wrapper is available either way. Connect 3-point hitch and hydraulic hoses to tractor.
- * Move wrapper to wrapping location. HINT: This should be where you plan to store bales. It is a lot easier to move unwrapped bales rather than wrapped bales. Wrapped bales should be handled as little as possible to prevent damage to plastic. Wrapping area should be as level and dry as possible.
- * Set unit down firmly on dry, flat ground, for easier and safer wrapping.
- * Pivot pre-tensioner bracket out to the operation position and lock securely with bolts and pins provided.
- * To set this machine for 4' or 5' width bales, move wheel side bumpers in or out as required to achieve 4' or 5' dimension. Bra belts can also be adjusted.
- * Before placing a bale on the wrapper, get familiar with the operation of the control valves. **CAUTION: Keep everyone clear while you're learning the operation of this unit.** Move hydraulic lever marked WRAP, slowly towards you. When you feel comfortable with the lever, you are ready to wrap. NOTE: Units are set so that you cannot go in reverse direction. Going in reverse, can cause serious damage to this unit.

DO NOT OPERATE THIS EQUIPMENT BEFORE READING THIS MANUAL!

MAINTENANCE & OPERATING INSTRUCTIONS (Cont.)

- * Place bale on wrapper, put film on the pre-tensioner. (See pre-tensioner instruction section for information on pre-tensioner)
- * Pull film through pre-tensioner following diagram in this manual and tie to bale.
- * Rotate bale slowly once, and stop. If film is not in center of bale, raise or lower pre-tensioner to suit.
- * Pull handle and rotate bale counter clockwise until there's one layer of plastic covering the bale. **STOP!** Check the counter to see what number is displayed. **EXAMPLE:** Number 12 is showing. You should then wrap till the number 24 or 25 is showing. This would give you double coverage, or 4 layers of film. **HINT:** Put at least 2 layers of film on the bale. Depending on the length of storage time you are trying to achieve, it may be advisable to put on 3 layers of plastic.
- * When bale is wrapped to your specifications, slow down wrap process. Put your finger into the film and make a hole. This will cause the film to break and you can now stuff the end of the plastic into a seam on the bale.
- * Stop rotation of the bale in the dump position. **HINT:** Do not come to stop position suddenly. Start to slow rotation down on last 2-3 wraps. Dump position is with the table facing squarely to the rear of the machine. Slowly move the hydraulic valve marked dump. **CAUTION: Make sure no one is in the dumping area or near the wrapper when you are ready to dump.**
- * You are now ready to wrap another bale. Your tractor should be waiting there with another bale. You now know what number of wraps suits your operation and your whole procedure should take only about 45 - 60 seconds per bale. **HINT:** When storing bales, stack them on end, two high. They will hold their shape better, and take up less room. Again, after wrapping is done, visually inspect bales. Should there be any rips or holes, now is the time to repair them with tape.

3-POINT HITCH WITH POWER PACK - (Maintenance)

- * Maintenance procedures are the same for the power pack unit as for the 3-point hitch model, with the following additions:
- * Check engine manual and follow manufacturers maintenance and operating procedures.
- * Check hydraulic oil monthly and change yearly. Fill tank to 4" below top and use good quality, non-detergent AW-32 weight oil. Be sure to fill the hydraulic filter with oil, before installing a new one. Hydraulic filter should be replaced once every 6 months.

NEVER OPERATE UNIT WITHOUT GUARDS IN PLACE

MAINTENANCE & OPERATING INSTRUCTIONS (Cont.)

3-POINT HITCH WITH POWER PACK - (Operation)

- * Operation of this unit is the same as for the 3-point hitch unit. The only difference with a power pack is that the power pack takes the place of the tractor hydraulics. HINT: Run engine at 1/2 throttle. No more is necessary and this will prolong the life of the engine.
- * Rotate table a couple of times. Be sure air is out of hydraulic system. You are now ready to wrap.

3-POINT HITCH WITH POWER PACK AND TOWING PACKAGE - (Maintenance)

- * Maintenance instructions are the same as listed for the 3-point hitch and power pack units with the following additions:
- * Wheel bearings should be greased every 6 months.
- * Grease fittings for wheel pivot assemblies, every 6 months.

3-POINT HITCH WITH POWER PACK AND TOWING PACKAGE - (Operation)

- * Operation procedures are the same for the power pack and towing package unit as for the 3-point hitch and power pack model, with the following additions:
- * To lower machine for operation: **CAUTION: NO ONE SHOULD BE AROUND OR NEAR UNIT WHEN LOWERING MACHINE FOR OPERATION.** Rotate table so that the butterfly guard is towards the power pack and angle iron end will contact ground when table is dumped.
- * Slowly move dump handle to dump position until angle iron engages ground and begins to raise bale wrapper off the ground.
- * Pull pin on wheel pivot assembly and rotate wheel brackets upward and reinstall pin securely. **CAUTION: DO NOT TRUST MACHINES HYDRAULICS. NEVER GET UNDER UNIT OR ALLOW ANYONE ELSE IN THE IMMEDIATE AREA WHILE YOU'RE PERFORMING THIS OPERATION!**
- * Once you've raised both wheels, move hydraulic lever to tilt table back to the upright position and you will see machine lower to operating position, close to the ground.
- * To convert unit into transport mode, reverse procedure. **AGAIN! CAUTION: DO NOT TRUST MACHINES HYDRAULICS. NEVER GET UNDER UNIT OR ALLOW ANYONE ELSE IN THE IMMEDIATE AREA WHILE YOU'RE PERFORMING THIS OPERATION!** Tilt, raise machine, lower wheels, pin them securely and put table back to upright position.
- * Wheels are not over the road wheels and should not be towed at speeds in excess of 25 M.P.H.

USE CAUTION AT ALL TIMES WHEN HANDLING ROUND BALES!

MAINTENANCE & OPERATING INSTRUCTIONS (Cont.)

3-POINT HITCH UNIT WITH LIFT ARM ATTACHMENT -

(Consists of: 3-Point Hitch Standard Unit, Tow Hitch, Jack Stand, Automatic Cut & Tie, Lift Arm Frame, and Extra Large Tire Package.)

3-POINT HITCH UNIT WITH LIFT ARM ATTACHMENT - (Maintenance, Adjustment, & Operation)

3-Point Hitch Standard Unit - See section titled 3-Point Hitch Unit -

Automatic Cut & Tie -

- * The only maintenance on the Cut and Tie is adjustment, as listed below, and light oil or W-D 40 sprayed from time to time on moving parts
- * To adjust the cut and tie system, you must first go to the cutting assembly that grabs and cuts the plastic.
- * Remove the pin from the clevis end of the cable on the grabber assembly.
- * Manually squeeze the grabber closed. Watch the knife blades. Don't get your fingers in there. The blades should overlap each other with the straight edges closest to each other and the beveled edges farthest away from each other.
- * When you squeeze the grabber closed, the linkage should over center and lock. Change adjustable stop if necessary. **NOTE:** If this procedure is done properly, you should be able to flip the pivoting lever with one finger and this will open the grabber quickly and easily.
- * Leave the grabber in the closed position and keep the clevis from contacting the lever during the next section of adjustment. Remove if necessary.
- * Rotate table till it's in the dump position. This is when the bale roll over bar is parallel with the breast plate of the machine.
- * Dump table slowly, as you would if there was a bale on the unit.
- * Leave table in the dump position and turn off the tractor or power pack engine.
- * Look under the unit and you'll see where the roll has contacted the flipper plate on the machine and has activated the cable to the grabber.

**NEVER PERFORM ADJUSTMENT OR MAINTENANCE WITHOUT
DISCONNECTING AND DISABLING THE POWER SOURCE**

MAINTENANCE & OPERATING INSTRUCTIONS (Cont.)

- * You may have to adjust the cable mounting bracket so that the roll contacts the flipper plate.
- * Look at the cable end, up by the grabber.
- * Adjust the clevis and put the pin in. This position is the most the cable can move to close the grabber hand.
- * Tilt table back to upright position and with one finger, flip lever and see if grabber opens. If not, check over center stop or check cable for binding. If it works, you're ready to wrap a test bale. NOTE: Rotate table slowly to be sure grabber unit doesn't hit the table or pre-tensioner. Adjust grabber bracket if necessary.
- * Pull unit into bale so that the lift arm is under the bale. Raise lift arm slowly so bale will dump onto machine and then lower lift arm completely down and out of the way. **CAUTION: Operate unit on as level and dry a surface as possible. Be sure no one is in the vicinity when lifting bales onto table.**
- * Pull film (see instructions earlier) to grabber hand and manually squeeze hand so it holds the film.
- * Rotate and wrap bale, (see previous instructions). If cut and tie grabber hand is adjusted properly, the tail of the plastic will flip lever and open the hand.
- * When done wrapping, dump bale as previously instructed.
- * Rotate table so that the bale roll over bar is parallel to breast plate and pull dump handle slowly.
- * NOTE: If cut and tie is adjusted properly, the following will happen: The grabber, which is open, will be under the film's path to the bale and when you pull the dump handle the cylinder on the pre-tensioner will activate and the lever will bring the film into the waiting open grabber hand. At this time the table will begin to dump and the roll under the table will contact the flipper and activate the squeezer hand, which will lock up and hold the film and cut the plastic on the bale side when the bale rolls off.
- * Now raise the table back to the upright position and rotate 90 ° so that the roll over bar is opposite the lift arm. NOTE: The grabber hand should be holding the film.
- * Pick up another bale and repeat the process.

READ OPERATORS MANUAL BEFORE OPERATION AND OR MAINTENANCE

MAINTENANCE & OPERATING INSTRUCTIONS (Cont.)

Lift Arm Frame & Tires -

- * There are no grease fittings on this assembly. You should visually inspect all bolts to be sure they have not loosened during operation.
- * Check bushings in the pivot assemblies. These may wear as the years go by. These should be replaced as needed.
- * Adjust arm by pulling the pin and sliding the arm in or out as needed. You will want it as tight as the bale will allow.
- * Wheel bearing should be repacked yearly or as required. NOTE: Tires are not high speed tires and should not exceed towing speeds over 35 M.P.H.

SAFETY - COMMON SENSE - CAUTION

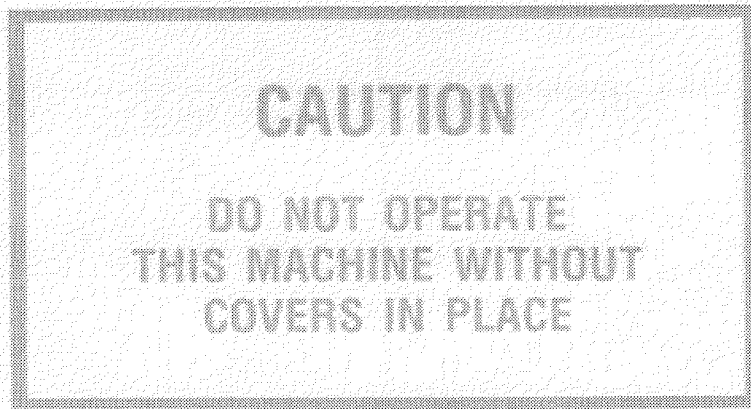

PART # 0314049

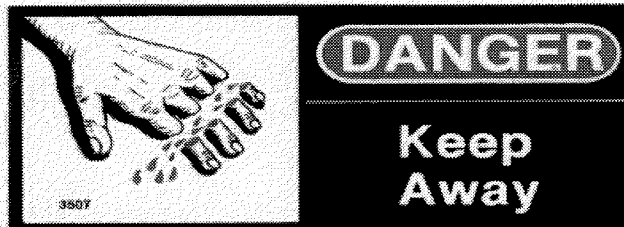

PART # 0314029

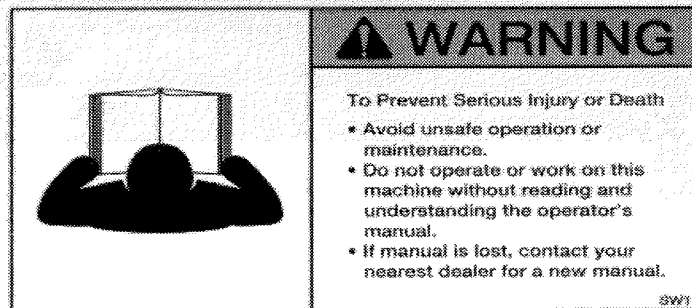

PART # 0314062

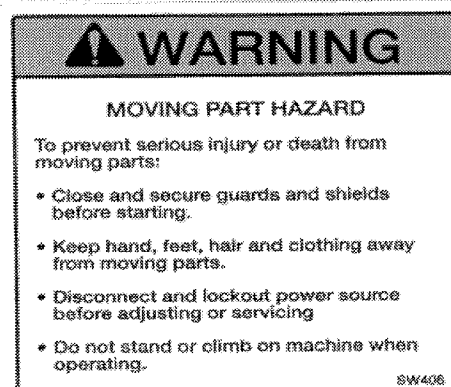

PART # 0314060

SAFETY DECALS ARE AN IMPORTANT PART OF SAFE OPERATION OF ANY EQUIPMENT. SHOULD YOU NEED REPLACEMENT DECALS, PLEASE CONTACT YOUR SERVICING DEALER OR SALSCO DIRECT!

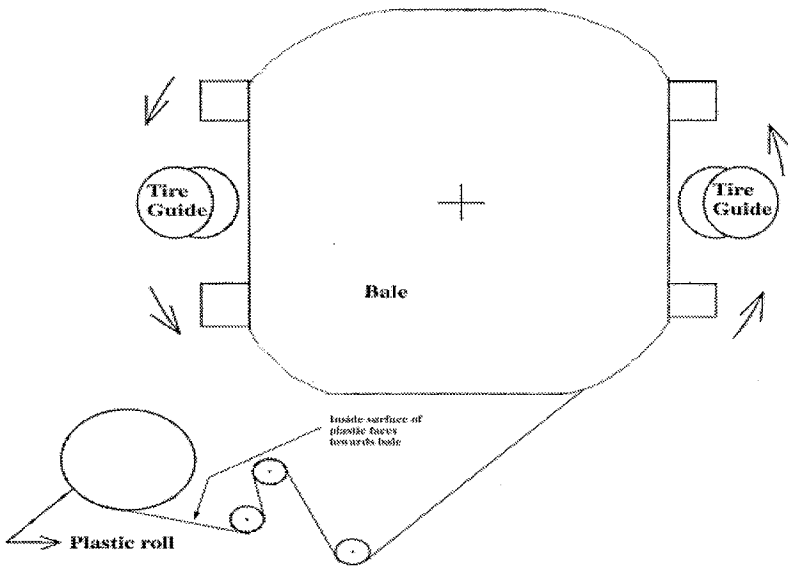

**PLASTIC DISPENSING DIAGRAM
SALSCO BALE WRAPPER**

Below is a quick reference chart for various "Flat Head Cap Screws" and the torque recommendations.

Bolt Size	Seating Torque Ft. - Lbs.	
	Coarse Thread	Fine Thread
1/4	8.3	9.2
5/16	16.7	18.3
3/8	29.2	33.3
7/16	46.7	52.1
1/2	70.8	83.3
5/8	141.7	158.3
3/4	250.0	266.7

- 1) To make closed center - Install #6 plug in Power Beyond Adaptor
- 2) To make open center - Remove Power Beyond Adaptor and insert #6 SAE plug in hole

**SAE-6
Steel or Metal**

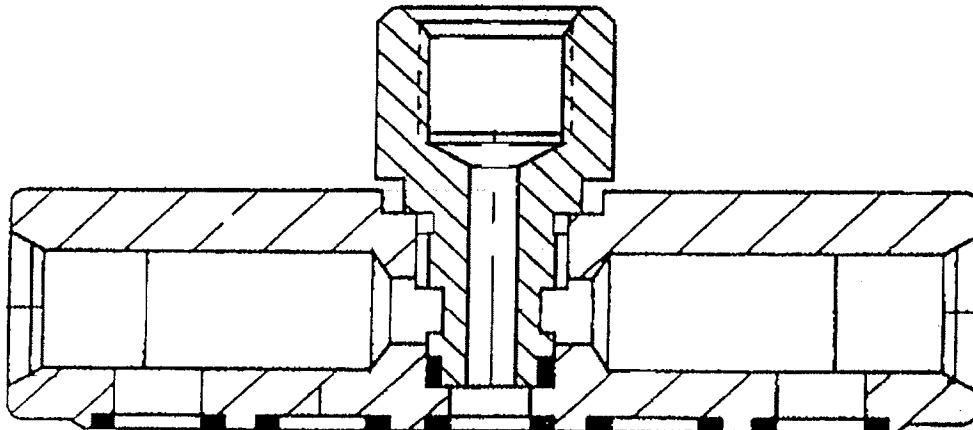

MV3 POWER BEYOND OUTLET

Please Note: Equipment shipped with #2 (open center position)

MAIN FRAME and TRANSPORT TIRE ASSEMBLY

Item #	Description	Part # & Qty.
1	COVER, ROTATING FRAME TOP	0471030 - 1
2	TUBE, ROLLER WELDMENT	0267064 - 2
3	BELT, CONTINUOUS	0304024 - 4
4	FRAME, ROTATING	0219075 - 1
5	ROLL & FRAME SUB-ASSY	0136059 - 1
6	CYLINDER, HYD.	0330033 - 1
7	FRAME, MAIN SUB-ASSY	0119053 - 1
8	PIN, SMALL WHEEL LOCK	0440037 - 2
9	AXLE, TRANSPORT WHEEL (RIGHT)	0202034 - 1
10	AXLE, TRANSPORT WHEEL (LEFT)	0202035 - 1
11	HUB, WHEELS TRANSPORT	0329002 - 2
12	WHEEL & RIM	0354020 - 2
17	HOUSING, PIVOT SUB-ASSY	0128108 - 1
18	NUT, LOCK	0338103 - 16
19	COVER, ROTATING FRAME BOTTOM	0471031 - 1
20	TUBE, PVC	0467063 - 16
21	BOLT, HEX HEAD	0346314 - 16
22	WASHER, FLAT	0353103 - 22

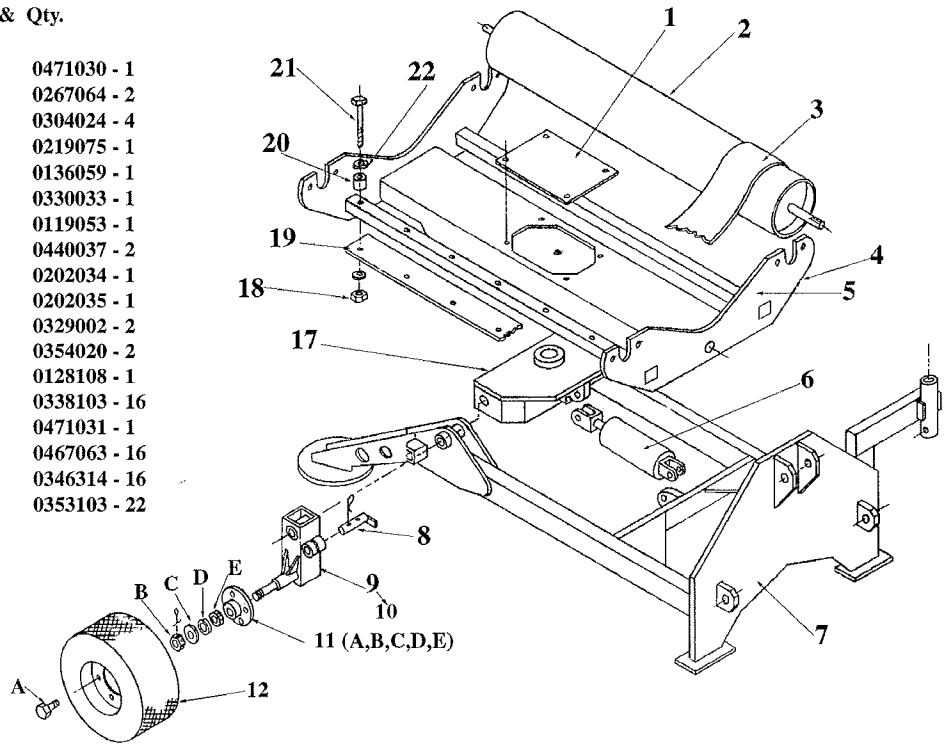

WHEEL BASE FRAME - LIFT ARM UNIT

Item #	Description	Part # & Qty.	Item #	Description	Part # & Qty.
1	CLAMP, STRAP	0410060 - 2	10	NUT, LOCKING	0338104 - 4
2	WEIGHTS, COUNTER, ARM (Option)	0465029 - 12	11	WASHER, FLAT	0353102 - 1
3	FRAME, LIFT ARM MTG.	0219073 - 1	12	SCREW	0346201 - 2
4	SPACER, WHEELS	0449060 - 4	13	SPRING, COMPRESSION	0350014 - 2
5	AXLE, LIFT ARM WHEELS	0202036 - 2	14	BRACKET, SPRING (RIGHT)	0206305 - 1
6	HUB, WHEELS (6-BOLT)	0329022 - 2	15	BRACKET, SPRING (LEFT)	0206304 - 1
7	HUB, WHEELS (5-BOLT)	0329023 - 2	16	CLAMP, STRAP	0410059 - 2
8	WHEEL & RIM (6-BOLT)	0354026 - 2	17	CLAMP, Wheel frame to Main frame	0210058 - 2
9	WHEEL & RIM (5-BOLT)	0354027 - 2			

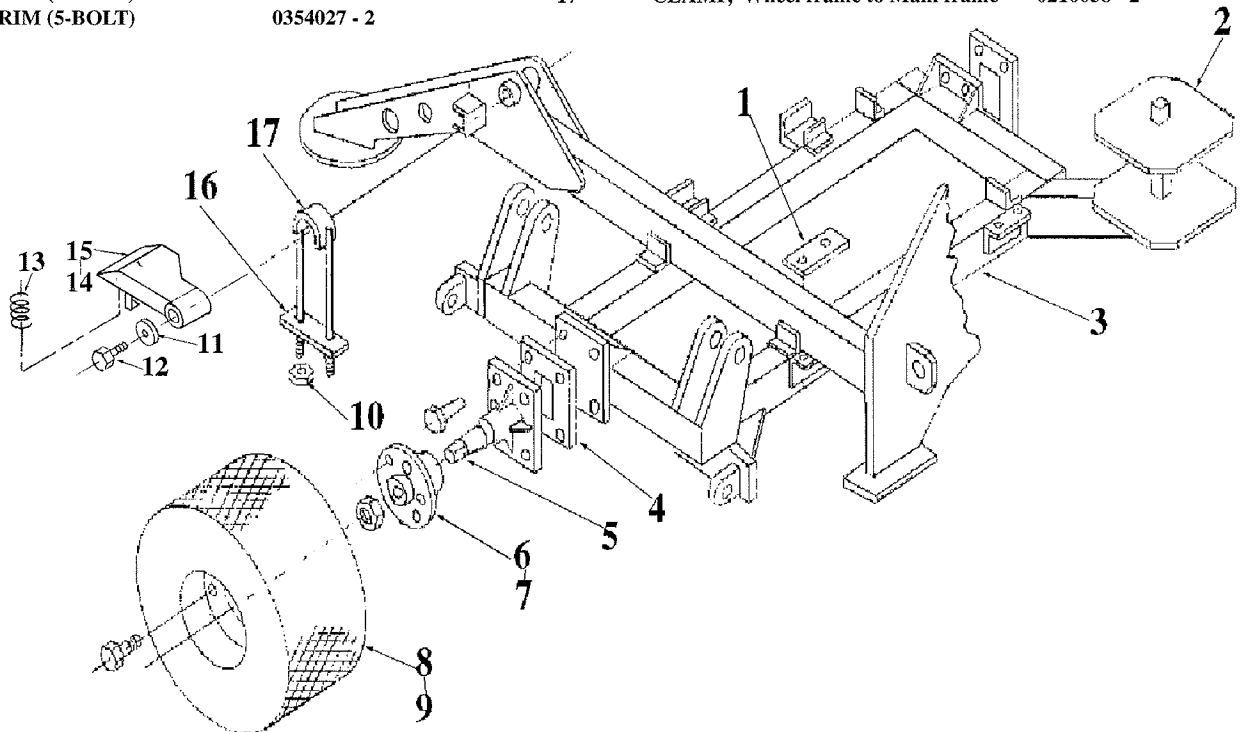

POWER PACK WITH BRACKET

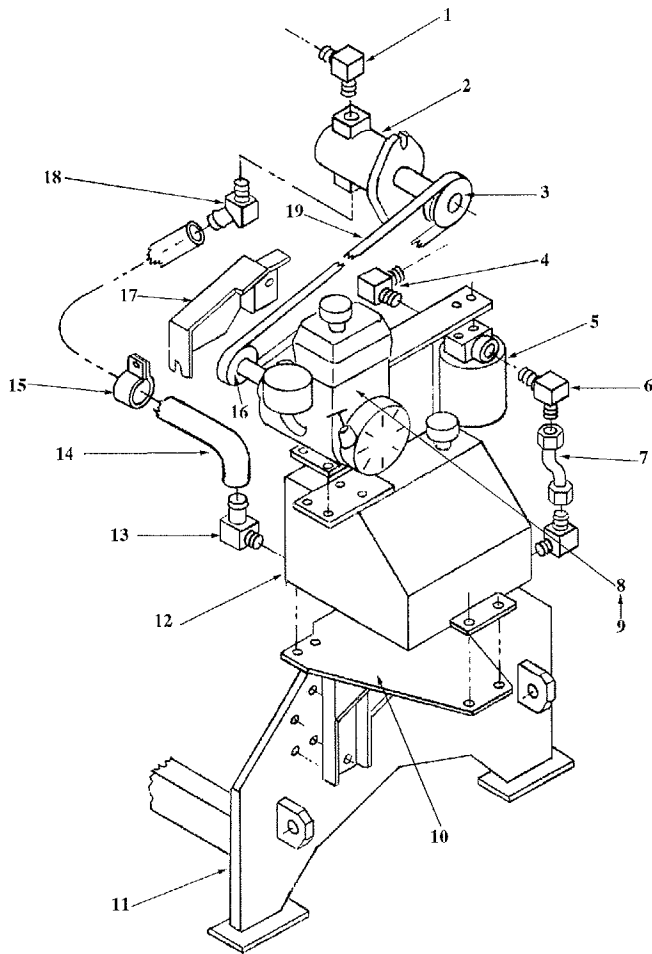

Item #	Description	Part # & Qty.
1	ADAPTER, 90°	0317079 - 1
2	PUMP, HYDRAULIC	0330027 - 1
3	PULLEY, PUMP	0342030 - 1
4	ADAPTER, 90°	0317040 - 1
5	FILTER, OIL	0318003 - 1
6	ADAPTER, 90°	0317061 - 2
7	HOSE, FILTER TO TANK 18"	0327035 - 1
8	MOTOR, 5 HP BRIGGS & STRATTON	0337011 - 1
9	MOTOR, 5.5 HP HONDA	0337040 - 1
10	BRACKET, POWER PACK MOUNT	0206120 - 1
11	FRAME, MAIN SUB-ASSY	0119053 - 1
12	TANK, POWER PACK	0152004 - 1
13	ADAPTER, 90°	0317081 - 1
14	HOSE, PUMP TO TANK 13"	0327050 - 1
15	CLAMP, HOSE	0310031 - 2
16	PULLEY, MOTOR	0342031 - 1
17	GUARD, REAR POWER PACK	0221099 - 1
18	ADAPTER, 45°	0317080 - 1
19	V-BELT	0304033 - 1

LIFT ARM ASSEMBLY

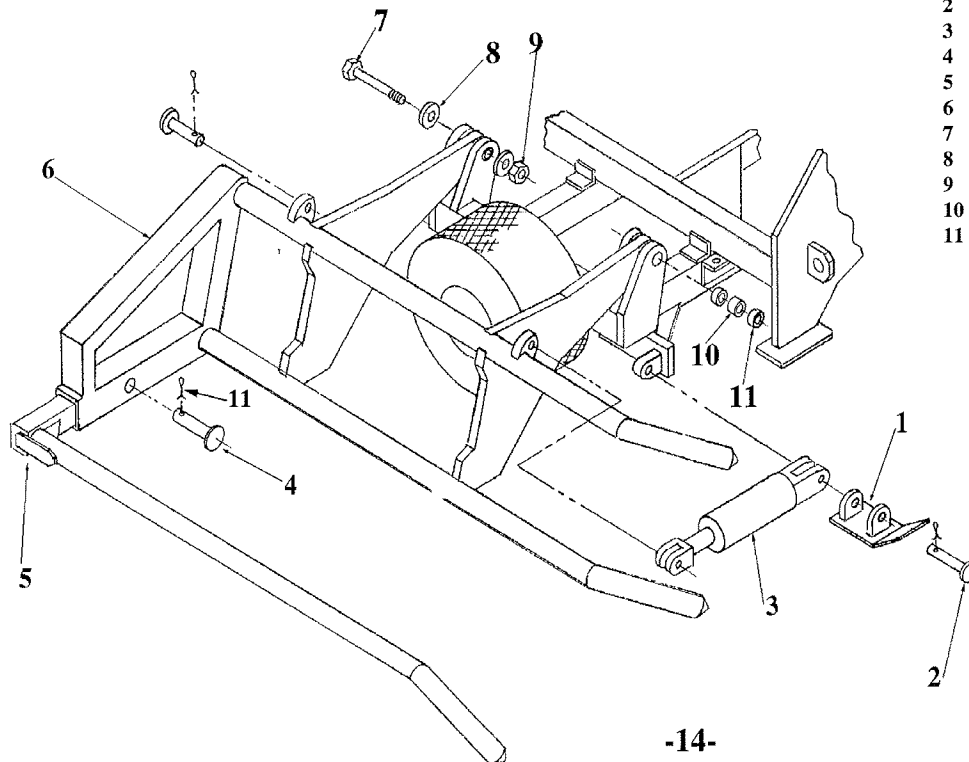

Item #	Description	Part # & Qty.
1	GUARD, HYD. CYL.	0221104 - 1
2	PIN, CYL. GUARD	0440038 - 1
3	CYLINDER, HYD.	0330032 - 2
4	PIN, POSITION LOCK	0440035 - 1
5	ARM, B.L. EXTENSION	0265037 - 1
6	ARM, BALE LIFT	0265036 - 1
7	BOLT	0346611 - 2
8	WASHER	0353109 - 4
9	NUT	0338106 - 2
10	BUSHING, LIFT ARM	0407016 - 2
11	ARM, B.L. EXTENSION	0265037 - 1

POWER PACK and HITCH ASSEMBLY

Item #	Description	Part # & QTY.	Item #	Description	Part # & Qty.
1	ADAPTER	0317040 - 1	10	BRACKET, JACK MOUNT	0369002 - 1
2	HOSE, HYD., 36"	0327033 - 1	11	HITCH, TONGUE	0225020 - 1
3	FILTER, OIL	0318003 - 1	12	JACK STAND	0369001 - 1
4	CAP, OIL TANK	0318004 - 1	13	TANK, POWER PACK	0152004 - 1
5	ADAPTER	0317061 - 1	14	PIN, HITCH BOTTOM	0440036 - 2
6	HOSE, HYD., 18"	0327035 - 1	15	MOTOR, 5.5 HP HONDA	0337040 - 1
7	GUARD, FRONT POWER PACK	0421103 - 1	16	MOTOR, 5 HP B & S	0337011 - 1
8	ADAPTER	0317021 - 1	17	PULLEY, MOTOR	0342031 - 1
9	HITCH, ASSEMBLY	0225008 - 1	18	GUARD, REAR. POWER PACK	0221099 - 1
			19	V-BELT	0304033 - 1
			20	ADAPTER	0317080 - 1
			21	CLAMP, HOSE	0310031 - 2
			22	HOSE, PLAIN, 13"	0327050 - 1
			23	HOSE, HYD., 42"	0327070 - 1
			24	ADAPTER	0317079 - 1
			25	PUMP, HYD.	0330027 - 1
			26	PULLEY, PUMP	0342030 - 1
			27	PIN, HITCH TOP	0440035 - 1

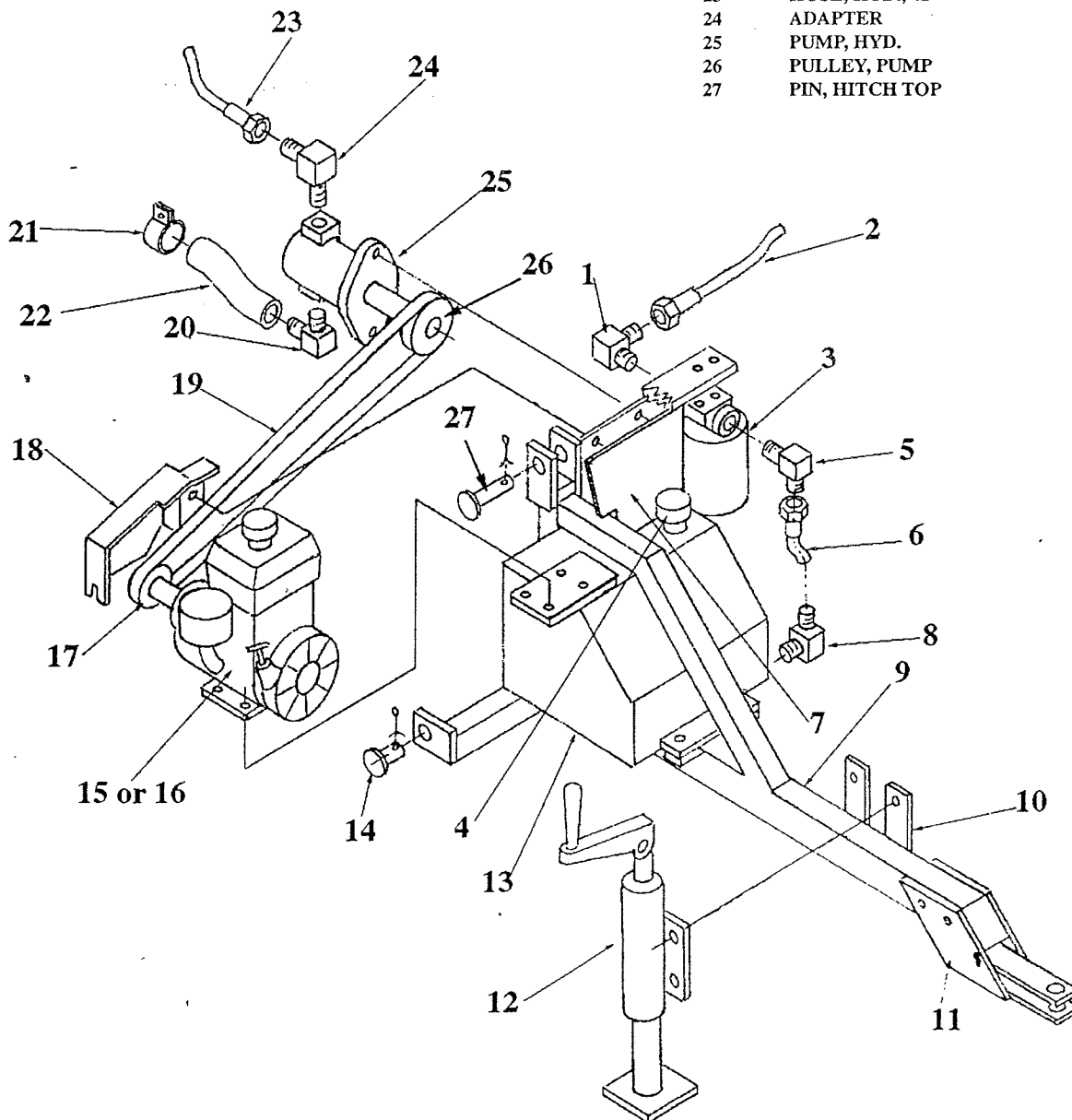

20" TENSIONER ASSEMBLY

Item #	Description	Part # & Qty.
1	ROD, PLASTIC PULL DOWN	0245017 - 1
2	TUBE, INNER	0467061 - 1
3	ARM, PLASTIC PULL DOWN	0265032 - 1
4	ARM, PLASTIC PULL DOWN SUPPORT	0265033 - 1
5	GUARD, HYD. CYL. PLASTIC PULL DOWN	0421105 - 1
6	HOLDER, HYD. CYL. PLASTIC PULL DOWN	0281002 - 1
7	COUNTER, RESET PANEL	0315051 - 2
8	BRKT., HYD. VALVE & COUNTER	0406360 - 1
9	ARM, PLASTIC DISPENSER WELDMENT	0265031 - 1
10	ARM, PLASTIC DISPENSER SUB-ASSY.	0165030 - 1
11	PIN, ARM LOCK	0440039 - 1
12	GUIDE, PLASTIC	0422020 - 3
13	HOLDER, PLASTIC ROLL	0181003 - 2
14	COLLAR, SET	0311007 - 1
15	CYLINDER, HYD. PULL DOWN	0330037 - 1
16	COLLAR, WELDMENT	0211030 - 1
17	TUBE, OUTER	0467062 - 1
18	HOSE, GUIDE COVER	0327023 - 3
19	SPROCKET	0351018 - 1
20	CHAIN, PLASTIC WRAP	0309017 - 1
21	SPROCKET, PLASTIC WRAP	0351002 - 2
22	NUT, LOCK	0338105 - 1
23	WASHER, FLAT	0358110 - 3
24	SPROCKET, IDLER	0351011 - 1
25	TUBING, 5/8 I.D. X 1 3/8	STOCK - 1
26	BOLT, CARRIAGE	0346053 - 1
27	GRIP, PLASTIC	0332014 - 1
28	HANDLE, COLLAR	0423039 - 1
29	BEARING, FLANGETTE	0303005 - 12
30	BEARING, INSERTS	0303023 - 6
31	COLLAR, SET	0311006 - 2
32	PIN, HITCH	0340006 - 3
33	PIN, ARM ROTATING LOCK	0440044 - 1

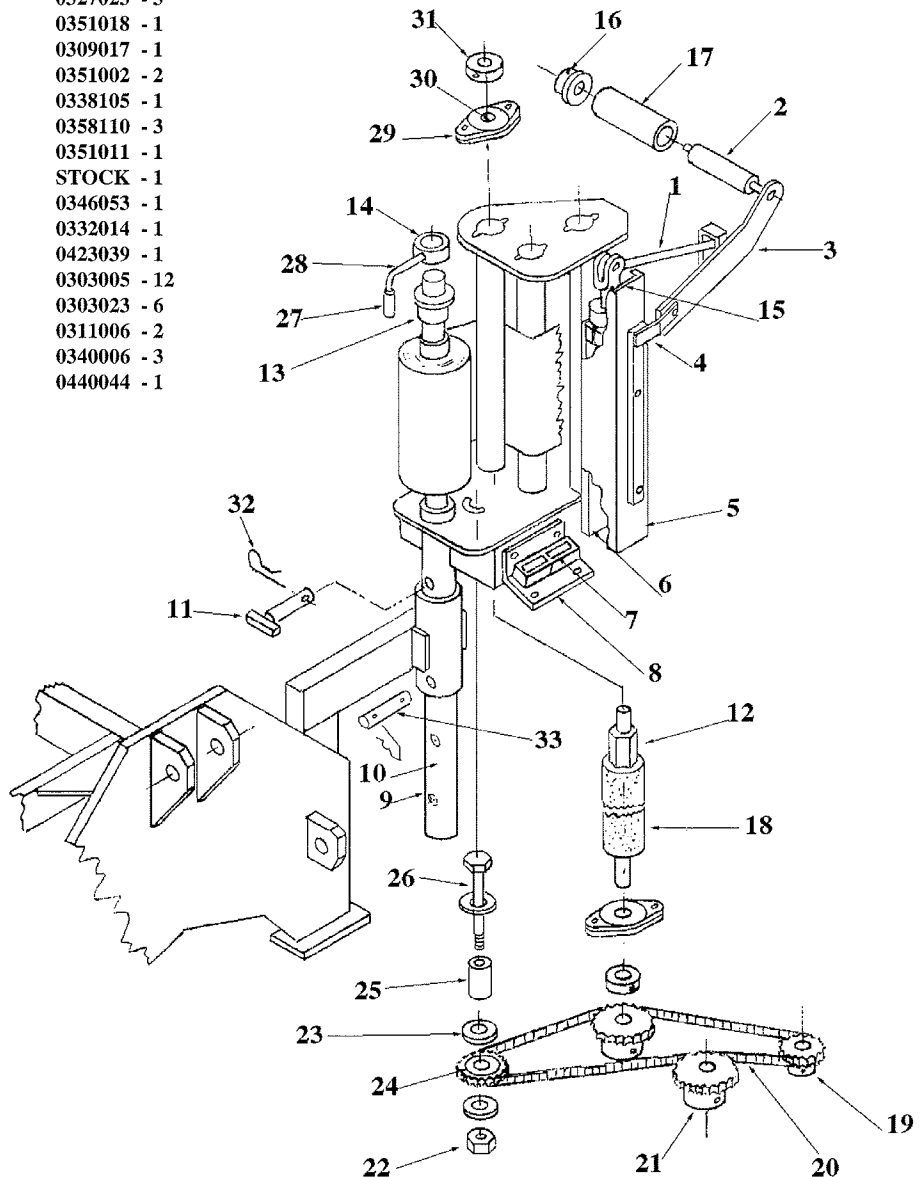

30" TENSIONER ASSEMBLY (OPTION)

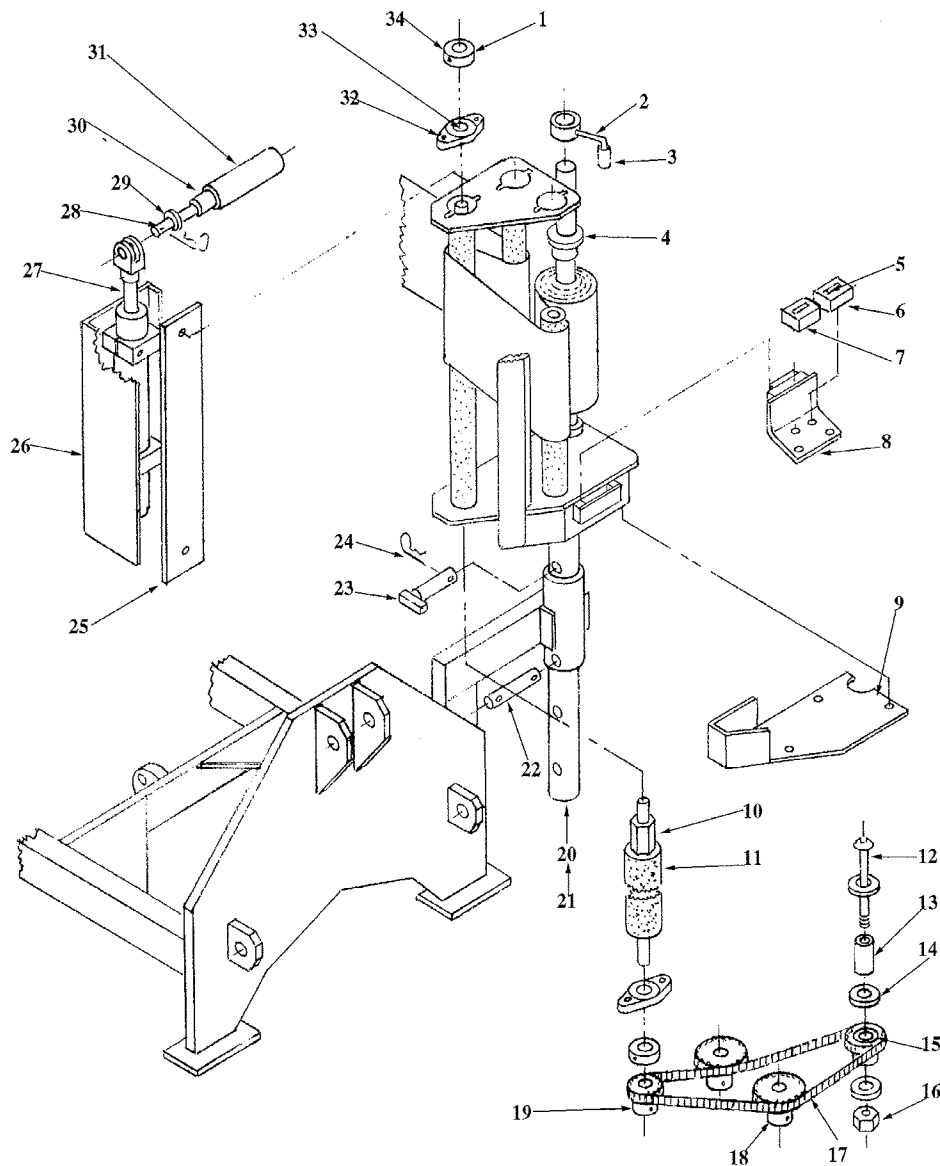

Item #	Description	Part # & Qty.	Item #	Description	Part # & Qty.
1	COLLAR, SET	0311007 - 1	17	CHAIN, PLASTIC WRAP	0309017 - 1
2	HANDLE, COLLAR	0423039 - 1	18	SPROCKET	0351002 - 2
3	GRIP, PLASTIC	0332014 - 1	19	SPROCKET	0351018 - 1
4	HOLDER, PLASTIC ROLL	0181003 - 2	20	ARM, PLASTIC DISPENSER (SUBASSEMBLY)	0165039 - 1
5	BOX, COUNTER	0280006 - 2	21	ARM, PLASTIC DISPENSER (WELDMENT)	0265040 - 1
6	COUNTER, WRAP	0315051 - 1	22	PIN - ARM ROTATE LOCK	0440044 - 1
7	COUNTER, DUMP	0315051 - 1	23	PIN, ARM LOCK	0440039 - 1
8	MOUNT, COUNTER BOX	0276103 - 1	24	PIN, HITCH	0340006 - 4
9	GUARD, PLASTIC DISPENSER	0221111 - 1	25	HOLDER, HYDRAULIC CYLINDER	0281002 - 1
10	GUIDE, PLASTIC ROLL	0422022 - 3	26	GUARD, HYDRAULIC CYLINDER	0421110 - 1
11	HOSE, GUIDE COVER	0327089 - 3	27	CYLINDER, HYDRAULIC PULL DOWN	0330037 - 1
12	BOLT, CARRIAGE	0346530 - 1	28	ROD, PLASTIC PULL DOWN	0245020 - 1
13	TUBING, 5/8" I.D. X 1 3/8"	STOCK	29	WASHER, FLAT	1/2" I.D. STOCK
14	WASHER, FLAT	0353110 - 3	30	TUBE, INNER	1/2" I.D. STOCK
15	SPROCKET, IDLER	0351011 - 1	31	TUBE, OUTER	0267073 - 1
16	NUT, LOCK	0338105 - 1	32	BEARING, FLANGETTE	0303005 - 12
			33	BEARING, INSERT	0303023 - 6
			34	COLLAR, SET	0311006 - 6

CUT & TIE ASSEMBLY BALE GUIDE & ASSEMBLY

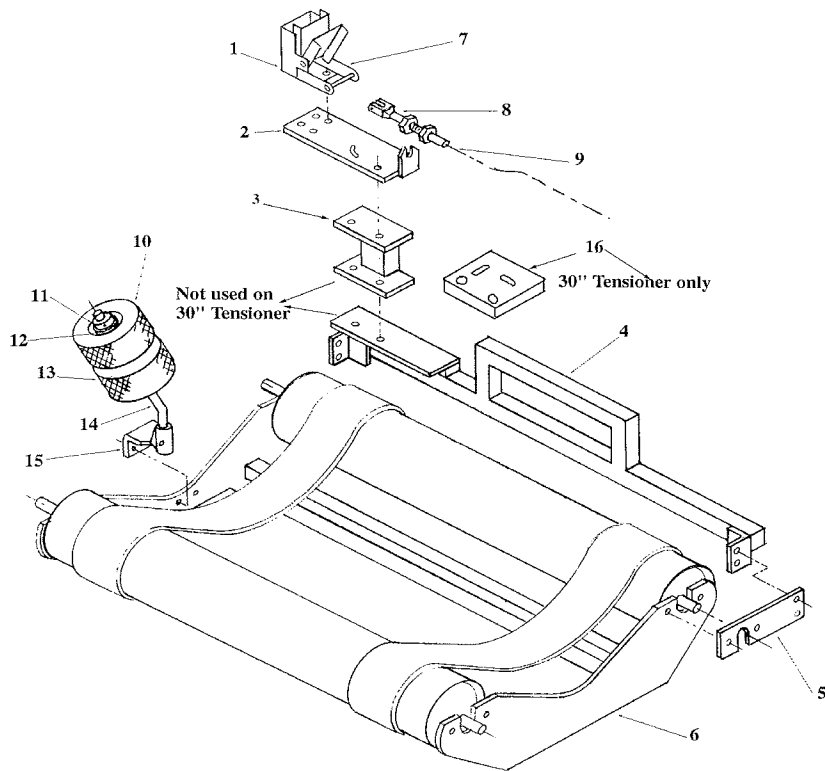

Item #	Description	Part # & Qty.
1	BASE, CUT & TIE ASSY.	0210050 - 1
2	MOUNT, CUT & TIE CLAMP	0219068 - 1
3	RISER BLOCK	0273002 - 1
4	FRAME, CUT & TIE, MNTG	0219068 - 1
5	PLATE, SUPPORT	0441558 - 2
6	ROLL & FRAME SUB-ASSY.	0136059 - 1
7	CLAMP, CUT & TIE SUB-ASSY	0110057 - 1
8	YOKE, ADJUSTER	0340002 - 2
9	CABLE, PUSH/PULL	0308022 - 1
10	WHEEL, BALE GUIDE	0354008 - 4
11	COLLAR, SET	0311006 - 4
12	WASHER, FLAT	0353106 - 4
13	WHEEL, BALE GUIDE SUB-ASSY.	0154034 - 2
14	SHAFT, GUIDE WHEEL	0448054 - 2
15	BRACKET, GUIDE WHEEL	0206199 - 2
16	SUPPORT, CUT & TIE MOUNT	0477021 - 1

CUT & TIE SUB-ASSEMBLY

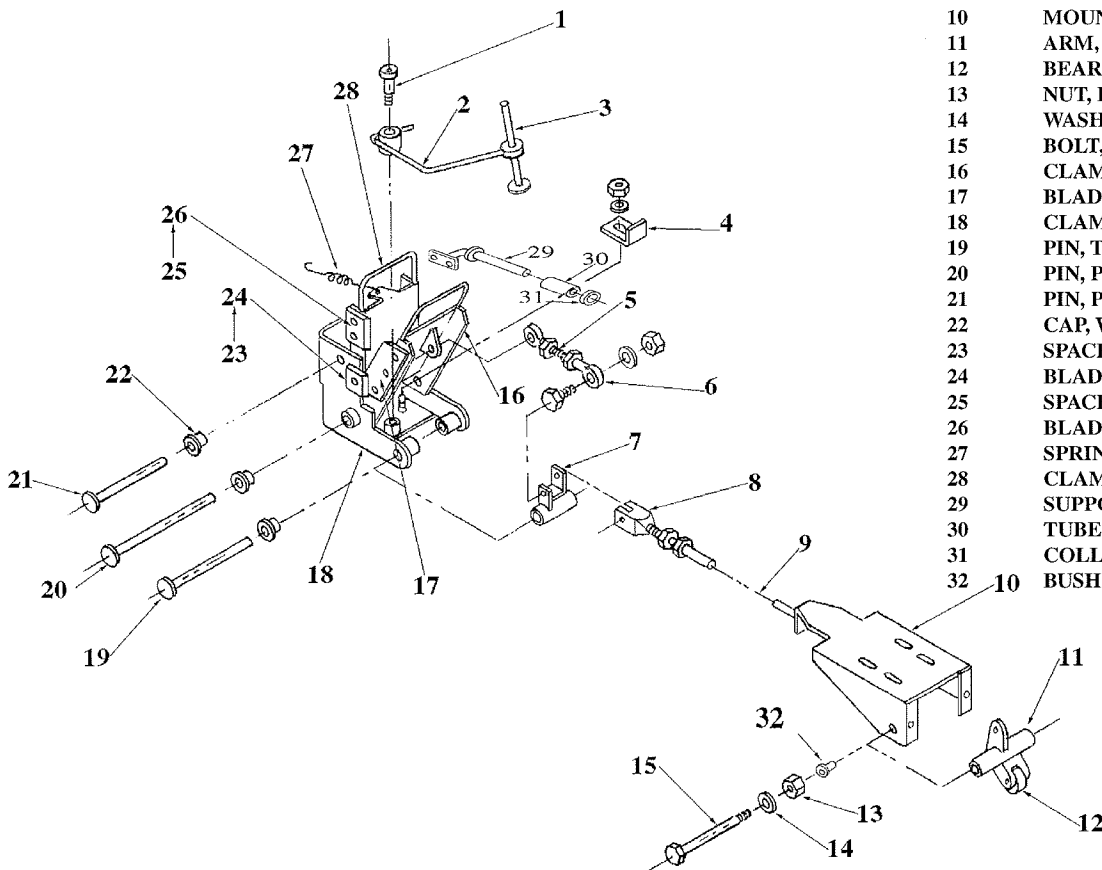

Item #	Description	Part # & Qty.
1	SCREW, SHOULDER	0346473 - 1
2	ROD, TRIP CUT & TIE	0245015 - 1
3	ROD, TRIP EXTENSION	0245018 - 1
4	ADJUSTER, TRIP	0401002 - 1
5	ROD, THREADED	0345019 - 1
6	BEARING, ROD ENDS	0303019 - 2
7	ARM, TRIP PIVOT	0265035 - 1
8	YOKE, ADJUSTER	0340002 - 2
9	CABLE, PUSH/PULL	0308022 - 1
10	MOUNT, TRIP CONTROL	0276096 - 1
11	ARM, TRIP BEARING	0265034 - 1
12	BEARING, BALL	0303036 - 1
13	NUT, LOCK	0338102 - 1
14	WASHER, FLAT	0353102 - 1
15	BOLT, HEX HEAD	0346219 - 1
16	CLAMP, LEFT	0210049 - 1
17	BLADE, RIGHT	0405016 - 1
18	CLAMP, BASE	0210050 - 1
19	PIN, TRIP	0240041 - 1
20	PIN, PIVOT RIGHT	0240042 - 1
21	PIN, PIVOT LEFT	0240043 - 1
22	CAP, WASHER/FASTENER	0371033 - 3
23	SPACER, BLADE	0449070 - 1
24	BLADE, LEFT BOTTOM	0405039 - 1
25	SPACER, BLADE	0449069 - 1
26	BLADE, LEFT TOP	0405038 - 1
27	SPRING, EXTENSION	0350020 - 4
28	CLAMP, RIGHT	0406266 - 1
29	SUPPORT, PLASTIC WRAP	0277020 - 1
30	TUBE	STOCK - 1
31	COLLAR, SET	0311031 - 1
32	BUSHING, BRONZE	0303020 - 2

ROLL & FRAME SUB-ASSEMBLY

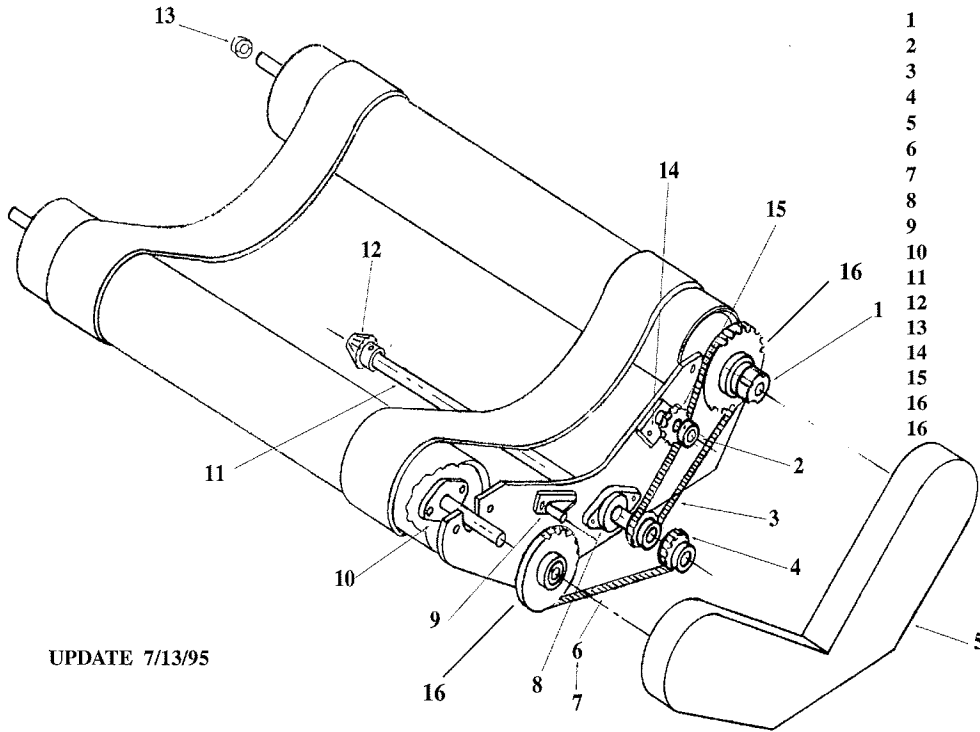

Item #	Description	Part # & Qty
1	BUSHING, TAPER LOCK	0351008 - 2
2	COLLAR, SPLIT	0311021 - 6
3	CHAIN, LEFT SIDE	0309020 - 1
4	SPROCKET	0351005 - 2
5	GUARD, CHAIN DRIVE	0221106 - 1
6	CHAIN, RIGHT SIDE	0309015 - 1
7	MASTER LINK	0309006 - 3
8	BEARING, FLANGE	0303006 - 2
9	BRACKET, CHAIN TENSION, RIGHT	0206310 - 1
10	BEARING, FLANGE	0303031 - 4
11	SHAFT, PINON	0448043 - 1
12	GEAR, BEVEL	0363002 - 1
13	COLLAR, SPLIT	0311020 - 4
14	BRACKET, CHAIN TENSION, LEFT	0206361 - 1
15	SPROCKET, IDLER	0351011 - 3
16	SPROCKET, DRIVE (20" TENSIONER)	0351032 - 2
16	SPROCKET, DRIVE (30" TENSIONER)	0351034 - 2

UPDATE 7/13/95

Item #	Description	Part # & Qty.
1	NUT, CASTLE	0338210 - 1
2	GEAR, BEVEL (ALTERED)	0451019 - 1
3	CHAIN, # 50	0309016 - 1
4	MASTER LINK, # 50	0309008 - 1
5	SHAFT, PIVOT	0448034 - 1
6	SPROCKET, (WELDED)	0251027 - 1
7	MOTOR, HYDRAULIC	0330024 - 1
8	TUBING, ALUMINUM	0340028 - 1
9	WIRE, CONDUCTOR	0315037 - 1
10	WIRE NUT	0315049 - 1
11	SCREW, FLAT HEAD	0346872 - 2
12	MERCURY BULB SWITCH	0315041 - 1
13	PROJECT CASE	0308017 - 1
14	MAGNETIC SWITCH	0315038 - 1
15	SHAFT, WHEELS	0448076 - 2
16	SHAFT, NO WHEELS	0448077 - 2
17	BUSHING, BRONZE	0307005 - 2
18	COLLAR, SET	0311007 - 2
19	PIN, LOCK	0440040 - 1
20	SPROCKET, (ALTERED)	0451028 - 1
21	BEARING, CONE	0303011 - 2

PIVOT HOUSING SUB-ASSEMBLY

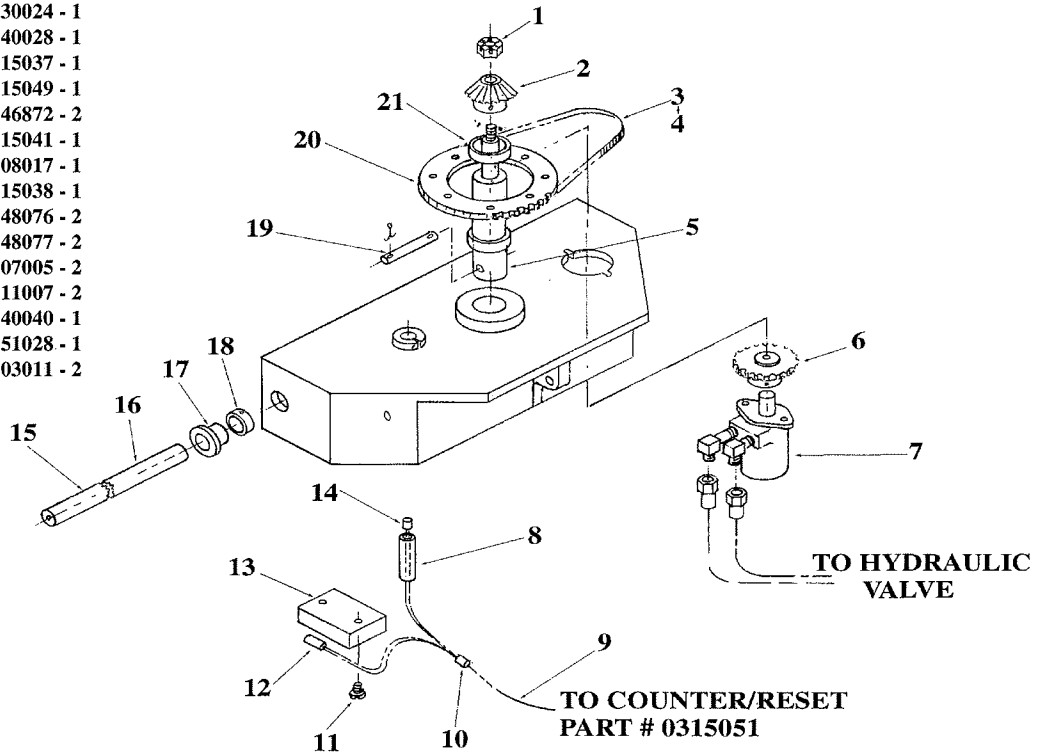

HYDRAULIC ASSEMBLY - 3 POINT HITCH

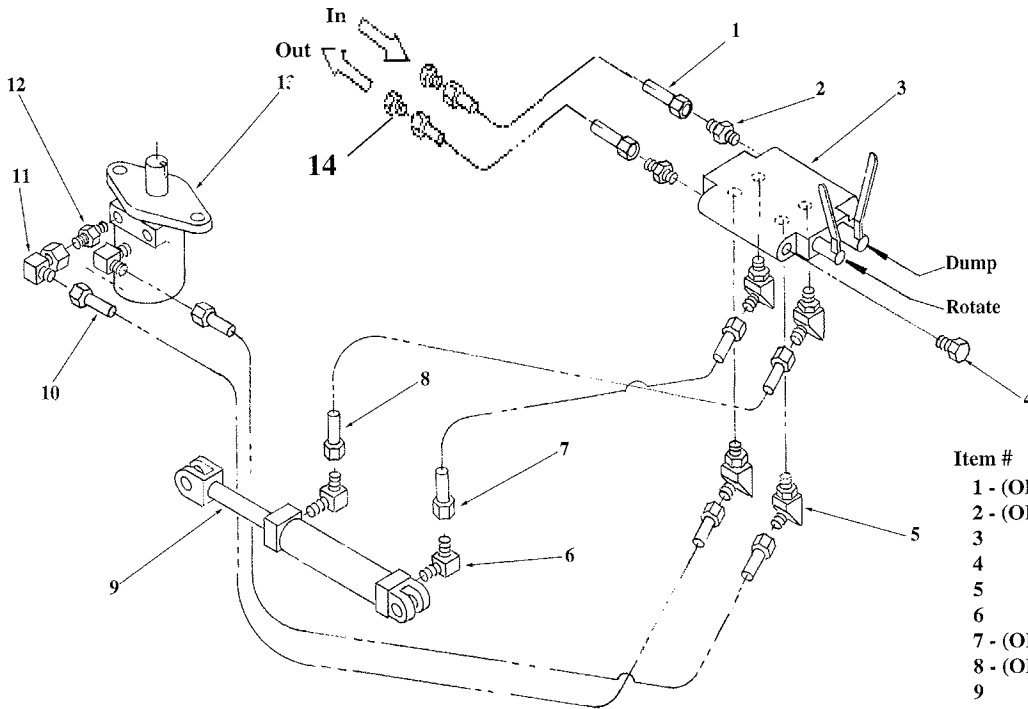

Item #	Description	Part # & Qty.
1 - (OPT)	HOSE, TO TRACTOR 60"	0327051 - 2
2 - (OPT)	ADAPTER	0317066 - 2
3	VALVE, HYDRAULIC	0330034 - 1
4	PLUG	0317093 - 2
5	ADAPTER	0317065 - 4
6	ADAPTER,	0317049 - 3
7 - (OPT)	HOSE, DUMP 64"	0327032 - 1
8 - (OPT)	HOSE, DUMP 76"	0327031 - 1
9	CYLINDER, HYDRAULIC	0330033 - 1
10- (OPT)	HOSE, ROTATE	0327030 - 2
11	ADAPTER	0317006 - 1
12	ADAPTER	0317050 - 1
13	MOTOR, HYDRAULIC	0330024 - 1
14- (OPT)	ADAPTER, BUSHING	0317082 - 2

HYDRAULIC ASSEMBLY - POWER PACK UNIT (Mounted on Bracket)

Item #	Description	Part # & Qty.
1	HOSE, FILTER TO VALVE 60"	0327087 - 1
2	HOSE, PUMP TO VALVE 60"	0327087 - 1
3	ADAPTER	0317066 - 2
4	VALVE, HYDRAULIC	0330034 - 1
5	PLUG	0317093 - 2
6	ADAPTER	0317061 - 2
7	ADAPTER	0317065 - 4
8	ADAPTER	0317079 - 1
9	HOSE, CYLINDER TO VALVE 64"	0327032 - 1
10	HOSE CYLINDER TO VALVE 76"	0327031 - 1
11	ADAPTER	0317049 - 3
12	CYLINDER, HYDRAULIC	0330033 - 1
13	HOSE, MOTOR TO VALVE 93"	0327030 - 2
14	ADAPTER	0317006 - 1
15	ADAPTER	0317050 - 1
16	MOTOR, HYDRAULIC	0330024 - 1

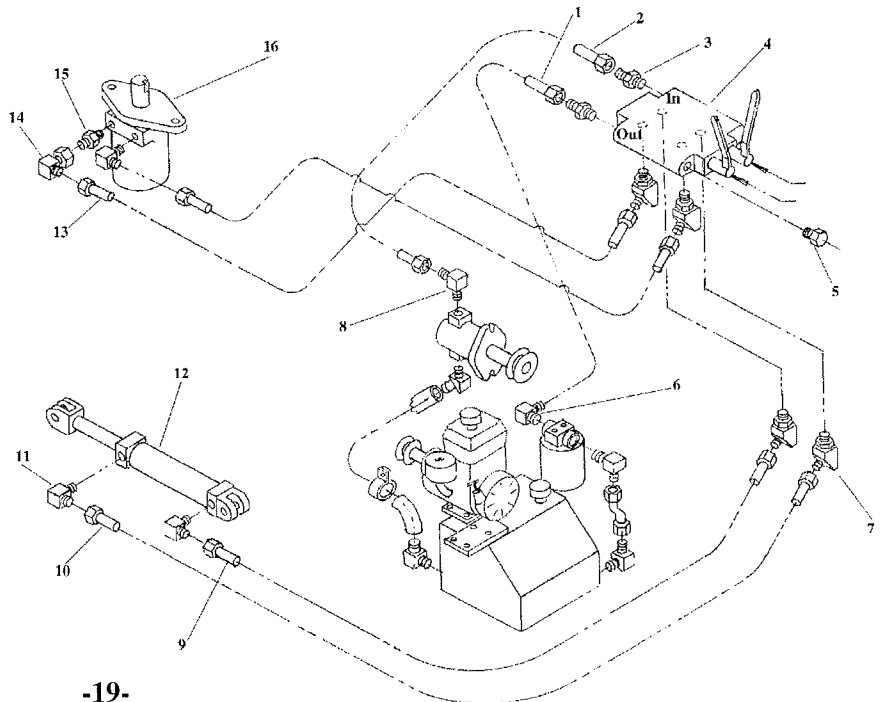

HYDRAULIC ASSEMBLY with POWER PACK AND LIFT ARM

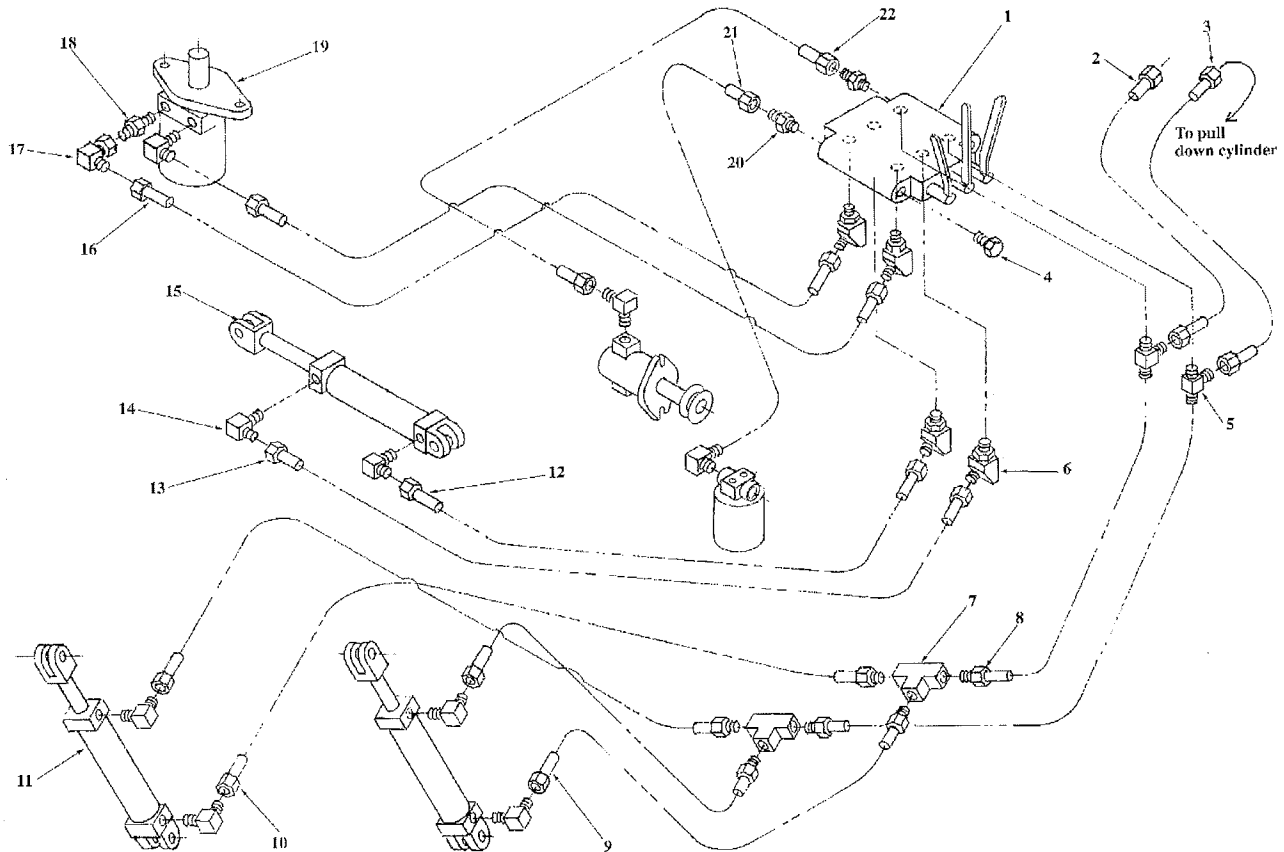

Item #	Description	Part # & Qty.
1	VALVE, HYDRAULIC - 3 SECTION	0330031 - 1
2	HOSE, CYLINDER (Pull Down) TO VALVE, 28"	0327074 - 1
3	HOSE, CYLINDER (Pull Down) TO VALVE 40"	0327075 - 1
4	PLUG	0317093 - 2
5	ADAPTER, RUNTEE	0317095 - 2
6	ADAPTER, 45°	0317065 - 4
7	ADAPTER, TEE	0317089 - 2
8	HOSE, TEE TO VALVE, 78"	0327092 - 2
9	HOSE, CYLINDER TO TEE, 34"	0327065 - 2
10	HOSE, CYLINDER TO TEE, 64"	0327064 - 2
11	CYLINDER, HYDRAULIC	0330032 - 2
12	HOSE, CYLINDER TO VALVE, 64"	0327032 - 1
13	HOSE, CYLINDER TO VALVE, 76"	0327031 - 1
14	ADAPTER, 90°	0317049 - 7
15	CYLINDER, HYDRAULIC	0330033 - 1
16	HOSE, MOTOR TO VALVE, 93"	0327030 - 2
17	ADAPTER, 90°	0317006 - 1
18	ADAPTER	0317050 - 1
19	MOTOR, HYDRAULIC	0330024 - 1
20	ADAPTER	0317066 - 2
21	HOSE, FILTER TO VALVE, 36"	0327033 - 1
22	HOSE, PUMP TO VALVE, 42"	0327070 - 1
23	CYLINDER, HYDRAULIC PULL DOWN	0330037 - 1
24	ADAPTER, 90°, MODIFIED	0317111 - 1
25	ADAPTER, 90°	0317046 - 1

Bolt Torque Info

Torque and Clamp loads for grade 5 and 8 fasteners.

Size	Grade 5			Grade 8		
	Clamps (lbs)	Torque (ft-lbs)		Clamps (lbs)	Torque (ft-lbs)	
		dry	oiled		dry	oiled
1/4-20	2000	8	6	2850	12	9
1/4-28	2300	10	7.5	3250	14	10
5/16-18	2250	17	13	4700	25	18
5/16-24	3700	19	14	5200	25	20
3/8-16	4950	30	23	7000	45	35
3/8-24	5600	35	25	7900	50	35
7/16-14	6800	50	35	9550	70	55
7/16-20	7600	55	40	10650	80	60
1/2-13	9000	75	55	12750	110	80
1/2-20	10250	90	65	14375	120	90
9/16-12	11600	110	80	16375	150	110
9/16-18	13000	120	90	18250	170	130
5/8-11	14400	150	110	20350	220	170
5/8-18	16375	180	130	23000	240	180
3/4-10	21300	260	200	30100	380	280
3/4-16	23800	300	220	33500	420	320

Drive Belt Tension Measurement by Deflection

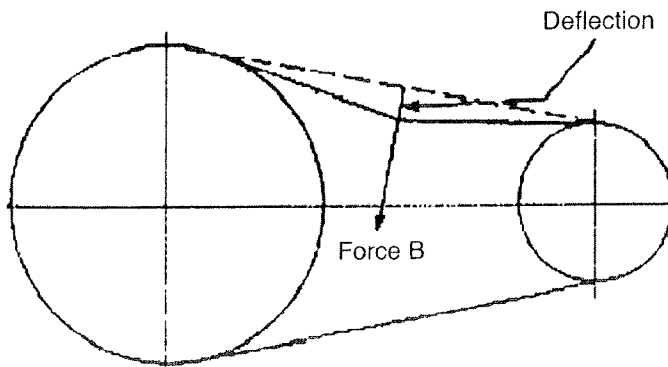

Deflection should be 3/8" when
8-12 lbs. push is applied at "B"

Suggested Tightening Torques For Alloy 1960 Inch Series Socket Head Cap Screws

NOMINAL SIZE	BASIC SCREW DIAMETER INCHES	TORQUE TO TIGHTEN SCREWS TO YIELD (in-lb)		TIGHTENING TORQUE* (in-lb)	
		UNRC	UNRF	UNRC	UNRF
0	0.0600	—	3.5	—	2.6
1	0.0730	6	6.5	4.5	4.8
2	0.0860	10	11	7.5	8
3	0.0990	15	16	11	12
4	0.1120	22	24	16	18
5	0.1250	32	33	24	24
6	0.1380	40	45	30	34
8	0.1640	74	78	55	58
10	0.1900	105	120	79	90
		(ft-lb)		(ft-lb)	
1/4	0.2500	22	25	17	19
5/16	0.3125	46	51	35	38
3/8	0.3750	83	93	62	70
7/16	0.4375	132	146	100	109
1/2	0.5000	203	230	150	172
5/8	0.6250	380	430	283	317
3/4	0.7500	667	750	500	562
7/8	0.8750	917	1020	688	767
1	1.0000	1390	1520	1040	1080
1-1/4	1.2500	2780	3080	2080	2310
1-1/2	1.5000	4850	5450	3625	4080

Nominal Sizes	Tensile Strength P.S.I. Min.	Yield Strength P.S.I. Min.	Elongation* In 2 Inches Per Cent Min.	Reduction of Area* Per Cent Min.	Minimum Hardness Rockwell C
0 to 1/2	180,000	162,000	12	35	39
Over 1/2	170,000	153,000	14	40	38

* Listed tightening torques are 75 percent of the torque to yield based on ASTM574. Specification listing tensile strength of 180,000 PSI for screw size 0.500 and smaller and 170,000 PSI for screw size 0.625 and larger. Values based on plated and non-lubricated fasteners.

Tightening torques are only recommended for proper applications. Refer to your engineering stats.

Suggested Tightening Torques For Other Alloy Socket Screw Products (INCH-POUND)

Nom. size	Basic Screw Diameter	Button Head Flat Head Hex Key Size	Flat Head		Button Head		Nominal Size	Hex Key Size	Shoulder Screw	Low Head
			Tightening Torque	Tightening Torque	Tightening Torque	Tightening Torque				
0	.060	.035	—	1.5	—	1.5	—	—	—	—
1	.073	.050	2.5	2.5	2.5	2.5	—	—	—	—
2	.086	.050	4.5	4.5	4.5	4.5	—	—	—	—
3	.099	1/16	7	7	7	7	—	—	—	—
4	.112	1/16	8	8	8	9	4	.050	—	5.0
5	.125	5/64	12	13	12	12	5	.062	—	9.5
6	.138	5/64	15	17	16	16	6	.062	—	9.5
8	.164	3/32	30	31	30	30	8	5/64	—	19.4
10	.190	1/8	40	45	40	45	10	3/32	—	33.5
1/4	.250	5/32	100	110	100	110	1/4	1/8	50	77.9
5/16	.312	3/16	200	220	200	220	5/16	5/32	125	156.0
3/8	.375	7/32	350	400	350	400	3/8	3/16	265	273.0
7/16	.437	1/4	560	625	—	—	7/16	7/32	—	428.0
1/2	.500	5/16	850	1,000	850	1,000	1/2	1/4	470	615.0
9/16	.562	5/16	1,200	1,360	—	—	—	—	—	—
5/8	.625	3/8	1,700	1,900	1,700	1,800	5/8	5/16	1,150	1,315.0
3/4	.750	1/2	3,000	3,200	—	—	3/4	3/8	2,000	—
7/8	.875	9/16	5,000	5,400	—	—	—	—	—	—
1	1.000	5/8	8,000	7,600	—	—	1	1/2	4,000	—

* Listed tightening torques are 75 percent of the torque to yield based on ASTM574. Specification listing tensile strength of 180,000 PSI for screw size 0.500 and smaller and 170,000 PSI for screw size 0.625 and larger. Values based on plated and non-lubricated fasteners.

Tightening torques are only recommended for proper applications. Refer to your engineering stats.

WARRANTY POLICY

Your Salsco commercial or turf equipment product is a commercial type product and is normally manufactured and sold for commercial or industrial use. Salsco, will, for the original purchaser, for one (1) year from the date of purchase (90 days if used for rental purposes) repair, replace, free of charge, any part or parts found to be defective in material, workmanship or both. Any transportation charges to be borne by the purchaser.

If during the warranty period, the product does not function properly due to defect, simply contact Salsco and follow the warranty procedures listed below.

This warranty does not include incidental or consequential damages and is exclusive of any implied warranties. This warranty does not include normal maintenance parts, including, but not limited to spark plugs, filters, lubricants, etc.

This warranty does not include parts or components which are covered under the original manufacturers warranty, including, but not limited to engine and differential.

SALSCO WARRANTY PROCEDURE

In order for Salsco to process your warranty claims in a timely manner, you must follow the simple procedures listed below

- 1) **MACHINE OR PART FAILURE**
 - A) Call our service department for easy instructions on how to correct or repair the problem. Preventive maintenance will also be suggested
 - B) Fill in all information requested on warranty claim form.
 - C) List all parts used. Make sure part numbers are correct. You can obtain these from your manual. Any parts that you believe to be defective or any parts that break should be retained for possible inspection until after the warranty has been paid or parts have been replaced.
 - D) Should Salsco want to have parts returned to the factory, you will be given a return authorization number, which must be written on the outside of the package and on the enclosed paperwork. Transportation charges are to be borne by the purchaser. Salsco will not accept freight collect shipments.

CALL SALSCO'S SERVICE DEPARTMENT OR YOUR SERVICING DEALER BEFORE YOU TRY TO FIX ANY PROBLEM

WARRANTY CLAIM

IMPORTANT

NOTE: ALL OF THE INFORMATION REQUESTED IS REQUIRED TO PROCESS YOUR WARRANTY CLAIM. FAILURE TO PROVIDE ALL THIS INFORMATION WILL DELAY THE PROCESS CONSIDERABLY.

SALSCO, INC.
105 School House Rd.
Cheshire, CT 06410
203/271-1682, 1/800/872-5726
203/271-2596 (fax)

DATE MAILED: _____
DATE RECEIVED: _____

Owner _____ Phone # (____) _____
Address _____
Purchased From: _____ Phone # (____) _____
Address: _____
Date Purchased: _____ Invoice # _____ Date Failed: _____ Hrs. Used _____
Model # _____ Serial # _____

Probable cause of failure or problem: (word defective not sufficient)

Work performed/Comments on repair: _____

Labor hours requested: _____ Shop labor rate: _____ Effective date: _____
Warranty requested for the following parts: Return Auth # _____ (If applicable)

Part #	Description	Qty	Price Each	Invoice #

Preventive maintenance suggested and by whom: _____

FOR OFFICE USE ONLY

Dealer Delivery Report Rec. _____ Warranty Card Rec. _____ War. Claim # _____
Date Apr. _____ Parts Total: _____ Labor Total: _____ Apr. by _____
Date Rejected _____ Rejected by _____ Reason for Rejection _____

REVISED - 9/1/94

Salsco, Inc.

105 School House Rd.
Cheshire, CT 06410
203-271-1682

DEALER DELIVERY REPORT

			SERIAL NO.			
DEALER		CITY	STATE		ZIP	
PURCHASER (Last Name or Company)	(First Name)	(Middle Name)	ADDRESS	CITY	STATE	ZIP

The undersigned dealer warrants that the above-described machine was carefully inspected, adjusted and prepared for delivery before delivery to the purchaser; that both the operation and maintenance of the machine were explained to the purchaser, and that a copy of the Owner's Instruction Manual were given to the purchaser and his attention called to Our Warranty and any operating instructions included in the manual and caution notes.

The undersigned purchaser certifies that the operation and maintenance of the above-described machine have been explained to him; acknowledges receipt of a copy of the Owner's Instruction Manual and Our Warranty Policy printed in said Instruction Manual and Caution Notes. I also understand that it is my responsibility to explain and make Salsco manuals available to new operators.

Date _____ Dealer _____

Date _____ Purchaser _____

Sign By _____

Sign By _____

Phone _____

Phone _____

FACTORY COPY WHITE - DEALER'S COPY YELLOW - OWNER'S COPY PINK

FORM NO. 8204

MODEL - _____ SERIAL NO. _____

SALSCO LIMITED WARRANTY CARD

1. DATE PURCHASED: _____
2. PURCHASER: _____
3. PURCHASER ADDRESS: _____
4. DEALER _____
5. DEALER ADDRESS: _____
6. WILL THIS EQUIPMENT BE USED COMMERCIALY? YES NO
7. DID DEALER SERVICE THIS EQUIPMENT AND INSTRUCT YOU IN ITS CARE AND SAFE OPERATION? YES NO
8. DID YOU RECEIVE AN "OPERATION & SERVICE MANUAL" AND SAFETY PAMPHLET? YES NO

NOTICE

SIGNED _____ Purchaser

IMPORTANT: THIS CARD MUST BE FILLED OUT COMPLETELY AND MAILED TO THE FACTORY WITHIN 10 DAYS OF PURCHASE DATE, OR YOUR LIMITED WARRANTY WILL BE VOIDED.

WHITE—DEALER YELLOW—OWNER CARD—FACTORY

